

# CFR 47 FCC Part 15.231

## TEST REPORT

Product : **Transmitter**

Trade Name : N/A

Model Number : #1411

FCC ID : ELVNTNH

Prepared for

### **Nutek Corporation**

NO. 167, Lane 235, Bauchiau Rd., Xindian District,  
New Taipei City 23145, Taiwan

TEL. : +886 2 2918 9478

FAX. : +886 2 2917 9069

Prepared by

### **Interocean EMC Technology Corp.**

No. 5-2, Lin 1, Tin-Fu, Lin-Kou Dist., New Taipei City,  
Taiwan 244, R.O.C.

TEL.: +886 2 2600 6861

FAX.: +886 2 2600 6859

#### **Remark:**

The test report consists of **28** pages in total. It shall not be reproduced except in full, without the written approval of IETC. This document may be altered or revised by IETC only, and shall be noted in the revision section of the document.

The test result in the report is only subjected to the test sample.

# Statement of Compliance

**Applicant:** Nutek Corporation

**Manufacturer:** Nutek Corporation

**Product:** Transmitter

**Model No.:** #1411

**Tested Power Supply:** 6Vdc Battery

**Date of Final Test:** Jul. 22, 2014

**Configuration of Measurements and Standards Used :**

FCC Rules and Regulations Part 15 Subpart C

1. The result of the testing report relate only to the item tested.
2. The testing report shall not be reproduced expect in full, without the written approval of IETC.

Report Issued: 2014/07/31

Project Engineer: 

Elli Chang

Approved: 

Jerry Liu

# Table of Contents

<b>1</b>	<b>Summary of Measurement</b>	<b>4</b>
<b>2</b>	<b>General Information</b>	<b>5</b>
2.1	Description of Equipment Under Test	5
2.2	Details of Tested Peripheral Equipment	6
2.3	Test Facility	7
<b>3</b>	<b>Test Specifications</b>	<b>8</b>
3.1	Test Standard	8
3.2	Operation Mode	8
3.3	Test Step of EUT	8
3.4	Test Equipment	9
<b>4</b>	<b>Radiated Emission Test</b>	<b>10</b>
4.1	Limits	10
4.2	Calculation of Average Factor	11
4.3	Configuration of Measurement	16
4.4	Test Procedure	16
4.5	Test Result	16
<b>5</b>	<b>Emission Bandwidth</b>	<b>20</b>
5.1	Limits	20
5.2	Test Result	20
<b>6</b>	<b>Photographs of Test</b>	<b>22</b>
6.1	Radiated Emission Measurement	22
<b>7</b>	<b>Photographs of EUT</b>	<b>24</b>

## 1 Summary of Measurement

<b>Report Clause</b>	<b>Test Parameter</b>	<b>Reference Document CFR47 Part15</b>	<b>Results</b>
4	Timing requirement	§15.231(a)	Pass
4	Radiated Emission	§15.231(b), 15.209	Pass
5	Emission Bandwidth	§15.231(c)	Pass

## 2 General Information

### 2.1 Description of Equipment Under Test

- Product** : Transmitter
- Model Number** : #1411
- Applicant** : **Nutek Corporation**  
NO. 167, Lane 235, Bauchiau Rd., Xindian District,  
New Taipei City 23145, Taiwan
- Manufacturer** : **Nutek Corporation**  
NO. 167, Lane 235, Bauchiau Rd., Xindian District,  
New Taipei City 23145, Taiwan
- Power Supply** : 6Vdc Battery
- Operating Frequency** : 433.92MHz
- Type of Modulation** : ASK
- Antenna Description** : This device uses PCB Printed antenna.  
The antenna is integral to the device, thereby meeting the  
requirement of FCC 15.203.
- Date of Test** : Jul. 01 ~ 22, 2014
- Additional Description** : 1) The Model Number “#1411” is representative selected in the  
test and included in this report.  
2) For more detail specification about EUT, please refer to the  
user’s manual.

## **2.2 Details of Tested Peripheral Equipment**

N/A

## 2.3 Test Facility

- Site Description** : ☒OATS 1
- Name of Firm** : Interocean EMC Technology Corp.
- Company web** : <http://www.ietc.com.tw>
- Location** : No. 5-2, Lin 1, Tin-Fu, Lin-Kou Dist., New Taipei City, Taiwan 244, R.O.C.
- Site Filing** :
- Federal Communication Commissions – USA  
Registration No.: 96399 (OATS 1, 2, 3 & Chamber 3)  
Designation No.: TW1020
  - Industry Canada (IC)  
OUR FILE: 46405-4437  
Registration No. (OATS 1): Site# 4437A-1  
Registration No. (OATS 3): Site# 4437A-3  
Registration No. (Chamber 3): Site# 4437A-5  
Registration No. (OATS 5): Site# 4437A-6
  - Voluntary Control Council for Interference by Information Technology Equipment (VCCI) – Japan  
Member No.: 1349  
Registration No. (Conducted Room): C-1094  
Registration No. (Conducted Room): T-1562  
Registration No. (OATS 1): R-1040; G-274  
Registration No. (OATS 2): R-1041
- Site Accreditation** :
- Bureau of Standards and Metrology and Inspection (BSMI) – Taiwan, R.O.C.  
Accreditation No.:  
SL2-IN-E-0026 for CNS13438 / CISPR 22  
SL2-IN-E-0026 for CNS14757-2 / IEC 62040-2  
SL2-R1-E-0026 for CNS13439 / CISPR 13  
SL2-R2-E-0026 for CNS13439 / CISPR 13  
SL2-A1-E-0026 for CNS13783-1 / CISPR 14-1  
SL2-L1-E-0026 for CNS 14115 / CISPR 15
  - Taiwan Accreditation Foundation (TAF)  
Accreditation No.: 1113
  - Vehicle Safety Certification Center (VSCC)  
Approval No.: TW16-11-0
  - TÜV NORD  
Certificate No: TNTW0801R-04
  - Nemko  
Authorisation No: AeLA 011  
Authorisation No: ELA 181

### 3 Test Specifications

#### 3.1 Test Standard

The EUT was performed according to FCC Part 15 Subpart C Section 15.231 procedure and setup followed by ANSI C63.4, 2003 requirements.

#### 3.2 Operation Mode

By preliminary testing and verifying three axis (X, Y and Z) position of EUT transmitted status, it was found that "X axis" position was the worst, then the final test was executed the worst condition and test data were recorded in this report

The EUT was operated in continuous transmission mode during all of the tests.



**X axis mode**



**Y axis mode**



**Z axis mode**

#### 3.3 Test Step of EUT

- 3.3.1 Setup the fixture to EUT for power supplying.
- 3.3.2 Turn on the power of all equipment.
- 3.3.3 Let the EUT continuous transmission. Executed the test.



### 3.4 Test Equipment

Instrument	Manufacturer	Model	Serial No.	Next Cal. Date
Spectrum Analyzer	R&S	FSP40	100478	2015/06/02
Preamplifier	Agilent	8449B	3008A01434	2015/05/07
Preamplifier	Agilent	83050A	3950A00225	2014/09/08
Horn Antenna	Schwarzbeck	BBHA 9120	9120D-583	2015/05/13
Horn Antenna	Schwarzbeck	BBHA 9170	213	2014/07/24
Cable	HARBOUR	27478LL142	CBL22	2015/01/01
EMI Test Receiver	Rohde & Schwarz	ESVS10	826148/011	2014/11/04
Biconical Antenna	Schwarzbeck	BBA 9106	VHA 9103-2418	2015/01/18
Log Antenna	Schwarzbeck	UHALP 9108 A	0738	2015/01/18
Pre-Amplifier	Agilent	8447D	2944A09703	2015/04/29
RF Cable	EMCI	EMC8D-NM-NM-25000	140105	2015/02/16
RF Cable	Mini-Circuits	CBL-3FL-NMNM	CBL56	2014/08/30
RF Cable	Insulated Wire	CBL59	CBL59	2015/01/22

Note: The above equipments are within the valid calibration period.

## 4 Radiated Emission Test

### 4.1 Limits

According to FCC 15.231(b) requirement:

In addition to the provisions of §15.205, the field strength of emissions from intentional radiator operated under this section shall not exceed the following:

#### Fundamental and Harmonics Emission Limits

Frequency (MHz)	Field Strength of Fundamental		Field Strength of Harmonics	
	( $\mu$ V/m@3m)	(dB $\mu$ V/m@3m)	( $\mu$ V/m@3m)	(dB $\mu$ V/m@3m)
433.92	10996	80.8	1099.6	60.8

#### General Radiated Emission Limit

Spurious Emission tested through until 10<sup>th</sup> harmonic. Radiated emissions, which fall in the restricted bands, as defined in §15.205 (a), comply with the radiated emission limits specified in §15.209 (a).

Frequency (MHz)	15.209 Limits	
	( $\mu$ V/m@3m)	(dB $\mu$ V/m@3m)
30-88	100	40
88-216	150	43.5
216-960	200	46
Above 960	500	54

Remark :

1. The table above tighter limit applies at the band edges.
2. The measurement distance in meters, which that between form closest point of EUT to instrument antenna.

## 4.2 Calculation of Average Factor

The output field strengths of specification in accordance with the FCC rules specify measurements with an average detector. During the test, a spectrum analyzer incorporating a peak detector was used. Therefore, a reduction factor can be applied to the resultant peak signal level and compared to the limit for measurement instrumentation incorporating an average detector.

The duty cycle is measured in 100 ms or the repetition cycle period, whichever is a shorter time frame. The duty cycle is measured by placing the spectrum analyzer to set zero span at 100kHz resolution bandwidth.

Averaging factor in dB =  $20 \log (\text{duty cycle})$

The duration of one cycle = 105.2ms

The duty cycle is simply the on-time divided by 100ms

Duty Cycle =  $(0.78\text{ms} \times 45 + 0.4\text{ms} \times 33) = 48.3 \text{ ms} / 100\text{ms}$

Therefore, the averaging factor is found by  $20 \log 0.483 = -6.32 \text{ dB}$

Please see the diagrams below.

# Duty Cycle

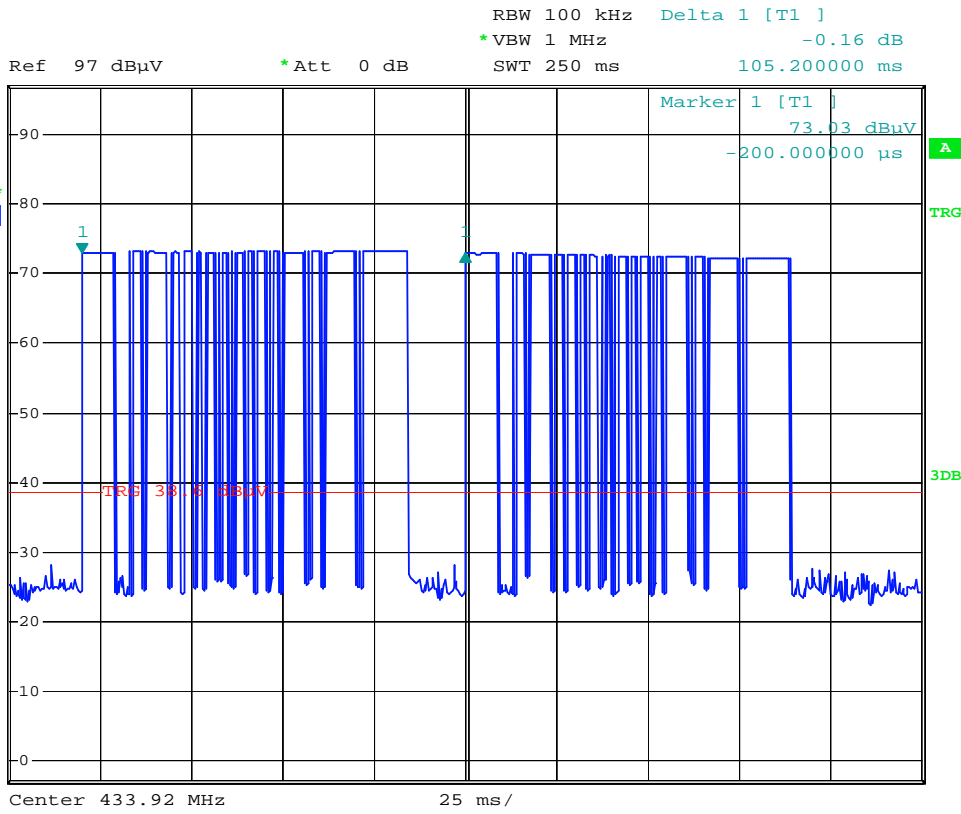

### Time Slot

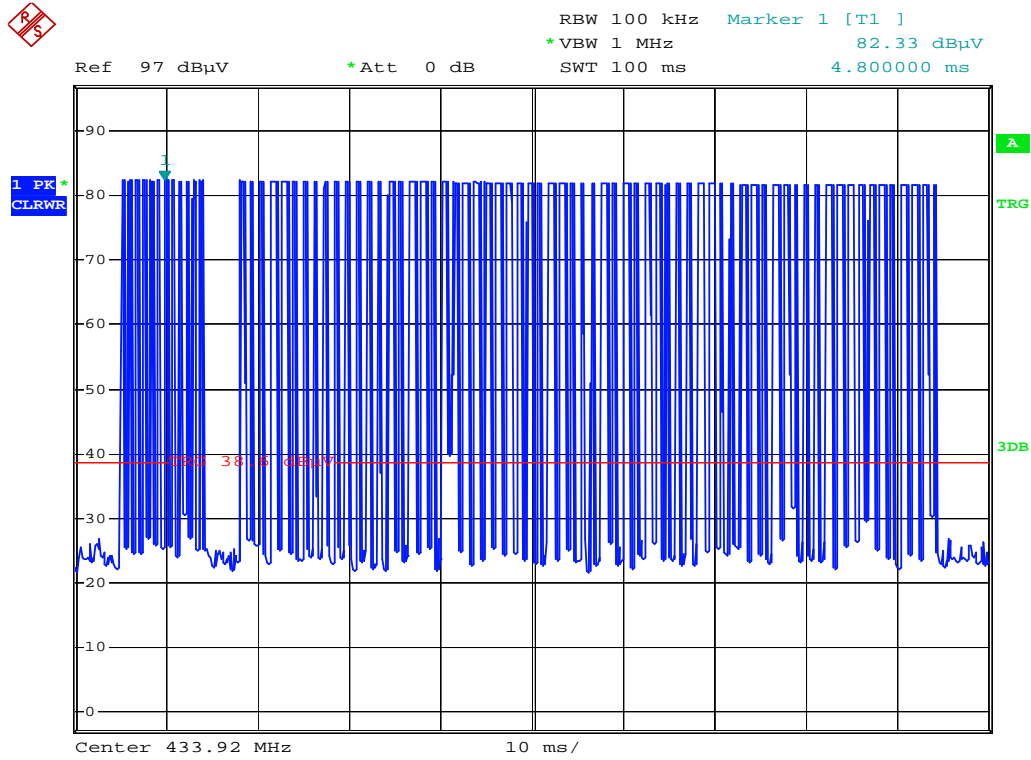

### Time Slot 1

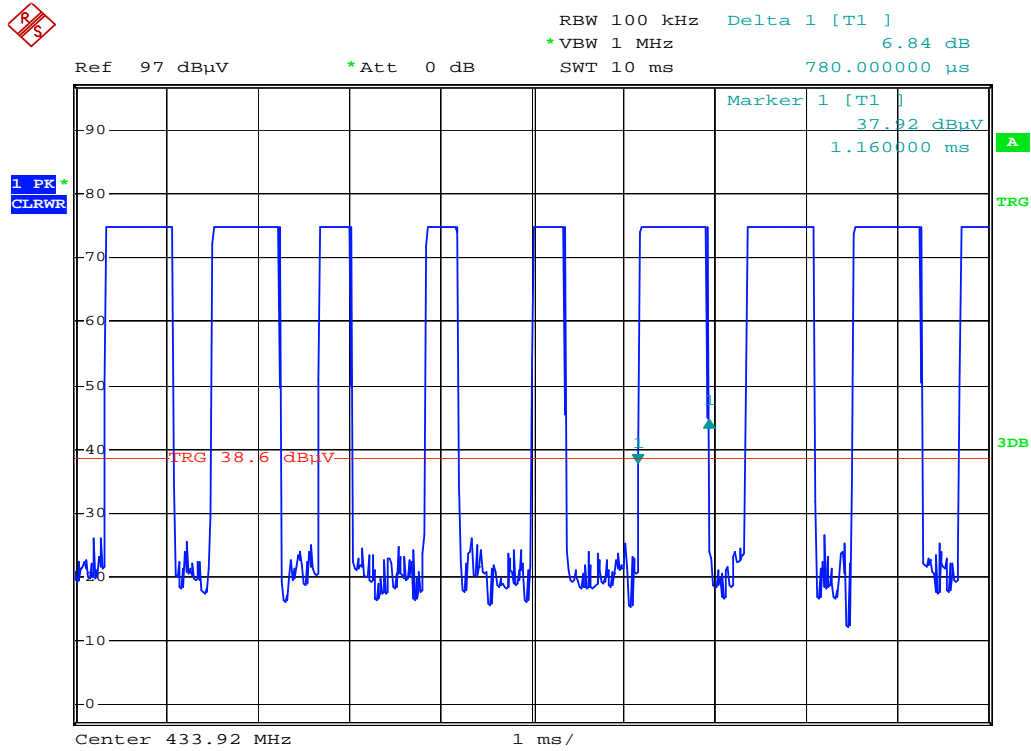

### Time Slot 2

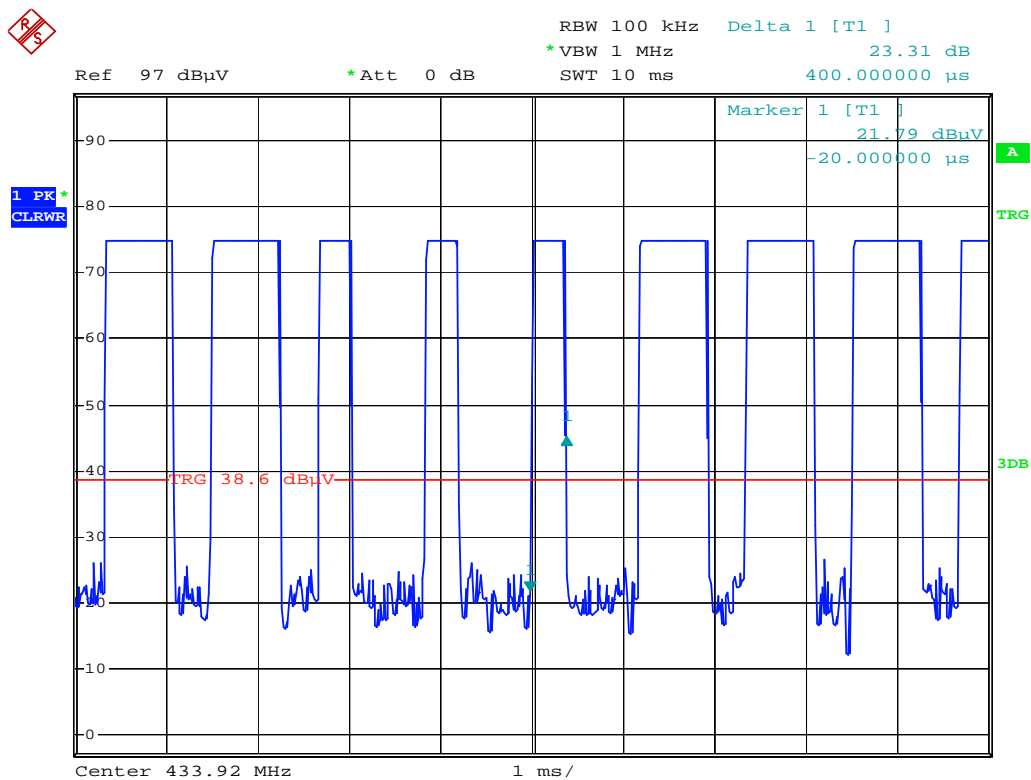

### Time Slot 3

The EUT was complied with the requirement of FCC 15.231 (a)(1), which employed a switch that will automatically deactivate the transmitter within less than 5 seconds of being released.

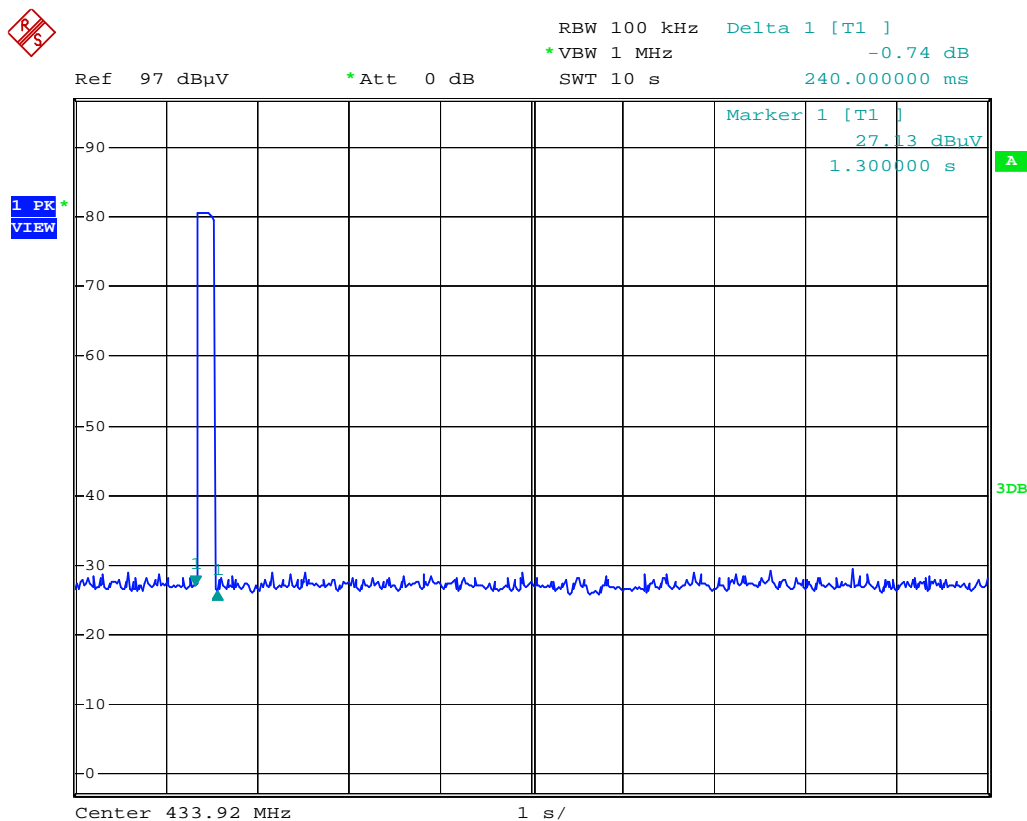

### 4.3 Configuration of Measurement

#### Measurement Frequency under 1GHz

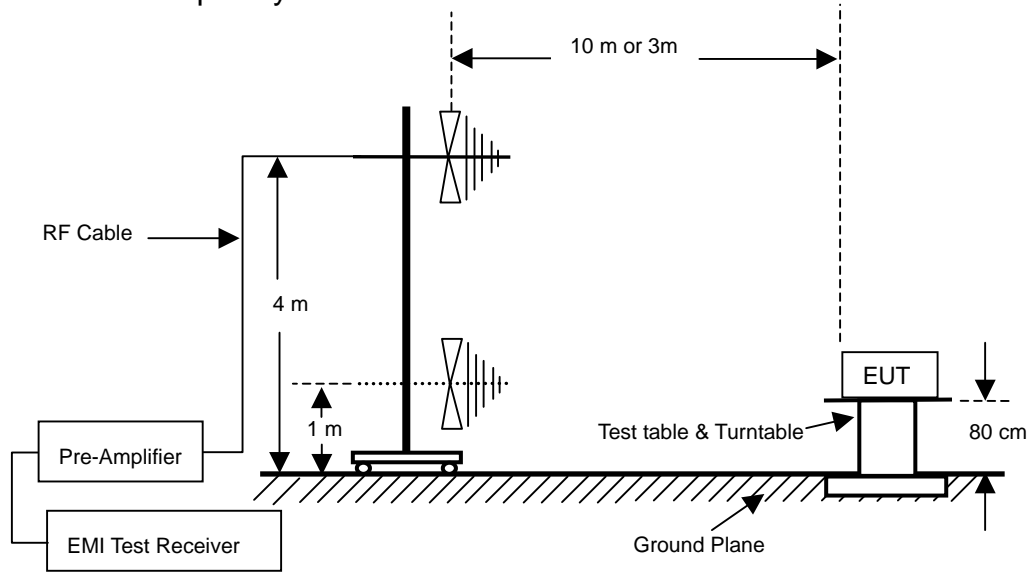

#### Measurement Frequency above 1GHz

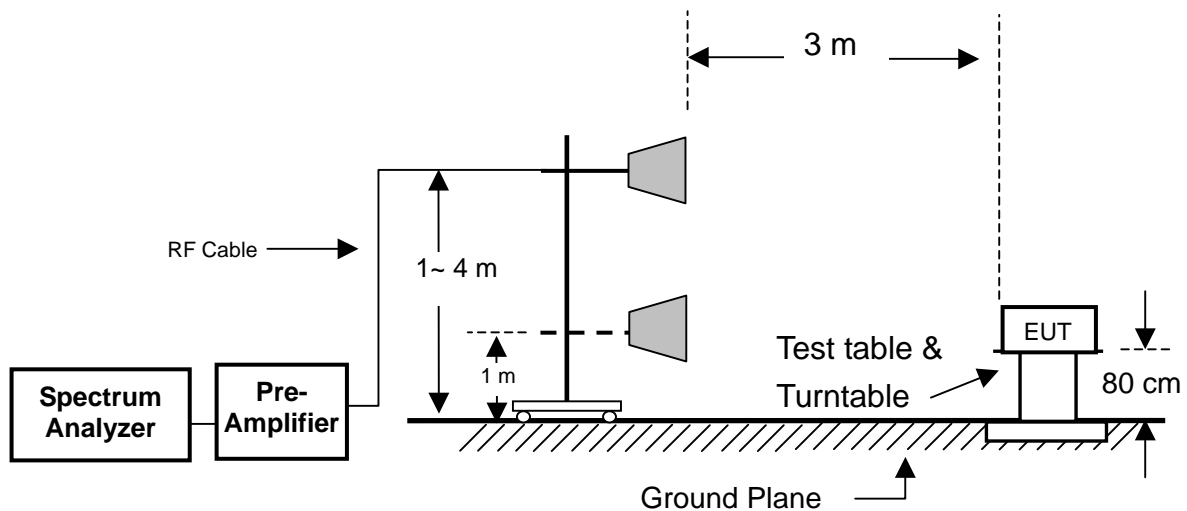

### 4.4 Test Procedure

Radiated emission measurements frequency range were performed from 30MHz to 4GHz. Spectrum Analyzer Resolution Bandwidth set to 100kHz or greater for frequencies from 30MHz to 1GHz, and set 1MHz Resolution Bandwidth for frequencies above 1GHz.

The EUT is place on non-conductive turntable for the test. If peripheral devices apply to the EUT, the peripheral devices will be connected to EUT and whole system. During the emission test, the signal is maximized through rotation and all cables were present worst-case emissions. The height of antenna and polarization is constantly changed for exploring maximum signal reading. The height of antenna can be up form reference ground to 4 meter and down to 1 meter.

### 4.5 Test Result

**PASS.**

The final test emission data is shown as following tables.



## Radiated Emission Below 1GHz

(Worse case X axis)

Frequency	Antenna	Reading	Preamp	Correction Factor	Corrected Level	Limits	Margin	Det
(MHz)	Polarization	(dBuV)	(dB)	(dB/m)	(dBuV/m)	(dBuV/m)	(dB)	Mode
83.47	H	42.50	29.90	8.71	21.31	40.00	-18.69	PK
137.92	H	40.30	30.75	16.34	25.89	43.52	-17.63	PK
207.98	H	38.97	29.86	19.96	29.07	43.52	-14.45	PK
308.77	H	39.80	29.39	17.86	28.27	46.02	-17.75	PK
420.60	H	38.81	29.66	21.05	30.20	46.02	-15.82	PK
594.20	H	34.31	29.68	24.63	29.26	46.02	-16.76	PK
139.78	V	40.62	30.77	17.21	27.06	43.52	-16.46	PK
189.72	V	39.87	29.86	19.89	29.90	43.52	-13.62	PK
257.30	V	41.20	29.64	21.53	33.09	46.02	-12.93	PK
336.00	V	41.20	29.40	18.28	30.08	46.02	-15.94	PK
478.91	V	37.50	30.18	22.05	29.37	46.02	-16.65	PK
637.25	V	34.89	29.84	25.08	30.13	46.02	-15.89	PK

Remark : Corrected Level = Reading + Correction Factor – Preamp  
 Correction Factor = Antenna Factor + Cable Loss

### Fundamental and Harmonics Emissions

Freq.	Antenna	Reading	Preamp	Correction Factor	Average Factor	Corrected Level	Limits	Margin	Det
(MHz)	Polarization	(dBuV)	(dB)	(dB/m)	(dB)	(dBuV/m)	(dBuV/m)	(dB)	Mode
433.92	H	57.26	0.00	21.30	--	78.56	100.8	-22.24	PK
433.92	H	57.26	0.00	21.30	-6.32	72.24	80.8	-8.56	AV
867.84	H	46.75	30.10	29.36	--	46.01	80.8	-34.79	PK
867.84	H	46.75	30.10	29.36	-6.32	39.69	60.8	-21.11	AV
1301.76	H	44.41	27.36	28.11	--	45.16	74.0	-28.84	PK
1301.76	H	44.41	27.36	28.11	-6.32	38.84	54.0	-15.16	AV
1735.68	H	51.19	27.67	29.31	--	52.83	80.8	-27.97	PK
1735.68	H	51.19	27.67	29.31	-6.32	46.51	60.8	-14.29	AV
2169.60	H	40.70	27.80	30.57	--	43.47	80.8	-37.33	PK
2169.60	H	40.70	27.80	30.57	-6.32	37.15	60.8	-23.65	AV
2603.52	H	38.94	27.83	32.14	--	43.25	80.8	-37.55	PK
2603.52	H	38.94	27.83	32.14	-6.32	36.93	60.8	-23.87	AV
3037.44	H	42.65	27.97	33.36	--	48.04	80.8	-32.76	PK
3037.44	H	42.65	27.97	33.36	-6.32	41.72	60.8	-19.08	AV
3471.36	H	43.98	27.79	33.68	--	49.87	80.8	-30.93	PK
3471.36	H	43.98	27.79	33.68	-6.32	43.55	60.8	-17.25	AV
3905.28	H	37.22	27.86	35.88	--	45.24	74.0	-28.76	PK
3905.28	H	37.22	27.86	35.88	-6.32	38.92	54.0	-15.08	AV
4339.20	H	34.56	27.61	36.53	--	43.48	74.0	-30.52	PK
4339.20	H	34.56	27.61	36.53	-6.32	37.16	54.0	-16.84	AV
433.92	V	63.10	0.00	21.06	--	84.16	100.8	-16.64	PK
433.92	V	63.10	0.00	21.06	-6.32	77.84	80.8	-2.96	AV
867.84	V	55.37	30.10	28.94	--	54.21	80.8	-26.59	PK
867.84	V	55.37	30.10	28.94	-6.32	47.89	60.8	-12.91	AV
1301.76	V	49.20	27.36	28.11	--	49.95	74.0	-24.05	PK
1301.76	V	49.20	27.36	28.11	-6.32	43.63	54.0	-10.37	AV
1735.68	V	54.41	27.67	29.31	--	56.05	80.8	-24.75	PK
1735.68	V	54.41	27.67	29.31	-6.32	49.73	60.8	-11.07	AV
2169.60	V	48.58	27.80	30.57	--	51.35	80.8	-29.45	PK
2169.60	V	48.58	27.80	30.57	-6.32	45.03	60.8	-15.77	AV

2603.52	V	41.25	27.83	32.14	--	45.56	80.8	-35.24	PK
2603.52	V	41.25	27.83	32.14	-6.32	39.24	60.8	-21.56	AV
3037.44	V	46.65	27.97	33.36	--	52.04	80.8	-28.76	PK
3037.44	V	46.65	27.97	33.36	-6.32	45.72	60.8	-15.08	AV
3471.36	V	41.03	27.79	33.68	--	46.92	80.8	-33.88	PK
3471.36	V	41.03	27.79	33.68	-6.32	40.60	60.8	-20.20	AV
3905.28	V	39.35	27.86	35.88	--	47.37	74.0	-26.63	PK
3905.28	V	39.35	27.86	35.88	-6.32	41.05	54.0	-12.95	AV
4339.20	V	34.75	27.61	36.53	--	43.67	74.0	-30.33	PK
4339.20	V	34.75	27.61	36.53	-6.32	37.35	54.0	-16.65	AV

Remark :

1. Corrected Level = Reading + Correction Factor – Preamp
2. Correction Factor = Antenna Factor + Cable Loss
3. “ \* ” Mark indicated Background Noise Level
4. The signal bandwidth was measured and less then 100KHz RBW so PDCF factor is not required to correct the fundamental signal peak result.

## 5 Emission Bandwidth

### 5.1 Limits

According to FCC 15.231(c) requirement:

The bandwidth of the emission shall be no wider than 0.25% of the center frequency for devices operating between 70 MHz to 900 MHz. Those devices operating above 900 MHz, the emission spurious shall be no wider than 0.5% of the center frequency. Bandwidth is determined at the points 20 dB down from the modulated carrier.

B.W (20dBc) Limit = 0.25% \* f(MHz) = 0.25% \* 433.92MHz = 1084.8kHz

### 5.2 Test Result

**PASS.**

The final test data is shown as following.

Channel Frequency (MHz)	Measured 20dB Bandwidth (kHz)	Limit (kHz)	Result
433.92	53.4	1084.8	PASS

