

# 47 CFR Part 15 Subpart C

## Section 15.231

### Test Report

Product : Transmitter

Trade Name : N/A

Model Number : CARF-AM4; SLRF-AM4

FCC ID : ELVMTUB

Prepared for

#### **Nutek Corporation**

No.167, Lane 235, Bauchiau Rd., Xindian District,  
New Taipei City 23145, Taiwan

TEL. : +886 2 2918 9478

FAX. : +886 2 2917 9069

Prepared by

#### **Interocean EMC Technology Corp.**

**Interocean EMC Technology Tin-Fu Laboratory**  
No. 5-2, Lin 1, Tin-Fu, Lin-Kou Dist., New Taipei City,  
Taiwan 244, R.O.C.

TEL.: +886 2 2600 6861

FAX.: +886 2 2600 6859



#### **Remark:**

The test report consists of **25** pages in total. It shall not be reproduced except in full, without the written approval of IETC. This document may be altered or revised by IETC only, and shall be noted in the revision section of the document.  
The test result in this report is only subjected to the test sample.

# Table of Contents

<b>1</b>	<b>General Information</b>	<b>4</b>
1.1	Description of Equipment Under Test	4
1.2	Test Facility	5
1.3	Test Equipment	6
1.4	Measurement Uncertainty	6
1.5	Summary of Measurement	7
<b>2</b>	<b>Test Specifications</b>	<b>8</b>
2.1	Test Standard	8
2.2	Operation Mode	8
2.3	Test Step of EUT	8
<b>3</b>	<b>Duty Cycle</b>	<b>9</b>
3.1	Limits	9
3.2	Test Procedure	9
3.3	Test Result	9
<b>4</b>	<b>Transmitter Deactivation Time</b>	<b>12</b>
4.1	Limits	12
4.2	Test Procedure	12
4.3	Test Result	12
<b>5</b>	<b>Radiated Emission Test</b>	<b>13</b>
5.1	Limits	13
5.2	Configuration of Measurement	14
5.3	Test Procedure	14
5.4	Test Result	14
<b>6</b>	<b>Emission Bandwidth</b>	<b>19</b>
6.1	Limits	19
6.2	Test Procedure	19
6.3	Test Result	19
<b>7</b>	<b>Photographs of Test</b>	<b>20</b>
7.1	Radiated Emission Measurement (Below 1 GHz)	20
7.2	Radiated Emission Measurement (Above 1 GHz)	20
<b>8</b>	<b>Photographs of EUT</b>	<b>21</b>
8.1	Model No.: CARF-AM4	21

# Statement of Compliance

**Applicant:** Nutek Corporation  
**Manufacturer:** Nutek Corporation  
**Product:** Transmitter  
**Model No.:** CARF-AM4; SLRF-AM4  
**Tested Power Voltage:** DC 3V  
**Date of Final Test:** Apr. 20, 2021  
**Revision of Report:** Rev. 01

**Configuration of Measurements and Standards Used :**

FCC Rules and Regulations Part 15 Subpart C

I HEREBY CERTIFY THAT: The data shown in this report were made in accordance with the procedures given in ANSI C63.10, and the energy emitted by the device was founded to be within the limits applicable. I assume full responsibility for accuracy and completeness of these data.

- Note:**
1. The result of the testing report relate only to the item tested.
  2. This report shall not be partial reproduced without written approval by Interocean EMC Technology Corporation.
  3. Judgment of conformity is based on test result, regardless of measurement uncertainty.

Report Issued: 2021/05/07

Prepared by: Ivan Wang  
Ivan Wang

Approved: Jerry Chang  
Jerry Chang

## 1 General Information

### 1.1 Description of Equipment Under Test

<b>Product</b>	: Transmitter
<b>Model Number</b>	: CARF-AM4; SLRF-AM4
<b>Applicant</b>	: <b>Nutek Corporation</b> No.167, Lane 235, Bauchiau Rd., Xindian District, New Taipei City 23145, Taiwan
<b>Manufacturer</b>	: <b>Nutek Corporation</b> No.167, Lane 235, Bauchiau Rd., Xindian District, New Taipei City 23145, Taiwan
<b>Power Supply</b>	: DC 3V
<b>Operating Frequency</b>	: 433.92 MHz
<b>Output Power</b>	: 77.22 dB $\mu$ V/m
<b>Type of Modulation</b>	: ASK
<b>Antenna Description</b>	: PCB Antenna. maximum Peak gain: 0dBi.
<b>Measurement Software</b>	: e3; Ver: 8.120803a7-2
<b>Receipt Date of EUT</b>	: Mar. 29, 2021
<b>Date of Test</b>	: Apr. 19 ~ 20, 2021
<b>Additional Description</b>	: 1) The test model is " <b>CARF-AM4</b> ", designated by the applicant and included in this report. 2) The differences of all models included in this report are provided by the applicant, and the lab disclaims any liability related to reporting, if incorrect, from such provision. The difference of all models is only for different market. 3) For more detailed specification about EUT, please refer to the user's manual.

## 1.2 Test Facility

- Site Description** : ☒ Chamber 3
- Name of Firm** : Interocean EMC Technology Corp.
- Company web** : <http://www.ietc.com.tw>
- Location** : No. 5-2, Lin 1, Tin-Fu, Lin-Kou Dist., New Taipei City, Taiwan 244, R.O.C.
- Site Filing** :
- Federal Communication Commissions – USA  
Designation No.: TW1020 (Test Firm Registration #: 651092)  
Designation No.: TW1113 (Test Firm Registration #: 959554)
  - Innovation, Science and Economic Development Canada (ISED)  
CAB identifier: TW1113 (Ref. No 14962756)
  - Voluntary Control Council for Interference by Information Technology Equipment (VCCI) – Japan  
Member No.: 1349  
Registration No. (Conducted Room): C-11094  
Registration No. (Conducted Room): T-11562  
Registration No. (OATS 1): R-11040  
Registration No. (Chamber 3): G-20080
- Site Accreditation** :
- Bureau of Standards and Metrology and Inspection (BSMI) – Taiwan, R.O.C.  
Accreditation No.:  
SL2-IN-E-0026 for CNS 13438 / CISPR 22  
SL2-R1-E-0026 for CNS 13439 / CISPR 13  
SL2-R2-E-0026 for CNS 13439 / CISPR 13  
SL2-L1-E-0026 for CNS 14115 / CISPR 15
  - Taiwan Accreditation Foundation (TAF)  
Accreditation No.: 1113
  - American Association for Laboratory Accreditation (A2LA)  
Certificate Number: 4891.01
  - Vehicle Safety Certification Center (VSCC)  
Approval No.: TW16-11

### 1.3 Test Equipment

Instrument	Manufacturer	Model	Serial No.	Next Cal. Date
EMI Test Receiver	R&S	ESI7	830154/002	2021/05/05
Spectrum Analyzer	R&S	FSP30	100002	2021/05/12
Loop Antenna	Electro-Metrics	EM-6879	261	2021/09/16
Bilog Antenna	ETC	MCTD 2786B	BLB17S04020	2021/05/04
Horn Antenna	Schwarzbeck	BBHA9120	9120D-1051	2021/08/03
Pre-Amplifier	EMCI	EMC001150	980130	2021/08/02
Pre-Amplifier	EMCI	EMC051845	980110	2021/07/02
RF Cable	HARBOUR	27478LL142	CBL65	2021/07/28
RF Cable	Marvelous Microwave	MCBL-LL266.50	CBL70	2021/07/28
Measurement Software	AUDIX-e3			

Note: The above equipments are within the valid calibration period.

### 1.4 Measurement Uncertainty

Item	Value
Chamber 3:	
Radiated Emission Test (9 kHz to 30 MHz)	3.2 dB
Radiated Emission Test (30 MHz to 200 MHz)	4.6 dB
Radiated Emission Test (200 MHz to 1 GHz) (Antenna: without tilting)	5.9 dB
Radiated Emission Test (1 GHz to 18 GHz)	5.0 dB
Radiated Emission Test (18 GHz to 40 GHz)	5.4 dB
The reported expanded uncertainty is based on a standard uncertainty multiplied by a coverage factor of k=2, providing a level of confidence of approximately 95%	

### 1.5 Summary of Measurement

<b>Test Parameter</b>	<b>Reference Document 47 CFR Part15</b>	<b>Results</b>
Occupied Bandwidth	FCC Part 15: 15.231(c)	Pass
Transmission time and silent time	§15.231(a)(1)	Pass
Radiated Emission	FCC Part 15: 15.209 FCC Part 15: 15.231(b)	Pass
Power Line Conducted Emissions	FCC Part 15: 15.207	N/A
Antenna requirement	FCC Part 15: 15.203	Pass
Note: N/A is an abbreviation for Not Applicable.		

## **2 Test Specifications**

### **2.1 Test Standard**

The EUT was performed according to FCC Part 15 Subpart C Section 15.231 procedure and setup followed by ANSI C63.10-2013 requirements.

### **2.2 Operation Mode**

By preliminary testing and verifying three axis (X, Y and Z) position of EUT transmitted status, it was found that "Y axis" position was the worst, then the final test was executed the worst condition and test data were recorded in this report.

### **2.3 Test Step of EUT**

- 2.3.1 Set the fixture to EUT for power supplying.
- 2.3.2 Turn on the power of all equipments.
- 2.3.3 Let the EUT continuous transmission.
- 2.3.4 Execute the test.



### 3 Duty Cycle

#### 3.1 Limits

No dedicated limit specified in the Rules.

#### 3.2 Test Procedure

The EUT was directly connected to the spectrum analyzer and antenna output port as show in the block diagram below. The Duty Cycle Was Determined By the Following Equation: To Calculate The Actual Field Intensity, The Duty Cycle Correction Factor In Decibel is needed for later use and can be obtained from following convvesion  $Duty\ Cycle\ (\%) = Total\ on\ interval\ in\ A\ compleere\ pulse\ train / Length\ of\ A\ complete\ pulse\ train * \% \text{ Duty Cycle Correnction Factor (dB)} = 20 * \log_{10}(Duty\ Cycle\ (\%))$

#### 3.3 Test Result

$T_p = 100.00(ms)$

$T_{on} = 2750 * 1 + 1950 * 1 + 450 * 66 = 34.40(ms)$

$Factor = 20 * \log(T_{on} / T_p) = 20 * \log(34.40/100.00) = -9.27dB$

Plot:

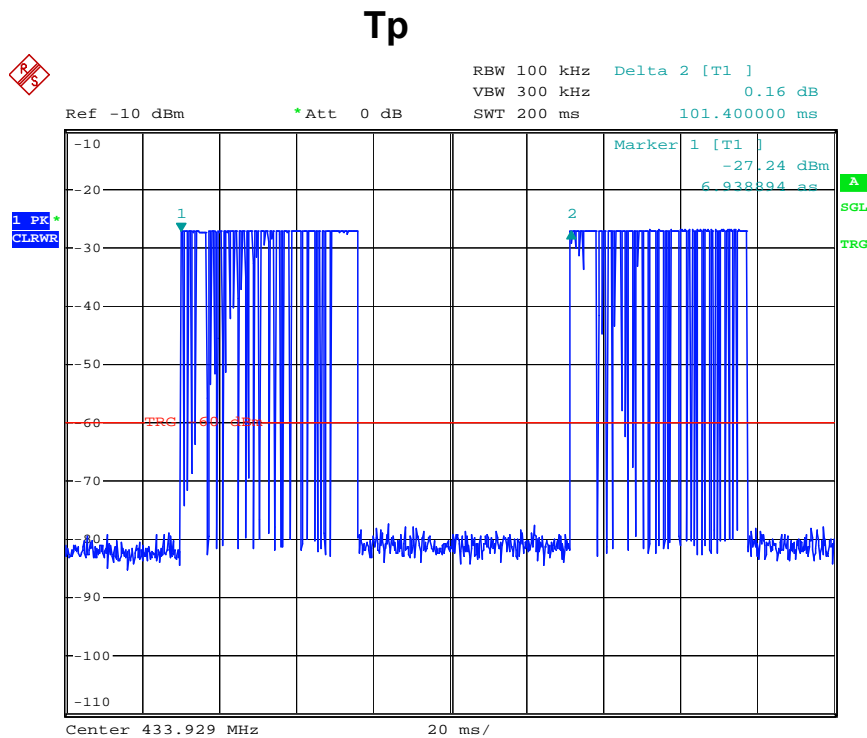

Date: 19.APR.2021 12:57:08

# Ton 1

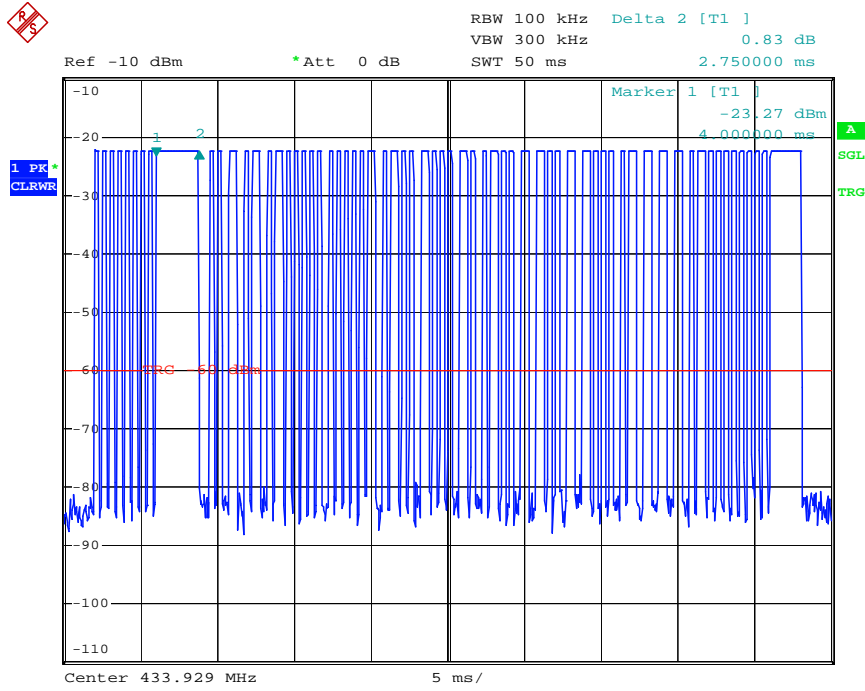

Date: 19.APR.2021 12:58:29

# Ton 2

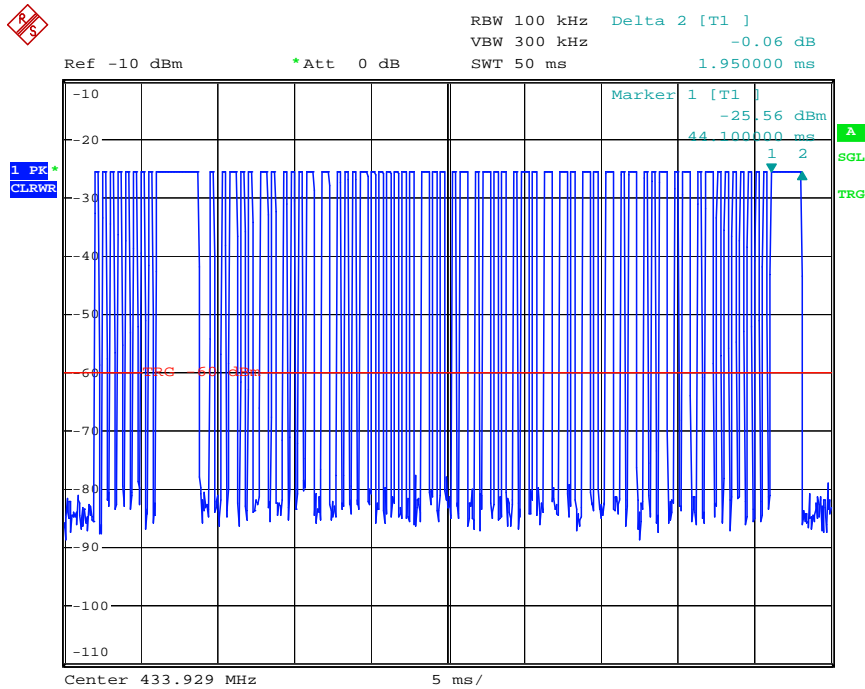

Date: 19.APR.2021 12:59:06

### Ton 3

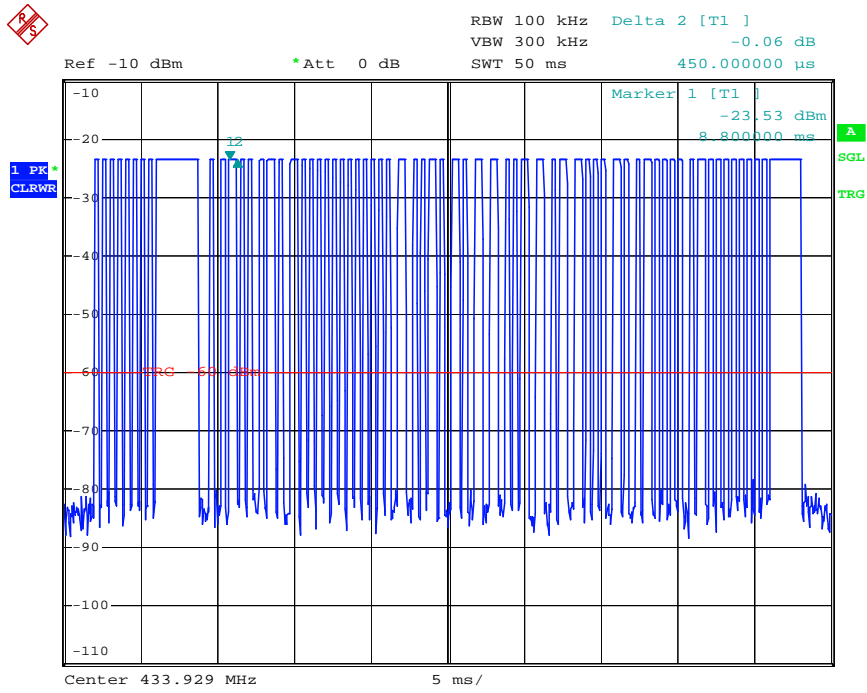

Date: 19.APR.2021 12:59:58

## 4 Transmitter Deactivation Time

### 4.1 Limits

FCC 15.231 (a)(1)

A manually operated transmitter shall employ a switch that will automatically deactivate the transmitter within not more than 5 seconds of being released.

### 4.2 Test Procedure

Release the switch after pressing the switch.

### 4.3 Test Result

Frequency (MHz)	Activation time (Sec)	Limit (Sec)	Test conclusion
433.92	0.441	5	PASS

Plot:

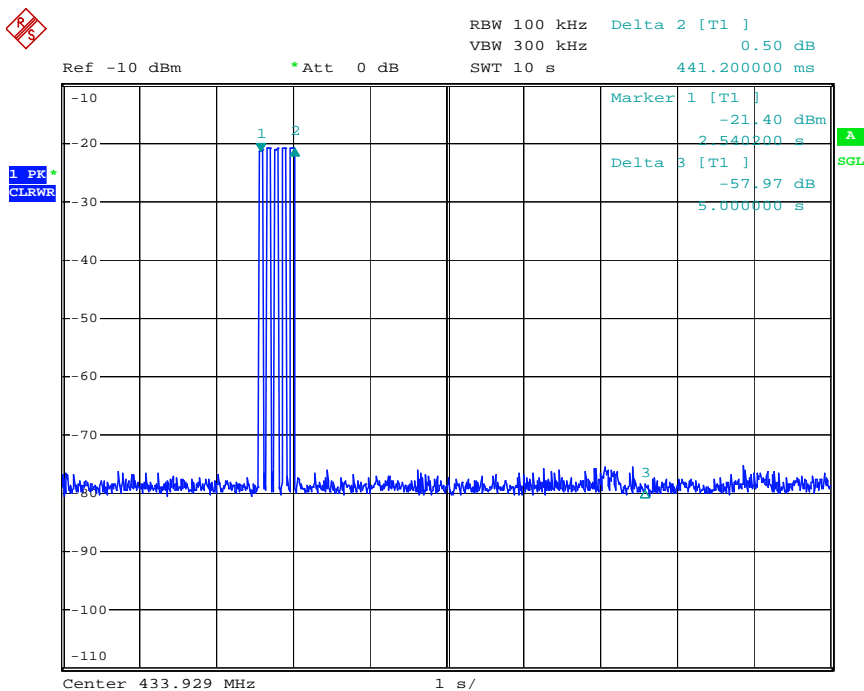

Date: 19.APR.2021 12:54:54

## 5 Radiated Emission Test

### 5.1 Limits

According to FCC 15.231(b) requirement:

In addition to the provisions of §15.205, the field strength of emissions from intentional radiator operated under this section shall not exceed the following:

#### Fundamental and Harmonics Emission Limits

Fundamental frequency (MHz)	Field strength of fundamental (microvolts/meter)	Field strength of spurious emissions (microvolts/meter)
40.66-40.70	2,250	225
70-130	1,250	125
130-174	<sup>1</sup> 1,250 to 3,750	<sup>1</sup> 125 to 375
174-260	3,750	375
260-470	<sup>1</sup> 3,750 to 12,500	<sup>1</sup> 375 to 1,250
Above 470	12,500	1,250

#### General Radiated Emission Limit

Spurious Emission tested through until 10<sup>th</sup> harmonic. Radiated emissions, which fall in the restricted bands, as defined in §15.205 (a), comply with the radiated emission limits specified in §15.209 (a).

Frequency (MHz)	15.209 Limits	
	( $\mu$ V/m@3m)	(dB $\mu$ V/m@3m)
30 - 88	100	40
88 - 216	150	43.5
216 - 960	200	46
Above 960	500	54

Remark :

1. The table above tighter limit applies at the band edges.
2. The measurement distance in meters, which that between form closest point of EUT to instrument antenna.

## 5.2 Configuration of Measurement

### Measurement Frequency under 1 GHz

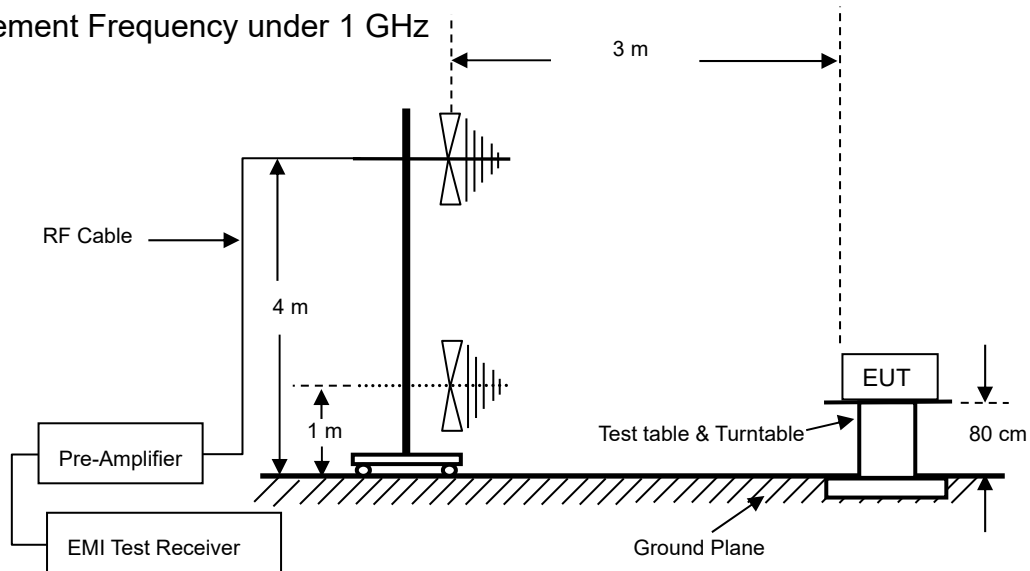

### Measurement Frequency above 1 GHz

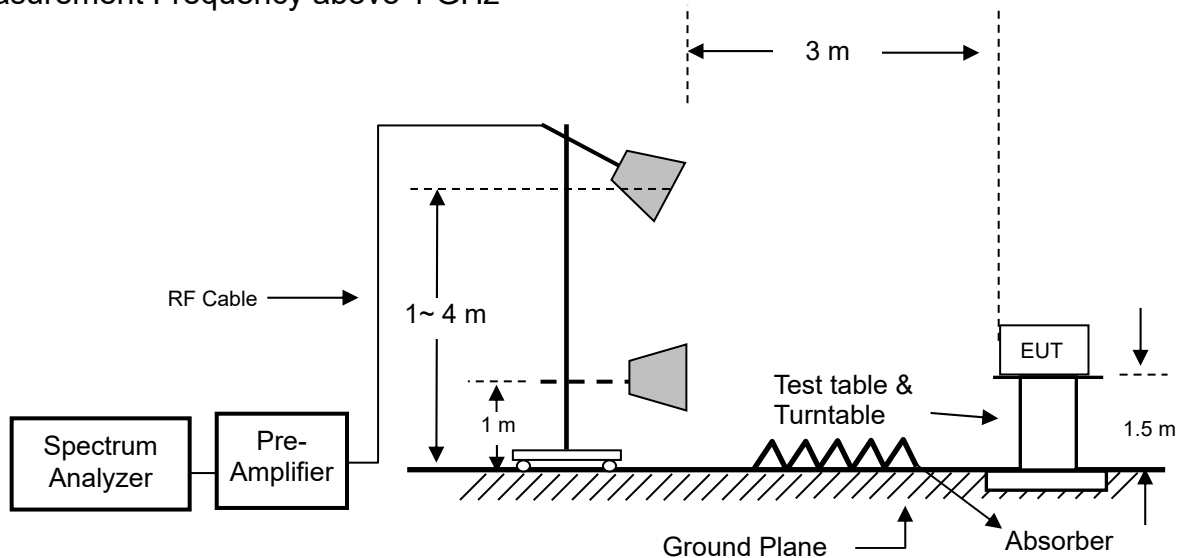

## 5.3 Test Procedure

Radiated emission measurements frequency range were performed from 9 kHz to 5 GHz. Spectrum Analyzer Resolution Bandwidth set to 9 kHz for frequencies below 30 MHz, set 100 kHz or greater for frequencies from 30 MHz to 1 GHz, and set 1MHz Resolution Bandwidth for frequencies above 1 GHz.

The EUT is place on non-conductive turntable for the test. If peripheral devices apply to the EUT, the peripheral devices will be connected to EUT and whole system. During the emission test, the signal is maximized through rotation and all cables were present worst-case emissions. The height of antenna and polarization is constantly changed for exploring maximum signal reading. The height of antenna can be up form reference ground to 4 meter and down to 1 meter.

## 5.4 Test Result

The frequency range from 9 kHz to 30 MHz was pre-scanned and the results were 20 dB lower than the limit line which according to FCC 15.31(o) needs not be recorded.

The final test emission data is shown as following tables.

## Radiated Emission Below 1 GHz

CLIENT: Nutek Corporation  
 EUT: Transmitter  
 MODEL: CARF-AM4  
 RATING: DC 3V  
 COMMENT: 433.92-X-H-30-1G  
 Data:91

OPERATOR : Scott  
 TEST SITE : Chamber 3  
 TEST DISTANCE : 3 m  
 POLARIZATION : HORIZONTAL  
 TEMP/HUM : 24.5°C/50%  
 2021-04-20

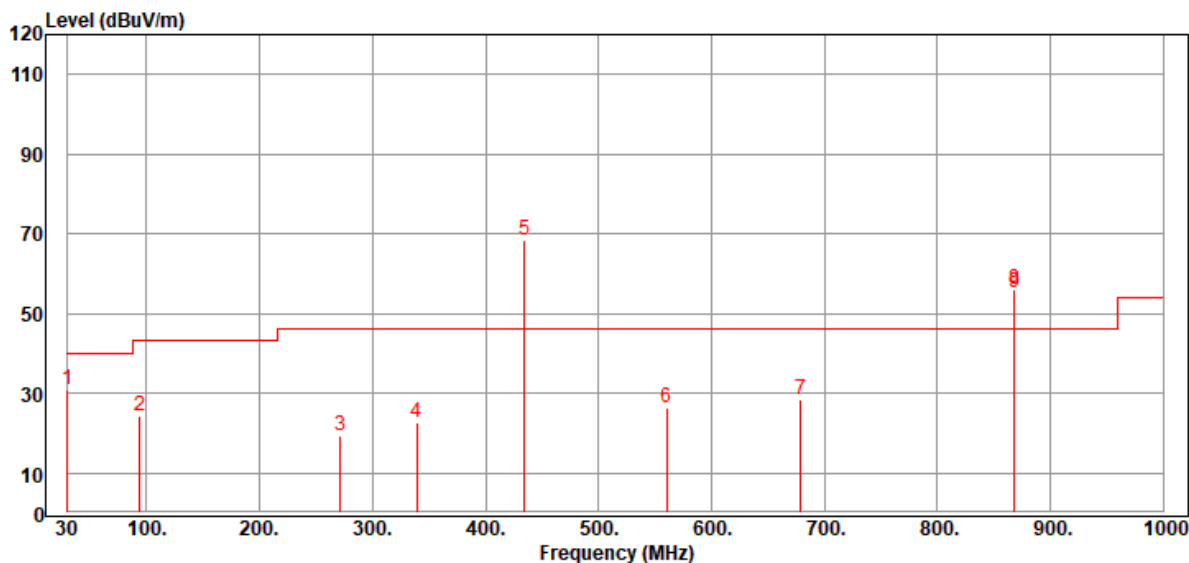

Item Mark	Freq. MHz	Reading dBuV	Factor dB/m	Level dBuV/m	Limit dBuV/m	Margin dB	Remark
1	30.000	61.72	-30.97	30.75	40.00	-9.25	Peak
2	94.020	58.86	-34.53	24.33	43.50	-19.17	Peak
3	271.530	50.15	-30.60	19.55	46.02	-26.47	Peak
4	339.430	51.60	-28.87	22.73	46.02	-23.29	Peak
5	434.490	95.24	-26.91	68.33	100.82	-32.49	Peak
	434.490		-9.21	59.12	80.82	-21.70	Average
6	560.590	52.44	-26.12	26.32	46.02	-19.70	Peak
7	678.930	52.98	-24.51	28.47	46.02	-17.55	Peak
8	868.080	76.55	-21.21	55.34	80.82	-25.48	Peak
	868.080		-9.27	46.07	60.82	-14.75	Average

Remark : Corrected Level = Reading + Correction Factor – Preamp  
 Correction Factor = Antenna Factor + Cable Loss  
 Margin = Corrected Level – Limits  
 “ \* ” Mark indicated Background Noise Level  
 Avg Level=Peak Level – Factor

CLIENT: Nutek Corporation  
 EUT: Transmitter  
 MODEL: CARF-AM4  
 RATING: DC 3V  
 COMMENT: 433.92-X-V-30-1G  
 Data:90

OPERATOR : Scott  
 TEST SITE : Chamber 3  
 TEST DISTANCE : 3 m  
 POLARIZATION : VERTICAL  
 TEMP/HUM : 24.5°C/50%  
 2021-04-20

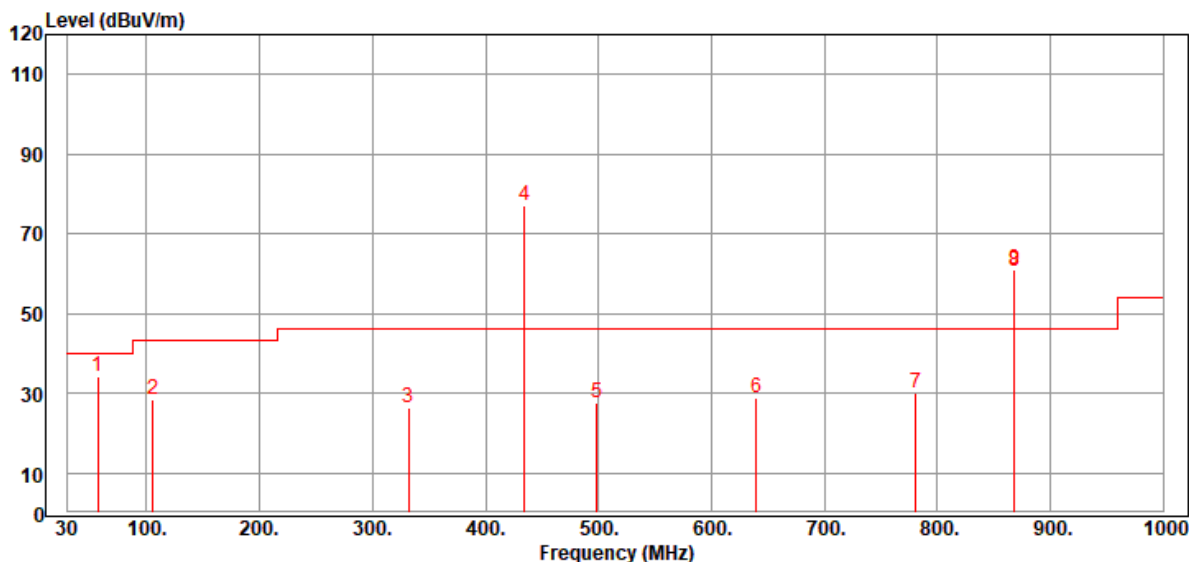

Item Mark	Freq. MHz	Reading dBuV	Factor dB/m	Level dBuV/m	Limit dBuV/m	Margin dB	Remark
1	57.160	69.25	-34.82	34.43	40.00	-5.57	Peak
2	105.660	59.20	-30.94	28.26	43.50	-15.24	Peak
3	331.670	55.36	-29.00	26.36	46.02	-19.66	Peak
4	434.490	104.13	-26.91	77.22	100.82	-23.60	Peak
	434.490		-9.27	67.95	80.82	-12.87	Average
5	498.510	53.87	-26.32	27.55	46.02	-18.47	Peak
6	640.130	53.52	-24.85	28.67	46.02	-17.35	Peak
7	780.780	52.86	-22.96	29.90	46.02	-16.12	Peak
8	868.080	82.09	-21.21	60.88	80.82	-19.94	Peak
	868.080		-9.27	51.61	60.82	-9.21	Average

Remark : Corrected Level = Reading + Correction Factor – Preamp  
 Correction Factor = Antenna Factor + Cable Loss  
 Margin = Corrected Level – Limits  
 “ \* ” Mark indicated Background Noise Level  
 Avg Level=Peak Level – Factor



## Radiated Emission Above 1 GHz

CLIENT: Nutek Corporation

EUT: Transmitter

MODEL: CARF-AM4

RATING: DC 3V

COMMENT: 433.92-X-H-1G-4.5G

Data:82

OPERATOR : Scott

TEST SITE : Chamber 3

TEST DISTANCE : 3 m

POLARIZATION : HORIZONTAL

TEMP/HUM : 24.5°C/50%

2021-04-20

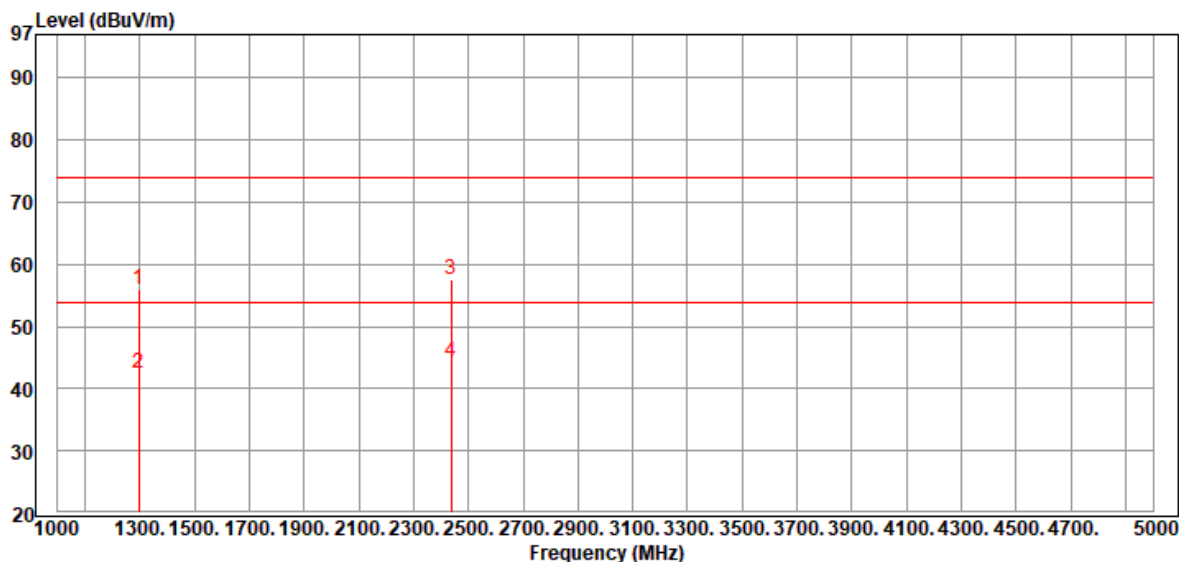

Item Mark	Freq. MHz	Reading dBuV	Factor dB/m	Level dBuV/m	Limit dBuV/m	Margin dB	Remark
1	1296.000	68.09	-12.05	56.04	74.00	-17.96	Peak
2	1296.000	54.55	-12.05	42.50	54.00	-11.50	Average
3	2436.000	66.37	-8.91	57.46	74.00	-16.54	Peak
4	2436.000	53.20	-8.91	44.29	54.00	-9.71	Average

Remark : Corrected Level = Reading + Correction Factor – Preamp

Correction Factor = Antenna Factor + Cable Loss

Margin = Corrected Level – Limits

“ \* ” Mark indicated Background Noise Level

Avg Level=Peak Level – Factor

CLIENT: Nutek Corporation  
 EUT: Transmitter  
 MODEL: CARF-AM4  
 RATING: DC 3V  
 COMMENT: 433.92-X-V-1G-4.5G  
 Data:83

OPERATOR : Scott  
 TEST SITE : Chamber 3  
 TEST DISTANCE : 3 m  
 POLARIZATION : VERTICAL  
 TEMP/HUM : 24.5°C/50%  
 2021-04-20

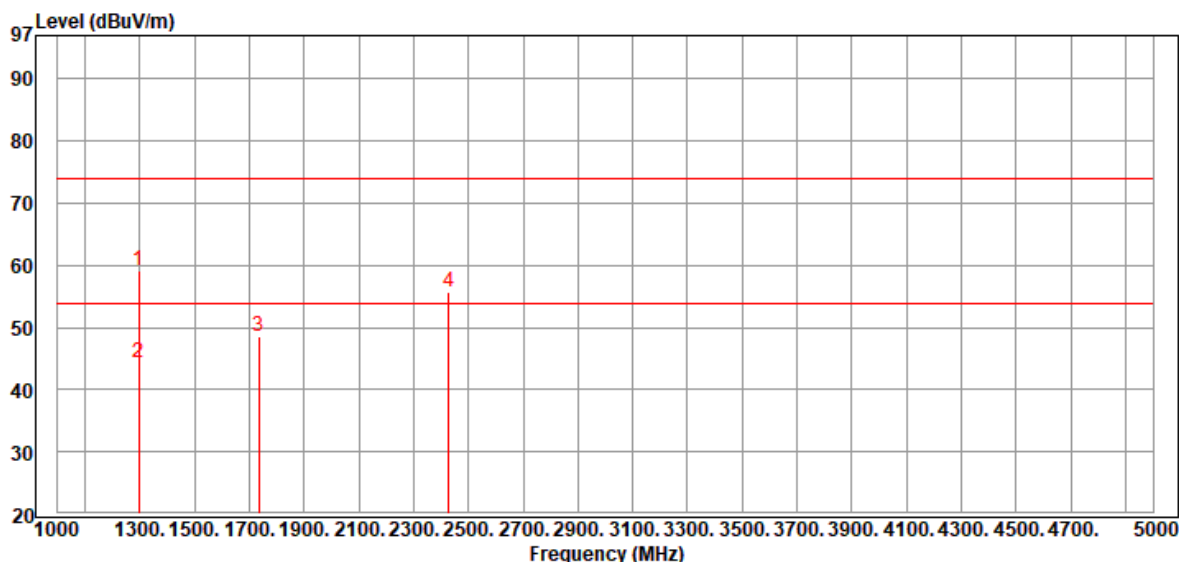

Item Mark	Freq. MHz	Reading dBuV	Factor dB/m	Level dBuV/m	Limit dBuV/m	Margin dB	Remark
1	1296.000	71.25	-12.05	59.20	74.00	-14.80	Peak
2	1296.000	56.41	-12.05	44.36	54.00	-9.64	Average
3	1736.000	60.68	-12.02	48.66	54.00	-5.34	Peak
4	2428.000	64.51	-8.91	55.60	74.00	-18.40	Peak
	2428.000		-9.27	46.33	54.00	-7.67	Average

Remark : Corrected Level = Reading + Correction Factor – Preamp  
 Correction Factor = Antenna Factor + Cable Loss  
 Margin = Corrected Level – Limits  
 “ \* ” Mark indicated Background Noise Level  
 Avg Level=Peak Level – Factor

## 6 Emission Bandwidth

### 6.1 Limits

According to FCC 15.231(c) requirement:

The bandwidth of the emission shall be no wider than 0.25% of the center frequency for devices operating between 70 MHz to 900 MHz. Those devices operating above 900 MHz, the emission spurious shall be no wider than 0.5% of the center frequency. Bandwidth is determined at the points 20 dB down from the modulated carrier.

$$B.W (20dBc) \text{ Limit} = 0.25\% * f(\text{MHz}) = 0.25\% * 433.92 \text{ MHz} = 1084.8 \text{ kHz}$$

### 6.2 Test Procedure

With the EUT's antenna attached, the EUT's 20dB Bandwidth power was received by the test antenna which was connected to the spectrum analyzer with the START and STOP frequencies set to the EUT's operation band.

### 6.3 Test Result

**PASS.**

The final test data is shown as following.

Channel Frequency (MHz)	Measured 20dB Bandwidth (kHz)	Limit (kHz)	Result
433.92	42	1084.8	PASS

Plot:

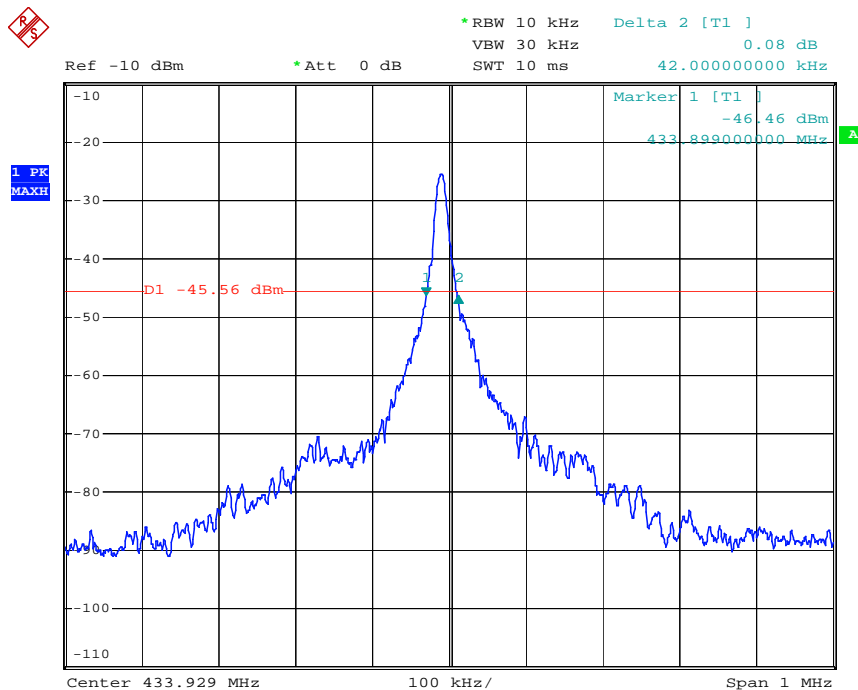

Date: 19.APR.2021 13:02:47