



Willow Run Test Labs, LLC
8501 Beck Road, Building 2227
Belleville, Michigan 48111 USA
Tel: (734) 252-9785
Fax: (734) 926-9785
e-mail: info@wrtest.com

Testing of
Electromagnetic Emissions

per

USA: CFR Title 47, Part 15.247 (Emissions)
USA: CFR Title 47, Part 2.1091;2.1093 (Exposure)
Canada: ISED RSS-247/GENE (Emissions)
Canada: ISED RSS-102 (Exposure)

are herein reported for

Nutek Corporation
4360568

Test Report No.: 20160407-RPTVOXX10001Cr1
Copyright © 2016

Applicant/Provider:
Nutek Corporation

No.167, Lane 235, Bauchiau Rd., Shindian City Taipei 23145 Taiwan
Phone: +88 622 918 9478, Fax: +88 622 917 9069
Contact Person: Jason Wang; jason-w@nutek.com.tw

Measured by:

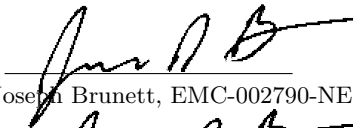
Dr. Joseph Brunett, EMC-002790-NE

Report Approved by:

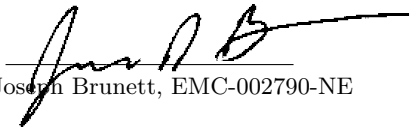
Dr. Joseph Brunett, EMC-002790-NE

Report by:

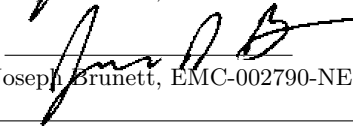
Dr. Joseph Brunett, EMC-002790-NE

Report Date of Issue:

April 7, 2016

Results of testing completed on (or before) March 16, 2016 are as follows.

Emissions: The transmitter intentional emissions **COMPLY** with the regulatory limit(s) by no less than 11.1 dB.
Transmit chain spurious or harmonic emissions **COMPLY** by no less than 3.0 dB.

Contents

1	Test Specifications, General Procedures, and Location	4
1.1	Test Specification and General Procedures	4
1.2	Test Location and Equipment Used	5
2	Configuration and Identification of the Equipment Under Test	6
2.1	Description and Declarations	6
2.1.1	EUT Configuration	6
2.1.2	Modes of Operation	6
2.1.3	Variants	6
2.1.4	Test Samples	7
2.1.5	Functional Exerciser	7
2.1.6	Modifications Made	7
2.1.7	Production Intent	7
2.1.8	Declared Exemptions and Additional Product Notes	7
3	Emissions	8
3.1	General Test Procedures	8
3.1.1	Radiated Test Setup and Procedures	8
3.1.2	Conducted Emissions Test Setup and Procedures	10
3.1.3	Power Supply Variation	10
3.1.4	Thermal Variation	10
3.2	Intentional Emissions	11
3.2.1	Duty and Transmission Cycle, Pulsed Operation	11
3.2.2	Hopping Channel Dwell Time	11
3.2.3	Channel Bandwidth	13
3.2.4	Number of Hopping Channels	15
3.2.5	Channel Separation	15
3.2.6	Effective Isotropic Radiated Power	17
3.2.7	Exposure and Potential Health Hazard	19
3.3	Unintentional Emissions	20
3.3.1	Transmit Chain Spurious Emissions	20
3.3.2	Relative Transmit Chain Spurious Emissions	21
4	Measurement Uncertainty	22

List of Tables

1	Willow Run Test Labs, LLC Equipment List	5
2	EUT Declarations.	6
3	Pulsed Emission Characteristics (Duty Cycle).	11
4	Hopping Channel Dwell Time.	11
5	Intentional Emission Bandwidth.	13
6	Measured Number of Hopping Channels.	15
7	Measured Channel Separation.	15
8	Radiated Power Results.	17
9	Electromagnetic Field Exposure.	19
10	Transmit Chain Spurious Emissions.	20
11	Measurement Uncertainty.	22

List of Figures

1	Photos of EUT.	6
2	EUT Test Configuration Diagram.	7
3	Radiated Emissions Diagram of the EUT.	8
4	Radiated Emissions Test Setup Photograph(s).	9
5	Conducted RF Test Setup Photograph(s).	10
6	Example Plots of Duty Cycle and Channel Dwell Time.	12
7	Intentional Emission Bandwidth.	14
8	Measured Channel Separation.	16
9	Conducted RF Power Plots	18
10	Conducted Transmitter Emissions Measured.	21

1 Test Specifications, General Procedures, and Location

1.1 Test Specification and General Procedures

The ultimate goal of Nutek Corporation is to demonstrate that the Equipment Under Test (EUT) complies with the Rules and/or Directives below. Detailed in this report are the results of testing the Nutek Corporation 4360568 for compliance to:

Country/Region	Rules or Directive	Referenced Section(s)
United States	Code of Federal Regulations	CFR Title 47, Part 15.247
Canada	ISED Canada	ISED RSS-247/GENe

Nutec Corporation has determined that the equipment under test is subject to the rules and directives above at the date of this testing. In conjunction with these rules and directives, the following specifications and procedures are followed herein to demonstrate compliance (in whole or in part) with these regulations.

ANSI C63.4:2014	"Methods of Measurement of Radio-Noise Emissions from Low-Voltage Electrical and Electronic Equipment in the Range of 9 kHz to 40 GHz"
ANSI C63.10:2013 (USA)	"American National Standard of Procedures for Compliance Testing of Unlicensed Wireless Devices"
FCC DA 00-705	"Filing and Measurement Guidelines for Frequency Hopping Spread Spectrum Systems"
CFR 47 2.1091/1093	"447498 D01 General RF Exposure Guidance v06: RF Exposure Procedures and Equipment Authorization Policies for Mobile and Portable Devices"
ISED Canada	"The Measurement of Occupied Bandwidth"
ISED Canada RSS-102	"Radio Frequency (RF) Exposure Compliance of Radiocommunication Apparatus (All Frequency Bands)"

1.2 Test Location and Equipment Used

Test Location The EUT was fully tested by **Willow Run Test Labs, LLC**, 8501 Beck Road, Building 2227, Belleville, Michigan 48111 USA. The Test Facility description and attenuation characteristics are on file with the FCC Laboratory, Columbia, Maryland (FCC Reg. No: 688478) and with ISED Canada, Ottawa, ON (File Ref. No: IC 8719A-1).

Test Equipment Pertinent test equipment used for measurements at this facility is listed in Table 1. The quality system employed at Willow Run Test Labs, LLC has been established to ensure all equipment has a clearly identifiable classification, calibration expiry date, and that all calibrations are traceable to the SI through NIST, other recognized national laboratories, accepted fundamental or natural physical constants, ratio type of calibration, or by comparison to consensus standards.

Table 1: Willow Run Test Labs, LLC Equipment List

Description	Manufacturer/Model	SN	Quality Num.	Last Cal By / Date Due
Spectrum Analyzer	Rhode-Schwarz / FSV30	101660	RSFSV30001	RS / Apr-2016
Dipole Set (20-1000 MHz)	EMCO / 3121C	9504-1121	DIPEMC001	Lib. Labs / Sep-2016
Quad Ridge Horn	ETS Lind. / 3164-04	00066988	HRNQR316401	Lib. Labs / Apr-2016
LS-Band Horn	JEF / NRL Std.	001	HRN15001	WRTL / Jul-2016
S-Band Horn	SA / NRL Std.	1854	HRNS001	WRTL / Jul-2016
C-Band Horn	SA / NRL Std.	-	HRNC001	WRTL / Jul-2016
Quad Ridge Horn	Singer / A6100	C35200	HQR2TO18S01	Lib. Labs / Apr-2016

2 Configuration and Identification of the Equipment Under Test

2.1 Description and Declarations

The EUT is a vehicular FHSS transceiver. The EUT is approximately 14 x 12 x 2 cm in dimension, and is depicted in Figure 1. It is powered by a 12.0 VDC vehicular power system. This device is a wireless FHSS communication device for control of vehicle remote start functionality. Table 2 outlines provider declared EUT specifications.

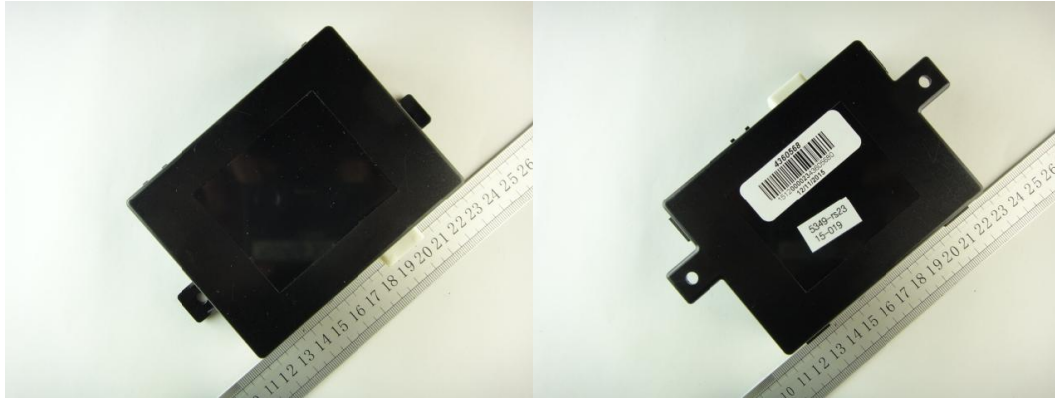

Figure 1: Photos of EUT.

Table 2: EUT Declarations.

General Declarations			
Equipment Type:	FHSS Transceiver	Country of Origin:	Taiwan
Nominal Supply:	12.0 VDC	Oper. Temp Range:	-20°C to +85°C
Frequency Range:	904 – 923.6 MHz	Antenna Dimension:	Not Declared
Antenna Type:	Integral or Ext. Dipole	Antenna Gain:	3.1 dBi (Int), 1.6 dBi (Ext)
Number of Channels:	50	Channel Spacing:	400 kHz
Alignment Range:	Not Declared	Type of Modulation:	GFSK
United States			
FCC ID Number:	ELVATRPG	Classification:	FHSS
Canada			
IC Number:	3671B-43605680	Classification:	Spread Spectrum

2.1.1 EUT Configuration

The EUT is configured for testing as depicted in Figure 2.

2.1.2 Modes of Operation

The EUT is capable of only a single operating mode, as an FHSS transceiver employing GFSK modulation over 50 channels from 904 MHz to 923.6 MHz with 400 kHz channel spacing. Only one antenna may be employed by the EUT at a time.

2.1.3 Variants

There is only a single variant of the EUT, as tested.

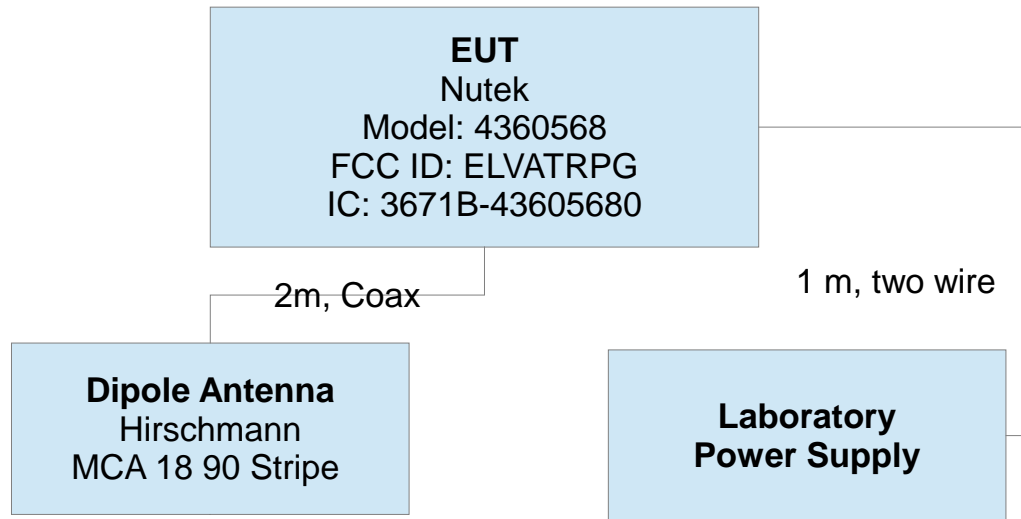

Figure 2: EUT Test Configuration Diagram.

2.1.4 Test Samples

Four samples in total were provided. Two software modified samples capable of CW transmission on the Low, Middle, and High channels for the internal and external antennas, a normal operating sample, and a normal sample modified with an RF coaxial cable attached to the internal antenna output were provided. A fifth unmodified sample was provided for photographs.

2.1.5 Functional Exerciser

Normal operating EUT functionality was verified by observation of transmitted signal.

2.1.6 Modifications Made

There were no modifications made to the EUT by this laboratory.

2.1.7 Production Intent

The EUT appears to be a production ready sample.

2.1.8 Declared Exemptions and Additional Product Notes

The EUT is permanently installed in a transportation vehicle. As such, digital emissions are exempt from US and Canadian digital emissions regulations (per FCC 15.103(a) and ISED correspondence on ICES-003). There is an external antenna port populated on the device to allow for a manufacturer supplied alternative antenna to be used in the vehicle. The transceiver will switch over the use the antenna populating the external port only if a proper DC return level is detected on the antenna port. This prevents use of any antenna other than the one supplied by the manufacturer from being used. The EUT employs a unique antenna connector (Hirose GT21T-1S-HU).

3 Emissions

3.1 General Test Procedures

3.1.1 Radiated Test Setup and Procedures

Radiated electromagnetic emissions from the EUT are first pre-scanned in our shielded anechoic chamber. Spectrum and modulation characteristics of all emissions are recorded. Instrumentation, including spectrum analyzers and other test equipment as detailed in Section 1.2 are employed. After indoor pre-scans, emission measurements are made on our outdoor 3-meter Open Area Test Site (OATS). If the EUT connects to auxiliary equipment and is table or floor standing, the configurations prescribed in relevant test standards are followed. Alternatively, a layout closest to normal use (as declared by the provider) is employed if the resulting emissions appear to be worst-case in such a configuration. See Figure 3. All intentionally radiating elements that are not fixed-mounted in use are placed on the test table lying flat, on their side, and on their end (3-axes) and the resulting worst case emissions are recorded. If the EUT is fixed-mounted in use, measurements are made with the device oriented in the manner consistent with installation and then emissions are recorded.

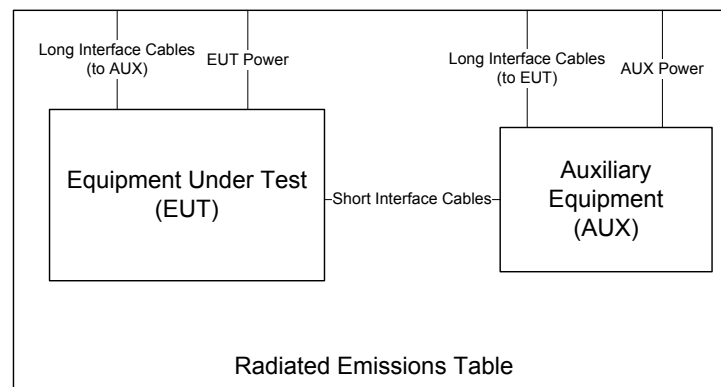

Figure 3: Radiated Emissions Diagram of the EUT.

If the EUT exhibits spurious emissions due to internal receiver circuitry, such emissions are measured with an appropriate carrier signal applied. For devices with intentional emissions below 30 MHz, a shielded loop antenna is used. It is placed at a 1 meter receive height. Emissions between 30 MHz and 1 GHz are measured using tuned dipoles and/or calibrated broadband antennas. For both horizontal and vertical polarizations, the test antenna is raised and lowered from 1 to 4 m in height until a maximum emission level is detected. The EUT is then rotated through 360° in azimuth until the highest emission is detected. The test antenna is then raised and lowered one last time from 1 to 4 m and the worst case value is recorded. Emissions above 1 GHz are characterized using standard gain horn antennas or calibrated broadband ridge-horn antennas on our OATS with a 4×5 m rectangle of AN-79 and/or H-4 absorber placed over the ground screen covering the OATS ground screen. Care is taken to ensure that test receiver resolution and video bandwidths meet the regulatory requirements, and that the emission bandwidth of the EUT is not reduced. Photographs of the test setup employed are depicted in Figure 4.

Where regulations allow for direct measurement of field strength, power values (dBm) measured on the test receiver / analyzer are converted to $\text{dB}\mu\text{V}/\text{m}$ at the regulatory distance, using

$$E_{dist} = 107 + P_R + K_A - K_G + K_E - C_F$$

where P_R is the power recorded on spectrum analyzer, in dBm, K_A is the test antenna factor in dB/m, K_G is the combined pre-amplifier gain and cable loss in dB, K_E is duty correction factor (when applicable) in dB, and C_F is a distance conversion (employed only if limits are specified at alternate distance) in dB. This field strength value is then compared with the regulatory limit. If effective isotropic radiated power (EIRP) is computed, it is computed as

$$EIRP(\text{dBm}) = E_{3m}(\text{dB}\mu\text{V}/\text{m}) - 95.2.$$

When presenting data at each frequency, the highest measured emission under all possible EUT orientations (3-axes) is reported.



Figure 4: Radiated Emissions Test Setup Photograph(s).

3.1.2 Conducted Emissions Test Setup and Procedures

Transmit Antenna Port Conducted Emissions At least one sample EUT supplied for testing was provided with a 50Ω antenna port. Conducted transmit chain emissions measurements (where applicable) are made by connecting the EUT antenna port directly to the test receiver port. Photographs of the test setup employed are depicted in Figure 5.



Figure 5: Conducted RF Test Setup Photograph(s).

Vehicle Power Conducted Spurious The EUT is not subject to power line conducted emissions regulations as it is powered solely by the vehicle power system for use in said motor vehicle.

3.1.3 Power Supply Variation

Tests at extreme supply voltages are made if required by the the procedures specified in the test standard, and results of this testing are detailed in this report.

3.1.4 Thermal Variation

Tests at extreme temperatures are made if required by the procedures specified in the test standard, and results of this testing are detailed in this report. The provider has declared that the EUT is designed for operation over the temperature range -20°C to $+85^{\circ}\text{C}$. Before any temperature measurements are made, the equipment is allowed to reach a thermal balance in the test chamber, temperature and humidity are recorded, and thermal balance is verified via a thermocouple-based probe.

3.2 Intentional Emissions

3.2.1 Duty and Transmission Cycle, Pulsed Operation

The details and results of testing the EUT for pulsed operation are summarized in Table 3.

Table 3: Pulsed Emission Characteristics (Duty Cycle).

Frequency Range 914 MHz 901MHz to 929 MHz	Det Pk Pk	IFBW 100 kHz 28 MHz	VBW 300 kHz 28 MHz	Test Date: 15-Mar-16 Test Engineer: Joseph Brunett EUT Nutek IVU – Small Meas. Distance: Conducted
--	------------------------	----------------------------------	---------------------------------	---

Pulsed Operation / Duty Cycle								
Transmit Mode	Symbol Rate (Msym/s)	Mod. / Data Rate (Mbps)	Voltage (V)	Observation Freq (MHz)	Tx Cycle Time* (ms)	On-Time** (ms)	Duty Cycle (%)	Single Channel Duty Correction (dB)
Hopping	-	GFSK	12.0	914.0	>100	62.5	62.5	4.1
Transmit Mode	Symbol Rate (Msym/s)	Mod. / Data Rate (Mbps)	Voltage (V)	Observation Freq (MHz)	Exposure Window (min)	On-Time*** (s)	Duty Cycle (%)	Exposure Duty Correction (dB)
Hopping	-	GFSK	12.0	Full Band	6.0	7.2	2.000	17.0

* For a single remote button press, the EUT's response hopping transmission only traverses each channel twice, thus only two frames are observed.

** Worst case observed on-time at a single channel (same on average for all channels in pseudo-random FHSS protocol).

*** Worst case observed on-time over all channels upon single remote activation (button press).

Equipment Used: RSFSV30001

3.2.2 Hopping Channel Dwell Time

The average time of occupancy on any hopping channel must not be greater than 0.4 seconds within a 20 second period for FHSS device with 50 operating channels. For this test, the EUT was set for data transmission with hopping enabled. Results of this testing are depicted in Table 4. Plots showing example measurements made

Table 4: Hopping Channel Dwell Time.

Frequency Range 25 MHz f 1 000 MHz f > 1 000 MHz	Det Pk/QPk Pk	IF Bandwidth 120 kHz 1 MHz	Video Bandwidth 300 kHz 3 MHz	Test Date: 15-Mar-16 Test Engineer: Joseph Brunett EUT: Nutek IVU – Small Meas. Distance: Conducted
---	----------------------------	---	--	--

Dwell Time								
Mode	Frequency (MHz)	# Bursts #	Observation Time (sec)	Window (sec)	Active Time (sec)	Total On Time** (sec)	Limit (sec)	Pass/Fail
Hopping	904.0	1	10.0	20.0	0.1250	0.2500	<0.4	Pass
	914.0	1	10.0	20.0	0.1250	0.2500	<0.4	Pass
	923.6	1	10.0	20.0	0.1250	0.2500	<0.4	Pass

* Dwell Time Observed with EUT automatically activated hopping.

** Only two frames occur per channel in the hopping sequence for a single automatic activation in a 10 second window.

Equipment Used: RSFSV30001

to obtain these values are provided in Figure 6.

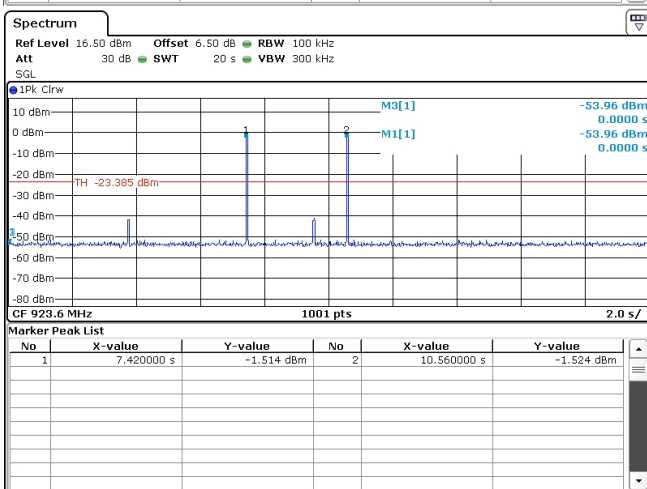
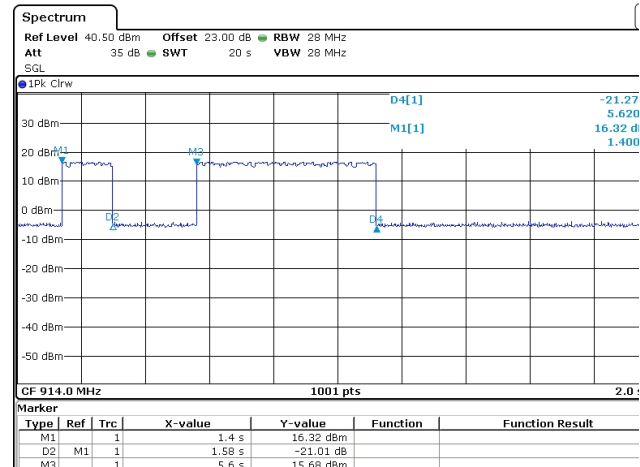
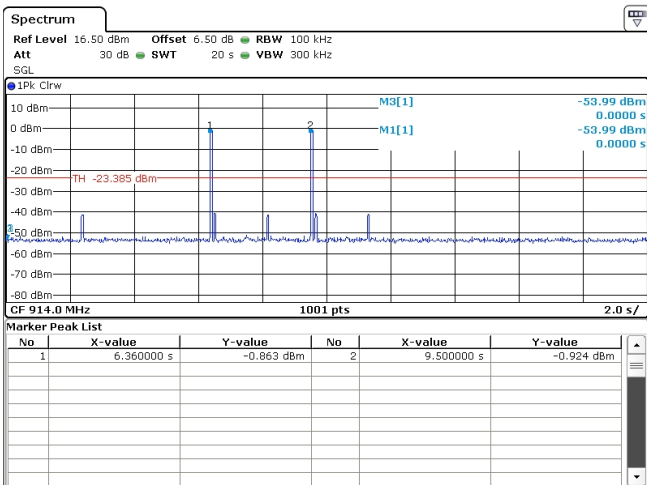
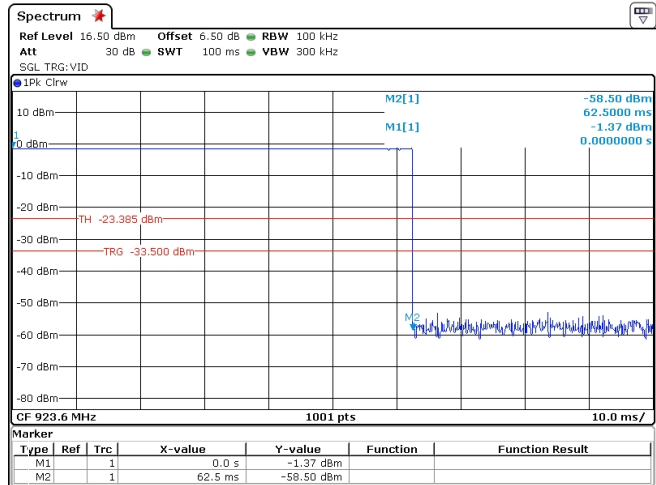
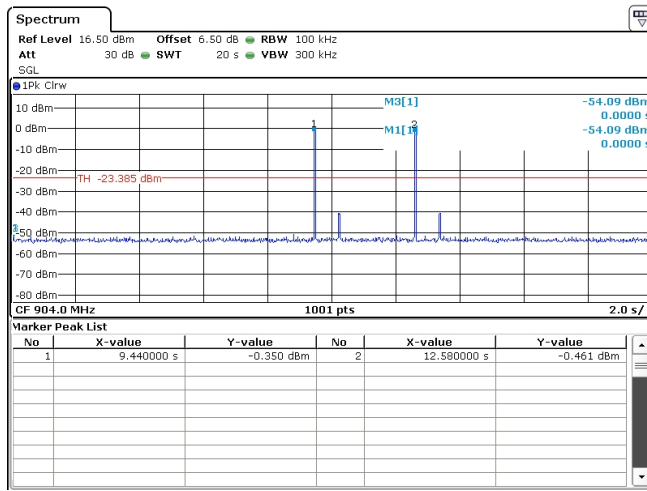

Figure 6: Example Plots of Duty Cycle and Channel Dwell Time.

3.2.3 Channel Bandwidth

For this test, the EUT was set continuous data transmission (hopping disabled) in each modulation. The 20-dB bandwidth as well as 99% emission bandwidth were measured for the low, middle, and high channels. Results of these measurements are shown in Table 5. Plots showing example measurements employed to obtain this data are provided in Figure 8.

Table 5: Intentional Emission Bandwidth.

Frequency Range	Det	IFBW	VBW	Test Date:	03/15/16
f > 1 000 MHz	Pk	30 kHz	100 kHz	Test Engineer:	Joseph Brunett
f > 1 000 MHz	Pk	30 kHz	100 kHz	EUT	Nutek IVU – Small
				Meas. Distance:	Conducted

Occupied Bandwidth									
Transmit Mode	Symbol Rate (Msym/s)	Data Rate (Mbps)	Voltage (V)	Oper. Freq (MHz)	6 dB BW (kHz)	6 dB BW Limit (MHz)	99% OBW (kHz)	20 dB BW (kHz)	Comments
GFSK	-	-	3.0	904.0	48.45	-	88.412	92.41	
				914.0	48.45	-	86.913	91.41	
				923.6	47.45	-	87.413	90.91	

Equipment Used: RSFSV30001

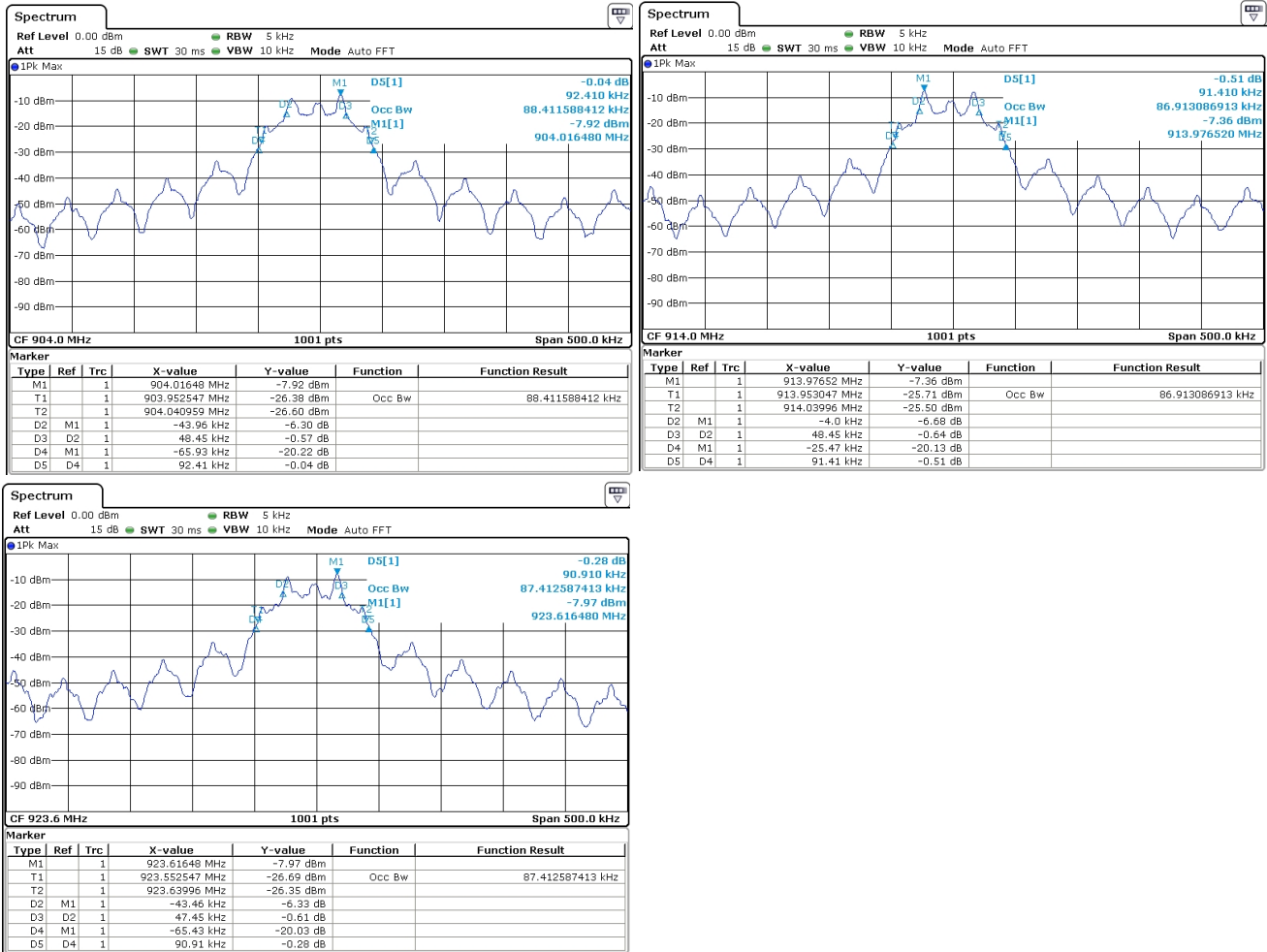

Figure 7: Intentional Emission Bandwidth.

3.2.4 Number of Hopping Channels

For this test, the EUT was enabled for data transmission with hopping. The number of channels measured is reported here in Table 6.

Table 6: Measured Number of Hopping Channels.

Frequency Range	Det	IF Bandwidth	Video Bandwidth	Test Date:	15-Mar-16
25 MHz f 1 000 MHz	Pk/QPk	100/120 kHz	300 kHz	Test Engineer:	Joseph Brunett
f > 1 000 MHz	Pk	100 kHz	3 MHz	EUT:	Nutek IVU – Small
				Meas. Distance:	Conducted

Number of Hopping Channels						
Mode	Start Frequency (MHz)	Stop Frequency (MHz)	Number of Channels Observed (#)	Total Number (#)	Limit (#)	Pass/Fail
Hopping	902.0	928.0	50	50	50.0	Pass

Equipment Used: RSFSV30001

3.2.5 Channel Separation

For this test, the EUT was enabled for data transmission with hopping. The Carrier Separation was measured for low, mid, and high channels. Results of these measurements are shown in Table 7.

Table 7: Measured Channel Separation.

Frequency Range	Det	IF Bandwidth	Video Bandwidth	Test Date:	15-Mar-16
25 MHz f 1 000 MHz	Pk/QPk	100/120 kHz	300 kHz	Test Engineer:	Joseph Brunett
f > 1 000 MHz	Pk	100 kHz	3 MHz	EUT:	Nutek IVU – Small
				Meas. Distance:	Conducted

Hopping Frequency Separation					
Mod	Low Channel (MHz)	High Channel (MHz)	Separation (kHz)	Min. Separation Limit (kHz)	Pass/Fail
GFSK	904.0	904.4	398.000	92.41	Pass
	914.0	914.4	403.500	92.41	Pass
	923.2	923.6	400.000	92.41	Pass

* Channel Separation Observed with the Device hopping over all available channels.

Equipment Used: RSFSV30001

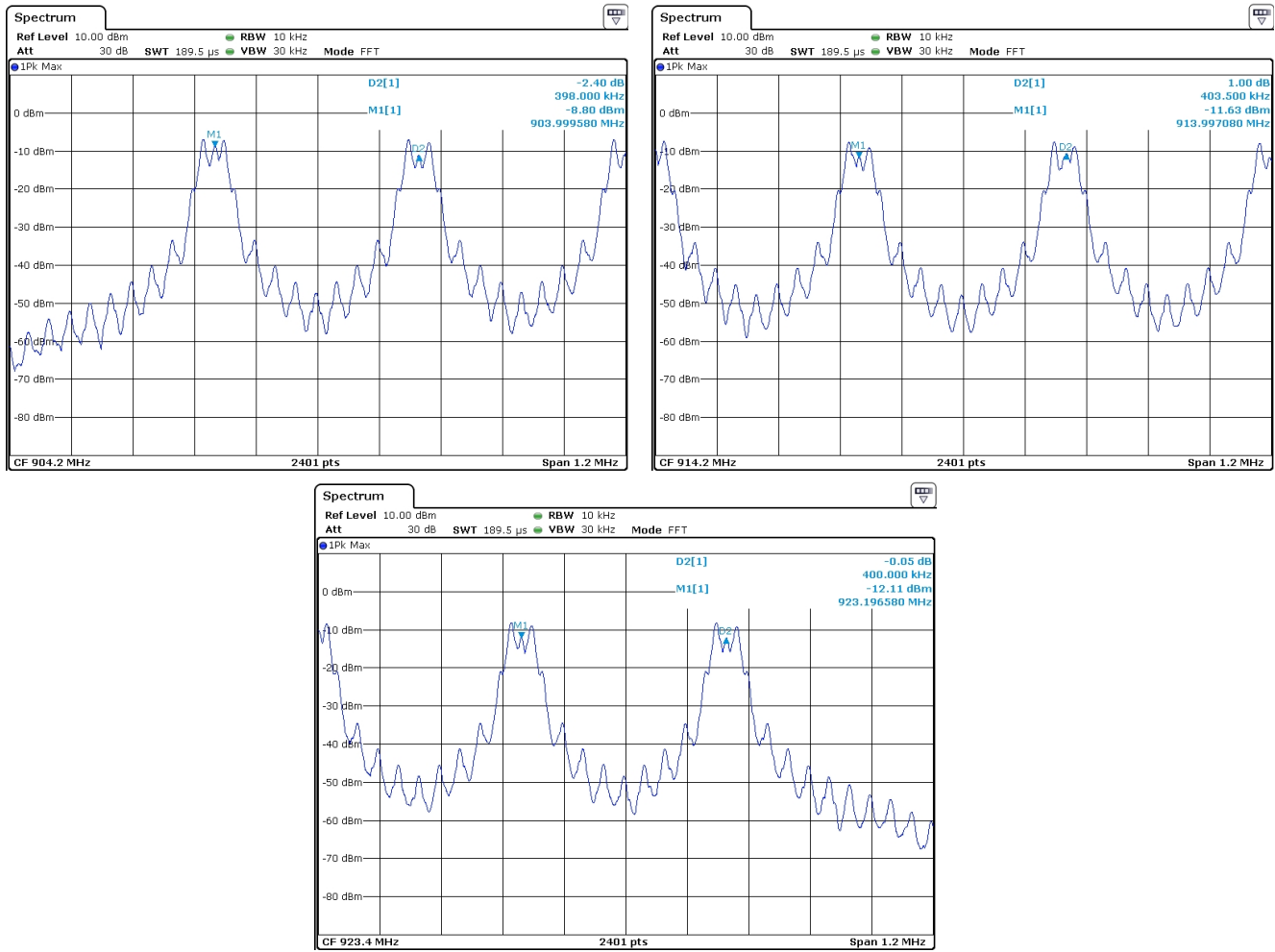

Figure 8: Measured Channel Separation.

3.2.6 Effective Isotropic Radiated Power

The EUT’s radiated power is computed from antenna port conducted power measurements and the gain of the EUT antenna(s). Where the EUT is not sold with an antenna connector, a modified product has been provided including such. Peak conducted output power was measured directly from the EUT at the port where the antenna attaches. The test receiver bandwidth was set to be greater than the measured emission bandwidth of the EUT to capture the true peak. Antenna gain is either provided directly by the antenna manufacturer or measured by comparison between calculated EIRP and conducted output power. Table 8 details the results of these measurements. Plots showing conducted measurements made are depicted in Figure 9.

Table 8: Radiated Power Results.

Frequency Range	Det	IF Bandwidth	Video Bandwidth	Test Date:	17-Feb-16
25 MHz f 1 000 MHz	Pk/QPk	120 kHz	300 kHz	Test Engineer:	Joseph Brunett
f > 1 000 MHz	Pk/Avg	3 MHz	3 MHz	EUT:	Nutek IVU – Small
Equipment Used: HRN15001, RSFSV30001				Meas. Distance:	3m

FCC/IC

#	Antenna	Channel	Freq. MHz	Ant. Used	Ant. Pol.	Pr (Pk)** (dBm)	Ka (dB/m)	Kg (dB)	EIRP (Pk) (dBm)	Pout* (Pk) (dBm)	Ant Gain (dBi)	EIRP (Avg) Limit (dBm)	Pass (dB)
1	Internal	1	904.0	Dipole	H	7.1	28.3	28.7	18.6	16.3	2.3	30.0	11.4
2		1	904.0	Dipole	V	6.3	28.3	28.7	17.9	16.3	1.6	30.0	12.1
3		25	914.0	Dipole	H	7.2	28.5	28.6	18.9	16.2	2.7	30.0	11.1
4		25	914.0	Dipole	V	6.0	28.5	28.6	17.7	16.2	1.5	30.0	12.3
5		50	923.6	Dipole	H	6.9	28.6	28.5	18.8	16.2	2.6	30.0	11.2
6		50	923.6	Dipole	V	5.1	28.6	28.5	17.0	16.2	0.8	30.0	13.0
7													
8	External	1	904.0	Dipole	H	5.1	28.3	28.7	16.6	16.3	0.3	30.0	13.4
9		1	904.0	Dipole	V	4.6	28.3	28.7	16.2	16.3	-0.1	30.0	13.8
10		25	914.0	Dipole	H	5.4	28.5	28.6	17.1	16.1	1.0	30.0	12.9
11		25	914.0	Dipole	V	5.0	28.5	28.6	16.7	16.1	0.6	30.0	13.3
12		50	923.6	Dipole	H	5.8	28.6	28.5	17.7	16.1	1.6	30.0	12.3
13		50	923.6	Dipole	V	4.1	28.6	28.5	16.0	16.1	-0.1	30.0	14.0
14													
#	Antenna	Channel	Freq. MHz	Supply Voltage	Ant. Pol.	Pout* (Pk) (dBm)							
8	Internal	25	914.0	14.0	H/V	7.1							
9			914.0	12.0	H/V	7.2							
10			914.0	10.0	H/V	7.2							

* Measured conducted from the radio using conducted test sample.

** Measured radiated at 3 meter distance. Peak power measured with IFBW > OBW

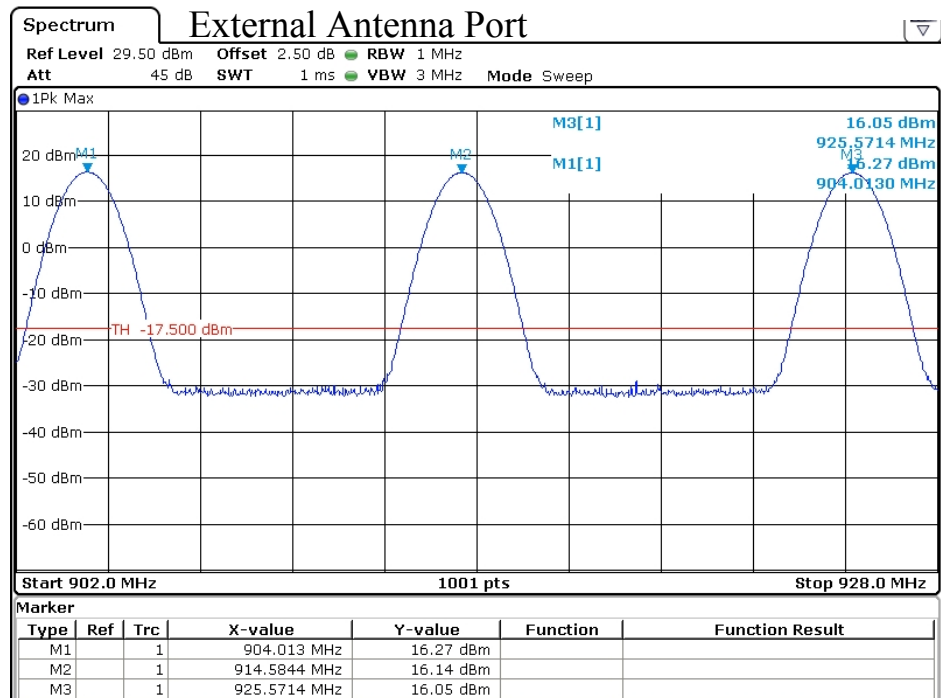
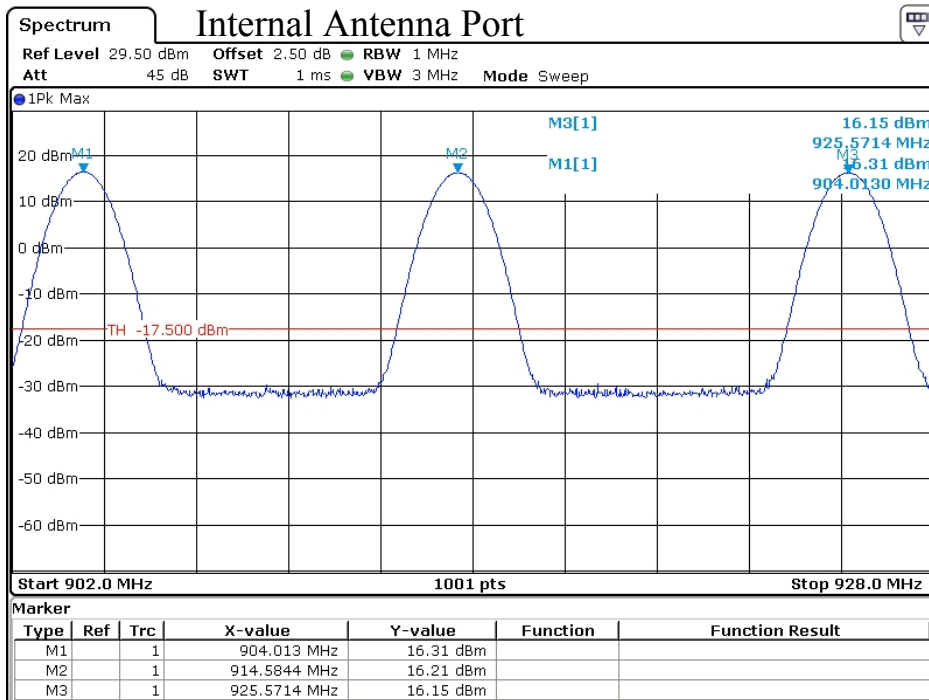

Figure 9: Conducted RF Power Plots

3.2.7 Exposure and Potential Health Hazard

To demonstrate compliance with with regulations that place limitations on human electromagnetic field exposure for both the general public and for workers, we compute EIRP from measured emission data. These levels are compared with limits placed by the directives and recommendations detailed in Section 1.1. Table 9 details the results of these computations.

Table 9: Electromagnetic Field Exposure.

USA REF: 2.1091/1093, 447498 D01 General RF Exposure Guidance v06	Test Date: 17-Feb-16
IC REF: RSS-102 Issue 5	Test Engineer: Joseph Brunett
Sep. Distance: >20cm	EUT: Nutek IVU – Small
	EUT Mode: Hopping
	Meas. Distance: 3 meters

Freq. MHz	Pout* (Pk) dBm	EIRP* (Pk) dBm	Worst Case Source Based Time Averaged Po/EIRP(Pk)** mW	Power Density S @ 20cm mW/cm^2	Canada	USA
					Worst Case Source Based Time Averaged Threshold (Avg) mW	Power Density Limit S @ 20cm mW/cm^2
904.0	16.3	18.6	72.0	0.0143	1372.5	1.0
914.0	16.2	18.9	77.5	0.0154	1382.9	1.0
923.6	16.2	18.8	75.9	0.0151	1392.8	1.0

*As Measured / Computed from highest fundamental emission, see fundamental emission section of this report.

**Only RMS level is required, RMS/6min << Pk, Peak emission employed to demonstrate compliance.

3.3 Unintentional Emissions

3.3.1 Transmit Chain Spurious Emissions

The results for the measurement of transmit chain spurious emissions at the nominal voltage and temperature are provided in Table 10. Measurements are performed to 10 times the highest fundamental operating frequency.

Table 10: Transmit Chain Spurious Emissions.

Frequency Range 25 MHz f 1 000 MHz
f > 1 000 MHz

Det Pk/QPk
Pk/Avg

IF Bandwidth 120 kHz
1 MHz

Video Bandwidth 300 kHz
3 MHz

Test Date: 17-Feb-16
Test Engineer: Joseph Brunett
EUT: Nutek IVU – Small
Mode: Hopping / CW
Meas. Distance: 3m

Equipment Used: RSFSV30001

FCC/IC													
#	Freq. Start MHz	Freq. Stop MHz	Ant. Used	Ant. Pol.	Pr (Pk/Avg) dBm	Pr (Qpk/Avg)* dBm	Ka dB/m	Kg dB	E3(Pk) dBµV/m	E3(Avg) dBµV/m	E3 Avg Lim dBµV/m	Pass dB	Comments
1 External Antenna													
2 Fundamental Band Edge (Low Side)													
3	902.0	902.0	Dipole	H/V	-56.9	-64.8	28.3	28.7	49.7	41.8	46.0	4.2	hopping
4 Fundamental Band Edge (High Side)													
5	928.0	928.0	Dipole	H/V	-59.9	-66.2	28.6	28.4	47.3	41.0	46.0	5.0	hopping
6 Harmonic / Spurious Emissions													
7	1808.0	1808.0	HRNLS	H/V	-85.2	-89.3	20.9	-0.2	42.9	38.8	54.0	15.2	
8	1828.0	1828.0	HRNLS	H/V	-87.2	-91.3	20.8	-0.2	40.9	36.8	54.0	17.2	
9	1847.2	1847.2	HRNLS	H/V	-88.9	-93.0	20.8	-0.2	39.1	35.0	54.0	19.0	
10	2712.0	2712.0	HRNS	H/V	-80.1	-84.2	21.6	-0.3	48.8	44.7	54.0	9.3	
11	2742.0	2742.0	HRNS	H/V	-76.9	-81.0	21.6	-0.3	52.0	47.9	54.0	6.1	
12	2770.8	2770.8	HRNS	H/V	-76.8	-80.9	21.6	-0.3	52.1	48.0	54.0	6.0	
13	3616.0	3616.0	HRNS	H/V	-85.2	-89.3	22.3	-0.4	44.4	40.3	54.0	13.7	
14	3656.0	3656.0	HRNS	H/V	-83.5	-87.6	22.3	-0.4	46.2	42.1	54.0	11.9	
15	3694.4	3694.4	HRNS	H/V	-83.9	-88.0	22.3	-0.4	45.8	41.7	54.0	12.3	
16	4000.0	6000.0	HQR2TO18S01	H/V	-91.3	-95.4	33.6	-0.6	49.9	45.8	54.0	8.2	
17	5424.0	5424.0	HRNC	H/V	-78.9	-83.0	24.7	-0.5	53.4	49.3	53.0	3.7	
18	6000.0	8400.0	HQR2TO18S01	H/V	-98.2	-102.3	32.8	-0.8	42.4	38.3	54.0	15.7	
19	8400.0	12500.0	HQR2TO18S01	H/V	-98.3	-102.4	34.3	-1.1	44.1	40.0	54.0	14.0	
20													
21													
22 Internal Antenna													
23 Fundamental Band Edge (Low Side)													
24	902.0	902.0	Dipole	H/V	-62.3	-67.9	28.3	28.7	44.3	38.7	46.0	7.3	
25 Fundamental Band Edge (High Side)													
26	928.0	928.0	Dipole	H/V	-58.7	-65.3	28.6	28.4	48.5	41.9	46.0	4.1	
27 Harmonic / Spurious Emissions													
28	1808.0	1808.0	HRNLS	H/V	-79.2	-83.3	20.9	-0.2	48.9	44.8	54.0	9.2	
29	1828.0	1828.0	HRNLS	H/V	-78.7	-82.8	20.8	-0.2	49.4	45.3	54.0	8.7	
30	1847.2	1847.2	HRNLS	H/V	-80.1	-84.2	20.8	-0.2	47.9	43.8	54.0	10.2	
31	2712.0	2712.0	HRNS	H/V	-85.8	-89.9	21.6	-0.3	43.1	39.0	54.0	15.0	
32	2742.0	2742.0	HRNS	H/V	-84.7	-88.8	21.6	-0.3	44.2	40.1	54.0	13.9	
33	2770.8	2770.8	HRNS	H/V	-85.2	-89.3	21.6	-0.3	43.7	39.6	54.0	14.4	
34	3616.0	3616.0	HRNS	H/V	-75.2	-79.3	22.3	-0.4	54.4	50.3	54.0	3.7	
35	3656.0	3656.0	HRNS	H/V	-79.3	-83.4	22.3	-0.4	50.4	46.3	54.0	7.7	
36	3694.4	3694.4	HRNS	H/V	-80.1	-84.2	22.3	-0.4	49.6	45.5	54.0	8.5	
37	4000.0	6000.0	HQR2TO18S01	H/V	-88.9	-93.0	33.6	-0.6	52.3	48.2	54.0	5.8	
38	5424.0	5424.0	HRNC	H/V	-77.2	-81.3	24.7	-0.5	55.1	51.0	54.0	3.0	
39	6000.0	8400.0	HQR2TO18S01	H/V	-95.2	-99.3	32.8	-0.8	45.4	41.3	54.0	12.7	
40	8400.0	12500.0	HQR2TO18S01	H/V	-94.2	-98.3	34.3	-1.1	48.2	44.1	54.0	9.9	
41													

*Avg computed from Peak/Avg by duty cycle.

3.3.2 Relative Transmit Chain Spurious Emissions

The results for the measurement of transmit chain spurious emissions relative to the fundamental in a 100 kHz receiver bandwidth (at the nominal voltage and temperature) are provided in Figure 10 below.

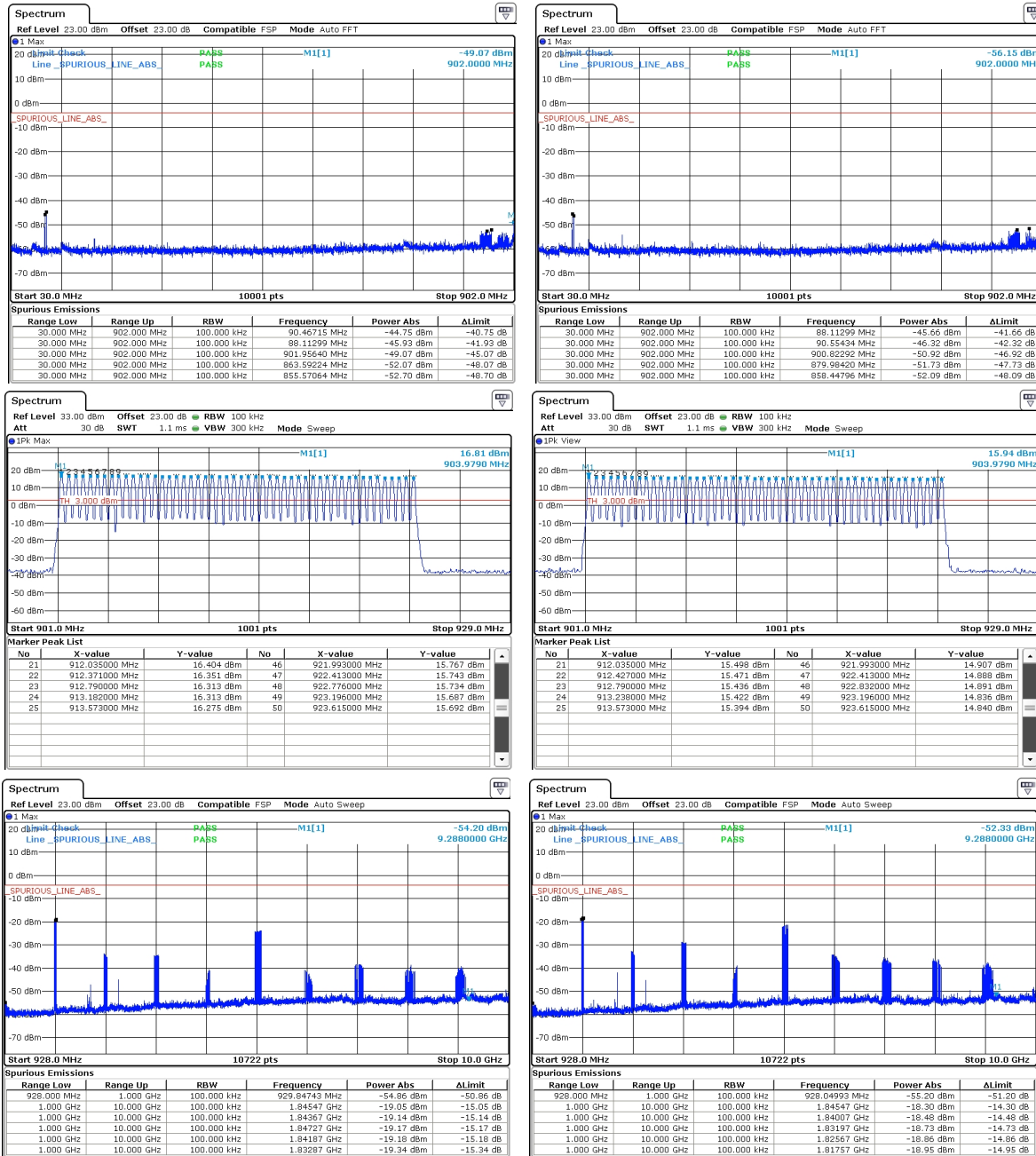

Figure 10: Conducted Transmitter Emissions Measured.

4 Measurement Uncertainty

The maximum values of measurement uncertainty for the laboratory test equipment and facilities associated with each test are given in the table below. This uncertainty is computed for a 95.45% confidence level based on a coverage factor of $k = 2$.

Table 11: Measurement Uncertainty.

Measured Parameter	Measurement Uncertainty [†]
Radio Frequency	$\pm(f_{Mkr}/10^7 + RBW/10 + (SPN/(PTS - 1))/2 + 1 \text{ Hz})$
Conducted Emm. Amplitude	$\pm 1.8 \text{ dB}$
Radiated Emm. Amplitude (30 – 200 MHz)	$\pm 2.7 \text{ dB}$
Radiated Emm. Amplitude (200 – 1000 MHz)	$\pm 2.5 \text{ dB}$
Radiated Emm. Amplitude ($f > 1000 \text{ MHz}$)	$\pm 3.7 \text{ dB}$
DC and Low Frequency Voltages	$\pm 2\%$
Temperature	$\pm 0.5^\circ\text{C}$
Humidity	$\pm 5\%$

[†]Ref: CISPR 16-4-2:2011+A1:2014