

CFR 47 FCC Part 15.247

TEST REPORT

Product : **Transmitter**

Trade Name : N/A

Model Number : SS92P

FCC ID : ELVATRKA

Prepared for

Nutek Corporation

NO.167, Lane 235, Bauchiau Rd., Shindian City, Taipei County 23145, Taiwan

TEL. : +886 2 2918 9478

FAX. : +886 2 2917 9069

Prepared by

Interocean EMC Technology Corp.

244 No.5-2, Lin 1, Tin-Fu Tsun, Lin-Kou Hsiang,
Taipei County, Taiwan, R.O.C.

TEL.: +886 2 2600 6861

FAX.: +886 2 2600 6859

Remark :

The test report consists of **53** pages in total. It shall not be reproduced except in full, without the written approval of IETC. This document may be altered or revised by IETC only, and shall be noted in the revision section of the document.

The test results in the report only to the tested sample.

Table of Contents

1	General Information	5
1.1	Description of Equipment Under Test	5
1.2	Table for Carrier Frequencies	6
1.3	Test Facility	7
1.4	Test Equipment	8
1.5	Summary of Measurement	9
1.6	Justification	10
2	Test specifications	11
2.1	Test standard	11
2.2	Operation mode	11
3	20dB Bandwidth test	12
3.1	Limit	12
3.2	Configuration of Measurement	12
3.3	Test Procedure	12
3.4	Test Result	12
4	Carrier Frequency Separation test	15
4.1	Limit	15
4.2	Configuration of Measurement	15
4.3	Test Procedure	15
4.4	Test Result	15
5	Number of hopping frequencies test	17
5.1	Configuration of Measurement	17
5.2	Test Procedure	17
5.3	Test Result	17
6	Time of Occupancy (dwell time) test	19
6.1	Limit	19
6.2	Configuration of Measurement	19
6.3	Test Procedure	19
6.4	Test Result	19
7	Maximum Output Power test	21
7.1	Limit	21
7.2	Configuration of Measurement	21
7.3	Test Procedure	21
7.4	Test Result	21
8	RF Conducted spurious emission	25
8.1	Limit	25
8.2	Configuration of Measurement	25
8.3	Test Procedure	25
8.4	Test Result	25

9	RF Radiated spurious emission test	31
9.1	Limit	31
9.2	Configuration of Measurement	31
9.3	Test Procedure	32
9.4	Test Result	32
10	AC Power Line Conducted Emission test	37
10.1	Limits	37
10.2	Configuration of Measurement	37
10.3	Test Procedures	37
10.4	Test Result	37
11	Photographs of Test	44
11.1	Power Line Conducted Emission Measurement	44
11.2	Radiated Emission Measurement	45
12	Photographs of EUT	47

Statement of Compliance

Applicant: Nutek Corporation

Manufacturer: Nutek Corporation

Product: Transmitter

Model No.: SS92P

Tested Power Supply: 120Vac, 60Hz

Date of Final Test: Apr. 13, 2011

Revision of Report: Rev. 00

Configuration of Measurements and Standards Used :

FCC Rules and Regulations Part 15 Subpart C

I HEREBY CERTIFY THAT: The data shown in this report were made in accordance with the procedures given in ANSI C63.4, and the energy emitted by the device was founded to be within the limits applicable. I assume full responsibility for accuracy and completeness of these data.

Note: 1. The result of the testing report relate only to the item tested.

2. The testing report shall not be reproduced expect in full, without the written approval of IETC

Report Issued: 2011/04/26

Project Engineer: 
Elli Chang

Approved: 
Jerry Liu

1 General Information

1.1 Description of Equipment Under Test

Product	: Transmitter
Model Number	: SS92P
Applicant	: Nutek Corporation NO.167, Lane 235, Bauchiau Rd., Shindian City, Taipei County 23145, Taiwan
Manufacturer	: Nutek Corporation NO.167, Lane 235, Bauchiau Rd., Shindian City, Taipei County 23145, Taiwan
Power Supply	: AC/DC Adaptor Model No.: YL20W-050A-050 Input: 100-240Vac, 50/60Hz, 0.2A Output: 5Vdc, 0.5A Power Cable: Non-shielded, Un-detachable, 1.8m, without core
Operating Frequency	: 909.5MHz ~ 919.024MHz
Channel Number	: 25 channels
Type of Modulation	: FSK
Antenna Description	: This device uses Helix antenna. The antenna is integral to the device, thereby meeting the requirement of FCC 15.203.
Date of Test	: Mar. 21~Apr. 13, 2011
Additional Description	: 1) The Model Number " SS92P " is representative selected in the test and included in this report. 2) For more detail specification about EUT, please refer to the user's manual.

1.2 Table for Carrier Frequencies

Channel	Frequency (MHz)	Channel	Frequency (MHz)
CH0	909.5000	CH13	915.1110
CH1	909.9570	CH14	915.4590
CH2	910.2860	CH15	915.8100
CH3	910.6380	CH16	916.1900
CH4	911.0000	CH17	916.5280
CH5	911.3600	CH18	916.8890
CH6	912.6270	CH19	917.2310
CH7	912.9800	CH20	917.5810
CH8	913.3620	CH21	917.9430
CH9	913.7140	CH22	918.3030
CH10	914.0650	CH23	918.6670
CH11	914.4000	CH24	919.0240
CH12	914.7430		

1.3 Test Facility

- Site Description** : ☑Conduction 2 ☑OATS 2 ☑RF Test Room
- Name of Firm** : Interocean EMC Technology Corp.
- Company web** : <http://www.ietc.com.tw>
- Site 1, 2, 3 Location** : No.5-2, Lin 1, Tin-Fu Tsun, Lin-Kou Hsiang,
Taipei County, Taiwan, R.O.C.
- Site Filing** :
- Federal Communication Commissions – USA
Registration No.: 96399 (OATS 1 & 2)
Registration No.: 518958 (OATS 3)
Designation No.: TW1020
 - Voluntary Control Council for Interference by Information
Technology Equipment (VCCI) – Japan
Member No.: 1349
Registration No. (Conducted Room): C-1094
Registration No. (Conducted Room): T-1562
Registration No. (OATS 1): R-1040; G-274
Registration No. (OATS 2): R-1041
 - Industry Canada (IC)
OUR FILE: 46405-4437 Submission: 145171
Registration No. (OATS 1): Site# 4437A-1
Registration No. (OATS 2): Site# 4437A-2
Registration No. (OATS 3): Site# 4437A-3
- Site Accreditation** :
- Bureau of Standards and Metrology and Inspection (BSMI) –
Taiwan, R.O.C.
Accreditation No.:
SL2-IN-E-0026 for CNS13438 / CISPR22
SL2-R1-E-0026 for CNS13439 / CISPR13
SL2-R2-E-0026 for CNS13439 / CISPR13
SL2-A1-E-0026 for CNS13783-1 / CISPR14-1
SL2-L1-E-0026 for CNS 14115 / CISPR 15
 - Taiwan Accreditation Foundation (TAF)
Accrditation No.: 1113
 - TÜV NORD
Certificate No: TNTW0801R-03



1.4 Test Equipment

Instrument	Manufacturer	Model	Serial No.	Next Cal. Date
Spectrum Analyzer	R&S	FSP30	100002	2012/01/02
Spectrum Analyzer	R&S	FSP40	100478	2011/04/20
Preamplifier	Agilent	8449B	3008A01434	2011/04/20
Preamplifier	Agilent	83050A	3950A00225	2012/09/07
Preamplifier	Schwarzbeck	CA30100	2	2011/10/28
Horn Antenna	COM-POWER	AH-118	10081	2012/05/19
Horn Antenna	Schwarzbeck	BBHA 9120	9120D-583	2012/02/09
Horn Antenna	Schwarzbeck	BBHA 9170	213	2012/07/19
Wide Bandwidth Sensor	Anritsu	MA2491A	728133	2011/11/13
Power Meter	Anritsu	ML2495A	736010	2011/11/13
Temp & Humidity chamber	GIAN FORCE	GTH-150-40-2P-U	MAA0305-012	2011/05/07
EMI Test Receiver	R&S	ESCS30	100134	2011/07/20
RF Cable	HARBOUR	RG-58/U	CBL40	2011/11/10
L.I.S.N.	Schaffner	MN2050D	1597	2011/06/10
L.I.S.N.	R&S	ESH3-Z5	829996/016	2012/01/02
EMI Test Receiver	R&S	ESCI	100836	2011/06/09
Spectrum Analyzer	Advantest	R3162	131201395	2011/04/25
Biconical Antenna	Schwarzbeck	VHA 9103	2484	2011/10/08
Log Antenna	Schwarzbeck	UHALP 9108	A 0765	2011/10/08
Pre-Amplifier	Schwarzbeck	CPA9231A	3349	2011/08/03
RF Cable	IETC	8DFB	CBL14	2011/07/14

Note: The above equipments are within the valid calibration period.

1.5 Summary of Measurement

Report Clause	Test Parameter	Reference Document CFR47 Part15	Results
3	20dB Bandwidth test	§15.247(a)(1)	Pass
4	Carrier Frequency Separation test	§15.247(a)(1)	Pass
5	Number of hopping frequencies test	§15.247(a)(1)	Pass
6	Time of Occupancy (dwell time) test	§15.247(a)(1)	Pass
7	Maximum Peak output power test	§15.247(b)	Pass
8	RF Conducted spurious emission	§15.247(c)	Pass
9	RF Radiated spurious emission test	§15.205, 15.209	Pass
	Emission on the Band Edge test	§15.247(d)	Not Applicable
10	AC Power Line Conducted Emission test	§15.247(b)	Pass

1.6 Justification

The test of radiated measurements according to FCC Part15 Section 15.33(a) had been conducted and the field strength of the frequency band were all arrive limit requirement, thus we evaluate the EUT pass the specified test.

2 Test specifications

2.1 Test standard

The EUT was performed according to FCC Part 15 Subpart C Section 15.247 procedure and setup followed by ANSI C63.4, 2003 requirements.

2.2 Operation mode

By preliminary testing and verifying three axis (X, Y and Z) position of EUT transmitted status, it was found that "Z axis" position was the worst, then the final test was executed the worst condition and test data were recorded in this report

The EUT was operated in continuous transmission mode during all of the tests.



X axis mode



Y axis mode



Z axis mode

3 20dB Bandwidth test

3.1 Limit

No regulation limit, for reference purpose.

3.2 Configuration of Measurement

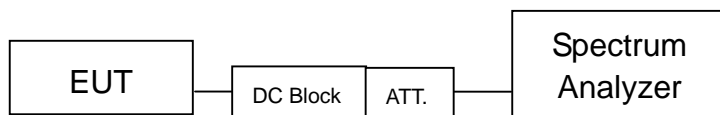

3.3 Test Procedure

The EUT was setup to ANSI C63.4, 2003; tested to FHSS test procedure of FCC Public Notice DA 00-705 for compliance to FCC 47CFR 15.247 requirements.

The 20dB bandwidth per FCC §15.247(a)(1) was measured using a 50 ohm spectrum analyzer with the resolutions bandwidth set at 100 kHz, the video bandwidth \geq RBW, and the SPAN may equal to approximately 2 to 3 time the 20dB bandwidth.

3.4 Test Result

PASS.

The final test data is shown as following pages.

20dB bandwidth

Modulation	CH No.	Freq. (MHz)	20dB Bandwidth (MHz)	Limit (kHz)
FSK	0	909.5	276.00	250 - 500
	12	914.743	254.00	250 - 500
	24	919.024	258.00	250 - 500

CH0 909.5MHz

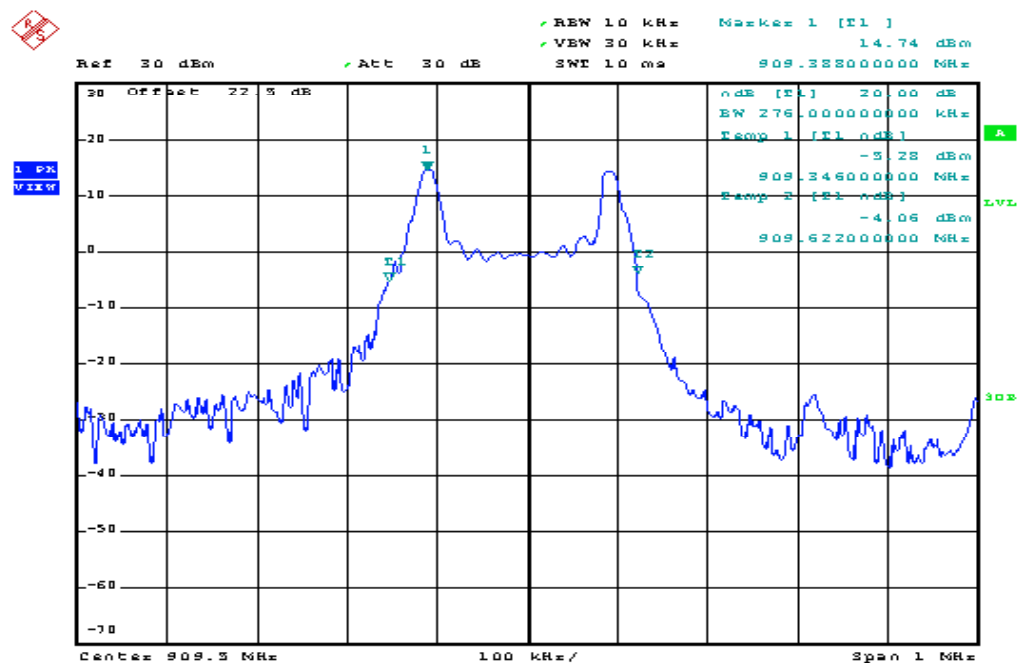

CH12 914.743MHz

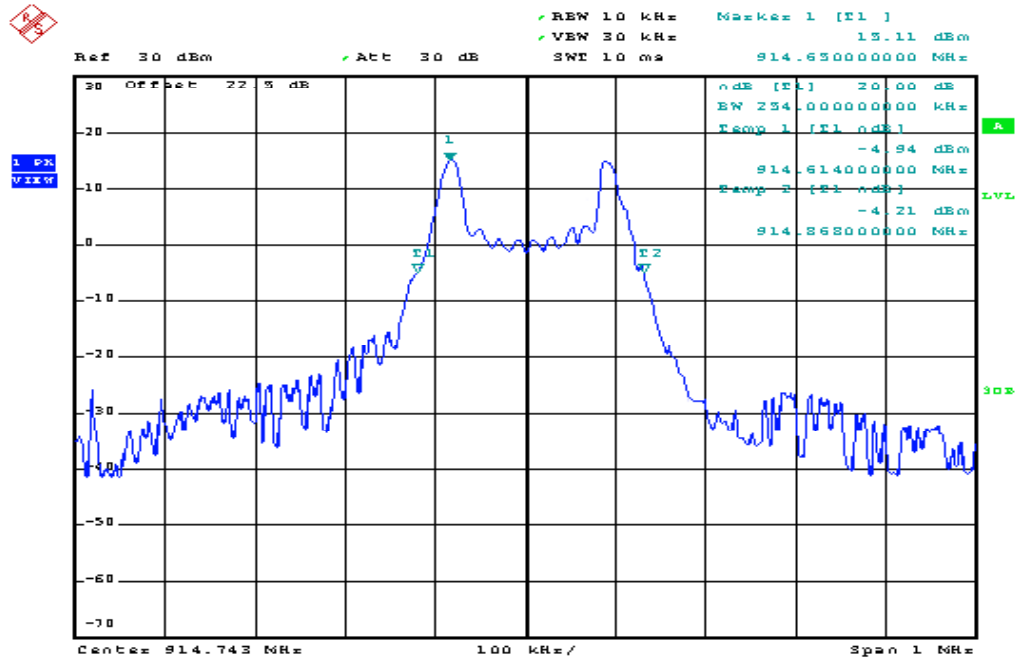

CH24 919.024MHz

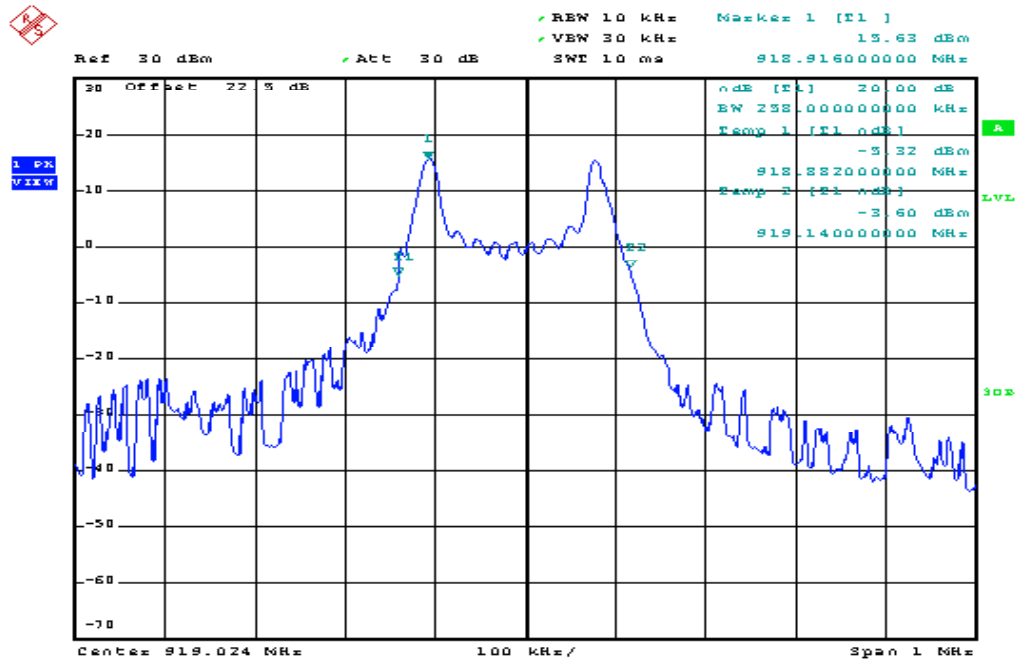

4 Carrier Frequency Separation test

4.1 Limit

Frequency hopping systems shall have hopping channel carrier frequencies separated by a minimum of 25kHz or the 20dB bandwidth of the hopping channel, whichever is greater. For frequency hopping systems operating in the 902–928 MHz band: if the 20 dB bandwidth of the hopping channel is less than 250 kHz, the system shall use at least 50 hopping frequencies and the average time of occupancy on any frequency shall not be greater than 0.4 seconds within a 20 second period; if the 20 dB bandwidth of the hopping channel is 250 kHz or greater, the system shall use at least 25 hopping frequencies and the average time of occupancy on any frequency shall not be greater than 0.4 seconds within a 10 second period. The maximum allowed 20 dB bandwidth of the hopping channel is 500 kHz.

4.2 Configuration of Measurement

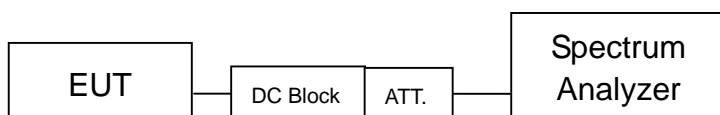

4.3 Test Procedure

The EUT was setup to ANSI C63.4, 2003; tested to FHSS test procedure of FCC Public Notice DA 00-705 for compliance to FCC 47CFR 15.247 requirements.

The carrier frequency separation per FCC Part15.247(a)(1) was measured using a 50 ohm spectrum analyzer with the resolutions bandwidth set at $\geq 1\%$ of the span, the video bandwidth \geq RBW, and the SPAN was wide enough to capture the peaks of two adjacent channels.

4.4 Test Result

PASS.

The final test data is shown as following pages.

Carrier Frequency Separation test

Modulation type	Frequency (MHz)	Separation (kHz)
FSK	909.5-909.957	464

Channel Separation

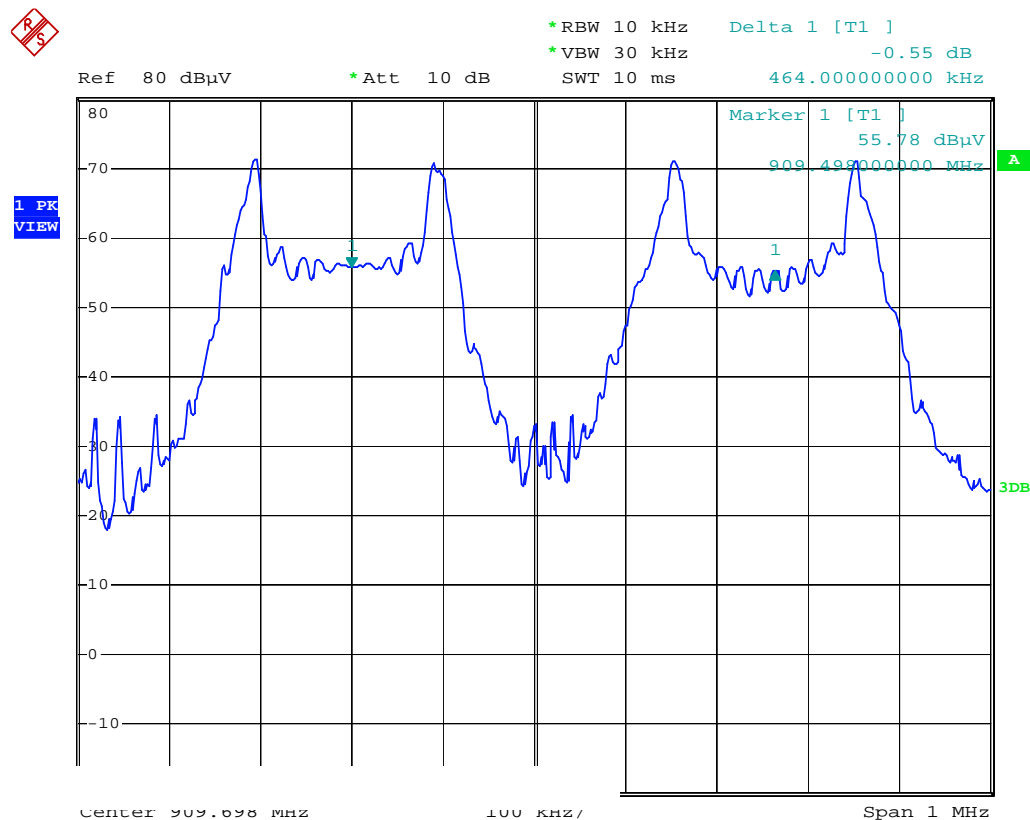

Date: 13.APR.2011 15:50:29

5 Number of hopping frequencies test

5.1 Configuration of Measurement

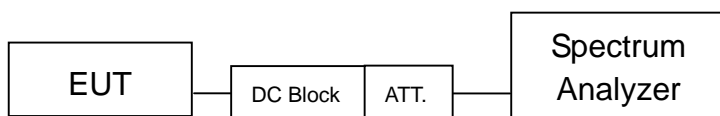

5.2 Test Procedure

The EUT was setup to ANSI C63.4, 2003; tested to FHSS test procedure of FCC Public Notice DA 00-705 for compliance to FCC 47CFR 15.247 requirements.

The number of hopping frequencies per FCC Part15.247(a)(1) was measured using a 50 ohm spectrum analyzer with the resolutions bandwidth set at $\geq 1\%$ of the span, the video bandwidth \geq RBW, and the SPAN was the frequency band of operation.

5.3 Test Result

PASS.

The final test data is shown as following pages.

Number of hopping frequencies test

Modulation	No. of Hopping CH.
FSK	25

Channel Number

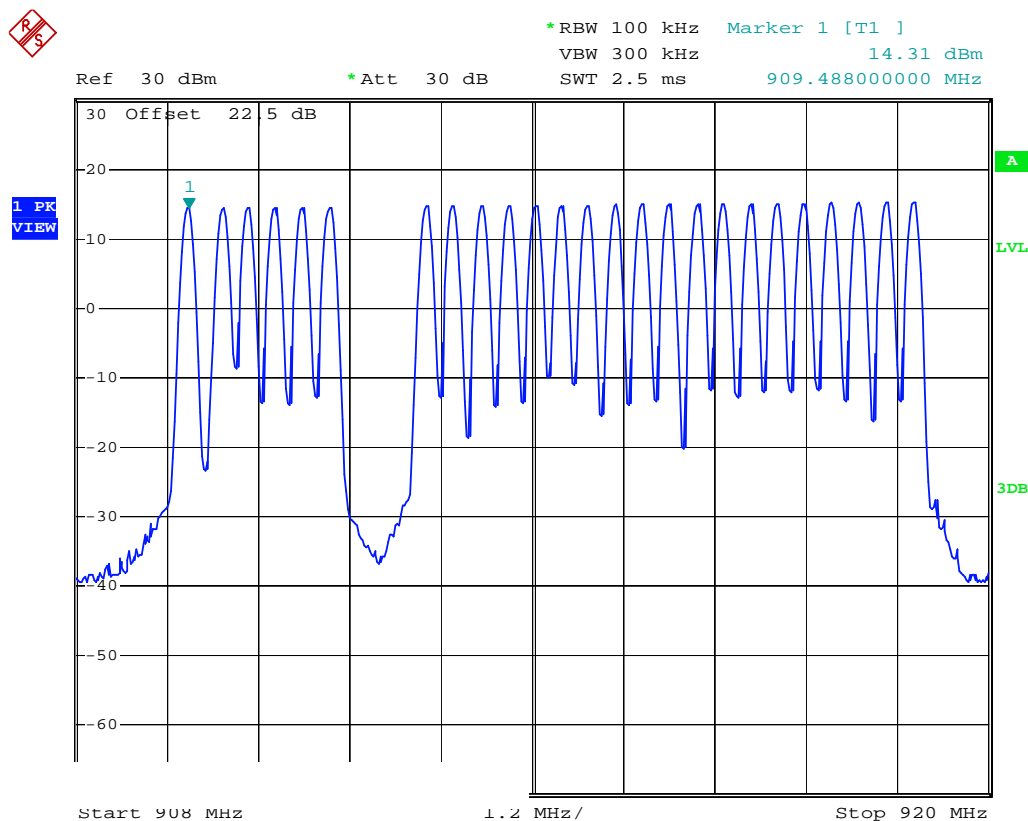

Date: 31.MAR.2011 16:57:11

6 Time of Occupancy (dwell time) test

6.1 Limit

For frequency hopping systems operating in the 902–928 MHz band: if the 20 dB bandwidth of the hopping channel is less than 250 kHz, the system shall use at least 50 hopping frequencies and the average time of occupancy on any frequency shall not be greater than 0.4 seconds within a 20 second period; if the 20 dB bandwidth of the hopping channel is 250 kHz or greater, the system shall use at least 25 hopping frequencies and the average time of occupancy on any frequency shall not be greater than 0.4 seconds within a 10 second period. The maximum allowed 20 dB bandwidth of the hopping channel is 500 kHz.

6.2 Configuration of Measurement

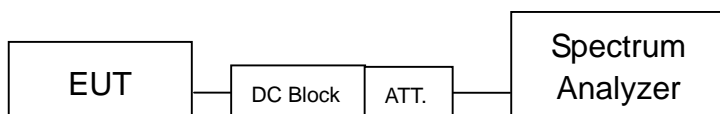

6.3 Test Procedure

The EUT was setup to ANSI C63.4, 2003; tested to FHSS test procedure of FCC Public Notice DA 00-705 for compliance to FCC 47CFR 15.247 requirements.

According to FCC Part15.247(a)(1) the time of occupancy (dwell time) was measured using a 50 ohm spectrum analyzer with the resolutions bandwidth set at 1MHz, the video bandwidth \geq RBW and the zero span function of spectrum analyzer was enable. The EUT has its hopping function enable.

6.4 Test Result

PASS.

The final test data is shown as following pages.

Time of Occupancy (dwell time) test

4 occurrences in 10 seconds x 50.6 ms = 202.4 ms which is less than 400 ms.

Dwell time-1

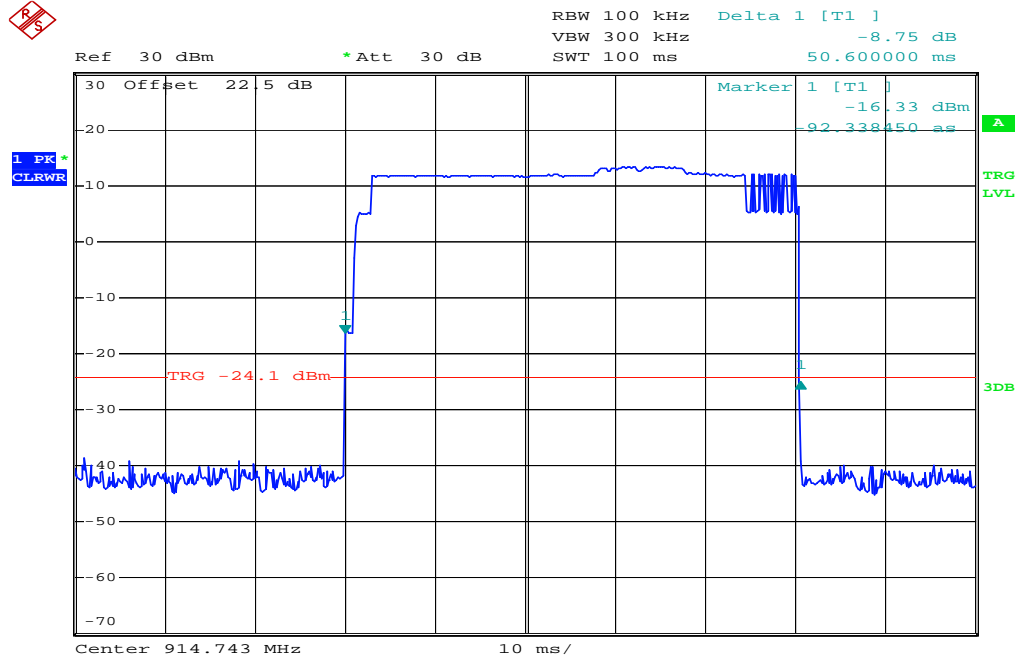

Date: 31.MAR.2011 16:49:42

Dwell time-2

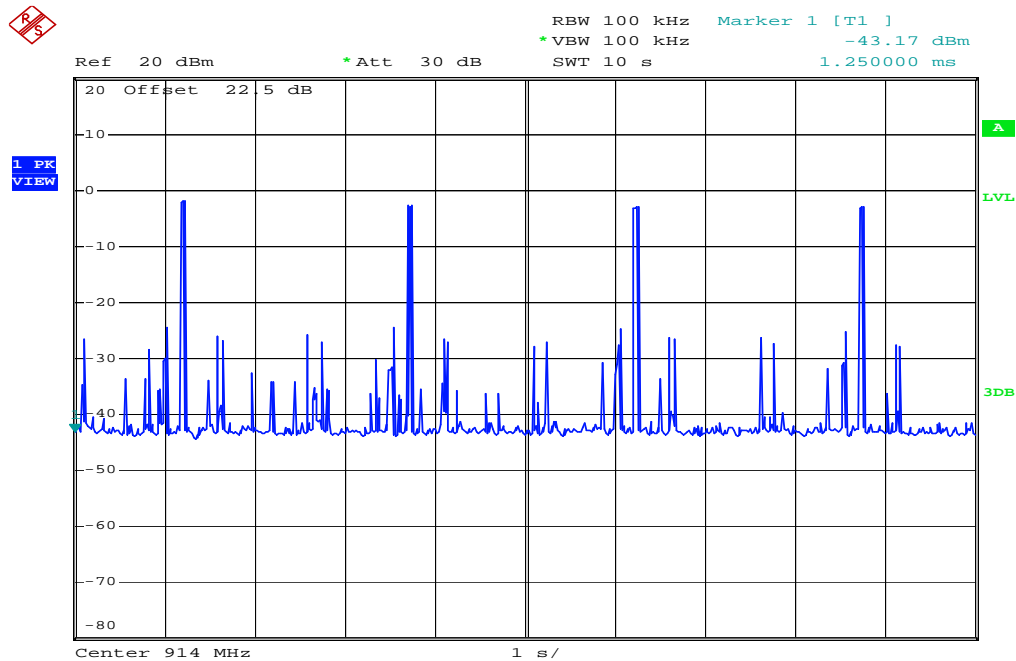

Date: 31.MAR.2011 15:46:06

7 Maximum Output Power test

7.1 Limit

For frequency hopping systems operating in the 902–928 MHz band: 1 watt for systems employing at least 50 hopping channels; and, 0.25 watts for systems employing less than 50 hopping channels, but at least 25 hopping channels, as permitted under paragraph (a)(1)(i) of this section.

7.2 Configuration of Measurement

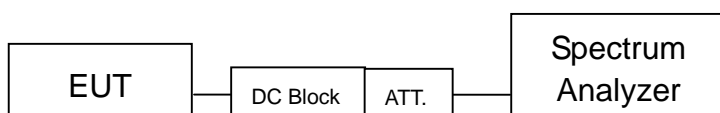

7.3 Test Procedure

The EUT was setup to ANSI C63.4, 2003; tested to FHSS test procedure of FCC Public Notice DA 00-705 for compliance to FCC 47CFR 15.247 requirements.

For FCC Part 15.247(b) the power output per was measured on the EUT using a 50 ohm SMA cable connected to peak power meter via power sensor. Peak output power was read directly from power meter. The test was performed at 3 channels (lowest, middle and highest).

7.4 Test Result

PASS.

The final test data is shown as following pages.

Maximum output power

CH	Freq. (MHz)	Temp. (°C)	Maximum transmit power		Limit (dBm)	Margin (dB)
			(dBm)	(watts)		
0	909.5	18.2	16.30	0.0427	24	-7.7
12	914.743	18.2	16.49	0.0446	24	-7.51
24	919.024	18.2	17.07	0.0509	24	-6.93

CH0 909.5MHz

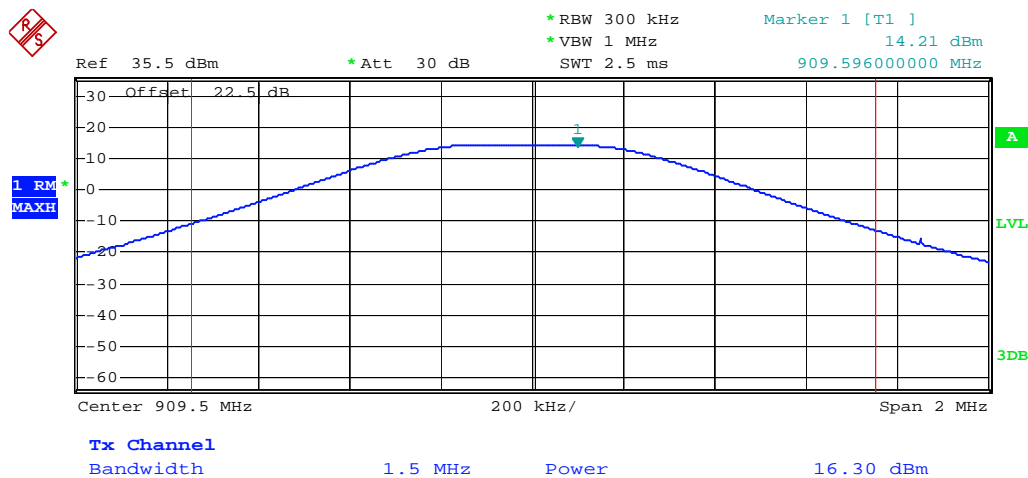

Date: 30.MAR.2011 12:12:35

CH12 914.743MHz

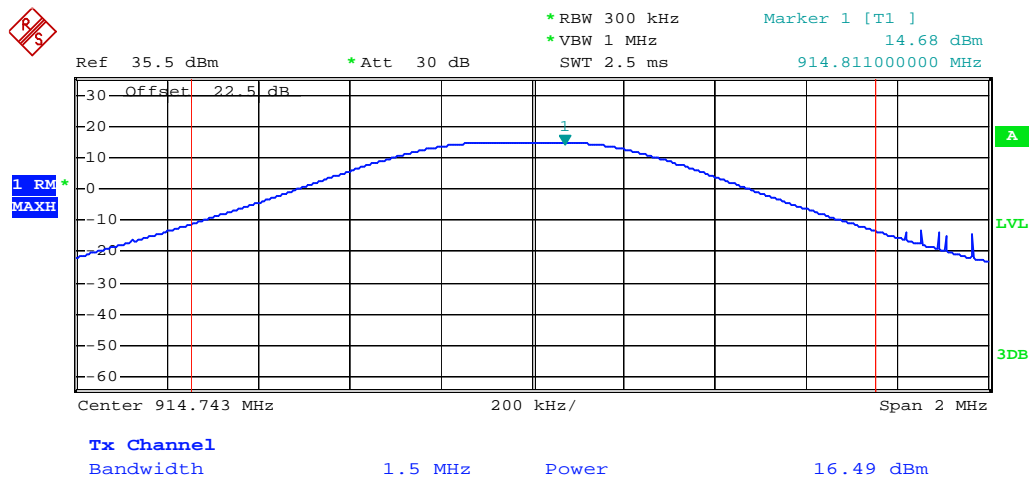

Date: 30.MAR.2011 12:11:31

CH24 919.024MHz

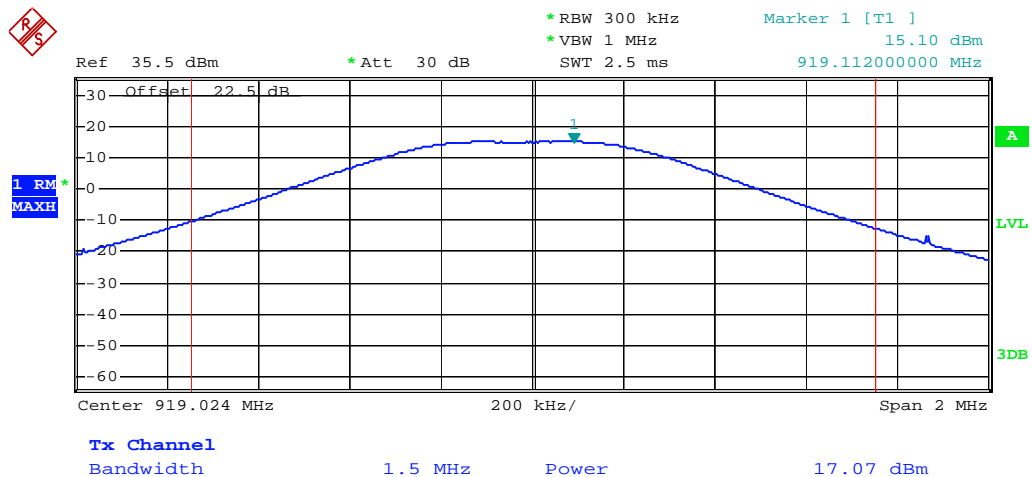

Date: 30.MAR.2011 12:12:11

8 RF Conducted spurious emission

8.1 Limit

According to FCC Part 15.247(d) requirement :

In any 100 kHz bandwidth outside the frequency band in which the spread spectrum or digitally modulated intentional radiator is operating, the radio frequency power that is produced by the intentional radiator shall be at least 20 dB below that in the 100 kHz bandwidth within the band that contains the highest level of the desired power, based on either an RF conducted or a radiated measurement, provided the transmitter demonstrates compliance with the peak conducted power limits.

8.2 Configuration of Measurement

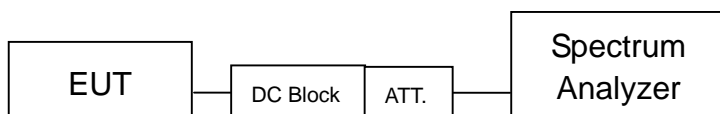

8.3 Test Procedure

The EUT was setup to ANSI C63.4, 2003; tested to FHSS test procedure of FCC Public Notice DA 00-705 for compliance to FCC 47CFR 15.247 requirements.

RF antenna conducted spurious emissions was measured from the EUT antenna port using a 50ohm spectrum analyzer with the resolution bandwidth set at 100 kHz, and the video bandwidth set at 100 kHz.

The measurements were performed from 30MHz to 25GHz.

8.4 Test Result

PASS.

The final test data is shown as following pages.

Conducted spurious emission

CH0 909.5MHz (30MHz~1GHz)

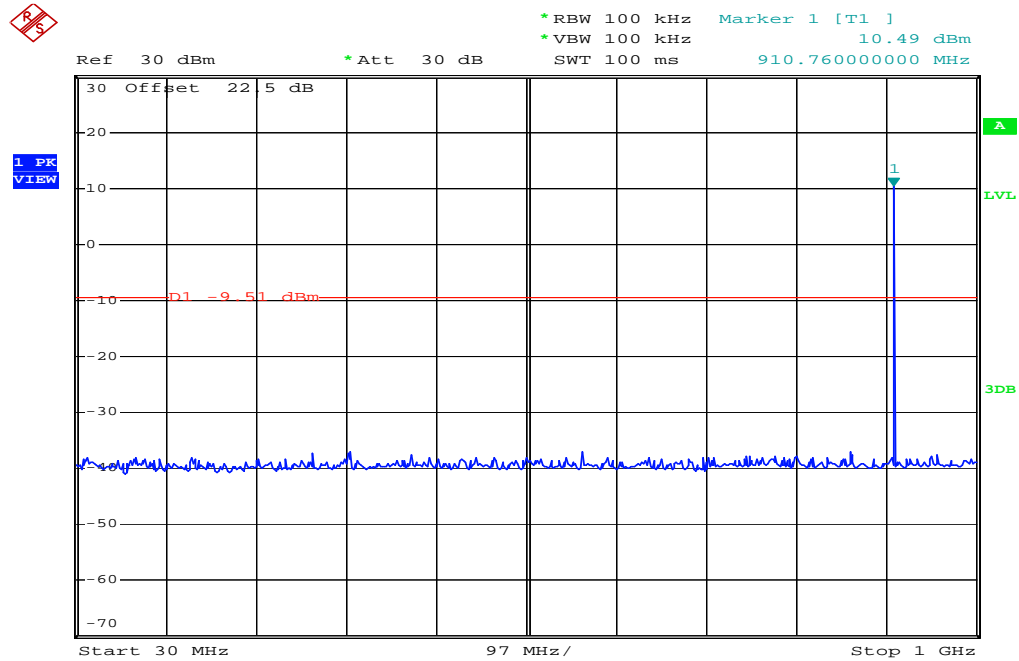

Date: 31.MAR.2011 14:53:39

CH0 909.5MHz (1GHz~5GHz)

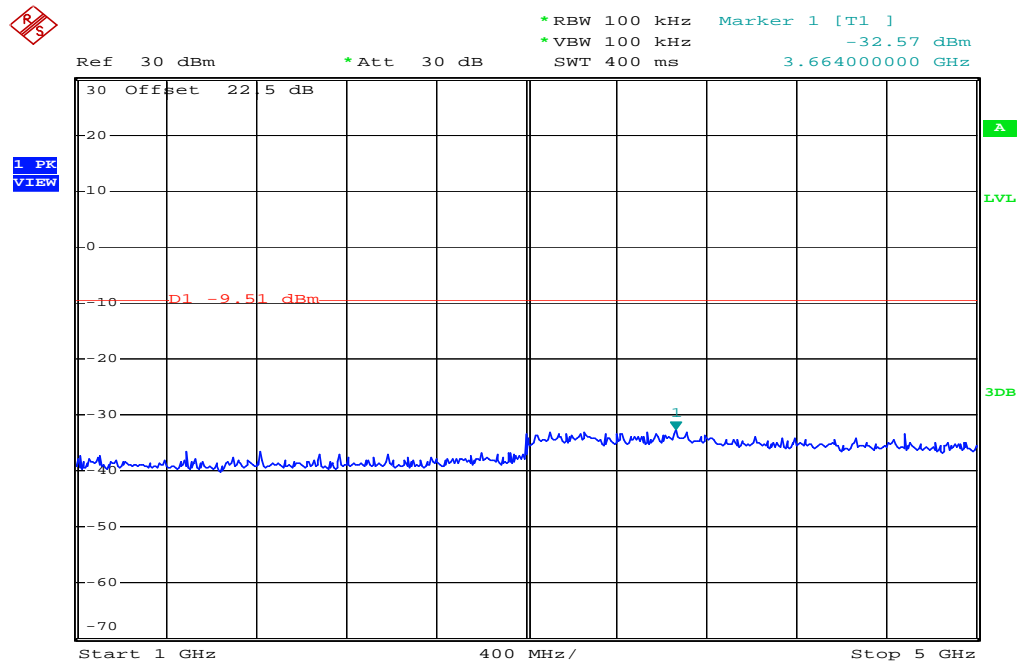

Date: 31.MAR.2011 14:55:38

CH0 909.5MHz (5GHz~10GHz)

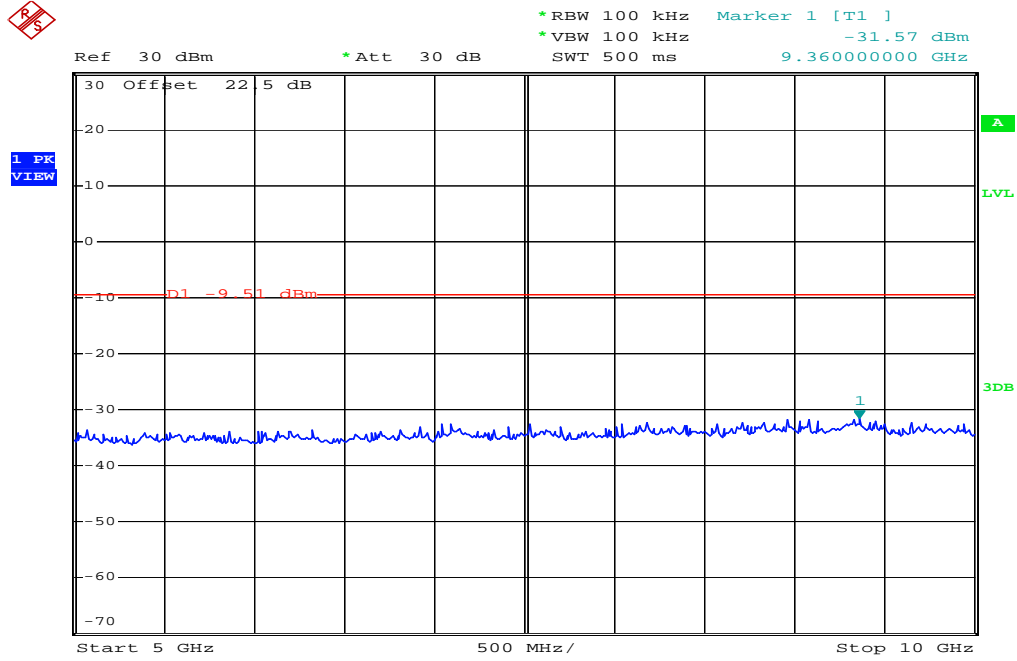

Date: 31.MAR.2011 14:56:58

CH12 914.743MHz (30MHz~1GHz)

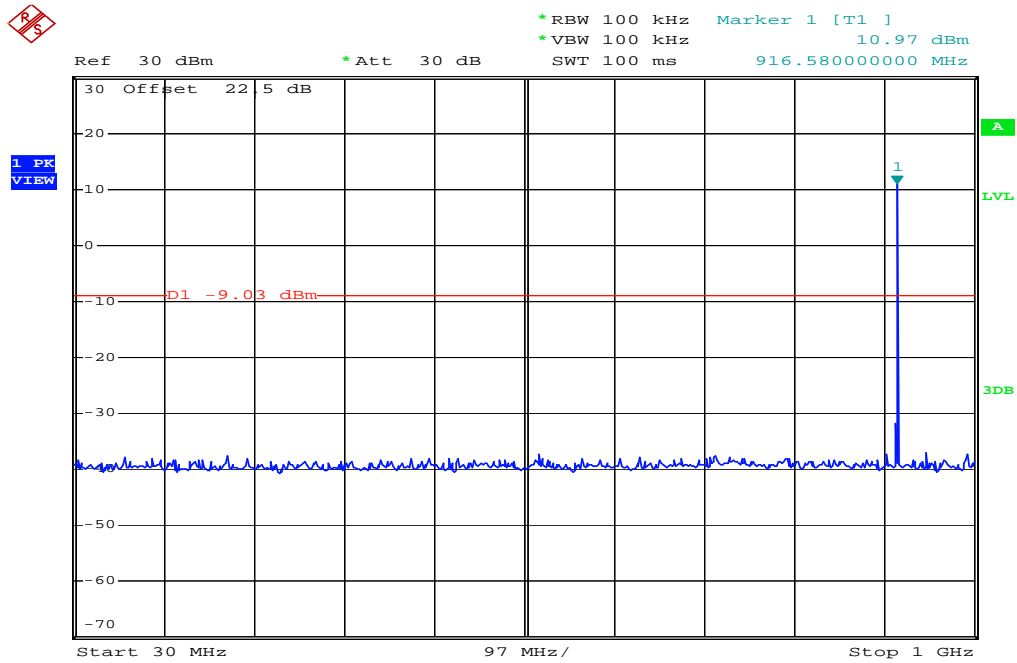

Date: 31.MAR.2011 15:00:41

CH12 914.743MHz (1GHz~5GHz)

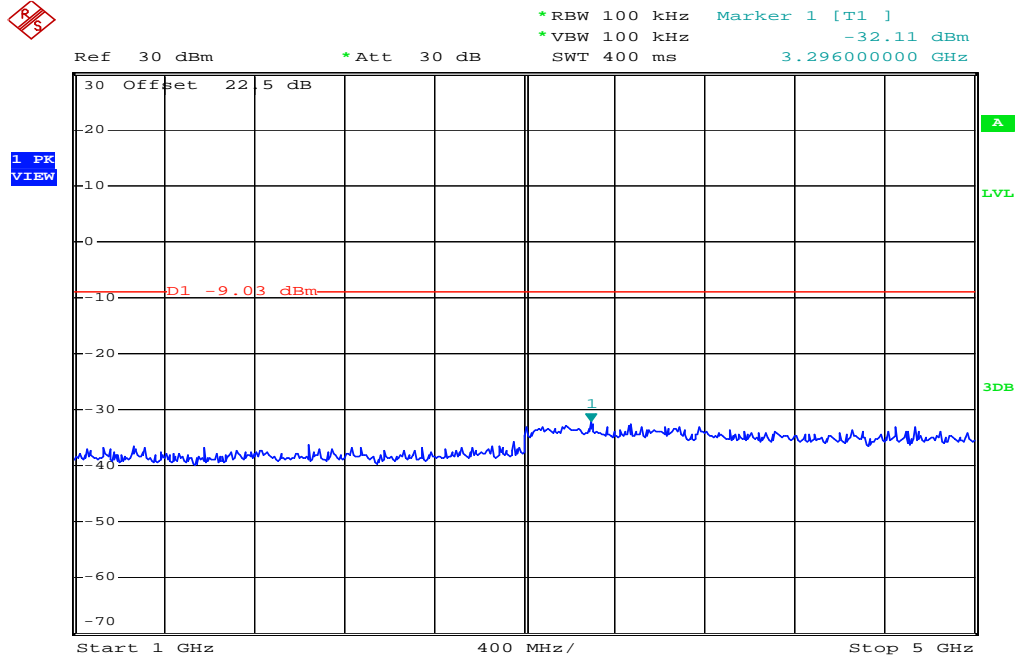

Date: 31.MAR.2011 15:03:15

CH12 914.743MHz (5GHz~10GHz)

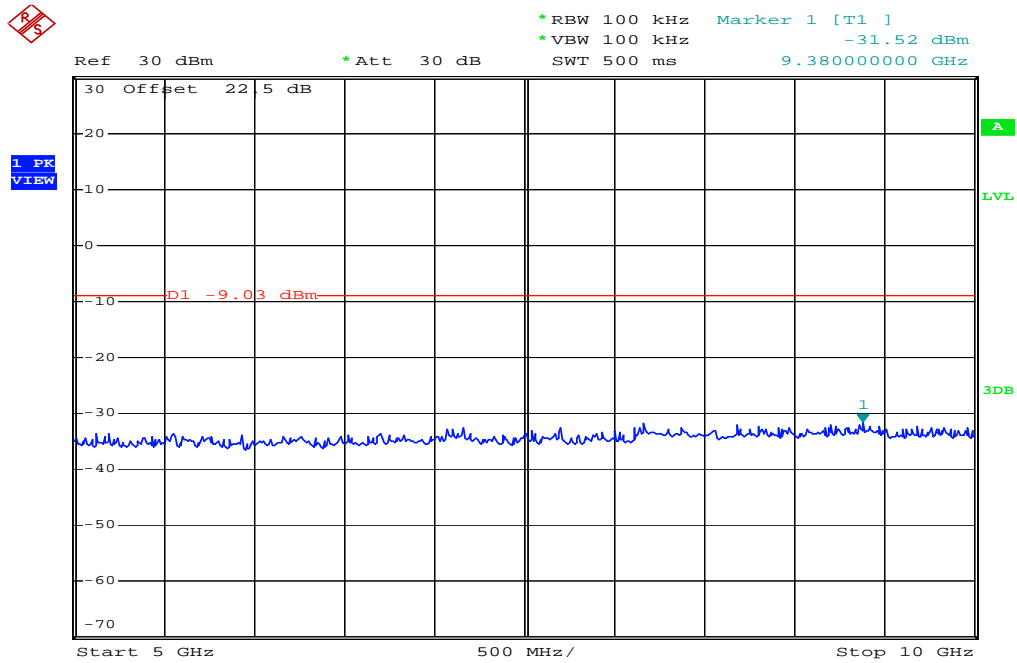

Date: 31.MAR.2011 15:04:28

CH24 919.024MHz (30MHz~1GHz)

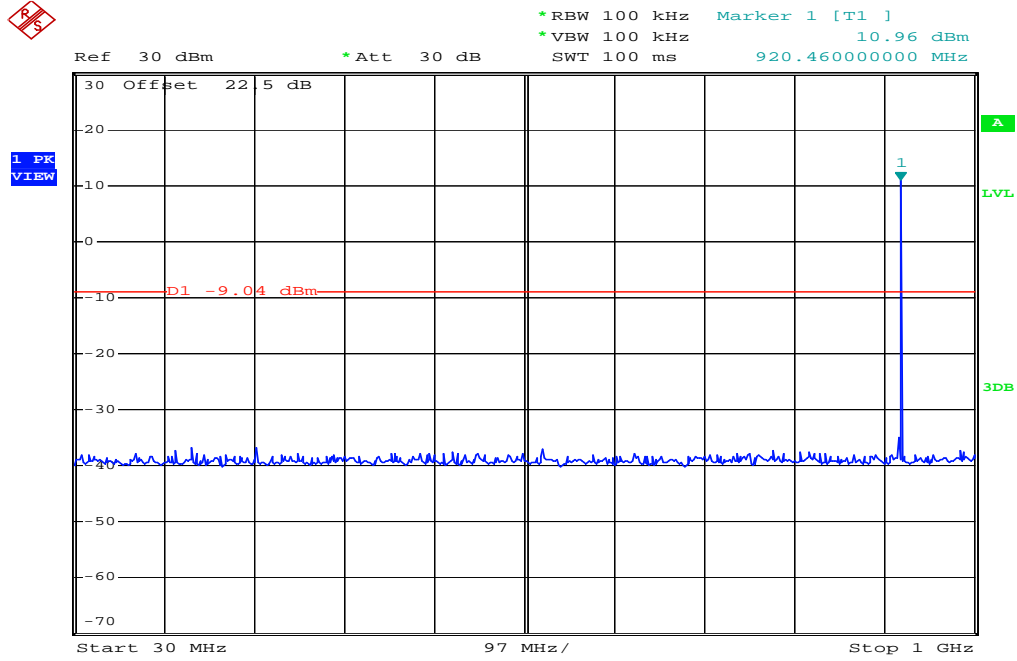

Date: 31.MAR.2011 15:07:14

CH24 919.024MHz (1GHz~5GHz)

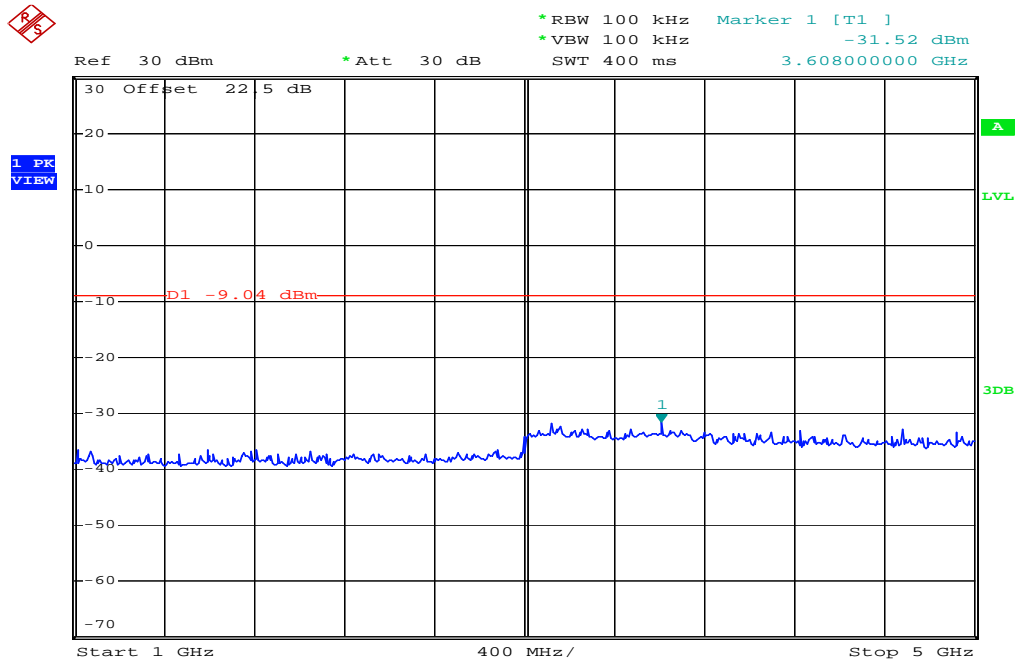

Date: 31.MAR.2011 15:08:58

CH24 919.024MHz (5GHz~10GHz)

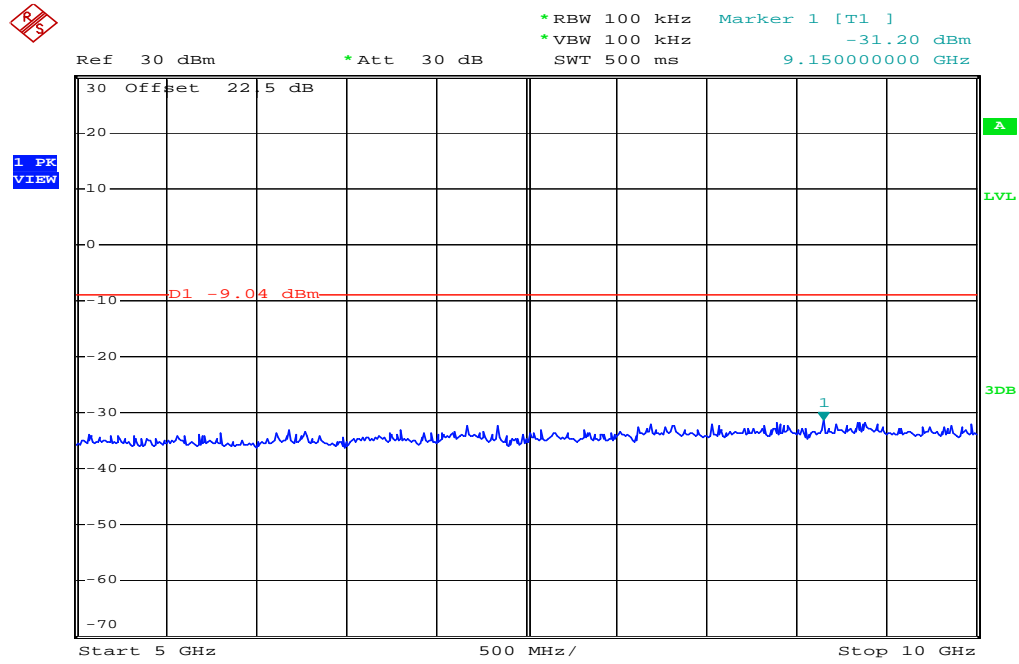

Date: 31.MAR.2011 15:10:21

9 RF Radiated spurious emission test

9.1 Limit

For intentional radiator, the radiated emission shall comply with FCC Part 15.209(a).

For intentional radiators, according to FCC Part 15.247 (a), operation under this provision is limited to frequency hopping and direct sequence spread spectrum, and the out band emission shall be comply with FCC Part 15.247 (c)

Frequency (MHz)	Field strength dB(μ V/m)	Measurement distance (meters)
1.705~30.0	29.5	30
30 ~ 88	40	3
88~216	43.5	3
216~960	46	3
Above 960	54	3

9.2 Configuration of Measurement

Measurement Frequency under 1GHz

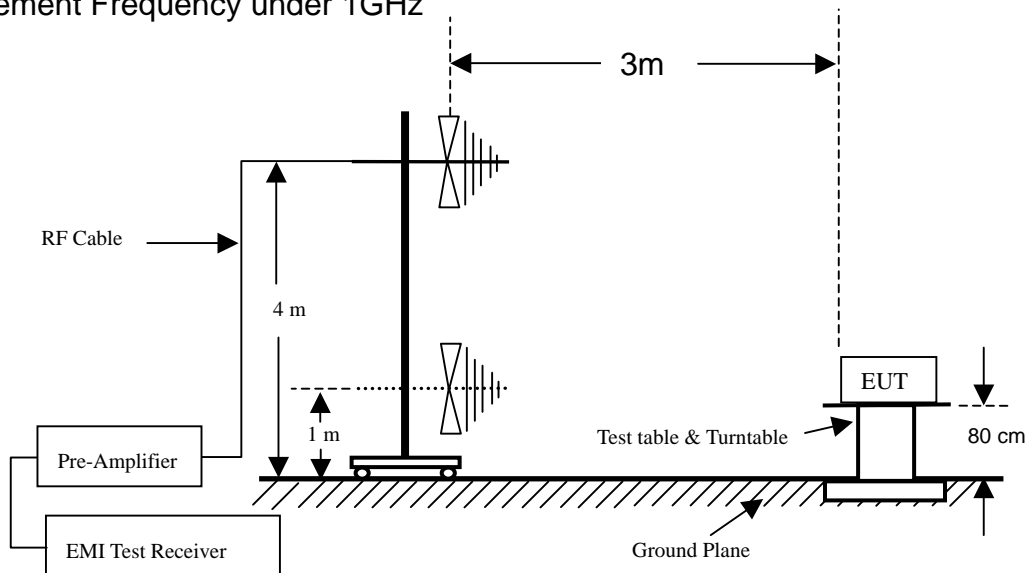

Measurement Frequency above 1GHz

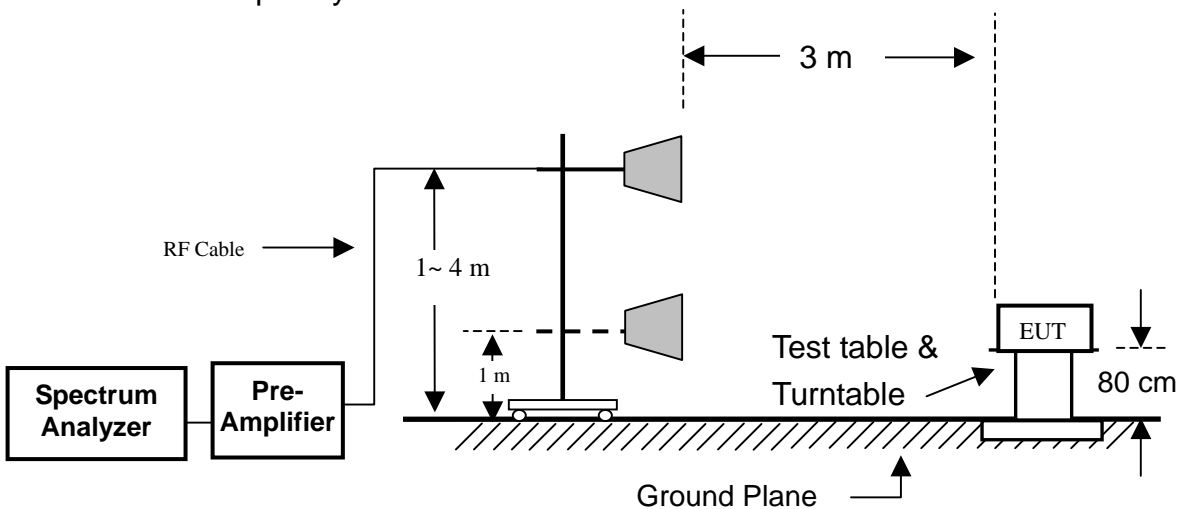

9.3 Test Procedure

The EUT was setup to ANSI C63.4, 2003; tested to FHSS test procedure of FCC Public Notice DA 00-705 for compliance to FCC 47CFR 15.247 requirements.

Radiated emission measurements were performed from 30MHz to 10GHz. Spectrum Analyzer set as below: For frequency range from 30MHz to 1GHz: RBW=100kHz or greater. For frequencies above 1GHz: set RBW=VBW=1MHz for peak detector and RBW=1MHz, VBW=10Hz for average detector.

The EUT for testing is arranged on a wooden turntable. If some peripherals apply to the EUT, the peripherals will be connected to EUT and whole system. During the test, all cables were arranged to present worst-case emissions. The signal is maximized through rotation. The height of antenna and polarization is changing constantly for exploring for maximum signal level. The height of antenna can be up to 4 meter and down to 1 meter.

9.4 Test Result

PASS.

The final test data is shown as following pages.

Radiated spurious emission

Test Environment

Ambient temperature : 20.2°C

Relative humidity : 58%

Radiated Emission below 1GHz

After verifying low, middle and high channel (909.05MHz, 914.743MHz and 919.024MHz) the worst case

Worst case was found at High channel								
Frequency (MHz)	Antenna Polarization	Reading (dB μ V)	Preamp (dB)	Correction Factor (dB/m)	Corrected Level (dB μ V/m)	Limits (dB μ V/m)	Margin (dB)	Det. Mode
65.320	H	49.96	33.30	7.53	24.19	40.00	-15.81	QP
123.350	H	48.12	33.03	14.23	29.32	43.52	-14.20	QP
165.560	H	46.89	33.36	16.77	30.30	43.52	-13.22	QP
186.300	H	46.00	33.40	18.23	30.83	43.52	-12.69	QP
223.300	H	46.85	33.33	19.22	32.74	46.02	-13.28	QP
257.400	H	44.41	33.47	20.46	31.40	46.02	-14.62	QP
45.630	V	48.69	33.20	12.52	28.01	40.00	-11.99	QP
116.300	V	48.85	33.00	13.98	29.83	43.52	-13.69	QP
147.850	V	44.96	33.18	16.93	28.71	43.52	-14.81	QP
185.500	V	45.30	33.40	18.76	30.66	43.52	-12.86	QP
226.300	V	45.16	33.36	19.78	31.58	46.02	-14.44	QP
268.300	V	42.56	33.50	21.21	30.27	46.02	-15.75	QP

Remark : Corrected Level = Reading + Correction Factor – Preamp

Correction Factor = Antenna Factor + Cable Loss

The present spurious only show those points are above noise level and the frequency range test from 30MHz to 1GHz.

Radiated spurious emission

Radiated Emission above 1GHz

CH0								
Frequency (MHz)	Antenna Polarization	Reading (dB μ V)	Preamp (dB)	Correction Factor (dB/m)	Corrected Level (dB μ V/m)	Limits (dB μ V/m)	Margin (dB)	Det. Mode
1819.00	H	53.56	26.16	29.69	57.09	74	-16.91	PK
1819.00	H	46.43	26.16	29.69	49.96	54	-4.04	AV
2728.50	H	49.24	26.25	31.79	54.78	74	-19.22	PK
2728.50	H	45.00	26.25	31.79	50.54	54	-3.46	AV
3638.00	H	47.20	26.17	33.61	54.64	74	-19.36	PK
3638.00	H	39.11	26.17	33.61	46.55	54	-7.45	AV
4547.50	H	41.22	26.09	36.04	51.17	54	-2.83	PK
5457.00	H	45.03	25.91	38.41	57.53	74	-16.47	PK
5457.00	H	32.40	25.91	38.41	44.90	54	-9.10	AV
6366.50	H	38.32	25.73	40.25	52.84	54	-1.16	PK
1819.00	V	54.60	26.16	29.69	58.13	74	-15.87	PK
1819.00	V	47.36	26.16	29.69	50.89	54	-3.11	AV
2728.50	V	52.00	26.25	31.79	57.54	74	-16.46	PK
2728.50	V	46.93	26.25	31.79	52.47	54	-1.53	AV
3638.00	V	47.67	26.17	33.61	55.11	74	-18.89	PK
3638.00	V	41.51	26.17	33.61	48.95	54	-5.05	AV
4547.50	V	40.59	26.09	36.04	50.54	54	-3.46	PK
5457.00	V	42.84	25.91	38.41	55.34	74	-18.66	PK
5457.00	V	35.63	25.91	38.41	48.13	54	-5.87	AV
6366.50	V	39.06	25.73	40.25	53.58	54	-0.42	PK

Remark : Corrected Level = Reading + Correction Factor – Preamp

Correction Factor = Antenna Factor + Cable Loss

* Mark indicated background noise level.

CH12								
Frequency (MHz)	Antenna Polarization	Reading (dB μ V)	Preamp (dB)	Correction Factor (dB/m)	Corrected Level (dB μ V/m)	Limits (dB μ V/m)	Margin (dB)	Det. Mode
1829.49	H	53.32	26.17	29.72	56.87	74	-17.13	PK
1829.49	H	44.63	26.17	29.72	48.18	54	-5.82	AV
2744.25	H	49.40	26.25	31.84	54.99	74	-19.01	PK
2744.25	H	43.73	26.25	31.84	49.32	54	-4.68	AV
3658.97	H	47.66	26.17	33.68	55.17	74	-18.83	PK
3658.97	H	42.10	26.17	33.68	49.61	54	-4.39	AV
4573.72	H	42.22	26.09	36.12	52.25	54	-1.75	PK
5488.46	H	44.60	25.90	38.48	57.18	74	-16.82	PK
5488.46	H	36.48	25.90	38.48	49.06	54	-4.94	AV
6403.20	H	39.10	25.72	40.35	53.73	54	-0.27	PK
1829.49	V	55.63	26.17	29.72	59.18	74	-14.82	PK
1829.49	V	46.56	26.17	29.72	50.11	54	-3.89	AV
2744.25	V	49.89	26.25	31.84	55.48	74	-18.52	PK
2744.25	V	46.06	26.25	31.84	51.65	54	-2.35	AV
3658.97	V	49.89	26.17	33.68	57.40	74	-16.60	PK
3658.97	V	45.19	26.17	33.68	52.70	54	-1.30	AV
4573.72	V	41.32	26.09	36.12	51.35	54	-2.65	PK
5488.46	V	45.32	25.90	38.48	57.90	74	-16.10	PK
5488.46	V	35.86	25.90	38.48	48.44	54	-5.56	AV
6403.20	V	38.23	25.72	40.35	52.86	54	-1.14	PK

Remark : Corrected Level = Reading + Correction Factor – Preamp

Correction Factor = Antenna Factor + Cable Loss

* Mark indicated background noise level.

CH24								
Frequency (MHz)	Antenna Polarization	Reading (dB μ V)	Preamp (dB)	Correction Factor (dB/m)	Corrected Level (dB μ V/m)	Limits (dB μ V/m)	Margin (dB)	Det. Mode
1838.05	H	52.25	26.17	29.75	55.83	74	-18.17	PK
1838.05	H	43.32	26.17	29.75	46.90	54	-7.10	AV
2757.07	H	48.68	26.25	31.87	54.30	74	-19.70	PK
2757.07	H	44.72	26.25	31.87	50.34	54	-3.66	AV
3676.10	H	48.80	26.16	33.73	56.37	74	-17.63	PK
3676.10	H	44.21	26.16	33.73	51.78	54	-2.22	AV
4595.12	H	43.30	26.08	36.19	53.41	54	-0.59	PK
5514.14	H	44.36	25.90	38.52	56.98	74	-17.02	PK
5514.14	H	36.10	25.90	38.52	48.72	54	-5.28	AV
6433.17	H	39.00	25.71	40.43	53.72	54	-0.28	PK
1838.05	V	54.96	26.17	29.75	58.54	74	-15.46	PK
1838.05	V	46.53	26.17	29.75	50.11	54	-3.89	AV
2757.07	V	49.56	26.25	31.87	55.18	74	-18.82	PK
2757.07	V	46.32	26.25	31.87	51.94	54	-2.06	AV
3676.10	V	50.89	26.16	33.73	58.46	74	-15.54	PK
3676.10	V	45.33	26.16	33.73	52.90	54	-1.10	AV
4595.12	V	42.20	26.08	36.19	52.31	54	-1.69	PK
5514.14	V	43.33	25.90	38.52	55.95	74	-18.05	PK
5514.14	V	33.97	25.90	38.52	46.59	54	-7.41	AV
6433.17	V	39.12	25.71	40.43	53.84	54	-0.16	PK

Remark : Corrected Level = Reading + Correction Factor – Preamp

Correction Factor = Antenna Factor + Cable Loss

* Mark indicated background noise level.

10 AC Power Line Conducted Emission test

10.1 Limits

Frequency (MHz)	Quasi-Peak (dB μ V)	Average (dB μ V)
0.15 to 0.5	66 to 56	56 to 46
> 0.5 to 5	56	46
> 5 to 30	60	50

NOTE: The limit decreases linearly with the logarithm of the frequency in the range 0.15 MHz to 0.50 MHz.

10.2 Configuration of Measurement

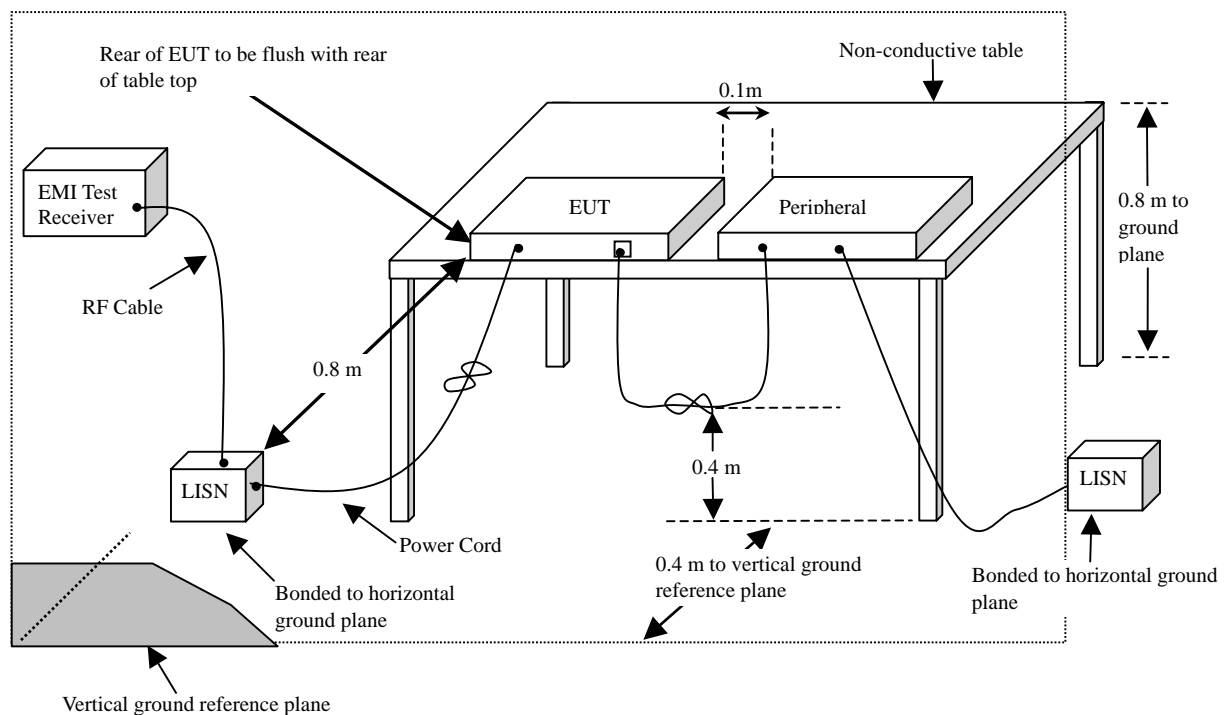

10.3 Test Procedures

The EUT was setup to ANSI C63.4, 2003; tested to FHSS test procedure of FCC Public Notice DA 00-705 for compliance to FCC 47CFR 15.247 requirements.

- 1) The EUT was placed 80cm height above ground on a non-conductive table and vertical conducting plane located 40cm to the rear of the EUT.
- 2) The EUT was connected to the main power through Line Impedance Stabilization Networks (LISN). This setup provided a 50ohm/50mH coupling impedance for the measuring equipment. The auxiliary equipment will place in secondary LISN.
- 3) Both sides (Line and Neutral) of AC line are checked for maximum conducted interference. In order to find the maximum emission, the relative positions of equipment and all of the interface cables must be changed according to ANSI C63.4/2003 on conducted measurement.

10.4 Test Result

PASS.

The final test data is shown as following pages.

Power Line Conducted Test Data

EUT: Transmitter CLIENT: Nutek Corporation MODEL: SS92P RATING: 120V/60Hz Temperature: 20.8 °C Humidity: 53 %	POLARITY: Line DISTANCE: Serial No.: FILE/DATA#: Nutek.emi/2 OPERATOR: Elli TEST SITE: Conduction 2
--	--

Frequency (MHz)	Factor (dB)	Meter Reading (dBµV)		Emission Level (dBµV)		Limits (dBµV)		Margin (dB)	
		Quasi-Peak	Average	Quasi-Peak	Average	Quasi-Peak	Average	Quasi-Peak	Average
0.185	0.20	43.15	32.69	43.35	32.89	64.26	54.26	-20.91	-21.37
0.232	0.19	38.74	26.37	38.93	26.56	62.38	52.38	-23.45	-25.82
0.423	0.18	45.17	36.98	45.35	37.16	57.39	47.39	-12.04	-10.23
0.795	0.19	33.31	25.68	33.50	25.87	56.00	46.00	-22.50	-20.13
1.427	0.18	31.21	22.61	31.39	22.79	56.00	46.00	-24.61	-23.21
2.709	0.14	29.59	22.27	29.73	22.41	56.00	46.00	-26.27	-23.59

Remark:

1. All readings are Quasi-Peak and Average values.
2. Factor = Insertion Loss + Cable Loss.

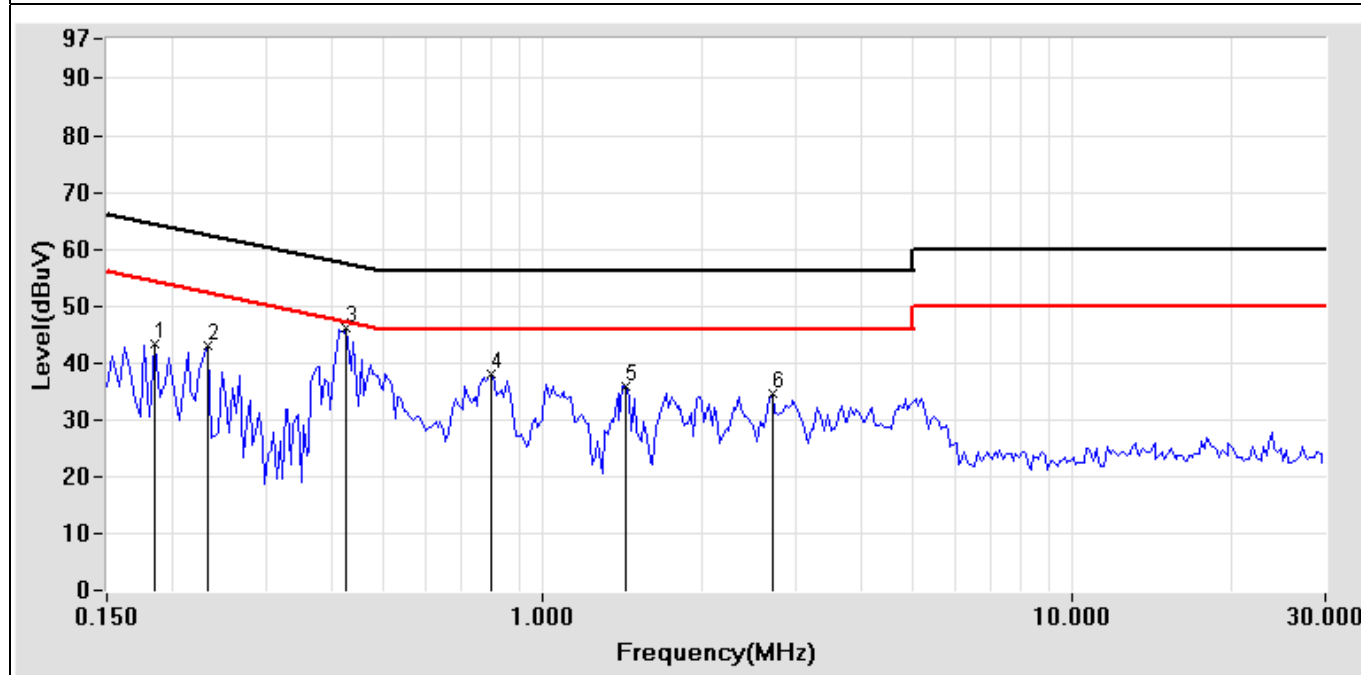

Test Mode: Frequency 909.5MHz

Power Line Conducted Test Data

EUT: Transmitter CLIENT: Nutek Corporation MODEL: SS92P RATING: 120V/60Hz Temperature: 20.8 °C Humidity: 53 %	POLARITY: Neutral DISTANCE: Serial No.: FILE/DATA#: Nutek.emi/3 OPERATOR: Elli TEST SITE: Conduction 2
--	---

Frequency (MHz)	Factor (dB)	Meter Reading (dBμV)		Emission Level (dBμV)		Limits (dBμV)		Margin (dB)	
		Quasi-Peak	Average	Quasi-Peak	Average	Quasi-Peak	Average	Quasi-Peak	Average
0.158	0.21	42.79	32.50	43.00	32.71	65.57	55.57	-22.57	-22.86
0.170	0.21	42.34	31.62	42.55	31.83	64.96	54.96	-22.41	-23.13
0.232	0.19	35.75	27.19	35.94	27.38	62.38	52.38	-26.44	-25.00
0.431	0.18	43.70	35.70	43.88	35.88	57.23	47.23	-13.35	-11.35
1.720	0.16	28.23	21.78	28.39	21.94	56.00	46.00	-27.61	-24.06
3.685	0.17	28.36	20.29	28.53	20.46	56.00	46.00	-27.47	-25.54

Remark:

1. All readings are Quasi-Peak and Average values.
2. Factor = Insertion Loss + Cable Loss.

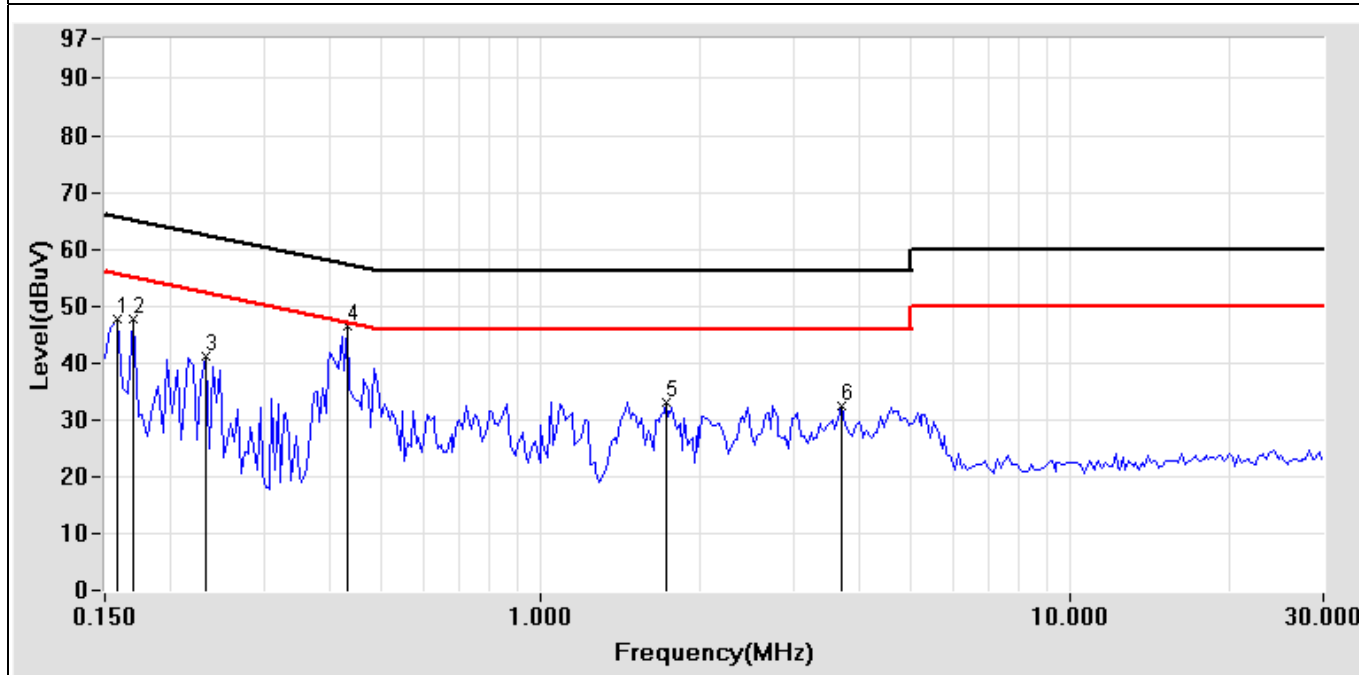

Test Mode: Frequency 909.5MHz

Power Line Conducted Test Data

EUT: Transmitter CLIENT: Nutek Corporation MODEL: SS92P RATING: 120V/60Hz Temperature: 20.8 °C Humidity: 53 %	POLARITY: Line DISTANCE: Serial No.: FILE/DATA#: Nutek.emi/5 OPERATOR: Elli TEST SITE: Conduction 2
--	--

Frequency (MHz)	Factor (dB)	Meter Reading (dBµV)		Emission Level (dBµV)		Limits (dBµV)		Margin (dB)	
		Quasi-Peak	Average	Quasi-Peak	Average	Quasi-Peak	Average	Quasi-Peak	Average
0.154	0.21	42.80	32.58	43.01	32.79	65.78	55.78	-22.77	-22.99
0.228	0.19	36.67	24.10	36.86	24.29	62.52	52.52	-25.66	-28.23
0.427	0.18	42.64	35.07	42.82	35.25	57.31	47.31	-14.49	-12.06
0.834	0.19	30.11	21.23	30.30	21.42	56.00	46.00	-25.70	-24.58
1.755	0.17	28.53	19.36	28.70	19.53	56.00	46.00	-27.30	-26.47
4.966	0.30	27.97	19.29	28.27	19.59	56.00	46.00	-27.73	-26.41

Remark:

1. All readings are Quasi-Peak and Average values.
2. Factor = Insertion Loss + Cable Loss.

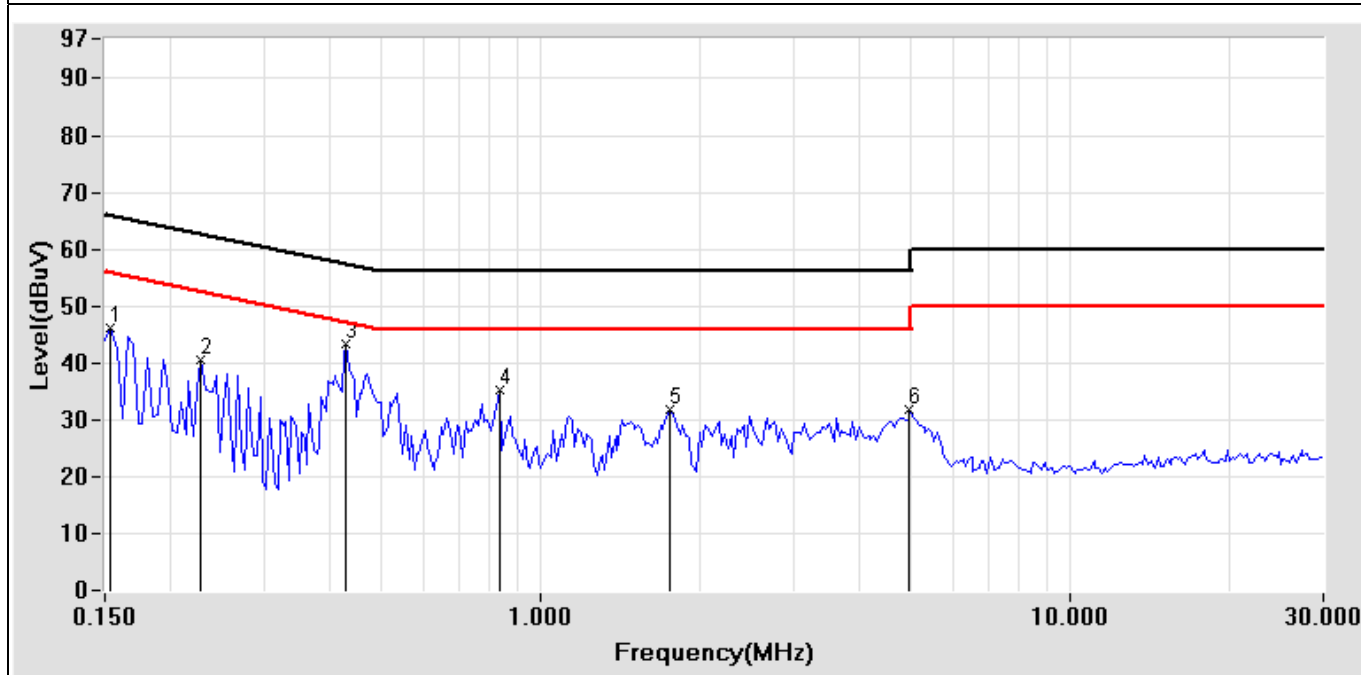

Test Mode: Frequency 914.743MHz

Power Line Conducted Test Data

EUT: Transmitter CLIENT: Nutek Corporation MODEL: SS92P RATING: 120V/60Hz Temperature: 20.8 °C Humidity: 53 %	POLARITY: Neutral DISTANCE: Serial No.: FILE/DATA#: Nutek.emi/4 OPERATOR: Elli TEST SITE: Conduction 2
--	---

Frequency (MHz)	Factor (dB)	Meter Reading (dBµV)		Emission Level (dBµV)		Limits (dBµV)		Margin (dB)	
		Quasi-Peak	Average	Quasi-Peak	Average	Quasi-Peak	Average	Quasi-Peak	Average
0.166	0.21	42.70	32.43	42.91	32.64	65.16	55.16	-22.25	-22.52
0.213	0.19	37.63	24.48	37.82	24.67	63.09	53.09	-25.27	-28.42
0.427	0.18	43.10	36.54	43.28	36.72	57.31	47.31	-14.03	-10.59
0.795	0.19	29.68	21.68	29.87	21.87	56.00	46.00	-26.13	-24.13
1.759	0.17	28.48	20.32	28.65	20.49	56.00	46.00	-27.35	-25.51
4.599	0.25	27.99	20.32	28.24	20.57	56.00	46.00	-27.76	-25.43

Remark:

1. All readings are Quasi-Peak and Average values.
2. Factor = Insertion Loss + Cable Loss.

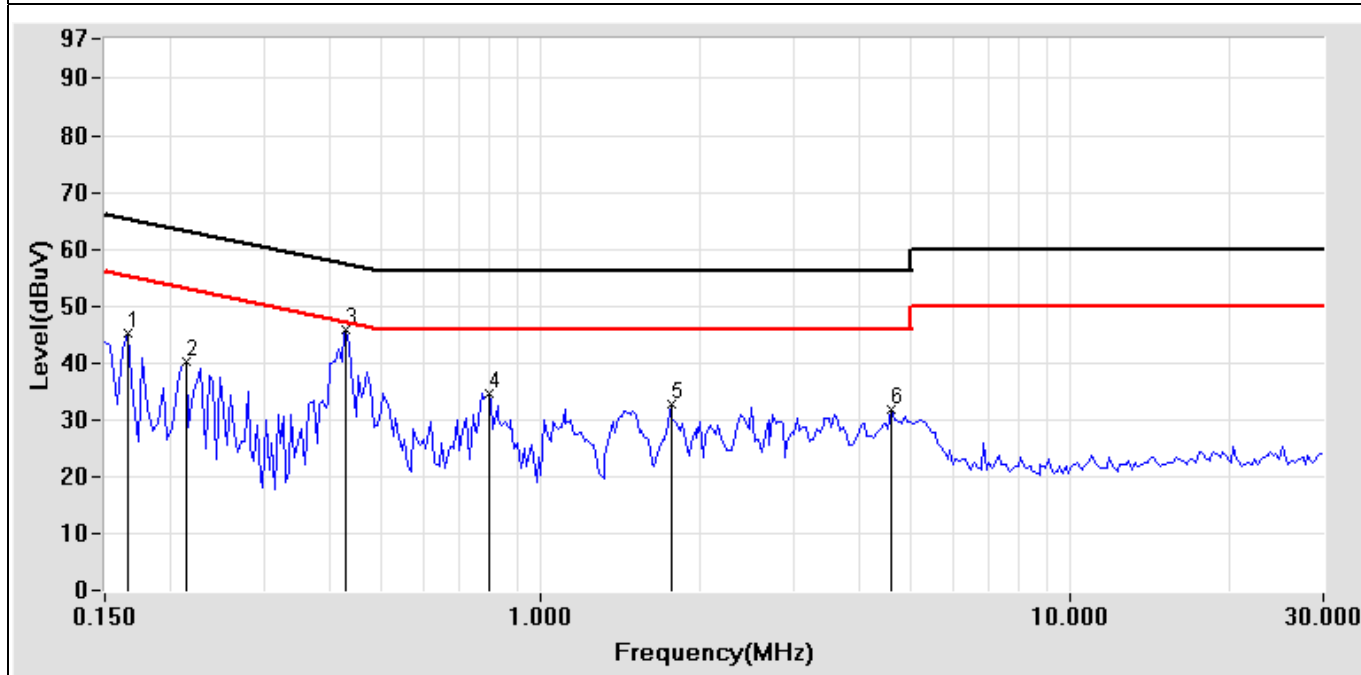

Test Mode: Frequency 914.743MHz

Power Line Conducted Test Data

EUT: Transmitter CLIENT: Nutek Corporation MODEL: SS92P RATING: 120V/60Hz Temperature: 20.8 °C Humidity: 53 %	POLARITY: Line DISTANCE: Serial No.: FILE/DATA#: Nutek.emi/6 OPERATOR: Elli TEST SITE: Conduction 2
--	--

Frequency (MHz)	Factor (dB)	Meter Reading (dBμV)		Emission Level (dBμV)		Limits (dBμV)		Margin (dB)	
		Quasi-Peak	Average	Quasi-Peak	Average	Quasi-Peak	Average	Quasi-Peak	Average
0.150	0.22	43.20	31.80	43.42	32.02	66.00	56.00	-22.58	-23.98
0.189	0.20	39.07	25.91	39.27	26.11	64.08	54.08	-24.81	-27.97
0.427	0.18	42.94	36.19	43.12	36.37	57.31	47.31	-14.19	-10.94
0.818	0.19	30.39	22.43	30.58	22.62	56.00	46.00	-25.42	-23.38
1.443	0.18	29.69	20.69	29.87	20.87	56.00	46.00	-26.13	-25.13
4.373	0.25	28.53	19.14	28.78	19.39	56.00	46.00	-27.22	-26.61

Remark:

1. All readings are Quasi-Peak and Average values.
2. Factor = Insertion Loss + Cable Loss.

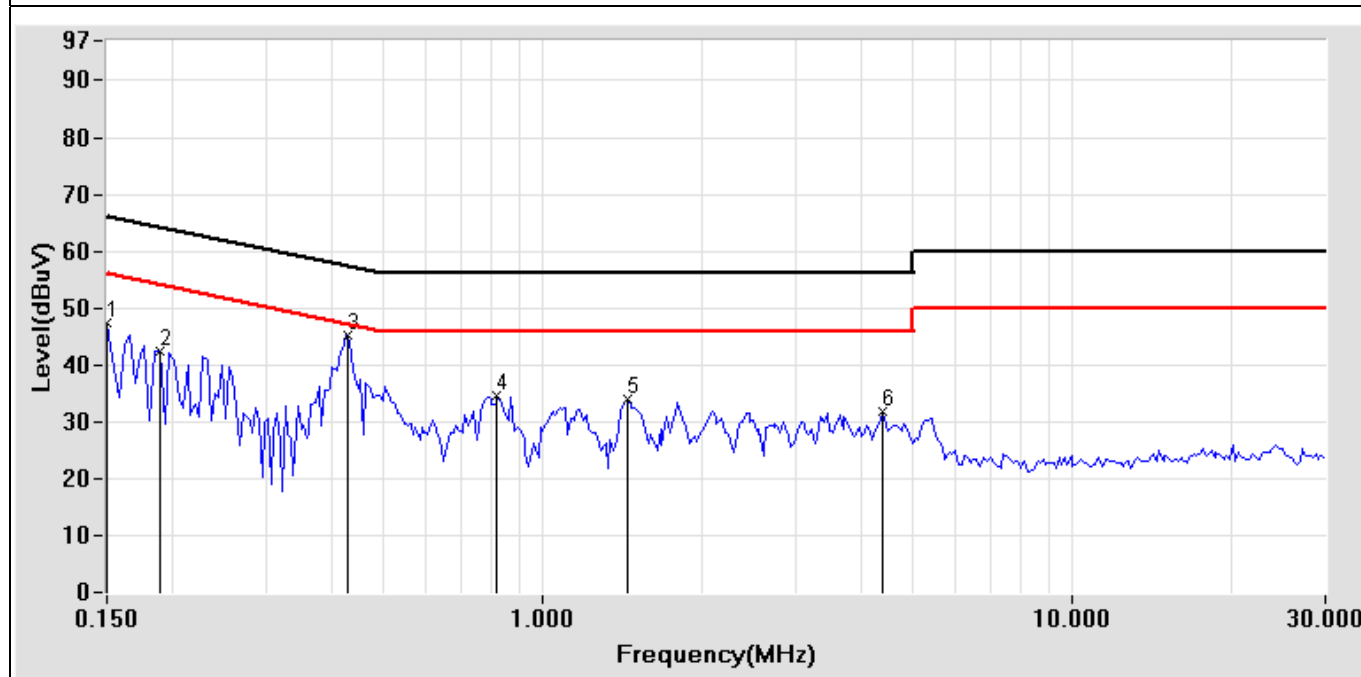

Test Mode: Frequency 919.024MHz

Power Line Conducted Test Data

EUT: Transmitter CLIENT: Nutek Corporation MODEL: SS92P RATING: 120V/60Hz Temperature: 20.8 °C Humidity: 53 %	POLARITY: Neutral DISTANCE: Serial No.: FILE/DATA#: Nutek.emi/7 OPERATOR: Elli TEST SITE: Conduction 2
--	---

Frequency (MHz)	Factor (dB)	Meter Reading (dBμV)		Emission Level (dBμV)		Limits (dBμV)		Margin (dB)	
		Quasi-Peak	Average	Quasi-Peak	Average	Quasi-Peak	Average	Quasi-Peak	Average
0.150	0.22	42.29	32.88	42.51	33.10	66.00	56.00	-23.49	-22.90
0.209	0.19	37.69	25.71	37.88	25.90	63.24	53.24	-25.36	-27.34
0.423	0.18	41.99	34.14	42.17	34.32	57.39	47.39	-15.22	-13.07
1.470	0.18	27.70	19.84	27.88	20.02	56.00	46.00	-28.12	-25.98
2.447	0.15	28.62	19.53	28.77	19.68	56.00	46.00	-27.23	-26.32
4.873	0.27	28.23	19.76	28.50	20.03	56.00	46.00	-27.50	-25.97

Remark:

1. All readings are Quasi-Peak and Average values.
2. Factor = Insertion Loss + Cable Loss.

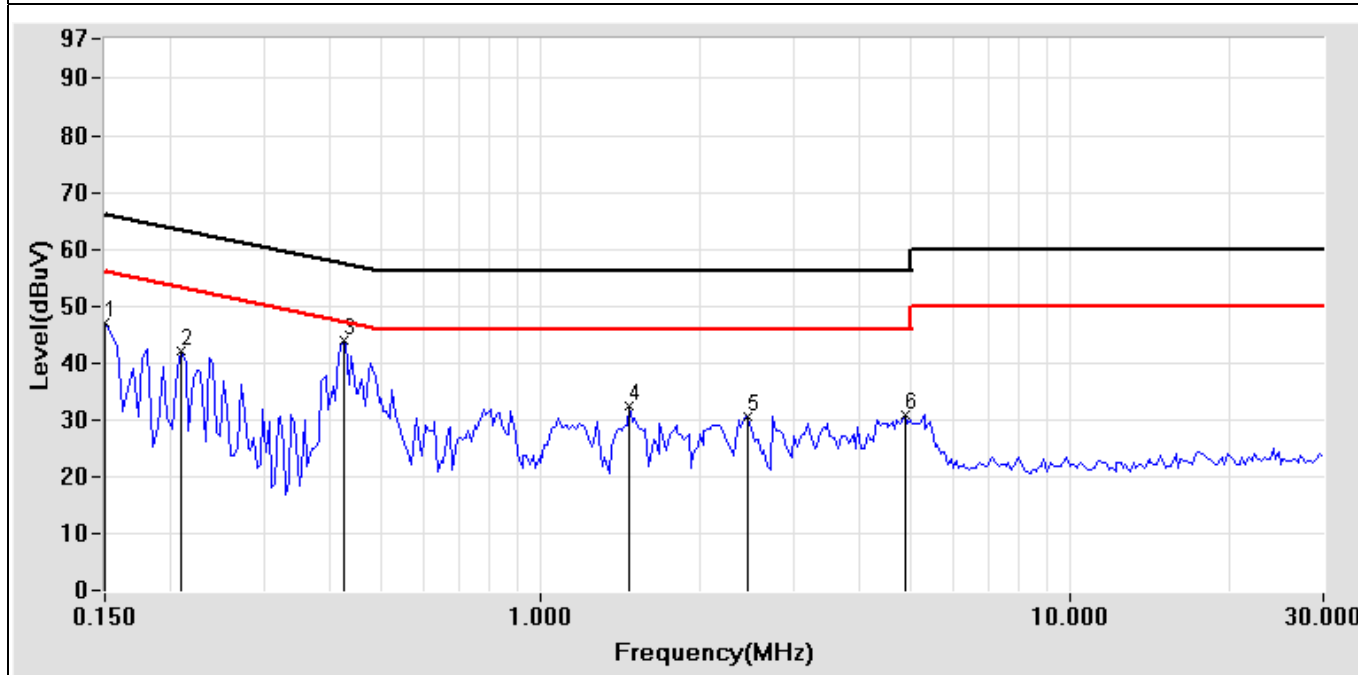

Test Mode: Frequency 919.024MHz