

REVISIONS				
REV.	ACC.	DESCRIPTION	DRN.	DATE
△				

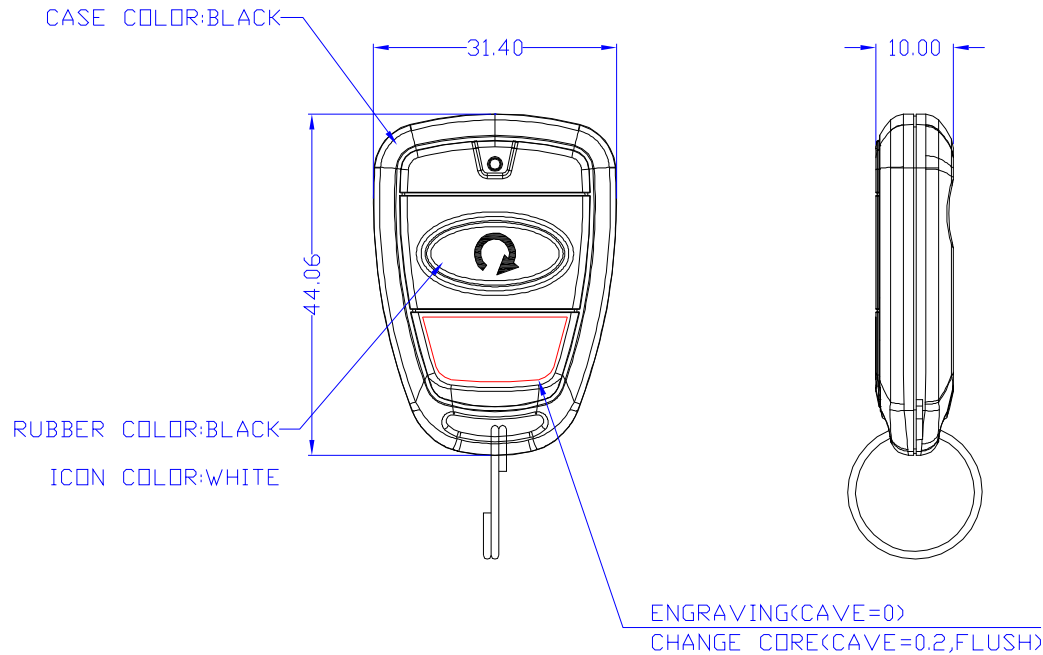

ENGRAVING (RAISED=0.2mm)
 CHANGE CORE(CAVE=0.2,TEXTURE MT-11020)

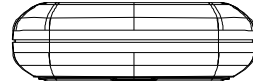
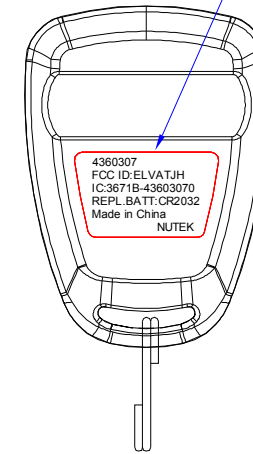

PART	P/N
CASE	IAAJ7001
TOP KEY	NKAJ70B0
KEY CHAIN	MA150000
BATTERY	CR2032

P/N: IAAJ7001

BODY MATERIAL : ABS+PC
 1. Texture is same as MT-11020
 2. Radius will be 0.2 if not specified.

*Tolerance please refer specification of tolerance limits "c"
 INJECT TOLERANCE SPEC.

GRADE	INJECT TOLERANCE SPEC.		
	A	B	C
UNDER 6	±0.08	±0.16	±0.30
6~30	±0.10	±0.20	±0.40
30~120	±0.20	±0.40	±0.80
120~300	±0.40	±0.80	±2.00

SCALE:	UNIT:	DRN BY	DATE	NUTEK CORPORATION			
1:1	M/M	DANIEL	2011/01/18	TITLE CSI OE 1-BTN TX			
MATERIAL		CHK BY		4360307			
FINISH		APPD BY		SIZE	DEPT	DRAWING NO	REV
CODE		SHEET	OF	A4		98I0340-1	0

REVISIONS				
REV.	ACC.	DESCRIPTION	DRN.	DATE
△	mail:2/23	modify changecore	DANIEL	2011/2/23

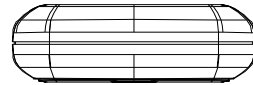

CASE COLOR:BLACK

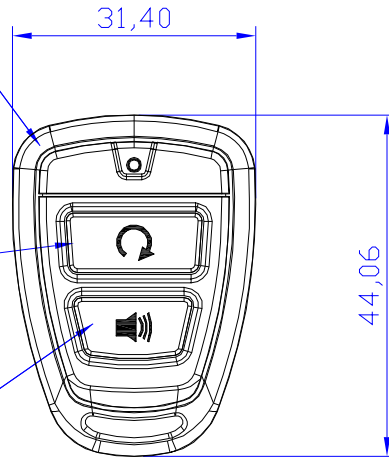

10,00

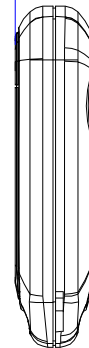

RUBBER COLOR:BLACK

ICON COLOR:WHITE

RUBBER COLOR:RED(#200C)

ICON COLOR:WHITE

ENGRAVING (RAISED=0.2mm)

CHANGE CORE(CAVE=0.2,TEXTURE MT-11020)

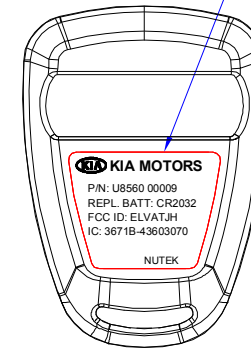

PART	P/N
CASE	IAAL0002
TOP KEY	NKAL00A0
KEY CHAIN	MA150000
BATTERY	CR2032

P/N: IAAL0002

BODY MATERIAL : ABS+PC

1. Texture is same as MT-11020
2. Radius will be 0.2 if not specified.

*Tolerance please refer specification of tolerance limits "c"
INJECT TOLERANCE SPEC.

GRADE	A	B	C
UNDER 6	± 0.08	± 0.16	± 0.30
6~30	± 0.10	± 0.20	± 0.40
30~120	± 0.20	± 0.40	± 0.80
120~300	± 0.40	± 0.80	± 2.00

SCALE:	UNIT:	DRN BY	DATE	NUTEK CORPORATION			
1:1	M/M	DANIEL	2011/02/11	TITLE CSI OE 2-BTN TX			
MATERIAL	CHK BY	YYS		4360317 KIA MOTORS			
FINISH	APPD BY	Victor		SIZE	DEPT	DRAWING NO	REV
CODE	SHEET	OF		A4		100I0030-2	1

REVISIONS				
REV.	ACC.	DESCRIPTION	DRN.	DATE
△	mail:2/23	modify changecore	DANIEL	2011/2/23

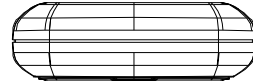

CASE COLOR:BLACK

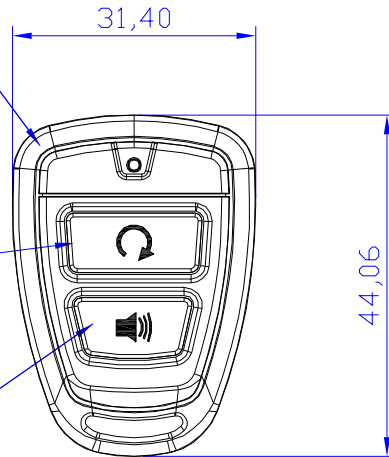

10,00

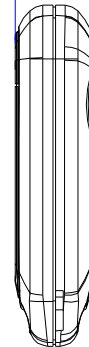

RUBBER COLOR:BLACK

ICON COLOR:WHITE

RUBBER COLOR:RED(#200C)

ICON COLOR:WHITE

ENGRAVING (RAISED=0.2mm)

CHANGE CORE(CAVE=0.2,TEXTURE MT-11020)

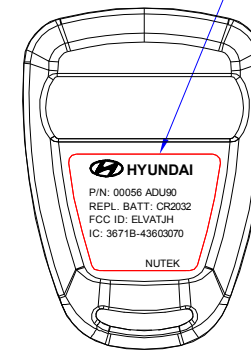

PART	P/N
CASE	IAAL0001
TOP KEY	NKAL00A0
KEY CHAIN	MA150000
BATTERY	CR2032

P/N: IAAL0001

BODY MATERIAL : ABS+PC
 1. Texture is same as MT-11020
 2. Radius will be 0.2 if not specified.

*Tolerance please refer specification of tolerance limits "c"
 INJECT TOLERANCE SPEC.

GRADE	A	B	C
UNDER 6	± 0.08	± 0.16	± 0.30
6~30	± 0.10	± 0.20	± 0.40
30~120	± 0.20	± 0.40	± 0.80
120~300	± 0.40	± 0.80	± 2.00

SCALE:	UNIT:	DRN BY	DATE	NUTEK CORPORATION			
1:1	M/M	DANIEL	2011/02/11	TITLE CSI OE 2-BTN TX			
MATERIAL		CHK BY		4360318 HYUNDAI			
FINISH		APPD BY		SIZE	DEPT	DRAWING NO	REV
CODE		SHEET	OF	A4		100I0030-1	1