



**EMC Technologies Pty Ltd**  
ABN 82 057 105 549  
176 Harrick Road  
Keilor Park  
Victoria Australia 3042

Ph: + 613 9365 1000  
Fax: + 613 9331 7455  
email: melb@emctech.com.au

## SAR Test Report

Report Number: M110325\_FCC\_WLU5110-D50(ROHS)\_SAR\_2.4

Test Sample: Portable TABLET Computer  
Radio Modules: WLAN RALINK WLU5110-D50(ROHS) & Bluetooth  
BCM92070MD\_REF6

Host PC Model Number: Q550

WLAN FCC ID: EJE-WL0025

WLAN IC: 337J-WL0025

Date of Issue: 7<sup>th</sup> April 2011

EMC Technologies Pty Ltd reports apply only to the specific samples tested under stated test conditions. It is the manufacturer's responsibility to assure that additional production units of this model are manufactured with identical electrical and mechanical components. EMC Technologies Pty Ltd shall have no liability for any deductions, inferences or generalisations drawn by the client or others from EMC Technologies Pty Ltd issued reports. This report shall not be used to claim, constitute or imply product endorsement by EMC Technologies Pty Ltd.



This document must not be copied or reproduced, except in full without the written permission of the Manager, EMC Technologies Pty Ltd. The certificate on page 3 may be reproduced in full.  
[www.emctech.com.au](http://www.emctech.com.au)



## CONTENTS

<b>1.0 GENERAL INFORMATION .....</b>	<b>3</b>
<b>2.0 INTRODUCTION .....</b>	<b>4</b>
<b>3.0 TEST SAMPLE TECHNICAL INFORMATION .....</b>	<b>4</b>
3.1 EUT (WLAN) Details .....	4
3.2 EUT (Bluetooth) Details .....	7
3.4 Test sample Accessories .....	8
3.4.1 Battery Types .....	8
<b>4.0 TEST SIGNAL, FREQUENCY AND OUTPUT POWER .....</b>	<b>9</b>
4.1 Battery Status .....	9
<b>5.0 DETAILS OF TEST LABORATORY .....</b>	<b>10</b>
5.1 Location .....	10
5.2 Accreditations .....	10
5.3 Environmental Factors .....	10
<b>6.0 DESCRIPTION OF SAR MEASUREMENT SYSTEM.....</b>	<b>11</b>
6.1 Probe Positioning System.....	11
6.2 E-Field Probe Type and Performance .....	11
6.4 System verification.....	11
6.4.1 System verification Results @ 2450MHz.....	11
6.4.2 Deviation from reference system verification values .....	11
6.4.3 Liquid Depth 15cm .....	12
6.5 Phantom Properties .....	12
6.6 Tissue Material Properties .....	13
6.6.1 Liquid Temperature and Humidity.....	13
6.7 Simulated Tissue Composition Used for SAR Test.....	13
6.8 Device Holder for Laptops and P 10.1 Phantom .....	13
<b>7.0 SAR MEASUREMENT PROCEDURE USING DASY5.....</b>	<b>14</b>
<b>8.0 MEASUREMENT UNCERTAINTY .....</b>	<b>15</b>
<b>9.0 EQUIPMENT LIST AND CALIBRATION DETAILS.....</b>	<b>17</b>
<b>10.0 TEST METHODOLOGY .....</b>	<b>18</b>
10.1 Positions .....	18
10.1.1 "Lap Held" Position Definition (0mm spacing) .....	18
10.1.2 "Edge On" Position (Portrait or Landscape).....	18
10.2 List of All Test Cases (Antenna In/Out, Test Frequencies, User Modes).....	18
<b>11.0 SAR MEASUREMENT RESULTS .....</b>	<b>19</b>
11.1 2450MHz SAR Results .....	19
<b>12.0 COMPLIANCE STATEMENT .....</b>	<b>20</b>
<b>13.0 MULTIBAND EVALUATION CONSIDERATIONS .....</b>	<b>21</b>
<b>APPENDIX A1 TEST SAMPLE PHOTOGRAPHS .....</b>	<b>22</b>
<b>APPENDIX A2 TEST SAMPLE PHOTOGRAPHS .....</b>	<b>23</b>
<b>APPENDIX A3 TEST SAMPLE PHOTOGRAPHS .....</b>	<b>24</b>
<b>APPENDIX A4 TEST SETUP PHOTOGRAPHS .....</b>	<b>25</b>
<b>APPENDIX A5 TEST SETUP PHOTOGRAPHS .....</b>	<b>26</b>
<b>APPENDIX B PLOTS OF THE SAR MEASUREMENTS .....</b>	<b>27</b>
<b>APPENDIX C CALIBRATION DOCUMENTS.....</b>	<b>42</b>



**SAR TEST REPORT****Report Number: M110325\_FCC\_WLU5110-D50(ROHS)\_SAR\_2.4****WLAN FCC ID:** EJE-WL0025**WLAN IC:** 337J-WL0025**1.0 GENERAL INFORMATION**

Table 1

<b>Test Sample:</b>	Portable TABLET Computer
<b>Model Name:</b>	Q550
<b>Radio Modules:</b>	WLAN WLU5110-D50(ROHS) & Bluetooth BCM92070MD_REF6
<b>Interface Type:</b>	Half Mini-PCI Module
<b>Device Category:</b>	Portable Transmitter
<b>Test Device:</b>	Pre-Production Unit
<b>WLAN FCC ID:</b>	<u>EJE-WL0025</u>
<b>WLAN IC:</b>	<u>337J-WL0025</u>
<b>RF exposure Category:</b>	General Population/Uncontrolled
<b>Manufacturer:</b>	Fujitsu Limited
<b>Test Standard/s:</b>	<ol style="list-style-type: none"> <li>1. Evaluating Compliance with FCC Guidelines For Human Exposure to Radiofrequency Electromagnetic Fields Supplement C (Edition 01-01) to OET Bulletin 65 (Edition 97-01)</li> <li>2. Radio Frequency Exposure Compliance of Radiocommunication Apparatus (All Frequency Bands), RSS-102</li> </ol>
<b>Statement Of Compliance:</b>	The Fujitsu TABLET Computer Q550 with Wireless LAN model WLU5110-D50(ROHS) and Bluetooth module BCM92070MD_REF6 complied* with the FCC General public/uncontrolled RF exposure limits of 1.6mW/g per requirements of 47CFR2.1093(d). It also complied with IC RSS-102 requirements.
<b>Test Dates:</b>	5 <sup>th</sup> April 2011
<b>Test Officer:</b>	 <b>Peter Jakubiec</b>
<b>Authorised Signature:</b>	 <hr/> <b>Chris Zombolas</b> <b>Technical Director</b>

This document is issued in accordance with NATA's accreditation requirements. The results of tests, calibration and/or measurements included in this document are traceable to Australian/national standards. NATA is a signatory to the ILAC Mutual Recognition Arrangement for the mutual recognition of the equivalence of testing and calibration reports.



**SAR TEST REPORT**  
**Portable TABLET Computer**  
**Model: Q550**  
**Report Number: M110325\_FCC\_WLU5110-D50(ROHS)\_SAR\_2.4**

## 2.0 INTRODUCTION

Testing was performed on the Ralink 802.11abgn Wireless LAN Module, Model: WLU5110-D50(ROHS) installed in the Fujitsu STYLISTIC Q Series, Model number: Q550. The RALINK module is an OEM product. The system tested will be referred to as the DUT throughout this report.

The Fujitsu Tablet PC, Model: Q550 is equipped with a Bluetooth transmitter and Bluetooth antenna. The bluetooth module is a Broadcom Bluetooth Module, Model: BCM92070MD\_REF6. The Bluetooth module was originally certified by Broadcom as a modular approval under FCC ID: QDS-BRCM1043 (Canada ID: 4324A-BRCM1043). Stand-alone SAR was not required for the Bluetooth due to the low power output. The Bluetooth module was not assessed for co-location because the WLAN and Bluetooth antennas are >5cms apart.

The measurement test results mentioned herein only apply to the 2450MHz frequency band; an additional report titled "M110325\_FCC\_WLU5110-D50(ROHS)\_SAR\_5.6" applies to the 5GHz range.

## 3.0 TEST SAMPLE TECHNICAL INFORMATION

(Information supplied by the client)

### 3.1 DUT (WLAN) Details

Table 2

<b>Transmitter:</b>	Mini-Card Wireless LAN Module
<b>FCC ID:</b>	<b>EJE-WL0025</b>
<b>IC:</b>	<b>337J-WL0025</b>
<b>Wireless Module:</b>	RALINK (802.11a/b/g/n)
<b>Model Number:</b>	WLU5110-D50(ROHS)
<b>Manufacturer:</b>	RALINK Corporation
<b>Modulation Type:</b>	Direct Sequence Spread Spectrum (DSSS for 802.11b) Orthogonal Frequency Division Multiplexing (OFDM for 802.11g) Orthogonal Frequency Division Multiplexing (OFDM for 802.11a) Orthogonal Frequency Division Multiplexing (OFDM for 802.11n)
<b>2.4 GHz (802.11b/g/n):</b>	DBPSK, DQPSK, CCK, 16QAM and 64QAM
<b>5 GHz (802.11a/n):</b>	BPSK, QPSK, 16QAM and 64QAM
<b>Maximum Data Rate:</b>	802.11b = 11Mbps, 802.11g and 802.11a = 54Mbps 802.11n = 300 Mbps
<b>Frequency Ranges:</b>	2.412 –2.462 GHz for 11b/g/n 5.18 - 5.32 GHz and 5.745 - 5.825 GHz for 11a/n
<b>Number of Channels:</b>	11 channels for 11b/g/n 24 channels for 11a/n with 20 MHz bandwidth 18 channels for 11n with 40 MHz bandwidth
<b>Antenna Types:</b>	Nissei Electric Inverted F Antenna Model: refer to WLAN antenna data Location: Top edge of LCD screen
<b>Power Supply:</b>	3.3 VDC from PCI bus



Accreditation No. 5292

Table 3 Channels and Output power setting

Mode	Channel	Frequency (MHz)	Data Rate (Mbps)	Tx BW (MHz)	Average Power Target (dBm)
802.11a	36	5180	6	-	13
	40	5200			
	44	5220			
	48	5240			
	52	5260			
	56	5280			
	60	5300			
	64	5320			
	100	5500			
	104	5520			
	108	5540			
	112	5560			
	116	5580			
	120	5600			
	124	5620			
	128	5640			
	132	5660			
	136	5680			
	140	5700			
	149	5745			12
153	5765				
157	5785				
161	5805				
165	5825				
802.11b	1	2412	1	-	16
	6	2437			
	11	2462			
	13	2472			
802.11g	1	2412	6	-	15
	2	2417			
	6	2437			
	10	2457			
	11	2462			
	13	2472			



Mode	Channel	Frequency (MHz)	Data Rate (Mbps)	Tx BW (MHz)	Average Power Target (dBm)
802.11n	1	2412	HT0	20	13
	2	2417			
	6	2437			
	10	2457			
	11	2462			
	13	2472			
	36	5180			
	40	5200			
	44	5220			
	48	5240			
	52	5260			
	56	5280			
	60	5300			
	64	5320			
	100	5500			
	104	5520			
	108	5540			
	112	5560			
	116	5580			
	120	5600			
	124	5620			
	128	5640			
	132	5660			
	136	5680			
	140	5700			
	149	5745			
	153	5765			
	157	5785			
	161	5805			
	165	5825			
	3F	2422		40 Wide	15
	4F	2427			
	5F	2432			
	6F	2437			
	7F	2442			
	8F	2447			
9F	2452				
38	5190	13			
46	5230				
54	5270				
62	5310				
102	5510				
110	5550				
118	5590				
126	5630				
134	5670				
151	5755				
159	5795				

NOTE: For 5GHz SAR results refer to report titled "M110325\_FCC\_WLU5110-D50(ROHS)\_SAR\_5.6".



### 3.2 DUT (Bluetooth) Details

Table 4

<b>Transmitter:</b>	Bluetooth
<b>FCC ID:</b>	<b>QDS-BRCM1043</b>
<b>IC:</b>	<b>4324A-BRCM1043</b>
<b>Model Number:</b>	BCM92070MD_REF6
<b>Manufacturer:</b>	BROADCOM
<b>Network Standard:</b>	Bluetooth™ RF Test Specification
<b>Modulation Type:</b>	Frequency Hopping Spread Spectrum (FHSS)
<b>Frequency Range:</b>	2402 MHz to 2480 MHz
<b>Number of Channels:</b>	79
<b>Carrier Spacing:</b>	1.0 MHz
<b>Antenna Types:</b>	Monopole Antenna included in module Module location: right upper corner
<b>Max. Output Power:</b>	4 dBm
<b>Reference Oscillator:</b>	16 MHz (Built-in)
<b>Power Supply:</b>	3.3 VDC from host.

Table 5

Channel Number	Frequency (MHz)	Bluetooth Utility power setting
1	2402	Power (Ext, Int) = 0, 96
2	2403	
-	-	
39	2440	
40	2441	
41	2442	
-	-	
78	2479	
79	2480	



### 3.3 DUT (Notebook PC) Details

**Table 6**

<b>EUT:</b>	STYLISTIC Q SERIES
<b>Model Number:</b>	Q550
<b>Serial Number:</b>	Pre-production Sample
<b>Manufacturer:</b>	FUJITSU LIMITED
<hr/>	
<b>CPU Type and Speed:</b>	Atom Z670 1.5GHz
<b>LCD</b>	10.1" WXGA (1280x800)
<b>Wired LAN:</b>	Non
<b>Modem:</b>	Non
<b>Port Replicator Model:</b>	FPCPR114
<hr/>	
<b>AC Adapter Model:</b>	80W: SEE55N2-19.0(Sanken)
<b>Voltage:</b>	19 V
<b>Current Specs:</b>	2.1A
<b>Watts:</b>	40W
<b>Radio Modules:</b>	WLAN (IEEE802.11a/b/g/n, 1x1)
<b>WLAN Model Number:</b>	WLU5110-D50(ROHS)
<b>WLAN Manufacturer:</b>	Ralink.
<b>Interface Type:</b>	USB
<b>Radio Modules:</b>	Bluetooth module
<b>Model Number:</b>	BCM92070MD_REF6
<b>Manufacturer:</b>	Broadcom
<b>Interface Type:</b>	USB

### 3.4 Test sample Accessories

#### 3.4.1 Battery Types

One type of Fujitsu Lithium Ion battery is used to power the DUT.

**Table 7 Battery Details**

Model	LIP4132FTPC(SY6)
V/mAh	7.2V/5240mAh





## 4.0 TEST SIGNAL, FREQUENCY AND OUTPUT POWER

Ralink QA test tool was used to configure the WLAN for testing. The DUT Wireless LAN had a total of 11 channels (USA model) within the 2412 to 2462 MHz frequency band and 24 channels within the frequency range 5180 to 5825 MHz. In The frequency range 2412 MHz to 2462 MHz the DUT operates in 2 modes, OFDM and DSSS. Within the 5180 to 5825 MHz frequency range the device operates in OFDM mode only. For the SAR measurements the device was operating in continuous transmit mode using programming codes supplied by Fujitsu.

The Bluetooth module operates over 79 channels within the frequency range 2402 to 2480 MHz. It is possible for the Bluetooth module to operate simultaneously with the WLAN module (co-transmission). However, due to low output power of Bluetooth module (less than 5mW), standalone SAR measurement for Bluetooth module was not conducted (as per **KDB 616217**). The Bluetooth interface utilizes dedicated antenna, for the purpose of this report labelled antenna "D".

The test results mentioned in this report only apply to the 2450MHz frequency range. An additional report titled "M110325\_FCC\_WLU5110-D50(ROHS)\_SAR\_5.6" is specific to the 5GHz range.

The WLAN modules can be configured in a number of different data rates. It was found that the highest source based time averaged power was measured when using the lowest data rates available in each mode. This lowest data rate corresponds to 6Mbps in OFDM mode and 1Mbps in DSSS mode.

The frequency span of the 2450 MHz range Band was more than 10MHz consequently; the SAR levels of the test sample were measured for lowest, centre and highest channels in the applicable modes. There were no wires or other connections to the DUT during the SAR measurements.

At the beginning of the SAR tests, the conducted power of the device was measured after temporary modification of antenna connector inside the device's TX RX compartment. Measurements were performed with a calibrated Power Meter. The Transmitter power was set to be equal or higher than power specified by the manufacturer.

### 4.1 Battery Status

The device battery was fully charged prior to commencement of measurement. Each SAR test was completed within 30 minutes. The battery condition was monitored by measuring the RF field at a defined position inside the phantom before the commencement of each test and again after the completion of the test. It was not possible to perform conducted power measurements at the output of the device, at the beginning and end of each scan due to lack of a suitable antenna port. The uncertainty associated with the power drift was less than 12% and was assessed in the uncertainty budget.



## 5.0 DETAILS OF TEST LABORATORY

### 5.1 Location

EMC Technologies Pty Ltd  
176 Harrick Road  
Keilor Park, (Melbourne) Victoria  
Australia 3042

**Telephone:** +61 3 9365 1000  
**Facsimile:** +61 3 9331 7455  
**email:** [melb@emctech.com.au](mailto:melb@emctech.com.au)  
**website:** [www.emctech.com.au](http://www.emctech.com.au)

### 5.2 Accreditations

EMC Technologies Pty. Ltd. is accredited by the National Association of Testing Authorities, Australia (NATA).  
**NATA Accredited Laboratory Number: 5292**

EMC Technologies Pty Ltd is NATA accredited for the following standards:

**Table 8**

<b>AS/NZS 2772.2:</b>	RF and microwave radiation hazard measurement
<b>ACMA:</b>	Radio communications (Electromagnetic Radiation - Human Exposure) Standard 2003 + Amdt (No. 2):2011
<b>FCC:</b>	Guidelines for Human Exposure to RF Electromagnetic Field OET65C 01/01
<b>EN 50360: 2001</b>	Product standard to demonstrate the compliance of mobile phones with the basic restrictions related to human exposure to electromagnetic fields (300 MHz – 3 GHz)
<b>EN 62209-1:2006</b>	Human Exposure to radio frequency fields from hand-held and body-mounted wireless communication devices - Human models instrumentation and procedures. <b>Part 1:</b> Procedure to determine the specific absorption rate (SAR) for hand-held devices used in close proximity to the ear (300 MHz to 3 GHz)
<b>*EN62209-2:2010</b>	Human Exposure to radio frequency fields from hand-held and body-mounted wireless communication devices - Human models instrumentation and procedures <b>Part 2:</b> Procedure to determine the specific absorption rate (SAR) for wireless communication devices used in close proximity to the human body (frequency range of 30 MHz to 6 GHz)
<b>IEEE 1528: 2003</b>	Recommended Practice for Determining the Peak Spatial-Average Specific Absorption Rate (SAR) in the Human Head Due to Wireless Communications Devices: Measurement Techniques.

\*NATA accreditation pending – standard to be adopted by ACMA.

Refer to NATA website [www.nata.asn.au](http://www.nata.asn.au) for the full scope of accreditation.

### 5.3 Environmental Factors

The measurements were performed in a shielded room with no background RF signals. The temperature in the laboratory was controlled to within  $20 \pm 1^\circ\text{C}$ , the humidity was 52%. The liquid parameters are measured daily prior to the commencement of each test. Tests were performed to check that reflections within the environment did not influence the SAR measurements. The noise floor of the DASY5 SAR measurement system using the SN1380 probe was less than  $5\mu\text{V}$  in both air and liquid mediums.



## 6.0 DESCRIPTION OF SAR MEASUREMENT SYSTEM

Table 9

Applicable Head Configurations	: None
Applicable Body Configurations	: Lap Held Position : Edge On Position

### 6.1 Probe Positioning System

The measurements were performed with the state-of-the-art automated near-field scanning system **DASY5 V52** from Schmid & Partner Engineering AG (SPEAG). The DASY5 fully complies with the OET65 C (01-01), IEEE 1528 and EN62209-1 and EN62209-2 SAR measurement requirements.

### 6.2 E-Field Probe Type and Performance

The SAR measurements were conducted with SPEAG dosimetric probe ET3DV6 Serial: 1380 (2.45 GHz). Please refer to appendix C for detailed information.

### 6.4 System verification

#### 6.4.1 System verification Results @ 2450MHz

The following tables lists the dielectric properties of the tissue simulating liquid measured prior to SAR system verification. The results of the system verification are listed in columns 4 and 5. The forward power into the reference dipole for SAR system verification was adjusted to 250 mW.

Table 10 System verification Results (Dipole: SPEAG D2450V2 SN: 724)

1. System Frequency and verification Date	2. $\epsilon_r$ (measured)	3. $\sigma$ (mho/m) (measured)	4. Measured SAR 1g (mW/g)	5. Measured SAR 10g (mW/g)
5 <sup>th</sup> April 2011	51.5	1.94	14.7	6.95

#### 6.4.2 Deviation from reference system verification values

The reference SAR values are derived using a reference dipole and flat section of the SAM phantom suitable for a centre frequency of 2450MHz. These reference SAR values are obtained from the IEEE Std 1528-2003 and are normalized to 1W.

The SPEAG calibration reference SAR value is the SAR system verification result obtained in a specific dielectric liquid using the validation dipole (D2450V2) during calibration. The measured one-gram SAR should be within 10% of the expected target reference values shown in table below (2450MHz) below.

Table 11 Deviation from reference system verification values @ 2450MHz

Frequency and Date	Measured SAR 1g (mW/g)	Measured SAR 1g (Normalized to 1W)	SPEAG Calibration reference SAR Value 1g (mW/g)	Deviation From SPEAG Reference 1g (%)
2450MHz 5 <sup>th</sup> April 2011	14.7	58.80	60	-2.00

NOTE: All reference system verification values are referenced to 1W input power.



### 6.4.3 Liquid Depth 15cm

During the SAR measurement process the liquid level was maintained to a level of 15cm with a tolerance of 0.5cm.

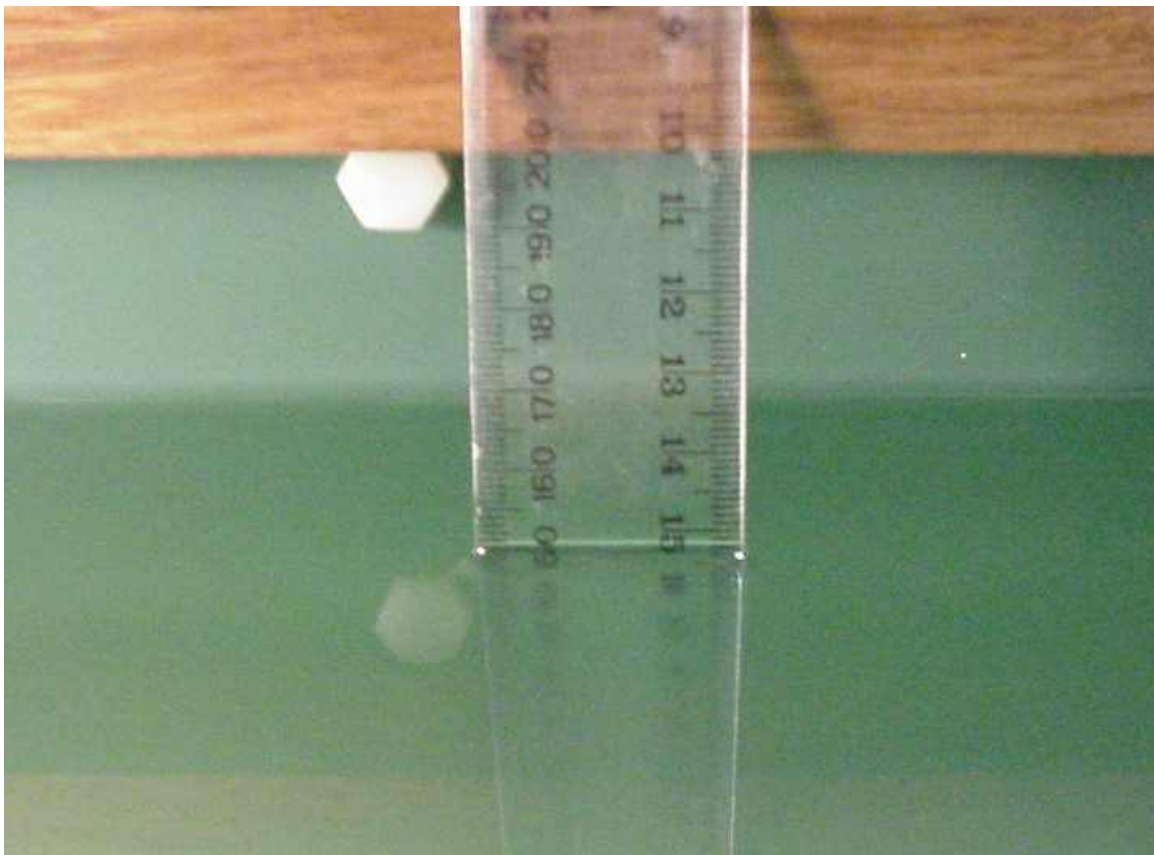

Photo of liquid Depth in Flat Phantom

### 6.5 Phantom Properties

The phantoms used during the testing comply with the OET65 C (01-01), IEEE 1528 and EN62209-1 and EN62209-2 SAR measurement requirements.

## 6.6 Tissue Material Properties

The dielectric parameters of the brain simulating liquid were measured prior to SAR assessment using the HP85070A dielectric probe kit and HP8753ES Network Analyser. The actual dielectric parameters are shown in the following table.

**Table 12 Measured Brain Simulating Liquid Dielectric Values for System verifications**

Frequency Band	$\epsilon_r$ (measured range)	$\epsilon_r$ (target)	$\sigma$ (mho/m) (measured range)	$\sigma$ (target)	$\rho$ kg/m <sup>3</sup>
2450 MHz Muscle	51.5	52.7 $\pm$ 5% (50.1 to 55.3)	1.94	1.95 $\pm$ 5% (1.85 to 2.05)	1000

NOTE: The body liquid parameters were within the required tolerances of  $\pm$ 5%.

**Table 13 Measured Body Simulating Liquid Dielectric Values**

Frequency Band	$\epsilon_r$ (measured range)	$\epsilon_r$ (target)	$\sigma$ (mho/m) (measured range)	$\sigma$ (target)	$\rho$ kg/m <sup>3</sup>
2412 MHz Muscle	51.7	52.7 $\pm$ 5% (50.1 to 55.3)	1.89	1.95 $\pm$ 5% (1.85 to 2.05)	1000
2437 MHz Muscle	51.6	52.7 $\pm$ 5% (50.1 to 55.3)	1.92	1.95 $\pm$ 5% (1.85 to 2.05)	1000
2462 MHz Muscle	51.4	52.7 $\pm$ 5% (50.1 to 55.3)	1.96	1.95 $\pm$ 5% (1.85 to 2.05)	1000

NOTE: The brain and muscle liquid parameters were within the required tolerances of  $\pm$ 5%.

### 6.6.1 Liquid Temperature and Humidity

The humidity and dielectric/ambient temperatures were recorded during the assessment of the tissue material dielectric parameters. The difference between the ambient temperature of the liquid during the dielectric measurement and the temperature during tests was less than  $|2|^\circ\text{C}$ .

**Table 14 Temperature and Humidity recorded for each day**

Date	Ambient Temperature ( $^\circ\text{C}$ )	Liquid Temperature ( $^\circ\text{C}$ )	Humidity (%)
5 <sup>th</sup> April 2011	20.8	20.5	52

## 6.7 Simulated Tissue Composition Used for SAR Test

The tissue simulating liquids are created prior to the SAR evaluation and often require slight modification each day to obtain the correct dielectric parameters.

**Table 15 Tissue Type: Muscle @ 2450MHz**

Volume of Liquid: 60 Litres

Approximate Composition	% By Weight
Distilled Water	73.2
Salt	0.04
DGBE	26.7

\*Refer "OET Bulletin 65 97/01 P38"

## 6.8 Device Holder for Laptops and P 10.1 Phantom

A low loss clamp was used to position the DUT underneath the phantom surface.

Refer to Appendix A for photographs of device positioning



## 7.0 SAR MEASUREMENT PROCEDURE USING DASY5

The SAR evaluation was performed with the SPEAG DASY5 system. A summary of the procedure follows:

- a) A measurement of the SAR value at a fixed location is used as a reference value for assessing the power drop of the EUT. The SAR at this point is measured at the start of the test, and then again at the end of the test.
- b) The SAR distribution at the exposed flat section of the flat phantom is measured at a distance of 4 mm from the inner surface of the shell. The area covers the entire dimension of the EUT and the horizontal grid spacing is 15 mm x 15 mm. The actual Area Scan has dimensions of 75 mm x 120 mm surrounding the test device. Based on this data, the area of the maximum absorption is determined by Spline interpolation.
- c) Around this point, a volume of 30 mm x 30 mm x 30 mm is assessed by measuring 7 x 7 x 7 points. On the basis of this data set, the spatial peak SAR value is evaluated with the following procedure:
  - (i) The data at the surface are extrapolated, since the centre of the dipoles is 2.7 mm away from the tip of the probe and the distance between the surface and the lowest measuring point is 4 mm. The extrapolation is based on a least square algorithm. A polynomial of the fourth order is calculated through the points in z-axes. This polynomial is then used to evaluate the points between the surface and the probe tip.
  - (ii) The maximum interpolated value is searched with a straightforward algorithm. Around this maximum the SAR values averaged over the spatial volumes (1 g and 10 g) are computed using the 3D-Spline interpolation algorithm. The 3D-Spline is composed of three one-dimensional splines with the "Not a knot"- condition (in x, y and z-direction). The volume is integrated with the trapezoidal – algorithm. One thousand points (10 x 10 x 10) are interpolated to calculate the averages.
  - (iii) All neighbouring volumes are evaluated until no neighbouring volume with a higher average value is found.
  - (iv) The SAR value at the same location as in Step (a) is again measured to evaluate the actual power drift.





### 8.0 MEASUREMENT UNCERTAINTY

The uncertainty analysis is based on the template listed in the IEEE Std 1528-2003 for both device SAR tests and System verification uncertainty. The measurement uncertainty of a specific device is evaluated independently and the total uncertainty for both evaluations (95% confidence level) must be less than 30%.

**Table 16 Uncertainty Budget for DASY5 V52 – DUT SAR test 2450MHz**

Error Description	Uncert. Value	Prob. Dist.	Div.	C <sub>i</sub> (1g)	C <sub>i</sub> (10g)	1g u <sub>i</sub>	10g u <sub>i</sub>	v <sub>i</sub>
<b>Measurement System</b>								
Probe Calibration	5.5	N	1.00	1	1	5.50	5.50	∞
Axial Isotropy	4.7	R	1.73	0.7	0.7	1.90	1.90	∞
Hemispherical Isotropy	9.6	R	1.73	0.7	0.7	3.88	3.88	∞
Boundary Effects	1	R	1.73	1	1	0.58	0.58	∞
Linearity	4.7	R	1.73	1	1	2.71	2.71	∞
System Detection Limits	1	R	1.73	1	1	0.58	0.58	∞
Readout Electronics	0.3	N	1.00	1	1	0.30	0.30	∞
Response Time	0.8	R	1.73	1	1	0.46	0.46	∞
Integration Time	2.6	R	1.73	1	1	1.50	1.50	∞
RF Ambient Noise	3	R	1.73	1	1	1.73	1.73	∞
RF Ambient Reflections	3	R	1.73	1	1	1.73	1.73	∞
Probe Positioner	0.4	R	1.73	1	1	0.23	0.23	∞
Probe Positioning	2.9	R	1.73	1	1	1.67	1.67	∞
Max. SAR Eval.	1	R	1.73	1	1	0.58	0.58	∞
<b>Test Sample Related</b>								
Test Sample Positioning	2.9	N	1.00	1	1	2.90	2.90	145
Device Holder Uncertainty	3.6	N	1.00	1	1	3.60	3.60	5
Output Power Variation – SAR Drift Measurement	7.96	R	1.73	1	1	4.59	4.59	∞
<b>Phantom and Setup</b>								
Phantom Uncertainty	4	R	1.73	1	1	2.31	2.31	∞
Liquid Conductivity – Deviation from target values	5	R	1.73	0.64	0.43	1.85	1.24	∞
Liquid Conductivity – Measurement uncertainty	2.5	N	1.00	0.64	0.43	1.60	1.08	∞
Liquid Permittivity – Deviation from target values	5	R	1.73	0.6	0.49	1.73	1.41	∞
Liquid Permittivity – Measurement uncertainty	2.5	N	1.00	0.6	0.49	1.50	1.23	∞
Combined standard Uncertainty (u <sub>c</sub> )						11.3	11.1	
Expanded Uncertainty (95% CONFIDENCE LEVEL)			k=	2		22.6	22.2	

Estimated total measurement uncertainty for the DASY5 measurement system was ±11.3%. The extended uncertainty (K = 2) was assessed to be ±22.6% based on 95% confidence level. The uncertainty is not added to the measurement result.

**Table 17 Uncertainty Budget for DASY5 V52 – System verification 2450MHz**



Error Description	Uncert. Value	Prob. Dist.	Div.	C <sub>i</sub> (1g)	C <sub>i</sub> (10g)	1g u <sub>i</sub>	10g u <sub>i</sub>	v <sub>i</sub>
<b>Measurement System</b>								
Probe Calibration	5.5	N	1.00	1	1	5.50	5.50	∞
Axial Isotropy	4.7	R	1.73	1	1	2.71	2.71	∞
Hemispherical Isotropy	9.6	R	1.73	0	0	0.00	0.00	∞
Boundary Effects	1	R	1.73	1	1	0.58	0.58	∞
Linearity	4.7	R	1.73	1	1	2.71	2.71	∞
System Detection Limits	1	R	1.73	1	1	0.58	0.58	∞
Readout Electronics	0.3	N	1.00	1	1	0.30	0.30	∞
Response Time	0	R	1.73	1	1	0.00	0.00	∞
Integration Time	0	R	1.73	1	1	0.00	0.00	∞
RF Ambient Noise	1	R	1.73	1	1	0.58	0.58	∞
RF Ambient Reflections	1	R	1.73	1	1	0.58	0.58	∞
Probe Positioner	0.8	R	1.73	1	1	0.46	0.46	∞
Probe Positioning	6.7	R	1.73	1	1	3.87	3.87	∞
Max. SAR Eval.	2	R	1.73	1	1	1.15	1.15	∞
<b>Dipole Related</b>								
Deviation of exp. dipole	5.5	R	1.73	1	1	3.18	3.18	∞
Dipole Axis to Liquid Dist.	2	R	1.73	1	1	1.15	1.15	∞
Input power & SAR drift	5.00	R	1.73	1	1	2.89	2.89	∞
<b>Phantom and Setup</b>								
Phantom Uncertainty	4	R	1.73	1	1	2.31	2.31	∞
SAR Correction	1.9	R	1.73	1	0.84	1.10	0.92	∞
Liquid Conductivity (meas.)	2.5	N	1.00	0.78	0.71	1.95	1.78	∞
Liquid Permittivity (meas.)	2.5	N	1.00	0.26	0.26	0.65	0.65	∞
Temp.unc. - Conductivity	1.7	R	1.73	0.78	0.71	0.77	0.70	∞
Temp. unc. - Permittivity	0.3	R	1.73	0.23	0.26	0.04	0.05	∞
Combined standard Uncertainty (u <sub>c</sub> )						9.7	9.6	
Expanded Uncertainty (95% CONFIDENCE LEVEL)			k= 2			19.4	19.3	

Estimated total measurement uncertainty for the DASY5 measurement system was ±9.7%. The extended uncertainty (K = 2) was assessed to be ±19.4% based on 95% confidence level. The uncertainty is not added to the System verification measurement result.





## 9.0 EQUIPMENT LIST AND CALIBRATION DETAILS

Table 18 SPEAG DASY5 Version 52

Equipment Type	Manufacturer	Model Number	Serial Number	Calibration Due	Used For this Test?
Robot - Six Axes	Staubli	RX90BL	N/A	Not applicable	✓
Robot Remote Control	SPEAG	CS7MB	RX90B	Not applicable	✓
SAM Phantom	SPEAG	N/A	1260	Not applicable	
SAM Phantom	SPEAG	N/A	1060	Not applicable	
Flat Phantom	AndreT	10.1	P 10.1	Not Applicable	✓
Flat Phantom	AndreT	9.1	P 9.1	Not Applicable	
Flat Phantom	SPEAG	PO1A 6mm	1003	Not Applicable	
Data Acquisition Electronics	SPEAG	DAE3 V1	359	07-July-2011	
Data Acquisition Electronics	SPEAG	DAE3 V1	442	09-Dec-2011	✓
Probe E-Field - Dummy	SPEAG	DP1	N/A	Not applicable	
Probe E-Field	SPEAG	ET3DV6	1380	09-Dec-2011	
Probe E-Field	SPEAG	ET3DV6	1377	7-July-2011	
Probe E-Field	SPEAG	ES3DV6	3029	Not Used	
Probe E-Field	SPEAG	EX3DV4	3563	16-July-2011	
Probe E-Field	SPEAG	EX3DV4	3657	13-Dec-2011	
Antenna Dipole 300 MHz	SPEAG	D300V2	1005	15-Dec-2011	
Antenna Dipole 450 MHz	SPEAG	D450V2	1009	17-Dec-2010	
Antenna Dipole 900 MHz	SPEAG	D900V2	047	5-July-2012	
Antenna Dipole 1640 MHz	SPEAG	D1640V2	314	9-July-2012	
Antenna Dipole 1800 MHz	SPEAG	D1800V2	242	13-July-2012	
Antenna Dipole 1950 MHz	SPEAG	D1950V3	1113	10-Dec -2012	
Antenna Dipole 3500 MHz	SPEAG	D3500V2	1002	17-July-2010	
Antenna Dipole 2450 MHz	SPEAG	D2450V2	724	09-Dec-2012	✓
Antenna Dipole 5600 MHz	SPEAG	D5GHzV2	1008	16-Dec-2011	✓
RF Amplifier	EIN	603L	N/A	*In test	
RF Amplifier	Mini-Circuits	ZHL-42	N/A	*In test	
RF Amplifier	Mini-Circuits	ZVE-8G	N/A	*In test	✓
Synthesized signal generator	Hewlett Packard	ESG-D3000A	GB37420238	*In test	
RF Power Meter	Hewlett Packard	437B	3125012786	9-Aug-2011	✓
RF Power Sensor 0.01 - 18 GHz	Hewlett Packard	8481H	1545A01634	13-Aug-2011	✓
RF Power Meter	Rohde & Schwarz	NRP	101415	5-May-2011	
RF Power Sensor	Rohde & Schwarz	NRP - Z81	100174	16-July-2011	
RF Power Meter Dual	Hewlett Packard	435A	1733A05847	*In test	✓
RF Power Sensor	Hewlett Packard	8482A	2349A10114	*In test	✓
Network Analyser	Hewlett Packard	8714B	GB3510035	22-Sept-2011	
Network Analyser	Hewlett Packard	8753ES	JP39240130	10-Nov-2011	✓
Dual Directional Coupler	Hewlett Packard	778D	1144 04700	*In test	
Dual Directional Coupler	NARDA	3022	75453	*In test	✓

\* Calibrated during the test for the relevant parameters.



## 10.0 TEST METHODOLOGY

Notebooks should be evaluated in normal use positions, typical for lap-held bottom-face only. However the number of positions will depend on the number of configurations the tablet can be operated in. The “STYLISTIC Q SERIES” PC can be used on the lap (see Appendix A1) or hand held as a Tablet PC. One WLAN antenna location in the “STYLISTIC Q SERIES” is closest to the bottom of the tablet and the other antenna location is closest to the screen of the tablet.

### 10.1 Positions

#### 10.1.1 “Lap Held” Position Definition (0mm spacing)

The DUT was tested in the 2.00 mm flat section of the AndreT Flat phantom P 10.1 for the “Lap Held” position. The Transceiver was placed at the bottom of the phantom and suspended in such way that the back of the DUT was touching the phantom. This device orientation simulates the PC’s normal use – being held on the lap of the user. A spacing of 0mm ensures that the SAR results are conservative and represent a worst-case position.

#### 10.1.2 “Edge On” Position (Portrait or Landscape)

The DUT was tested in the (2.00 mm) flat section of the AndreT phantom for the “Edge On” position. The Antenna edge of the Transceiver was placed underneath the flat section of the phantom and suspended until the edge touched the phantom. Refer to Appendix A for photos of measurement positions.

### 10.2 List of All Test Cases (Antenna In/Out, Test Frequencies, User Modes)

The DUT has a fixed antenna. Depending on the measured SAR level up to three test channels with the test sample operating at maximum power were recorded. The following table represents the matrix used to determine what testing was required. All relevant provisions of KDB 447498 are applied for SAR measurements of the host system.

Table 19 Testing configurations

Phantom Configuration	*Device Mode	Test Configurations		
		Channel (Low)	Channel (Middle)	Channel (High)
Lap Held	DSSS 2.4GHz		X	
Edge On	DSSS 2.4GHz		X	

Legend

X Testing Required in this configuration

Testing required in this configuration only if SAR of middle channel is more than 3dB below the SAR limit or it is the worst case.



## 11.0 SAR MEASUREMENT RESULTS

The SAR values averaged over 1g tissue masses were determined for the sample DUT for all test configurations listed in section 10.2.

### 11.1 2450MHz SAR Results

There are two modes of operation within the 2450MHz band, they include OFDM and DSSS modulations. Refer to section 10.2 for selection of all device test configurations. Table below displays the SAR results.

**Table 20 SAR MEASUREMENT RESULTS – DSSS Mode**

Test Position	Plot No.	Bit rate Mode (Mbps)	Channel Bandwidth (MHz)	Test Channel	Test Freq (MHz)	Measured 1g SAR Results (mW/g)	Measured Drift (dB)
Lap Held	1	1	-	01	2412	0.815	0.27
	2			06	2437	0.864	0.31
	3			011	2462	0.499	-0.14
Secondary Landscape	4	1	-	01	2412	0.545	-0.36
	5			06	2437	0.666	-0.07
	6			11	2462	<b>0.870</b>	-0.01

NOTE: The measurement uncertainty of 22.6% for 2.45GHz was not added to the result.

The highest SAR level recorded in the 2450MHz band was **0.870** mW/g as evaluated in a 1g cube of averaging mass. This value was obtained in **Secondary Landscape** position in **DSSS** mode, utilizing channel **11** (**2462** MHz)



## 12.0 COMPLIANCE STATEMENT

The Fujitsu TABLET PC, Model: Q550 with RALINK Mini-PCI Wireless LAN Module (RALINK 802.11a/b/g/n), Model: WLU5110-D50(ROHS) & BROADCOM Bluetooth Module, Model: BCM92070MD\_REF6 was found to comply with the FCC and RSS-102 SAR requirements.

The highest SAR level recorded was **0.870** mW/g for a 1g cube. This value was measured at **2462** MHz (channel 11) in the “**Secondary Landscape**” position in **DSSS** modulation mode. This was below the limit of 1.6 mW/g for uncontrolled exposure, even taking into account the measurement uncertainty of 22.6 %.

This document is issued in accordance with NATA's accreditation requirements. The results of tests, calibration and/or measurements included in this document are traceable to Australian/national standards. NATA is a signatory to the ILAC Mutual Recognition Arrangement for the mutual recognition of the equivalence of testing and calibration reports.



### 13.0 MULTIBAND EVALUATION CONSIDERATIONS

Fujitsu **TABLET PC**, Model: **Q550** is equipped with WLAN WLU5110-D50(ROHS) and Bluetooth (BCM92070MD\_REF6).

According to the FCC SAR evaluation procedures mentioned in **KDB 616217**, stand-alone SAR evaluation is NOT required when the maximum transmitter and antenna output power is less than or equal to  $60/f_{(GHz)} (P_{ref})$ . The Bluetooth module in the EUT operates in the 2.4GHz range. It has a maximum output power of 2.5mW (4dBm) which is less than  $P_{ref} (=60/2.4=25mW)$ .

Because  $(110+18.4+5=133.4) \text{ cm} > 5\text{cm}$ , and  $2.5\text{mW} < 25\text{mW}$ , the Bluetooth module was not considered for SAR evaluation. This is in accordance with the test reduction methods detailed in “**Supplement to the KDB 616217**” and KDB 447498.

**Diagram Showing distance between Peak SAR Locations**

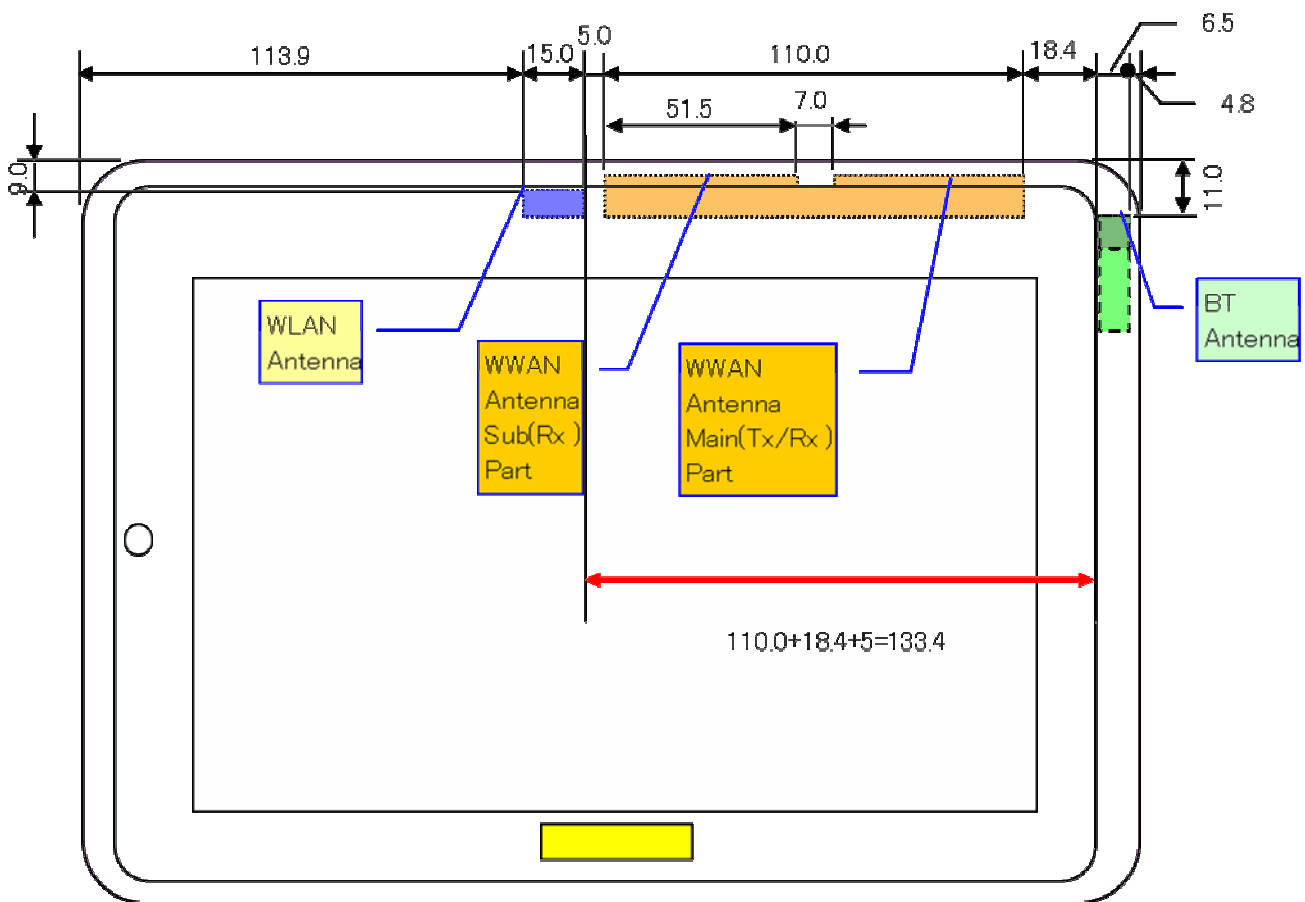

**Diagram Showing Antenna Positions**