

Attachment 3

FCC PART 15B TEST REPORT

REPORT NUMBER: FG07-172EAL

Report No. : FG07-172EAL (1/10)

EMI Test report

CATEGORY : EN55022(2006) / CISPR 22(2005) ; Class B
AS/NZS CISPR22 (2002)
FCC Part-15 (2007)
VCCI (2007)
EN301 489-01 V1.4.1

MANUFACTURER : FUJITSU LIMITED
4-1-1, Kamikodanaka, Nakahara-ku, Kawasaki 211-8588 JAPAN

PRODUCT TYPE : Personal computer P1620
Port Replicator FPCPR56
AC Adapter SED80N2-16.0 SEB55N2-16.0
WL-LAN Module WM3945ABG 4965AG_
Bluetooth module EYTF3CS FT

TEST SITE : FUJITSU GENERAL EMC LABORATORY
1116, Suenaga, Takatsu-ku, Kawasaki 213-8502 JAPAN

DATE TESTED : December 13, 2007 24°C 45%

TESTED BY : Hiroyuki Aikawa

Above EUT conforms mentioned all regulations.

APPROVED BY : for K. Shimano DATE : December 21, 2007
Hiroyuki Shimano, President

FUJITSU GENERAL EMC LABORATORY LIMITED

1116, Suenaga, Takatsu-ku, Kawasaki 213-8502 JAPAN

TEL: (044)861-7897 FAX: (044)861-9890

CLIENT : Global Business Division, FUJITSU LIMITED
4-1-1, Kamikodanaka, Nakahara-ku, Kawasaki 211-8588 JAPAN

※ The description of the EUT and the system configuration in this report are provided by the client.



Accredited by NVLAP.
Authorized by TÜV SÜD PS.
Appointed by TÜV Rheinland Japan
Registered on VCCI.

This accredited test report does not constitute an endorsement of NVLAP or the US government. Fujitsu General EMC Laboratory as a TÜV SÜD PRODUCT SERVICE (TÜV SÜD PS) recognized laboratory is entitled to print the logo on its test reports. Reports approved by a TÜV SÜD PS technical expert additionally must bear the TÜV SÜD PS stamp and authorized signature. It is not allowed to copy this report even partly without the allowance of the test laboratory in any form or by any means. ©Fujitsu General EMC Laboratory

2. EMI test results summary

Applied standard: EN55022 (2006)

Limit value: Class B

The test samples met the class B limit of EN55022(2006)/ CISPR22(2005) and applicable below regulations as shown the following highest 6 points of each emission profiles.

Australia, New Zealand: AS/NZS CISPR22(2002)

USA: FCC Part-15(2007), Canada: CAN/CSA-CEI/IEC CISPR22-02

Japan: VCCI(2007), Taiwan: CSN 13438(2006)

The telecommunication conducted emission is not covered VCCI registered.

The test result is effective in only for the EUT.

2.1 Radiated emission (30 MHz to 1,000 MHz) : Measured at 10 m distance

< AC 230 V / 50 Hz single phase, Wireless LAN module; WM3945ABG >

Freq. (MHz)	pol.	Noise level (QP; dB μ V/m)	Class B limit (QP; dB μ V/m)	Margin (dB)
47.97	Vert	23.1	30.0	6.9
56.17	Vert	22.0	30.0	8.0
64.19	Vert	25.4	30.0	4.6
120.00	Vert	23.5	30.0	6.5
624.63	Vert	31.1	37.0	5.9
745.00	Horiz	29.1	37.0	7.9

< AC 120 V / 60 Hz single phase, Wireless LAN module; 4965AG_ >

Freq. (MHz)	pol.	Noise level (QP; dB μ V/m)	Class B limit (QP; dB μ V/m)	Margin (dB)
47.97	Vert	25.0	30.0	5.0
56.17	Vert	21.8	30.0	8.2
64.19	Vert	25.2	30.0	4.8
120.00	Vert	23.2	30.0	6.8
624.64	Vert	29.9	37.0	7.1
745.00	Horiz	29.4	37.0	7.6

• Limit value ; CISPR22(2005) and applied for FCC Part-15(2007).

• Measurement uncertainty : \pm 3.3 dB (K=2, 95 %)

2.2 Over 1 GHz RF Radiated emission(1 GHz to 6.5 GHz) : Measured at 3 m distance

< AC 120 V / 60 Hz single phase, Wireless LAN module; 4965AG_ >

Freq. (GHz)	Pol	Noise level (dB μ V/m)	FCC Part-15 Class B limit		Margin (dB to AV)
			Peak	A V	
1.3829	Horiz	41.6	74.0	54.0	12.4
1.3829	Vert	46.1	74.0	54.0	7.9
1.8107	Horiz	44.1	74.0	54.0	9.9
1.8107	Vert	44.2	74.0	54.0	12.2
1.9164	Horiz	43.9	74.0	54.0	10.1
1.9164	Vert	42.4	74.0	54.0	11.6

2.3 AC power line conducted emission (150 kHz to 30 MHz)

2.3.1 AC Adapter; SED80N2-16.0

< AC 230 V / 50 Hz single phase, Wireless LAN module; WM3945ABG >

Freq. (MHz)	Line #	Noise level (dB μ V)		Class B limit (dB μ V)		Margin (dB to AV)	
		Q P	A V	Q P	A V	Q P	A V
0.190	# 1	49.8		64.0	54.0	4.2	
0.190	# 2	49.3		64.0	54.0	4.7	
0.255	# 1	48.4		61.6	51.6	3.2	
0.255	# 2	47.8		61.6	51.6	3.8	
0.320	# 1	43.4		59.7	49.7	6.3	
0.445	# 1	41.2		57.0	47.0	5.8	

< AC 120 V / 60 Hz single phase, Wireless LAN module; 4965AG_ >

Freq. (MHz)	Line #	Noise level (dB μ V)		Class B limit (dB μ V)		Margin (dB to AV)	
		Q P	A V	Q P	A V	Q P	A V
0.191	# 1	49.4		64.0	54.0	4.6	
0.191	# 2	48.0		64.0	54.0	6.0	
0.254	# 1	44.2		61.6	51.6	7.4	
0.445	# 1	40.7		57.0	47.0	6.3	
0.485	# 2	40.2		56.3	46.3	6.1	
0.504	# 2	37.3		56.0	46.0	8.7	

< AC 100 V / 50 Hz single phase, Wireless LAN module; WM3945ABG >

Freq. (MHz)	Line #	Noise level (dB μ V)		Class B limit (dB μ V)		Margin (dB to AV)	
		Q P	A V	Q P	A V	Q P	A V
0.192	# 1	48.8		64.0	54.0	5.2	
0.192	# 2	48.9		64.0	54.0	5.1	
0.443	# 1	44.0		57.0	47.0	7.0	
0.443	# 2	38.0		57.0	47.0	9.0	
0.483	# 2	38.3		56.3	46.3	8.0	
0.570	# 1	36.7		56.0	46.0	9.3	

- Limit value ; CISPR22(2005) and FCC Part-15(2007).
- Measurement uncertainty : ± 2.5 dB (K=2, 95 %)

2.3.2 AC Adapter; SEB55N2-16.0

< AC 230 V / 50 Hz single phase, Wireless LAN module; WM3945ABG >

Freq. (MHz)	Line #	Noise level (dB μ V)		Class B limit (dB μ V)		Margin (dB)	
		Q P	A V	Q P	A V	Q P	A V
0.194	# 1	55.0	41.7	63.9	53.9	8.9	12.2
0.194	# 2	55.2	43.2	63.9	53.9	8.7	10.7
0.260	# 1	48.0	34.9	61.4	51.4	13.4	16.5
0.260	# 2	48.7	38.0	61.4	51.4	12.7	13.4
0.318	# 2	47.5	36.4	59.8	49.8	12.3	13.4
0.444	# 2	43.8	30.0	57.0	47.0	13.2	17.0

< AC 120 V / 60 Hz single phase, Wireless LAN module; 4965AG_ >

Freq. (MHz)	Line #	Noise level (dB μ V)		Class B limit (dB μ V)		Margin (dB)	
		Q P	A V	Q P	A V	Q P	A V
0.193	# 1	54.4	39.9	63.9	53.9	9.5	14.0
0.193	# 2	54.2	40.1	63.9	53.9	9.7	13.8
0.320	# 1	45.5	33.8	59.7	49.7	14.2	15.9
0.320	# 2	45.4	33.6	59.7	49.7	14.3	16.1
0.420	# 2	43.1	30.0	57.5	47.5	14.4	17.5
0.510	# 2	41.7	27.7	56.0	46.0	14.3	18.3

< AC 100 V / 50 Hz single phase, Wireless LAN module; WM3945ABG >

Freq. (MHz)	Line #	Noise level (dB μ V)		Class B limit (dB μ V)		Margin (dB)	
		Q P	A V	Q P	A V	Q P	A V
0.192	# 1	51.0	34.8	64.0	54.0	13.0	19.2
0.192	# 2	51.1	38.3	64.0	54.0	12.9	15.7
0.280	# 1	44.5	29.0	60.8	50.8	16.3	21.8
0.280	# 2	45.7	31.6	60.8	50.8	15.1	19.2
0.320	# 2	43.3	29.4	59.7	49.7	16.4	20.3
0.510	# 2	40.2	25.4	56.0	46.0	15.8	20.6

• Limit value ; CISPR22(2005) and FCC Part-15(2007).

• Measurement uncertainty : ± 2.5 dB (K=2, 95 %)

2.4 Telecommunication line conducted emission

< Telecom port >

Freq. (MHz)	Noise level (dB μ V)	Class B limit (dB μ V)		Margin (dB to AV)
		Q P	A V	
1.429	47.8	74.0	64.0	16.2
1.479	49.0	74.0	64.0	15.0
1.527	49.2	74.0	64.0	14.8
1.577	48.7	74.0	64.0	15.3
1.627	47.7	74.0	64.0	16.3
16.046	56.6	74.0	64.0	7.4

< LAN port >

Freq. (MHz)	Noise level (dB μ A)	Class B limit (dB μ A)		Margin (dB to AV)
		Q P	A V	
1.428	4.9	30.0	20.0	15.1
1.477	5.7	30.0	20.0	14.3
1.527	5.7	30.0	20.0	14.3
4.096	10.9	30.0	20.0	9.1
16.046	10.1	30.0	20.0	9.9
21.479	5.8	30.0	20.0	14.2

• Limit value ; CISPR 22(2005)

3. EUT modification under the test

The following countermeasures were implemented for the radiated emission.

- ① The electro conductive cloth was add to the internal DC cable.
- ② The ferrite core was add to the internal DC cable.
- ③ The electro-conductive cloth was added to the position between the DC cable and the Modem module.

4. Measurement procedure and test equipment

The measurement was performed without deviation from CISPR22 (2005)

4.1 Radiated emission

4.1.1 Radiated emission (30MHz~1,000MHz)

The EUT was set on the 80 cm height desk placed on the turntable in the 10 m RF semi-anechoic chamber.

The PC-2, PC3 and HUB were placed at outside of the chamber to make usual install condition at the different place. The maximum noise level in the frequency range from 30 MHz to 1,000 MHz were measured by 10 m method with scanning the antenna height from 1 m to 4 m above the ground plane and rotating the EUT through 360 degrees for both horizontal and vertical polarization.

Preliminary measurement using spectrum analyzer peak detection was performed to arrange the minimum margin spectrum. The settings of the interface cables and the mouse were adjusted to obtain maximum level at the minimum margin spectrum. The final measurement was performed using the RFI receiver (CISPR Quasi-peak, 120 kHz band width) and calibrated broadband antennas or dipole antennas about the main spectrums that was obtained by the preliminary measurement.

Test equipment	Manufacturer	Type	S/N	Cal. Date	Due. Date
Bi Log antenna	Schwarzbeck	VULB9160	3118	2007.01.04	2008.01.04
Dipole antenna	Schwarzbeck	VHA9103	VHA91031573	2006.12.28	2008.12.28
Dipole antenna	Schwarzbeck	UHA9105	UHA91052119	2006.12.28	2008.12.28
Field strength meter	Rohde & Schwarz	ESCS30	849650/003	2007.04.25	2008.04.25
Spectrum analyzer	HP	85422E	3746A00242	2007.04.24	2008.04.24
RF switch	Rohde & Schwarz	PSU	848290/003	2007.05.07	2008.05.07
RF cable	-----	CF013	-----	2007.05.07	2008.05.07
2nd semi-anechoic chamber	Riken eletech	-----	-----	2007.01.16	2009.01.16
EMI test program	FGE	Version 1.3			

4.1.2 Radiated emission (1 GHz~6.5 GHz)

The EUT was set on the 80 cm height non-reflective desk on the turntable. The radiated emission measurement from 1 GHz to 6.5 GHz: Operating rate 1.3 GHz was performed using the spectrum analyzer (Peak detection, 1MHz band width) and the horn antenna that was positioned at 3 m from the EUT for class B. The measurement was performed with rotating the EUT through 360 degrees and fixing the antenna height to the 1 m for both horizontal and vertical polarization.

Test equipment	Manufacturer	Type	S/N	Cal. Date	Due. Date
Horn antenna	Schwarzbeck	BBHA9120D	414	2007.02.23	2009.02.23
Spectrum analyzer	Advantest	R3371A	75060396	2007.05.27	2008.05.27
Pre amplifier	HP	8449B	3008A01110	2007.03.24	2009.03.24
2nd semi-anechoic chamber	Riken eletech	-----	-----	2007.01.16	2009.01.16

4.2 AC power line conducted emission

The conducted emission measurement was performed using the 50Ω/50μH artificial mains network: AMN in the shielded room. The EUT was set on the 80 cm height wooden desk and operated by AC 100 V/ 50 Hz, AC 120 V/ 60 Hz and AC 230 V/ 50 Hz. Preliminary measurement using spectrum analyzer peak detection was performed in the frequency range from 150 kHz to 30 MHz to arrange the minimum margin spectrum. The setting of the cables was adjusted to obtain maximum level at the minimum margin spectrum. The final measurement was performed using the RFI receiver (CISPR Quasi-peak, 9 kHz band width) and recorded the maximum value in the monitored interval about the main spectrum that was obtained by the preliminary measurement.

Test equipment	Manufacturer	Type	S/N	Cal. Date	Due. Date
AMN for EUT	Kyoritsu	KNW-407	8-823-18	2007.01.15	2008.01.15
AMN for AE	Kyoritsu	KNW-242C	8-1387-7	2007.01.15	2008.01.15
Field strength meter	Rohde & Schwarz	ESCS30	849650/001	2007.04.25	2008.04.25
Spectrum analyzer	HP	85422E	3746A00240	2007.04.24	2008.04.24
RF switch	Rohde & Schwarz	PSU	848290/005	2007.05.07	2008.05.07
Band pass filter	Advantest	TR14202	03560025	2007.05.07	2008.05.07
10 dB Transient Limiter	Rohde & Schwarz	ESH3-Z3	0357.8810.54	2007.05.07	2008.05.07
RF cable	----	CF009	----	2007.05.07	2008.05.07
EMI test program	FGE	Version 1.3			

4.3 Telecommunication line conducted emission

The conducted emission measurement was performed using the impedance stabilization network: ISN LCL; 55 dB for telecom port, current probe for shielded LAN port in the shielded room. The EUT was set on the 40 cm height wooden desk and operated by AC 230 V/ 50 Hz. Preliminary measurement using spectrum analyzer peak detection was performed in the frequency range from 150 kHz to 30 MHz to arrange the minimum margin spectrum. The setting of the cables was adjusted to obtain maximum level at the minimum margin spectrum. The final measurement was performed using the RFI receiver (CISPR Quasi-peak, 9 kHz band width) and recorded the maximum value in the monitored interval about the main spectrum that was obtained by the preliminary measurement.

Test equipment	Manufacturer	Type	S/N	Cal. Date	Due. Date
ISN	Kyoritsu	KNW-2202	8S-2945-2	2007.09.03	2008.09.03
Current probe	Rohde & Schwarz	EZ-17	100007	2006.12.21	2007.12.21
Field strength meter	Rohde & Schwarz	ESCS30	849650/001	2007.04.25	2008.04.25
Spectrum analyzer	HP	85422E	3746A00240	2007.04.24	2008.04.24
RF switch	Rohde & Schwarz	PSU	848290/005	2007.05.07	2008.05.07
Band pass filter	Advantest	TR14202	03560025	2007.05.07	2008.05.07
10 dB plus limiter	Rohde & Schwarz	ESH3-Z3	0357.8810.54	2007.05.07	2008.05.07
RF cable	----	CF009	----	2007.05.07	2008.05.07

5. Test site and traceability

The FUJITSU GENERAL EMC LABORATORY performs the test for VCCI / EN / CISPR regulation and Fujitsu / Fujitsu General internal regulations. The test procedures and test facilities are comply with international standard. The laboratory is filed on VCCI (Japan), accredited from NVLAP (U.S.A.), authorized from TÜV SÜD PS (Germany) and appointed from TÜV Rheinland (Germany).

VCCI : 1st semi-anechoic chamber(R-753/C-776), 1st shielded room(C-777)
 Large shielded room(C-778)
 2nd semi-anechoic chamber(R-1460/C-1547), 2nd shielded room(C-1548)
 3rd shielded room(C-1549)

NVLAP : 1998.12.01 Accredited: Lab code 200373-0

TÜV SÜD PS : 1999.01.29 Authorized

TÜV Rheinland Japan : 2005.08.25 Appointed

The measuring equipments were used in the laboratory and test data are traceable to the national or international standard. Each equipment is maintain by periodical calibration and by daily check as a total measurement system to keep those accuracy.

Figure-1 System configuration and cables

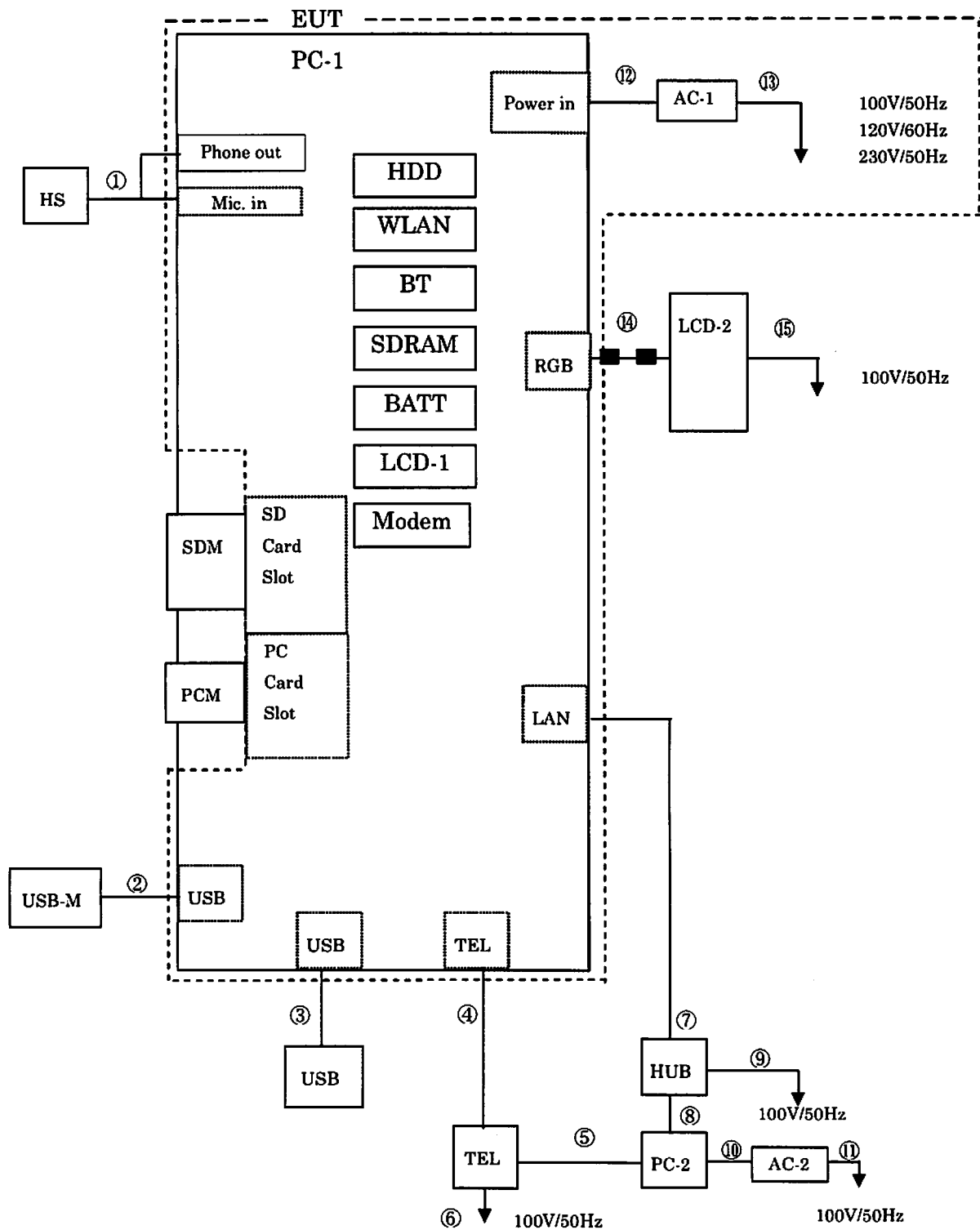

■ : Ferrite core

Main EUT

Code	Name	Type	S/N	Product
PC-1	Personal computer	P1620	Pre-production sample	Fujitsu

Related EUT

AC-1	AC adapter	SED80N2-16.0	---	Fujitsu
AC-1	AC adapter	SEB55N2-16.0	---	Fujitsu

Included device; PC-1

Code	Name	Type	S/N	Product
HDD	100GB HDD	MK1011GAH	----	TOSIBA
WLAN	Wireless LAN	4965AG_	----	Intel
WLAN	Wireless LAN	WM3945ABG	----	Intel
BT	Bluetooth	EYTF3CS FT	----	TAIYO YUDEN
DIMM	2048 MB	D2P533-2GMEJFJ6	----	Fujitsu
BATT	Battery (6 cell)	FMVNB155 10.8V 2600mA/h	----	Fujitsu
Modem	Tel Modem	MDC1.5 modem Model:D40	----	Agere
LCD-1	8.9" WXGA	HV089WX1-100	----	BOE-Hydis

Assisted equipment

Code	Name	Type	S/N	Product
LCD-2	LCD display	P19-1	YEGA217491	FSC
HS	Head set	GN 501FSC	----	FSC
PC-2	Personal computer	FMV	----	Fujitsu
HUB	Switching Hub	ETG-SH-8	VD7000010513N	----
AC-2	AC adapter	FMV-AC312	03Y15899C	Fujitsu
TEL	Telephone line emulator	TEL101- II	309688	ASCII
USB	USB Mouse	M-BT69e	HCA52701556	FSC
USB-M	USB memory	128MB	----	I·O DATA
PCM	PC memory card	20 MB	----	SunDisk
SDM	SD memory card	128 MB	----	Panasonic

Cables SLD: Shielded NSLD: Non-shielded CAX: Coaxial

Connector MC: Metal NMC: Non-metal PMC: Point contact metal

No.	I/O Port	Name	Type	Length	Cable type
①	Phone-out/Mic-in	Headset cable	----	2.2m	NSLD,NMC
②	USB	USB cable	----	1.8m	SLD,MC
③	USB	USB mouse cable	----	2.0m	SLD,MC
④	TEL	Modular cable	----	20.0m	NLD, NMC
⑤	----	Modular cable	----	1.0m	NLD, NMC
⑥	----	AC power cable	----	1.8m	2P-NSLD
⑦	LAN	LAN cable	----	20.0m	SLD, MC
⑧	----	LAN cable	----	1.0m	NSLD, NMC
⑨	----	AC power cable	----	2.0m	3P-NSLD
⑩	----	AC adaptor cable	----	1.8m	NSLD,NMC
⑪	----	AC power cable	----	1.8m	2P-NSLD
⑫	----	AC adaptor cable	----	1.6m	NSLD,NMC
⑬	----	AC power cable	----	2.0m	2P-NSLD
⑭	RGB	RGB cable	----	1.8m	SLD, MC fixed core
⑮	----	AC power cable	----	2.0m	3P-NSLD