



# **Intel® PRO/Wireless 2200BG Network Connection Mini PCI Adapter**

---

## **Functional Overview**

---

Notice: This document contains information on products in the design phase of development. The specifications are subject to change without notice. Verify with your local Intel sales office that you have the latest specifications before finalizing a design.

---





The information in this manual is furnished for informational use only, is subject to change without notice, and should not be construed as a commitment by Intel Corporation. Intel Corporation assumes no responsibility or liability for any errors or inaccuracies that may appear in this document or any software that may be provided in association with this document.

Information in this document is provided in connection with Intel products. No license, express or implied, by estoppel or otherwise, to any intellectual property rights is granted by this document. Except as provided in Intel's Terms and Conditions of Sale for such products, Intel assumes no liability whatsoever, and Intel disclaims any express or implied warranty, relating to sale and/or use of Intel products including liability or warranties relating to fitness for a particular purpose, merchantability, or infringement of any patent, copyright or other intellectual property right. Intel products are not intended for use in medical, life saving, or life sustaining applications. Intel may make changes to specifications and product descriptions at any time, without notice.

Except as permitted by such license, no part of this document may be reproduced, stored in a retrieval system, or transmitted in any form or by any means without the express written consent of Intel Corporation.

Contact your local Intel sales office or your distributor to obtain the latest specifications and before placing your product order.

Copyright © 2003 Intel Corporation

\*Third-party brands and names are the property of their respective owners.



## Table of Contents

<b>INTRODUCTION</b> .....	<b>4</b>
<b>INTEL® PRO/WIRELESS 2200BG NETWORK CONNECTION PRODUCT OVERVIEW</b> .....	<b>4</b>
<b>SYSTEM ARCHITECTURE</b> .....	<b>5</b>
<b>COMPONENT DESCRIPTIONS</b> .....	<b>5</b>
GQ82532RGE RADIO .....	5
RC82532MDE MAC AND BASEBAND.....	6
<b>HARDWARE ENVIRONMENT</b> .....	<b>6</b>
OVERVIEW.....	6
CARD DIMENSIONS .....	6
SHIELD FOR TYPE IIIA AND IIIB:.....	9
CONNECTOR INTERFACE .....	9
MINI PCI SYSTEM CONNECTOR PINS .....	10
OPERATING CHANNELS .....	11



## Introduction

The primary purpose of this document is to communicate the Intel® PRO/Wireless 2200BG Network Connection features and specifications. The Intel® PRO/Wireless 2200BG Network Connection is Intel's second generation of wireless Local Access Network (LAN) products supporting the 2.4GHz 802.11b and 2.4GHz 802.11g IEEE specifications.

This document defines the functional characteristics of the Intel® PRO/Wireless 2200BG Network Connection Mobile Unit (MU). It is intended to inform PC OEM customers of the technical characteristics and assist in the evaluation of this product. This adapter is based upon the Intel 82532 chipset for 802.11b as well as for 802.11g.

## Intel® PRO/Wireless 2200BG Network Connection Product Overview

The Intel® PRO/Wireless 2200BG Network Connection transfers data at fast wireless speeds (up to 54Mbps instantaneous data rate) over the air between two or more users or between a user and the wired network. The Intel® PRO/Wireless 2200BG Network Connection communicates to the wired LAN through 2.4GHz 802.11b or 802.11g Access Points (APs). The Intel® PRO/Wireless 2200BG Network Connection supports the Mini PCI Type IIIA/B form factor which is designed for notebook computer systems where overall thickness must be kept to an absolute minimum. The Intel® PRO/Wireless 2200BG Network Connection is 802.11b and 802.11g compliant, PCI 2.3, ACPI 2.0, WHQL compliant, and WiFi certified\*\*.

\*\*Pending WiFi certification.

## System Architecture

The single-band 2.4 GHz dual mode 802.11b and 802.11g Wireless LAN Mini PCI card is a single PCB design using Intel's 82532 2.4 GHz Wireless LAN chipset. The solution consists of two main IC's RC82532MDE and GQ82532RGE. The RC82532MDE IC provides the processor, the OFDM and CCK modulation/demodulation and digital control for the radio. GQ82532RGE provides the RF to Baseband conversion. In addition to these chips, the RF front-end consists of additional components such as antenna connectors, diversity/transmit/receive switch, bandpass filters, baluns, power amplifier (PA), and low-noise amplifier (LNA). Intel® PRO/Wireless 2200BG Network Connection supports PCI interface and consists of 32 bits of address and data as well as PCI control signals.

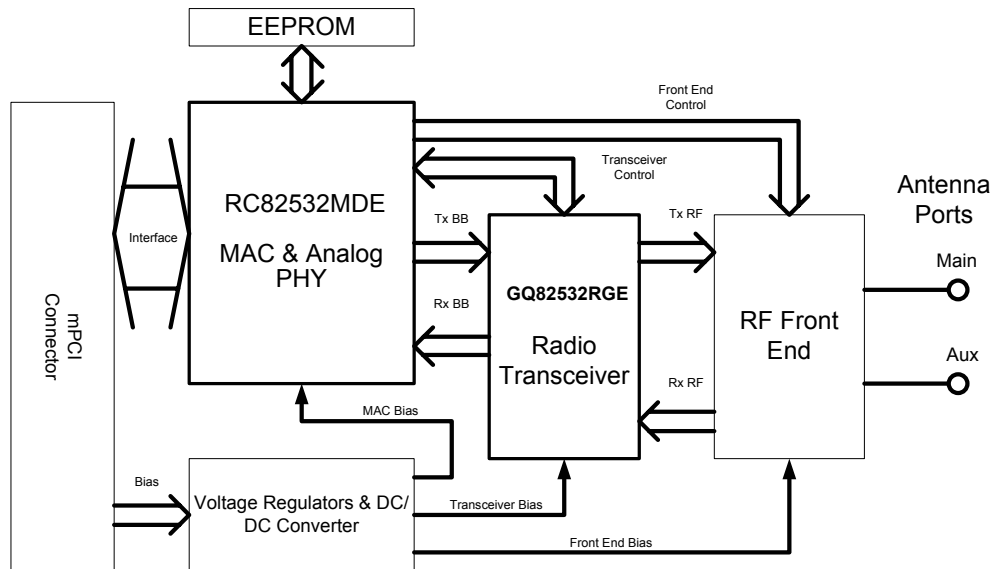

## Component Descriptions

### GQ82532RGE Radio

The GQ82532RGE is a single IC radio transceiver designed for 2.4 GHz wireless LAN applications. It acts as a slave to the physical layer (PHY) and media access control (MAC) components in RC82532MDE for both 802.11b and 802.11g modes. The transmitter combines baseband in-phase (I) and quadrature (Q) signals, up-converts them to the desired frequency channel, and drives the RF signal off-chip through the integrated power amplifier. The GQ82532RGE is a direct conversion radio architecture and combines a low-noise automatic gain control (AGC), receive and transmit filters, and input/output buffers into a single IC.



## RC82532MDE MAC and Baseband

The RC82532MDE chip incorporates media access control (MAC) logic, baseband processing functions, and a PCI/Mini PCI/CardBus host interface, as well as analog-to-digital and digital-to-analog converters (ADC and DAC). This fully integrated digital processor eliminates the need for external RAM and flash memory.

The RC82532MDE implements a half duplex CCK and OFDM baseband processor. The RC82532MDE is supporting all IEEE 802.11b and 802.11g mandatory and optional data rates from 1 Mbps to 54 Mbps using several modulation schemes: binary phase shift keying (BPSK), quadrature phase shift keying (QPSK), complementary code keying (CCK), 16 quadrature amplitude modulation (16 QAM), and 64 QAM.

The RC82532MDE is compliant with 802.11b and 802.11g protocols. The upper level MAC controls the non-real time protocols such as roaming and scanning the transmit/receiver (Tx, Rx) queues. The lower level MAC controls the real time channel access, the DSP, and the radio.

Frequency stability: The 40MHz clock has a maximum of 20ppm. It is multiplied up to generate the transmit signal. Hence at 2.412GHz we will have an error of  $2.412\text{GHz} \times 20\text{ppm}$  when tuned to the lower channel and at the extreme it will be  $2.484\text{GHz} \times 20\text{ppm}$  when tuned to the upper channel.

## Hardware Environment

### Overview

The Intel® PRO/Wireless 2200BG Network Connection can be used in both notebook and tablet PCs with Mini PCI and antenna support to provide wireless network access. The Mini PCI card communicates over the air between two or more users or between a user and the wired network via an Access Point. The Intel® PRO/Wireless 2200BG Network Connection implements the IEEE 802.11b and 802.11g physical (RF) specifications. It operates at 1,2,5.5,6,9,11,12,18,24,36,48 and 54 Mbps @2.4GHz. The Mini PCI card uses the RC82532MDE for modulation, demodulation, spreading, disspreading and processing, and the GQ82532RGE as a direct conversion radio of the RF-Base Band signals.

### Card Dimensions

The Intel® PRO/Wireless 2200BG Network Connection complies with the dimensions of a Mini PCI type IIIA card and Mini PCI type IIIB card with the exception of the mated antenna connector height (deviates from specification by 0.1mm in the Z-dimension). For Type IIIA, the length is  $50.65 \pm 0.15$  mm and the width is  $59.30 \pm 0.15$  mm. For Type IIIB, the length is  $44.30 \pm 0.15$  mm and the width is  $59.30 \pm 0.15$  mm.

Type IIIA:

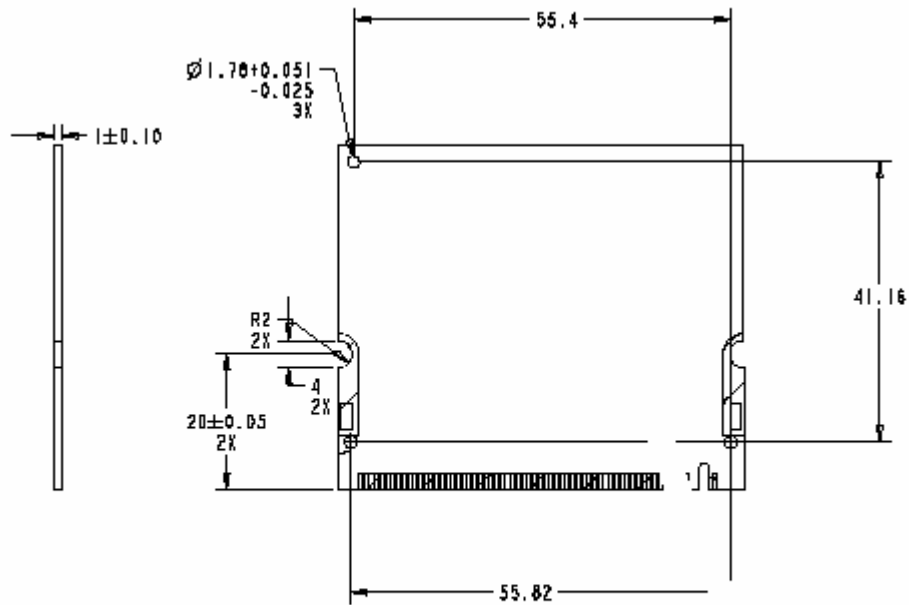
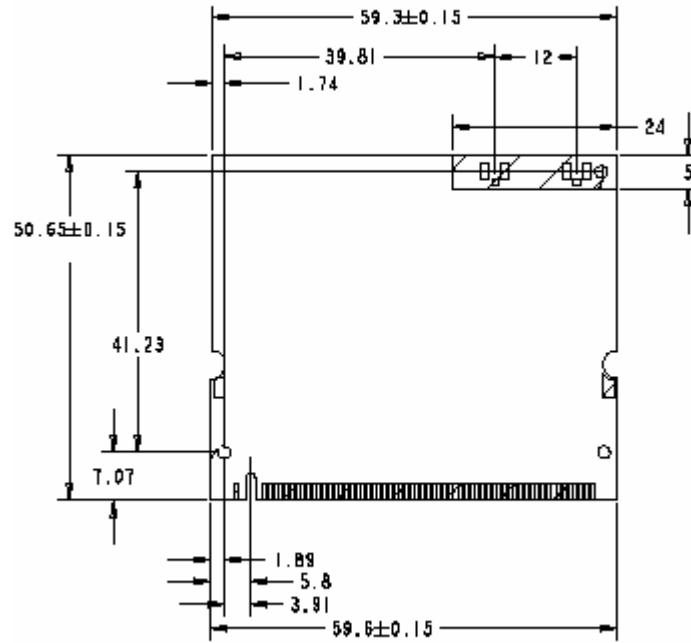

TOP SIDE PCB OUTLINE

Type IIIB:

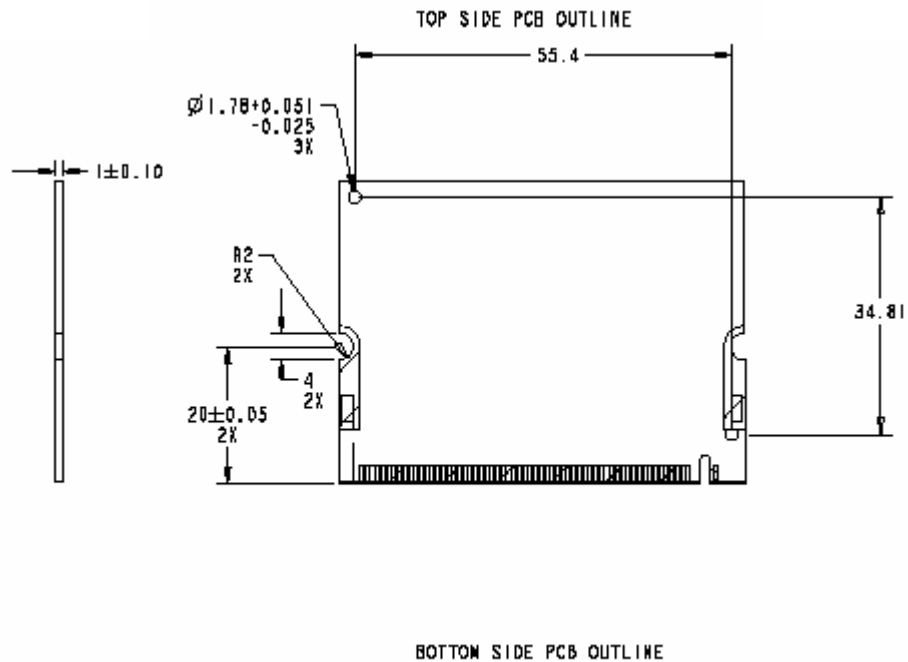
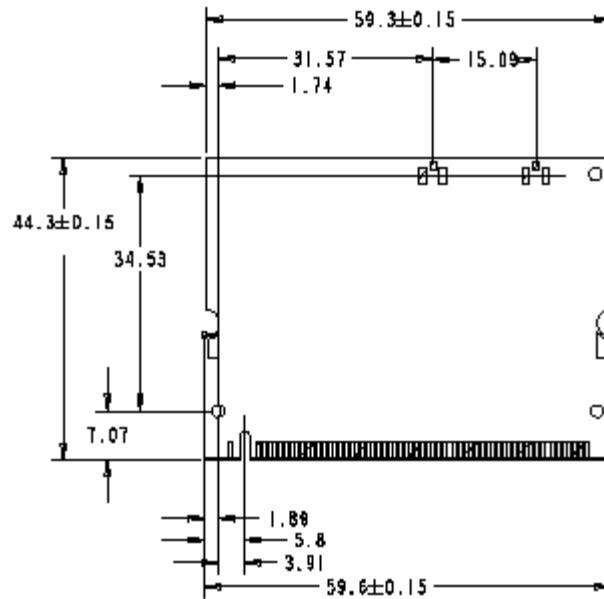

The Hirose U.FL-R-SMT connector will be used on Intel® PRO/Wireless 2200BG Network Connection to mate with cable connector U.FL-LP-066.



**Shield for Type IIIA and IIIB:**

The shield shown below will be placed on the component side (top) in both form factors.

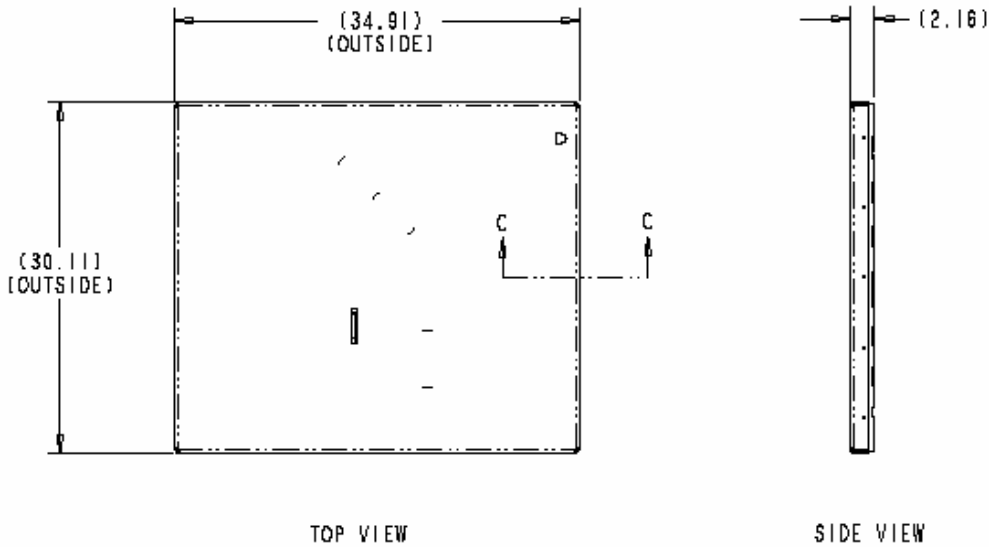

**Connector Interface**

Below is the mechanical information for the Mini PCI edge connector as it is specified within the Mini PCI rev. 1.0 specification. The following sections detail Intel's modifications from this specification to improve the contact reliability for our customers.

Revision 1.0



Figure 5-15 shows contact finger detail for the Type III PCB.

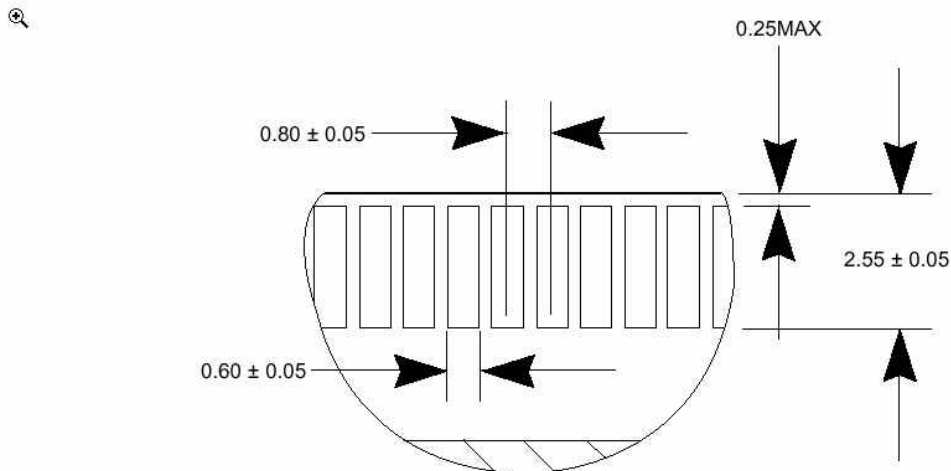

**Figure 5-15: Type III PCB, Bottom Side, Detail E**

Intel® PRO/Wireless 2200BG Network Connection will implement the following bevel finish design to avoid possible connector damage.

## Mini PCI System Connector Pins

The Mini PCI edge connector pin-out definition as described in the Mini PCI Specification, Revision 1.0, as shown below. The Intel® PRO/Wireless 2200BG Network Connection complies with this pin-out except for deviations as noted in this section.

**Table 1: Mini PCI Card Type III System Connector Pin-out**

Pin	Signal	Pin	Signal	Pin	Signal	Pin	Signal
1	TIP	2	RING	63	3.3V	64	FRAME#
KEY		KEY		65	CLKRUN#	66	TRDY#
3	8PMJ-3	4	8PMJ-1	67	SERR#	68	STOP#
5	8PMJ-6	6	8PMJ-2	69	GROUND	70	3.3V
7	8PMJ-7	8	8PMJ-4	71	PERR#	72	DEVSEL#
9	8PMJ-8	10	8PMJ-5	73	C/BE[1]#	74	GROUND
11	LED1_GRNP	12	LED2_YELP	75	AD[14]	76	AD[15]
13	LED1_GRNN (Radio Kill Option)	14	LED2_YELN	77	GROUND	78	AD[13]
15	CHSGND	16	RESERVED	79	AD[12]	80	AD[11]
17	INTB#	18	5V	81	AD[10]	82	GROUND
19	3.3V	20	INTA#	83	GROUND	84	AD[09]
21	RESERVED	22	RESERVED	85	AD[08]	86	C/BE[0]#
23	GROUND	24	3.3VAUX	87	AD[07]	88	3.3V
25	CLK	26	RST#	89	3.3V	90	AD[06]
27	GROUND	28	3.3V	91	AD[05]	92	AD[04]
29	REQ#	30	GNT#	93	RESERVED	94	AD[02]
31	3.3V	32	GROUND	95	AD[03]	96	AD[00]
33	AD[31]	34	PME#	97	5V	98	RESERVED_WIP98 (Radio Kill Option)
35	AD[29]	36	RESERVED (Bluetooth Coexistence Option)	99	AD[01]	100	RESERVED_WIP100
37	GROUND	38	AD[30]	101	GROUND	102	GROUND
39	AD[27]	40	3.3V	103	AC_SYNC	104	M66EN
41	AD[25]	42	AD[28]	105	AC_SDATA_IN	106	AC_SDATA_OUT
43	RESERVED (Bluetooth Coexistence Option)	44	AD[26]	107	AC_BIT_CLK	108	AC_CODEC_ID0#
45	C/BE[3]#	46	AD[24]	109	AC_CODEC_ID1#	110	AC_RESET#
47	AD[23]	48	IDSEL	111	MOD_AUDIO_MON	112	RESERVED
49	GROUND	50	GROUND	113	AUDIO_GND	114	GROUND
51	AD[21]	52	AD[22]	115	SYS_AUDIO_OUT	116	SYS_AUDIO_IN
53	AD[19]	54	AD[20]	117	SYS_AUDIO_OUT GND	118	SYS_AUDIO_IN GND
55	GROUND	56	PAR	119	AUDIO_GND	120	AUDIO_GND
57	AD[17]	58	AD[18]	121	RESERVED	122	MPCIACT#
59	C/BE[2]#	60	AD[16]	123	VCC5VA	124	3.3VAUX
61	IRDY#	62	GROUND				



## Operating Channels

802.11b/g:

Channel-ID	Frequency (MHz)	US & Canada	ETSI	Spain	France	Japan
1	2412	X	X	X	X	X
2	2417	X	X	X	X	X
3	2422	X	X	X	X	X
4	2427	X	X	X	X	X
5	2432	X	X	X	X	X
6	2437	X	X	X	X	X
7	2442	X	X	X	X	X
8	2447	X	X	X	X	X
9	2452	X	X	X	X	X
10	2457	X	X	X	X	X
11	2462	X	X	X	X	X
12	2467		X	X	X	X
13	2472		X	X	X	X
14	2484					X