

Test report

313401-1TRFWL

Date of issue: November 18, 2016

Applicant:

Mitel Networks Corporation

Product:

IP Phone

Model:

6940

FCC ID:

EHTAQUA4

IC Registration number:

173A-AQUA4

Specifications:

◆ **FCC 47 CFR Part 15 Subpart C, §15.247**

Operation in the 902–928 MHz, 2400–2483.5 MHz, 5725–5850 MHz

◆ **RSS-247, Issue 1, May 2015, Section 5**

Digital Transmission Systems (DTSS), Frequency Hopping Systems (FHSs)
and Licence-Exempt Local Area Network (LE-LAN) Devices

Test location

Company name	Nemko Canada Inc.
Address	303 River Road
City	Ottawa
Province	Ontario
Postal code	K1V 1H2
Country	Canada
Telephone	+1 613 737 9680
Facsimile	+1 613 737 9691
Toll free	+1 800 563 6336
Website	www.nemko.com
Site number	FCC: 176392; IC: 2040A-4 (3 m semi anechoic chamber)

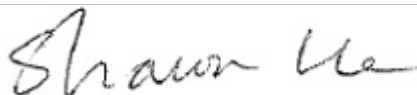
Tested by	David Duchesne, Senior EMC/Wireless Specialist and Andrey Adelberg, Senior Wireless/EMC Specialist
Reviewed by	Shawn He, Senior EMC Specialist
Review date	November 18, 2016
Reviewer signature	

Limits of responsibility

Note that the results contained in this report relate only to the items tested and were obtained in the period between the date of initial receipt of samples and the date of issue of the report.

This test report has been completed in accordance with the requirements of ISO/IEC 17025. All results contain in this report are within Nemko Canada's ISO/IEC 17025 accreditation.

Copyright notification

Nemko Canada Inc. authorizes the applicant to reproduce this report provided it is reproduced in its entirety and for use by the company's employees only. Any use which a third party makes of this report, or any reliance on or decisions to be made based on it, are the responsibility of such third parties. Nemko Canada Inc. accepts no responsibility for damages, if any, suffered by any third party as a result of decisions made or actions based on this report. © Nemko Canada Inc.

Table of contents

Table of contents	3
Section 1. Report summary	4
1.1 Applicant and manufacturer	4
1.2 Test specifications	4
1.3 Test methods.....	4
1.4 Statement of compliance	4
1.5 Exclusions.....	4
1.6 Test report revision history	4
Section 2. Summary of test results	5
2.1 FCC Part 15 Subpart C, general requirements test results.....	5
2.2 FCC Part 15 Subpart C, intentional radiators test results.....	5
2.3 IC RSS-GEN, Issue 4, test results	5
2.4 IC RSS-247, Issue 1, test results	6
Section 3. Equipment under test (EUT) details	7
3.1 Sample information.....	7
3.2 EUT information	7
3.3 Technical information	7
3.4 Product description and theory of operation	7
3.5 EUT exercise details.....	7
3.6 EUT setup diagram	8
3.7 EUT sub assemblies	8
Section 4. Engineering considerations	9
4.1 Modifications incorporated in the EUT.....	9
4.2 Technical judgment	9
4.3 Deviations from laboratory tests procedures	9
Section 5. Test conditions	10
5.1 Atmospheric conditions	10
5.2 Power supply range.....	10
Section 6. Measurement uncertainty	11
6.1 Uncertainty of measurement	11
Section 7. Test equipment	12
7.1 Test equipment list.....	12
Section 8. Testing data	13
8.1 FCC 15.207(a) and RSS-Gen 8.8 AC power line conducted emissions limits	13
8.2 FCC 15.247(a)(2) and RSS-247 5.2(1): 6 dB bandwidth (DTS-BLE).....	18
8.3 FCC 15.247(a)(1) and RSS-247 5.1(1) Frequency Hopping Systems requirements.....	20
8.4 FCC 15.247(b) and RSS-247 5.4 (4) Transmitter output power and e.i.r.p. requirements (DTS-BLE)	24
8.5 FCC 15.247(b) and RSS-247 5.4 (2) Transmitter output power and e.i.r.p. requirements (FHSS-BT).....	26
8.6 FCC 15.247(d) and RSS-247 5.5 Spurious (out-of-band) emissions	30
8.7 FCC 15.247(e) and RSS-247 5.2(2) Power spectral density for digitally modulated devices (DTS-BLE)	57
Section 9. Block diagrams of test set-ups	59
9.1 Radiated emissions set-up for frequencies below 1 GHz.....	59
9.2 Radiated emissions set-up for frequencies above 1 GHz.....	59
9.3 Conducted emissions set-up	60

Section 1. Report summary

1.1 Applicant and manufacturer

Company name	Mitel Networks Corporation
Address	350 Legget Drive, Kanata, ON, Canada, K2K 2W7

1.2 Test specifications

FCC 47 CFR Part 15, Subpart C, Clause 15.247	Operation in the 902–928 MHz, 2400–2483.5 MHz, and 5725–5850 MHz.
RSS-247, Issue 1, May 2015, Section 5	Digital Transmission Systems (DTSs), Frequency Hopping Systems (FHSs) and Licence-Exempt Local Area Network (LE-LAN) Devices

1.3 Test methods

558074 D01 DTS Meas Guidance v03 r05 (April 8, 2016)	Guidance for Performing Compliance Measurements on Digital Transmission Systems (DTS) Operating Under §15.247
ANSI C63.10 v2013	American National Standard of Procedures for Compliance Testing of Unlicensed Wireless Devices
DA 00-705 Released March 30, 2000	Filing and Measurement Guidelines for Frequency Hopping Spread Spectrum Systems

1.4 Statement of compliance

In the configuration tested, the EUT was found compliant.

Testing was completed against all relevant requirements of the test standard. Results obtained indicate that the product under test complies in full with the requirements tested. The test results relate only to the items tested.

See “Summary of test results” for full details.

1.5 Exclusions

None

1.6 Test report revision history

Table 1.6-1: Test report revision history

Revision #	Details of changes made to test report
TRF	Original report issued

Notes: None

Section 2. Summary of test results

2.1 FCC Part 15 Subpart C, general requirements test results

Table 2.1-1: FCC part 15 Subpart C test results

Part	Test description	Verdict
§15.207(a)	Conducted limits	Pass
§15.31(e)	Variation of power source	Pass ¹
§15.203	Antenna requirement	Pass ²

Notes: ¹ Measurements of the variation of the input power or the radiated signal level of the fundamental frequency component of the emission, as appropriate, was performed with the supply voltage varied between 85 % and 115 % of the nominal rated supply voltage. No noticeable output power variation was observed
² The antenna is located within the enclosure of EUT and not user accessible.

2.2 FCC Part 15 Subpart C, intentional radiators test results

Table 2.2-1: FCC part 15 Subpart C, §15.247 test results

Part	Test description	Verdict
§15.247(a)(1)(i)	Frequency hopping systems operating in the 902–928 MHz band	Not applicable
§15.247(a)(1)(ii)	Frequency hopping systems operating in the 5725–5850 MHz band	Not applicable
§15.247(a)(1)(iii)	Frequency hopping systems operating in the 2400–2483.5 MHz band	Pass
§15.247(a)(2)	Minimum 6 dB bandwidth for systems using digital modulation techniques	Pass
§15.247(b)(1)	Maximum peak output power of frequency hopping systems operating in the 2400–2483.5 MHz band and 5725–5850 MHz band	Pass
§15.247(b)(2)	Maximum peak output power of Frequency hopping systems operating in the 902–928 MHz band	Not applicable
§15.247(b)(3)	Maximum peak output power of systems using digital modulation in the 902–928 MHz, 2400–2483.5 MHz, and 5725–5850 MHz bands	Pass
§15.247(c)(1)	Fixed point-to-point operation with directional antenna gains greater than 6 dBi	Not applicable
§15.247(c)(2)	Transmitters operating in the 2400–2483.5 MHz band that emit multiple directional beams	Not applicable
§15.247(d)	Spurious emissions	Pass
§15.247(e)	Power spectral density for digitally modulated devices	Pass
§15.247(f)	Time of occupancy for hybrid systems	Not applicable

Notes: EUT operates in two modes: frequency hopping device (BT) and digitally modulated device (BLE)

2.3 IC RSS-GEN, Issue 4, test results

Table 2.3-1: RSS GEN test results

Part	Test description	Verdict
7.1.2	Receiver radiated emission limits	Not applicable ¹
7.1.3	Receiver conducted emission limits	Not applicable ¹
8.8	Power Line Conducted Emissions Limits for Licence-Exempt Radio Apparatus	Pass

Notes: ¹ According to sections 5.2 and 5.3 of RSS-Gen, Issue 4 the EUT does not have a stand-alone receiver neither scanner receiver, therefore exempt from receiver requirements.

2.4 IC RSS-247, Issue 1, test results

Table 2.4-1: RSS 247 test results

Part	Test description	Verdict
5.1	Frequency Hopping Systems (FHSs)	
5.1 (1)	Bandwidth of a frequency hopping channel	Pass
5.1 (2)	Minimum channel spacing for frequency hopping systems	Pass
5.1 (3)	Frequency hopping systems operating in the 902–928 MHz band	Not applicable
5.1 (4)	Frequency hopping systems operating in the 2400–2483.5 MHz band	Pass
5.1 (5)	Frequency hopping systems operating in the 5725–5850 MHz band	Not applicable
5.2	Digital Transmission Systems (DTSSs)	
5.2 (1)	Minimum 6 dB bandwidth	Pass
5.2 (2)	Maximum power spectral density	Pass
5.3	Hybrid Systems	
5.3 (1)	Digital modulation turned off	Not applicable
5.3 (2)	Frequency hopping turned off	Not applicable
5.4	Transmitter output power and e.i.r.p. requirements	
5.4 (1)	Frequency hopping systems operating in the 902–928 MHz band	Not applicable
5.4 (2)	Frequency hopping systems operating in the 2400–2483.5 MHz band	Pass
5.4 (3)	Frequency hopping systems operating in the 5725–5850 MHz	Not applicable
5.4 (4)	Systems employing digital modulation techniques	Pass
5.4 (5)	Point-to-point systems in 2400–2483.5 MHz and 5725–5850 MHz band	Not applicable
5.4 (6)	Transmitters which operate in the 2400–2483.5 MHz band with multiple directional beams	Not applicable
5.5	Out-of-band emissions	Pass

Notes: EUT operates in two modes: frequency hopping device (BT) and digitally modulated device (BLE)

Section 3. Equipment under test (EUT) details

3.1 Sample information

Receipt date	July 18, 2016
Nemko sample ID number	133-002561 (conducted sample), 133-002582 (radiated sample)

3.2 EUT information

Product name	IP phone
Model	6940
Part number	5601014404RA
Serial number	2WJFW162600P (conducted sample); AH-AAE-4369 (radiated sample)

3.3 Technical information

Applicant IC company number	173A
IC UPN number	AQUA4
All used IC test site(s) Reg. number	2040A-4
RSS number and Issue number	RSS-247 Issue 1, May 2015
Frequency band	2400–2483.5 MHz
Frequency Min (MHz)	2402
Frequency Max (MHz)	2480
RF power BT (W), Conducted	0.0058 (7.64 dBm)
RF power BLE (W), Conducted	0.0052 (7.20 dBm)
Field strength, Units @ distance	N/A
Measured BW (kHz) (20 dB for BT)	897
Measured BW (kHz) (6 dB for BLE)	711
Calculated BW (kHz), as per TRC-43	N/A
Type of modulation	(BLE) GFSK; (BT) ACL Basic and EDR, SCO Basic, and eSCO Basic and EDR
Emission classification (F1D, G1D, D1D)	F1E
Transmitter spurious, Units @ distance	53.83 dB μ V/m average at 2483.5 MHz @ 3 m
Power requirements	48 V _{DC} PoE (Powered via PoE adapter 120 V _{AC} 60 Hz)
Antenna information	SMD Antenna, EIA 1210, Detuning resilient, Edge Mount P/N 2450AT18D0100 1.5 dBi gain. The EUT uses a unique antenna coupling/ non-detachable antenna to the intentional radiator.

3.4 Product description and theory of operation

EUT is an IP phone with Bluetooth and BLE connectivity.

3.5 EUT exercise details

EUT was connected to a laptop running BlueTech software via USB programming kit that was used to control RF parameters.

3.6 EUT setup diagram

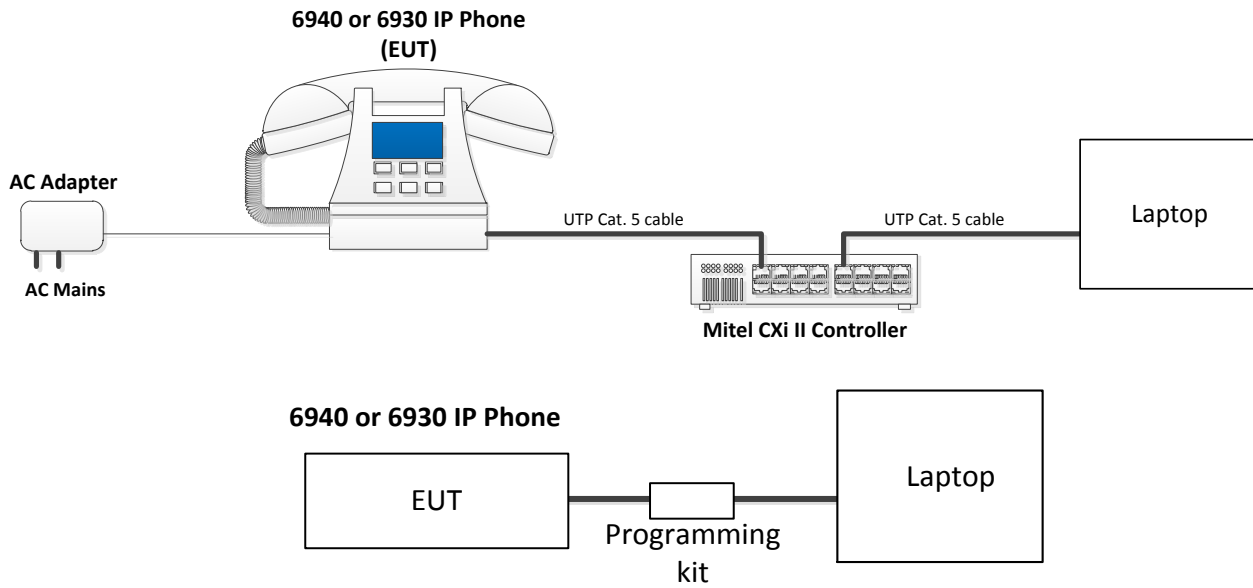

Figure 3.6-1: Setup diagram for Radiated and conducted measurements

3.7 EUT sub assemblies

Table 3.7-1: EUT sub assemblies

Description	Brand name	Model/Part number	Serial number
Mitel Switch with POE	Mitel	3300 CXi II Controller	None
AC Adapter	Adapter Tech	ATS036T-W480V	None
Laptop	Dell	Latitude D600	G8RZ461 (166-002584)

Section 4. Engineering considerations

4.1 Modifications incorporated in the EUT

There were no modifications performed to the EUT during this assessment.

4.2 Technical judgment

None

4.3 Deviations from laboratory tests procedures

No deviations were made from laboratory procedures.

Section 5. Test conditions

5.1 Atmospheric conditions

Temperature	15–30 °C
Relative humidity	20–75 %
Air pressure	860–1060 mbar

When it is impracticable to carry out tests under these conditions, a note to this effect stating the ambient temperature and relative humidity during the tests shall be recorded and stated.

5.2 Power supply range

The normal test voltage for equipment to be connected to the mains shall be the nominal mains voltage. For the purpose of the present document, the nominal voltage shall be the declared voltage, or any of the declared voltages $\pm 5\%$, for which the equipment was designed.

Section 6. Measurement uncertainty

6.1 Uncertainty of measurement

Measurement uncertainty budgets for the tests are detailed below. Measurement uncertainty calculations assume a coverage factor of $K = 2$ with 95% certainty.

Test name	Measurement uncertainty, dB
All antenna port measurements	0.55
Conducted spurious emissions	1.13
Radiated spurious emissions	3.78
AC power line conducted emissions	3.55

Section 7. Test equipment

7.1 Test equipment list

Table 7.1-1: Equipment list

Equipment	Manufacturer	Model no.	Asset no.	Cal cycle	Next cal.
3 m EMI test chamber	TDK	SAC-3	FA002047	1 year	Dec. 01/16
Receiver/spectrum analyzer	Rohde & Schwarz	ESU 26	FA002043	1 year	Jan. 07/17
Spectrum analyzer	Rohde & Schwarz	FSU	FA001877	1 year	Apr. 15/17
Bilog antenna (20–3000 MHz)	Sunol	JB3	FA002108	1 year	Apr. 28/17
Horn antenna (1–18 GHz)	EMCO	3115	FA000825	1 year	Apr. 26/17
Horn antenna 18–40 GHz	EMCO	3116	FA001847	1 year	Apr.15/17
Pre-amplifier (1–18 GHz)	JCA	JCA118-503	FA002091	1 year	April 26/17
Pre-amplifier (18–26 GHz)	Narda	BBS-1826N612	FA001550	—	VOU
Notch filter 2400–2483 MHz	Microwave Circuits	2400–2483 MHz	FA001940	—	VOU

Notes: VOU - verify on use

Table 7.1-2: test software

Test description	Manufacturer of Software	Details
Radiated emissions – Ottawa	Rhode & Schwarz	EMC32, Software for EMC Measurements, Version 9.26.01

Notes: None

Section 8. Testing data

8.1 FCC 15.207(a) and RSS-Gen 8.8 AC power line conducted emissions limits

8.1.1 Definitions and limits

FCC §15.207 (a):

Except as shown in paragraphs (b) and (c) of this section, for an intentional radiator that is designed to be connected to the public utility (AC) power line, the radio frequency voltage that is conducted back onto the AC power line on any frequency or frequencies, within the band 150 kHz to 30 MHz, shall not exceed the limits in the following table, as measured using a 50 μH/50 Ω line impedance stabilization network (LISN). Compliance with the provisions of this paragraph shall be based on the measurement of the radio frequency voltage between each power line and ground at the power terminal. The lower limit applies at the boundary between the frequency ranges.

RSS-GEN, Clause 8.8:

A radio apparatus that is designed to be connected to the public utility (AC) power line shall ensure that the radio frequency voltage, which is conducted back onto the AC power line on any frequency or frequencies within the band 150 kHz to 30 MHz, shall not exceed the limits in table below.

Unless the requirements applicable to a given device state otherwise, for any radio apparatus equipped to operate from the public utility AC power supply either directly or indirectly (such as with a battery charger), the radio frequency voltage of emissions conducted back onto the AC power lines in the frequency range of 0.15 MHz to 30 MHz shall not exceed the limits shown in table below. The more stringent limit applies at the frequency range boundaries.

Table 8.1-1: AC power line conducted emissions limits

Frequency of emission, MHz	Conducted limit, dBμV	
	Quasi-peak	Average**
0.15–0.5	66 to 56*	56 to 46*
0.5–5	56	46
5–30	60	50

Notes: * - The level decreases linearly with the logarithm of the frequency.
 ** - A linear average detector is required.

8.1.2 Test summary

Verdict	Pass				
Test date	July 20, 2016	Test engineer	David Duchesne		
Temperature	23.9 °C	Relative humidity	64 %	Air pressure	998 mbar

8.1.3 Notes

None

8.1.4 Setup details

Port under test	AC input of External POE
EUT setup configuration	Table top
Measurement details	A preview measurement was generated with the receiver in continuous scan mode. Emissions detected within 6 dB or above limit were re-measured with the appropriate detector against the correlating limit and recorded as the final measurement.

Receiver settings:

Resolution bandwidth	9 kHz
Video bandwidth	30 kHz
Detector mode	<ul style="list-style-type: none">– Peak and Average (Preview measurement)– Quasi-peak and CAverage (Final measurement)
Trace mode	Max Hold
Measurement time	<ul style="list-style-type: none">– 100 ms (Peak and Average preview measurement)– 1000 ms (Quasi-peak final measurement)– 160 ms (CAverage final measurement)

8.1.5 Test data

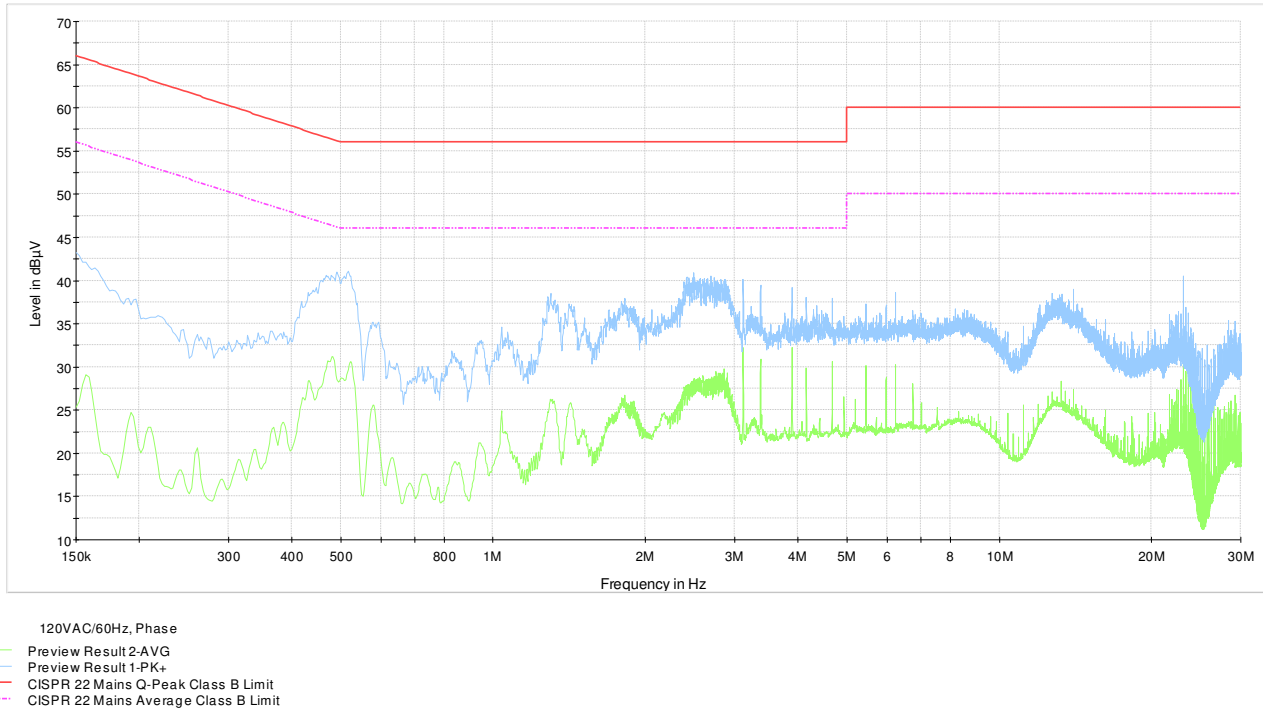

The spectral plot has been corrected with transducer factors. (i.e. cable loss, LISN factors, and attenuators)

Figure 8.1-1: AC power line conducted emissions limits – phase line

8.1.5 Test data, continued

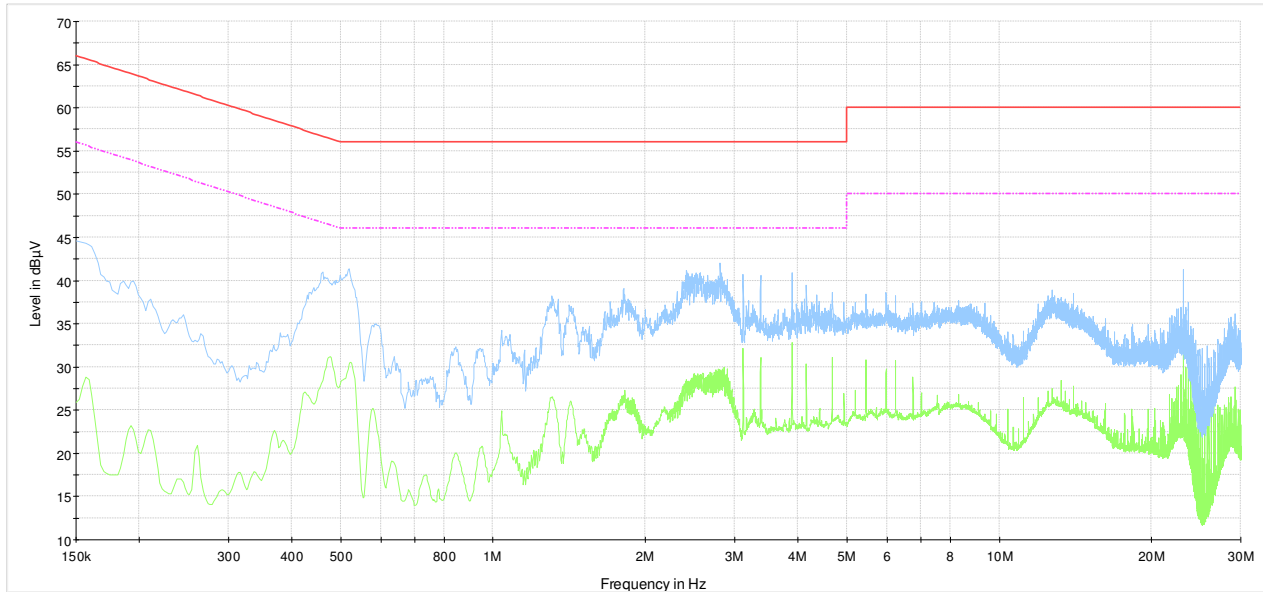

- 120VAC/60Hz, Neutral
- Preview Result 2-AVG
- Preview Result 1-PK+
- CISPR 22 Mains Q-Peak Class B Limit
- CISPR 22 Mains Average Class B Limit

The spectral plot has been corrected with transducer factors. (i.e. cable loss, LISN factors, and attenuators)

Figure 8.1-2: AC power line conducted emissions limits – neutral line

8.1.6 Setup photos

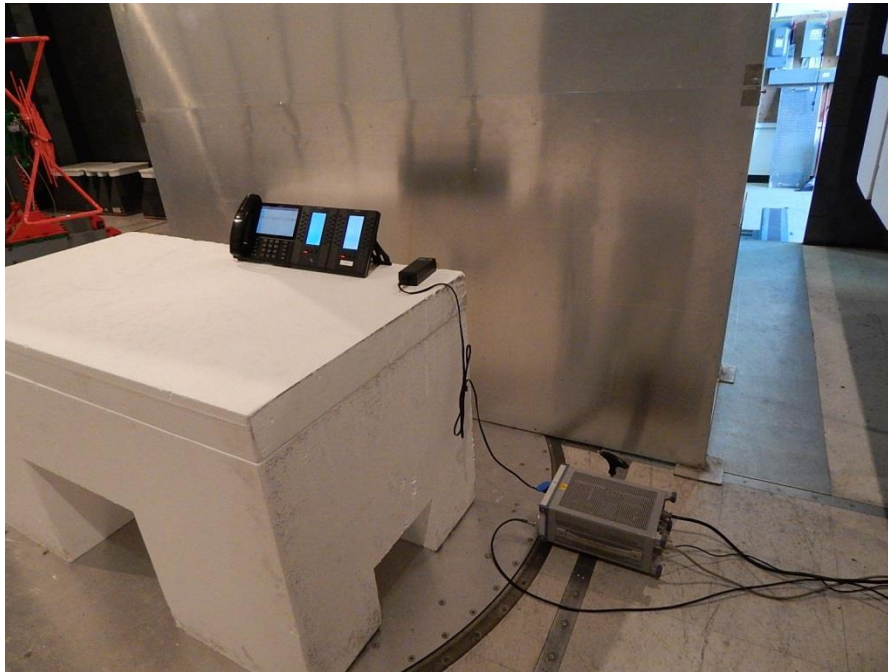

Figure 8.1-3: AC power line conducted emissions limits setup photo



Figure 8.1-4: AC power line conducted emissions limits setup photo

8.2 FCC 15.247(a)(2) and RSS-247 5.2(1): 6 dB bandwidth (DTS-BLE)

8.2.1 Definitions and limits

FCC §15.247 (a)(2):

- (a) Operation under the provisions of this Section is limited to frequency hopping and digitally modulated intentional radiators that comply with the following provisions:
 - (2) Systems using digital modulation techniques may operate in the 902–928 MHz, 2400–2483.5 MHz and 5725–5850 MHz bands. The minimum 6 dB bandwidth shall be at least 500 kHz.

RSS-247, Clause 5.2 (1):

The minimum 6 dB bandwidth shall be 500 kHz.

8.2.2 Test summary

Verdict	Pass				
Test date	July 22, 2016	Test engineer	Andrey Adelberg		
Temperature	22 °C	Relative humidity	49 %	Air pressure	1006 mbar

8.2.3 Notes

- The EUT was set to transmit in **BLE mode**.
- Measurements were performed as per 558074 D01 DTS Meas Guidance v03r05 (The test was performed using method described in Section 8.1)

8.2.4 Setup details

Spectrum analyser settings: for 6 dB bandwidth test:

Resolution bandwidth	100 kHz
Video bandwidth	≥3 × RBW
Frequency span	2 MHz
Detector mode	Peak
Trace mode	Max Hold

8.2.5 Test data

Table 8.2-1: 6 dB bandwidth results

Frequency, MHz	6 dB bandwidth, kHz	Minimum limit, kHz	Margin, kHz
2402	702	500	202
2440	702	500	202
2480	711	500	211

Notes: None

8.2.6 Test data, continued

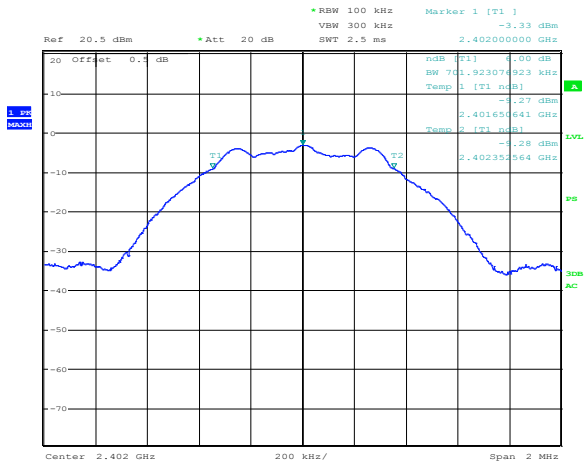

Figure 8.2-1: 6 dB bandwidth on low channel

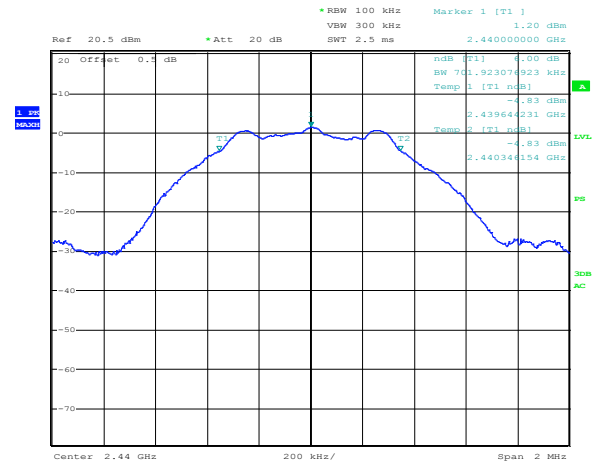
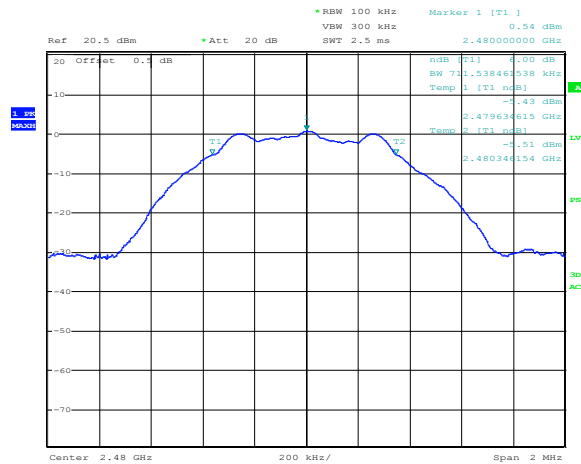

Figure 8.2-2: 6 dB bandwidth on mid channel



Date: 22.JUL.2016 16:52:09

Figure 8.2-3: 6 dB bandwidth on high channel

8.3 FCC 15.247(a)(1) and RSS-247 5.1(1) Frequency Hopping Systems requirements

8.3.1 Definitions and limits

FCC §15.247 (a)(1) (iii):

- (1) Frequency hopping systems shall have hopping channel carrier frequencies separated by a minimum of 25 kHz or the 20 dB bandwidth of the hopping channel, whichever is greater. The system shall hop to channel frequencies that are selected at the system hopping rate from a pseudo randomly ordered list of hopping frequencies. Each frequency must be used equally on the average by each transmitter. The system receivers shall have input bandwidths that match the hopping channel bandwidths of their corresponding transmitters and shall shift frequencies in synchronization with the transmitted signals.

- (iii) Frequency hopping systems in the 2400–2483.5 MHz band shall use at least 15 channels. The average time of occupancy on any channel shall not be greater than 0.4 seconds within a period of 0.4 seconds multiplied by the number of hopping channels employed. Frequency hopping systems may avoid or suppress transmissions on a particular hopping frequency provided that a minimum of 15 channels are used.

RSS-247, Clause 5.1:

- 1. The bandwidth of a frequency hopping channel is the –20 dB emission bandwidth, measured with the hopping stopped. The system’s radio frequency (RF) bandwidth is equal to the channel bandwidth multiplied by the number of channels in the hopset. The hopset shall be such that the near-term distribution of frequencies appears random, with sequential hops randomly distributed in both direction and magnitude of change in the hopset, whereas the long-term distribution appears evenly distributed.
- 2. FHSs shall have hopping channel carrier frequencies separated by a minimum of 25 kHz or the –20 dB bandwidth of the hopping channel, whichever is greater. The system receivers shall have input bandwidths that match the hopping channel bandwidths of their corresponding transmitters and shall shift frequencies in synchronization with the transmitted signals.
- 4. FHSS operating in the band 2400–2483.5 MHz shall use at least 15 hopping channels. The average time of occupancy on any channel shall not be greater than 0.4 seconds within a period of 0.4 seconds, multiplied by the number of hopping channels employed. Transmissions on particular hopping frequencies may be avoided or suppressed provided that at least 15 hopping channels are used.

8.3.2 Test summary

Verdict	Pass				
Test date	July 22, 2016	Test engineer	Andrey Adelberg		
Temperature	22 °C	Relative humidity	49 %	Air pressure	1006 mbar

8.3.3 Notes

The EUT was set to transmit in **BT mode**.

8.3.4 Setup details

Spectrum analyser settings for carrier frequency separation:

Resolution bandwidth	100 kHz
Video bandwidth	≥ RBW
Frequency span	wide enough to capture the peaks of two adjacent channels
Detector mode	Peak
Trace mode	Max Hold

Spectrum analyser settings for number of hopping frequencies:

Resolution bandwidth	100 kHz
Video bandwidth	≥ RBW
Frequency span	the frequency band of operation
Detector mode	Peak
Trace mode	Max Hold

Spectrum analyser settings for time of occupancy (dwell time):

Resolution bandwidth	1 MHz
Video bandwidth	≥ RBW
Frequency span	Zero span
Detector mode	Peak
Trace mode	Max Hold

Spectrum analyser settings for 20 dB bandwidth:

Resolution bandwidth	30 kHz
Video bandwidth	≥ RBW
Frequency span	3 MHz
Detector mode	Peak
Trace mode	Max Hold

8.3.5 Test data

Table 8.3-1: 20 dB bandwidth results

Frequency, MHz	20 dB bandwidth, MHz
2402	0.897
2441	0.897
2480	0.897

Table 8.3-2: Carrier frequency separation results

Carrier frequency separation, MHz	Minimum limit, MHz	Margin, MHz
1.00	0.897	0.103

Table 8.3-3: Number of hopping frequencies and system RF BW results

Number of hopping frequencies	Minimum limit	Margin	System RF bandwidth, MHz
79	15	64	70.94

Note: System RF bandwidth = Number of hopping frequencies × 20 dB bandwidth

Table 8.3-4: Average time of occupancy results

Dwell time of each pulse, ms	Number of pulses within period	Total dwell time within period, ms	Limit, ms	Margin, ms
0.379	320	121.28	400.00	278.72

Notes: Measurement Period is 79 channels × 0.4 s = 31.6 s; Pulse repetition is 98.88 ms; Number of pulses within period = measurement period ÷ pulse repetition.

8.3.5 Test data, continued

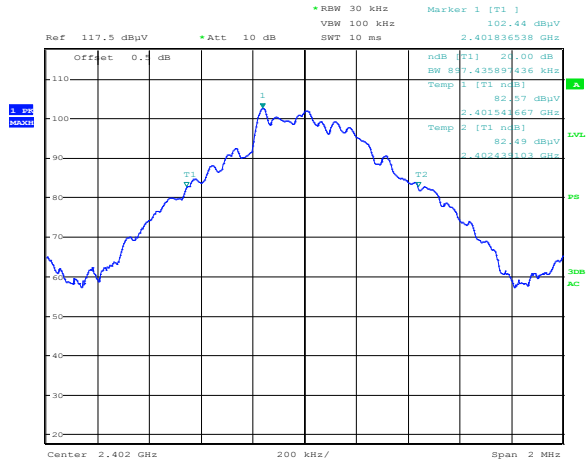

Date: 22.JUL.2016 16:14:28

Figure 8.3-1: 20 dB bandwidth on low channel

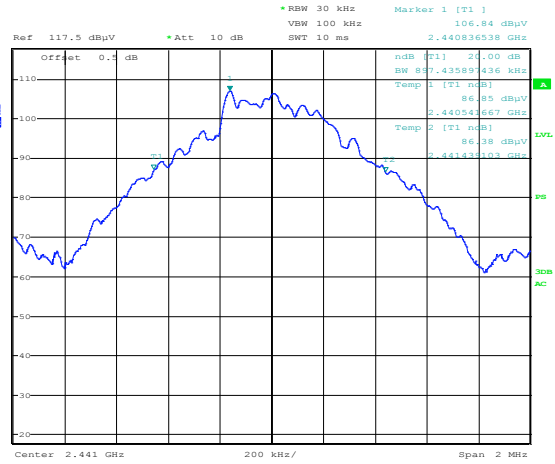

Date: 22.JUL.2016 16:17:12

Figure 8.3-2: 20 dB bandwidth on mid channel

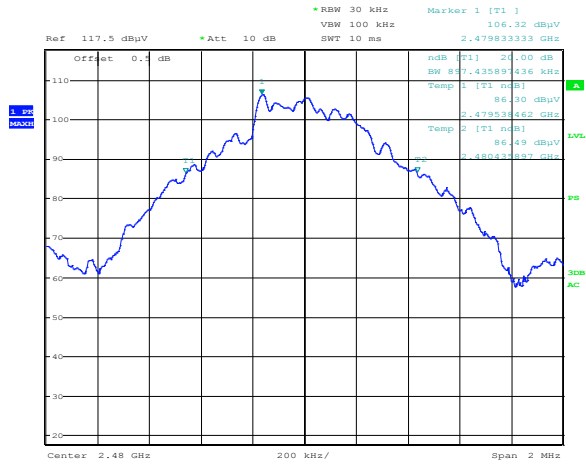

Date: 22.JUL.2016 16:18:01

Figure 8.3-3: 20 dB bandwidth on high channel

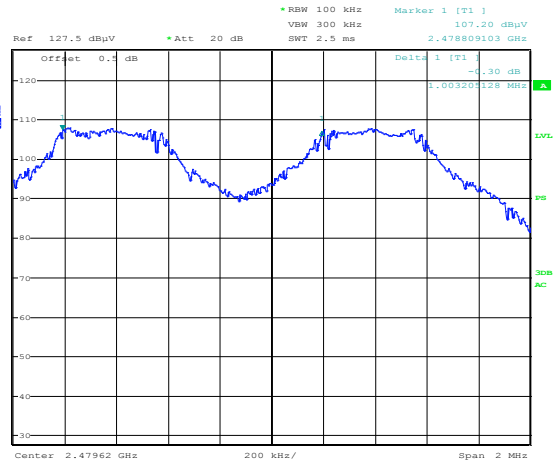

Date: 22.JUL.2016 16:20:31

Figure 8.3-4: Carrier frequency separation

8.3.5 Test data, continued

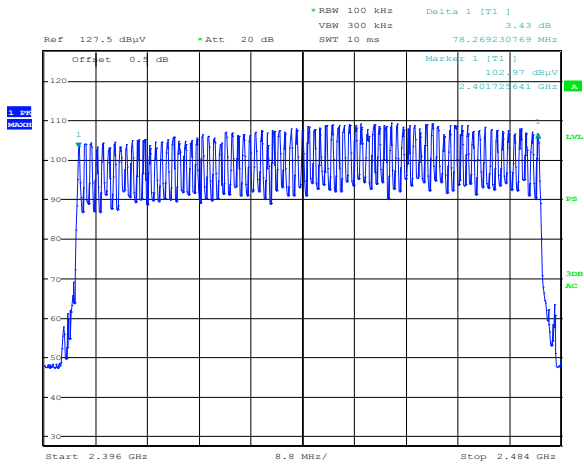

Date: 22.JUL.2016 16:22:04

Figure 8.3-5: Number of hopping channels

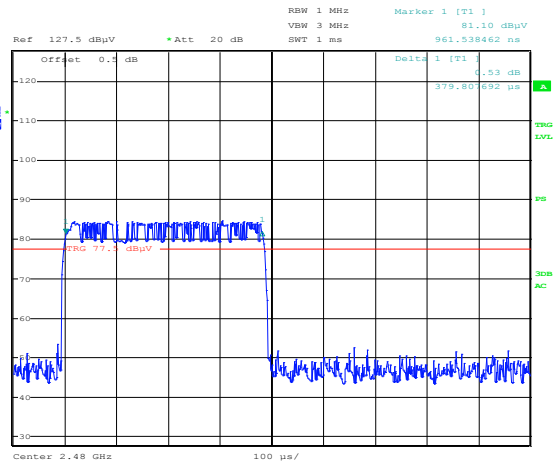

Date: 22.JUL.2016 16:23:20

Figure 8.3-6: Dwell time

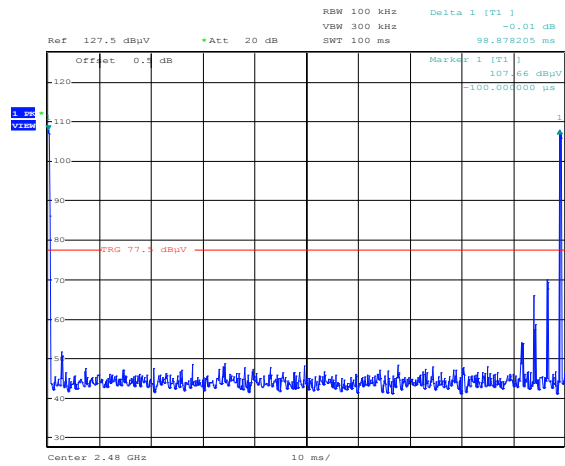

Date: 22.JUL.2016 16:24:09

Figure 8.3-7: Pulse repetition

8.4 FCC 15.247(b) and RSS-247 5.4 (4) Transmitter output power and e.i.r.p. requirements (DTS-BLE)

8.4.1 Definitions and limits

FCC §15.247 (b)(3,4):

- (b) The maximum peak conducted output power of the intentional radiator shall not exceed the following:
- (3) For systems using digital modulation in the 902–928 MHz, 2400–2483.5 MHz, and 5725–5850 MHz bands: 1 W (30 dBm). As an alternative to a peak power measurement, compliance with the one Watt limit can be based on a measurement of the maximum conducted output power. Maximum Conducted Output Power is defined as the total transmit power delivered to all antennas and antenna elements averaged across all symbols in the signaling alphabet when the transmitter is operating at its maximum power control level. Power must be summed across all antennas and antenna elements. The average must not include any time intervals during which the transmitter is off or is transmitting at a reduced power level. If multiple modes of operation are possible (e.g., alternative modulation methods), the maximum conducted output power is the highest total transmit power occurring in any mode.
 - (4) The conducted output power limit specified in paragraph (b) of this section is based on the use of antennas with directional gains that do not exceed 6 dBi. Except as shown in paragraph (c) of this section, if transmitting antennas of directional gain greater than 6 dBi are used, the conducted output power from the intentional radiator shall be reduced below the stated values in paragraphs (b)(1), (b)(2), and (b)(3) of this section, as appropriate, by the amount in dB that the directional gain of the antenna exceeds 6 dBi.

RSS-247, Clause 5.4 (4):

For DTSs employing digital modulation techniques operating in the bands 902–928 MHz and 2400–2483.5 MHz, the maximum peak conducted output power shall not exceed 1W. Except as provided in Section 5.4(5), the e.i.r.p. shall not exceed 4 W.
Fixed point-to-point systems in the bands 2400-2483.5 MHz and 5725-5850 MHz are permitted to have an e.i.r.p. higher than 4 W provided that the higher e.i.r.p. is achieved by employing higher gain directional antennas and not higher transmitter output powers. Point-to-multipoint systems, omnidirectional applications and multiple co-located transmitters transmitting the same information are prohibited from exceeding an e.i.r.p. of 4 W.

8.4.2 Test summary

Verdict	Pass				
Test date	July 20, 2016	Test engineer	David Duchesne		
Temperature	21.7 °C	Relative humidity	49 %	Air pressure	1010 mbar

8.4.3 Notes

- EUT was set to transmit in **BLE mode**.
- The test was performed according to 558074 D01 DTS Meas Guidance v03r05 (The test was performed using method described in Section 9.1.1: Maximum peak conducted output power.)

8.4.4 Setup details

Spectrum analyser settings:

Resolution bandwidth	3 MHz
Video bandwidth	≥3 × RBW
Frequency span	20 MHz
Detector mode	Peak
Trace mode	Max Hold

8.4.5 Test data

Table 8.4-1: Output power measurements results

Frequency, MHz	Conducted output power, dBm		Margin, dB	Antenna gain, dBi	EIRP, dBm	EIRP limit, dBm	EIRP margin, dB
	Measured	Limit					
2402	4.77	30.00	25.23	1.50	6.27	36.00	29.73
2441	6.08	30.00	23.92	1.50	7.58	36.00	28.42
2480	7.20	30.00	22.80	1.50	8.70	36.00	27.30

Notes: EIRP = Output power + Antenna gain

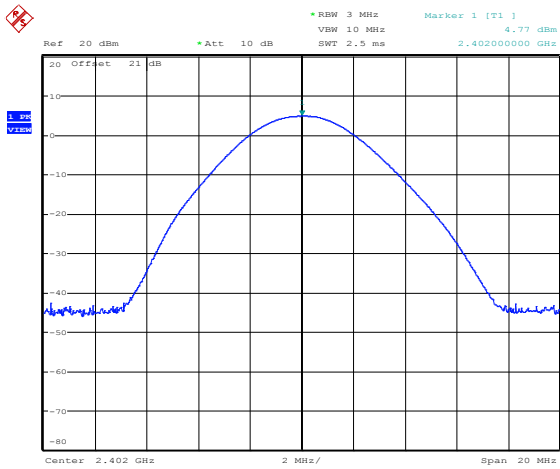

Figure 8.4-1: Output power on low channel

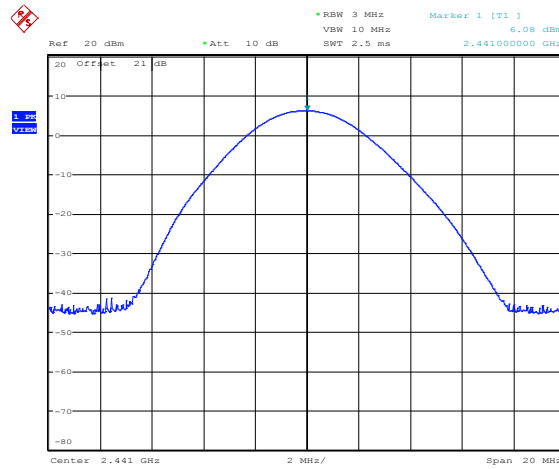

Figure 8.4-2: Output power on mid channel

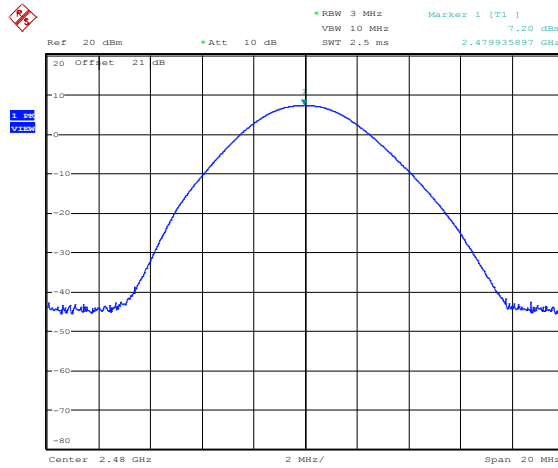

Figure 8.4-3: Output power on high channel

8.5 FCC 15.247(b) and RSS-247 5.4 (2) Transmitter output power and e.i.r.p. requirements (FHSS-BT)

8.5.1 Definitions and limits

FCC §15.247 (b)(1,4):

- (b) The maximum peak conducted output power of the intentional radiator shall not exceed the following:
- (1) For frequency hopping systems operating in the 2400–2483.5 MHz band employing at least 75 non-overlapping hopping channels, and all frequency hopping systems in the 5725–5850 MHz band: 1 watt (30 dBm). For all other frequency hopping systems in the 2400–2483.5 MHz band: 0.125 watts (21 dBm).
 - (4) The conducted output power limit specified in paragraph (b) of this section is based on the use of antennas with directional gains that do not exceed 6 dBi. Except as shown in paragraph (c) of this section, if transmitting antennas of directional gain greater than 6 dBi are used, the conducted output power from the intentional radiator shall be reduced below the stated values in paragraphs (b)(1), (b)(2), and (b)(3) of this section, as appropriate, by the amount in dB that the directional gain of the antenna exceeds 6 dBi.

RSS-247, Clause 5.4 (2):

For FHSS operating in the band 2400–2483.5 MHz, the maximum peak conducted output power shall not exceed 1.0 W (30 dBm) and the e.i.r.p. shall not exceed 4 W (36 dBm) if the hopset uses 75 or more hopping channels; the maximum peak conducted output power shall not exceed 0.125 W (21 dBm) and the e.i.r.p. shall not exceed 0.5 W (27 dBm) if the hopset uses less than 75 hopping channels.

8.5.2 Test summary

Verdict	Pass				
Test date	July 22, 2016	Test engineer	Andrey Adelberg		
Temperature	21.7 °C	Relative humidity	49 %	Air pressure	1010 mbar

8.5.3 Notes

- EUT was set to transmit in **BT mode**.
 - The test was performed according to DA 00-705.
- EUT has a hopset that uses more than 75 hopping channels, hence the output power limit is 1 W.

8.5.4 Setup details

Spectrum analyser settings

Resolution bandwidth	3 MHz
Video bandwidth	≥ RBW
Frequency span	20 MHz
Detector mode	Peak
Trace mode	Max Hold



8.5.5 Test data

Table 8.5-1: Output power and EIRP results for ACL link type with Basic data rate

Packet type	Frequency, MHz	Output power, dBm	Output power limit, dBm	Margin, dB	Antenna gain, dBi	EIRP, dBm	EIRP limit, dBm	EIRP margin, dB
DM1	2402	4.16	30.00	25.84	1.50	5.66	36.00	30.34
DM1	2440	6.95	30.00	23.05	1.50	8.45	36.00	27.55
DM1	2480	7.22	30.00	22.78	1.50	8.72	36.00	27.28
DM3	2402	4.13	30.00	25.87	1.50	5.63	36.00	30.37
DM3	2440	6.95	30.00	23.05	1.50	8.45	36.00	27.55
DM3	2480	7.18	30.00	22.82	1.50	8.68	36.00	27.32
DH3	2402	4.13	30.00	25.87	1.50	5.63	36.00	30.37
DH3	2440	6.95	30.00	23.05	1.50	8.45	36.00	27.55
DH3	2480	7.15	30.00	22.85	1.50	8.65	36.00	27.35
DM5	2402	4.10	30.00	25.90	1.50	5.60	36.00	30.40
DM5	2440	6.95	30.00	23.05	1.50	8.45	36.00	27.55
DM5	2480	7.18	30.00	22.82	1.50	8.68	36.00	27.32
DH5	2402	4.13	30.00	25.87	1.50	5.63	36.00	30.37
DH5	2440	6.95	30.00	23.05	1.50	8.45	36.00	27.55
DH5	2480	7.20	30.00	22.80	1.50	8.70	36.00	27.30
DH1	2402	4.17	30.00	25.83	1.50	5.67	36.00	30.33
DH1	2440	6.95	30.00	23.05	1.50	8.45	36.00	27.55
DH1	2480	7.29	30.00	22.71	1.50	8.79	36.00	27.21
2-DH1	2402	4.93	30.00	25.07	1.50	6.43	36.00	29.57
2-DH1	2440	6.95	30.00	23.05	1.50	8.45	36.00	27.55
2-DH1	2480	7.53	30.00	22.47	1.50	9.03	36.00	26.97
3-DH1	2402	5.13	30.00	24.87	1.50	6.63	36.00	29.37
3-DH1	2440	6.95	30.00	23.05	1.50	8.45	36.00	27.55
3-DH1	2480	7.64	30.00	22.36	1.50	9.14	36.00	26.86

Notes: EIRP = Output power + Antenna gain

Table 8.5-2: Output power and EIRP results for ACL link type with EDR data rate

Packet type	Frequency, MHz	Output power, dBm	Output power limit, dBm	Margin, dB	Antenna gain, dBi	EIRP, dBm	EIRP limit, dBm	EIRP margin, dB
DM1	2402	4.23	30.00	25.77	1.50	5.73	36.00	30.27
DM1	2440	6.96	30.00	23.04	1.50	8.46	36.00	27.54
DM1	2480	7.25	30.00	22.75	1.50	8.75	36.00	27.25
2-DH3	2402	4.87	30.00	25.13	1.50	6.37	36.00	29.63
2-DH3	2440	6.96	30.00	23.04	1.50	8.46	36.00	27.54
2-DH3	2480	7.58	30.00	22.42	1.50	9.08	36.00	26.92
3-DH3	2402	5.13	30.00	24.87	1.50	6.63	36.00	29.37
3-DH3	2440	6.95	30.00	23.05	1.50	8.45	36.00	27.55
3-DH3	2480	7.61	30.00	22.39	1.50	9.11	36.00	26.89
2-DH5	2402	4.88	30.00	25.12	1.50	6.38	36.00	29.62
2-DH5	2440	6.95	30.00	23.05	1.50	8.45	36.00	27.55
2-DH5	2480	7.46	30.00	22.54	1.50	8.96	36.00	27.04
3-DH5	2402	5.10	30.00	24.90	1.50	6.60	36.00	29.40
3-DH5	2440	6.96	30.00	23.04	1.50	8.46	36.00	27.54
3-DH5	2480	7.60	30.00	22.40	1.50	9.10	36.00	26.90

Notes: EIRP = Output power + Antenna gain



Table 8.5-3: Output power and EIRP results for SCO link type with Basic data rate

Packet type	Frequency, MHz	Output power, dBm	Output power limit, dBm	Margin, dB	Antenna gain, dBi	EIRP, dBm	EIRP limit, dBm	EIRP margin, dB
HV1	2402	4.17	30.00	25.83	1.50	5.67	36.00	30.33
HV1	2440	6.96	30.00	23.04	1.50	8.46	36.00	27.54
HV1	2480	7.20	30.00	22.80	1.50	8.70	36.00	27.30
HV2	2402	4.17	30.00	25.83	1.50	5.67	36.00	30.33
HV2	2440	6.96	30.00	23.04	1.50	8.46	36.00	27.54
HV2	2480	7.22	30.00	22.78	1.50	8.72	36.00	27.28
HV3	2402	4.18	30.00	25.82	1.50	5.68	36.00	30.32
HV3	2440	6.96	30.00	23.04	1.50	8.46	36.00	27.54
HV3	2480	7.24	30.00	22.76	1.50	8.74	36.00	27.26
DV	2402	4.20	30.00	25.80	1.50	5.70	36.00	30.30
DV	2440	6.97	30.00	23.03	1.50	8.47	36.00	27.53
DV	2480	7.22	30.00	22.78	1.50	8.72	36.00	27.28

Notes: EIRP = Output power + Antenna gain

Table 8.5-4: Output power and EIRP results for eSCO link type with Basic data rate

Packet type	Frequency, MHz	Output power, dBm	Output power limit, dBm	Margin, dB	Antenna gain, dBi	EIRP, dBm	EIRP limit, dBm	EIRP margin, dB
EV3	2402	4.22	30.00	25.78	1.50	5.72	36.00	30.28
EV3	2440	6.95	30.00	23.05	1.50	8.45	36.00	27.55
EV3	2480	7.25	30.00	22.75	1.50	8.75	36.00	27.25
EV4	2402	4.17	30.00	25.83	1.50	5.67	36.00	30.33
EV4	2440	6.95	30.00	23.05	1.50	8.45	36.00	27.55
EV4	2480	7.21	30.00	22.79	1.50	8.71	36.00	27.29
EV5	2402	4.17	30.00	25.83	1.50	5.67	36.00	30.33
EV5	2440	6.97	30.00	23.03	1.50	8.47	36.00	27.53
EV5	2480	7.22	30.00	22.78	1.50	8.72	36.00	27.28

Notes: EIRP = Output power + Antenna gain

Table 8.5-5: Output power and EIRP results for eSCO link type with EDR data rate

Packet type	Frequency, MHz	Output power, dBm	Output power limit, dBm	Margin, dB	Antenna gain, dBi	EIRP, dBm	EIRP limit, dBm	EIRP margin, dB
2-EV3	2402	4.84	30.00	25.16	1.50	6.34	36.00	29.66
2-EV3	2440	6.96	30.00	23.04	1.50	8.46	36.00	27.54
2-EV3	2480	7.48	30.00	22.52	1.50	8.98	36.00	27.02
3-EV3	2402	5.16	30.00	24.84	1.50	6.66	36.00	29.34
3-EV3	2440	6.96	30.00	23.04	1.50	8.46	36.00	27.54
3-EV3	2480	7.63	30.00	22.37	1.50	9.13	36.00	26.87
2-EV5	2402	4.91	30.00	25.09	1.50	6.41	36.00	29.59
2-EV5	2440	6.98	30.00	23.02	1.50	8.48	36.00	27.52
2-EV5	2480	7.48	30.00	22.52	1.50	8.98	36.00	27.02
3-EV5	2402	5.10	30.00	24.90	1.50	6.60	36.00	29.40
3-EV5	2440	6.94	30.00	23.06	1.50	8.44	36.00	27.56
3-EV5	2480	7.60	30.00	22.40	1.50	9.10	36.00	26.90

Notes: EIRP = Output power + Antenna gain

Section 8
Test name
Specification

Testing data
FCC 15.247(b) and RSS-247 5.4 (2) Transmitter output power and e.i.r.p. requirements (FHSS-BT)
FCC Part 15 Subpart C and RSS-247, Issue 1

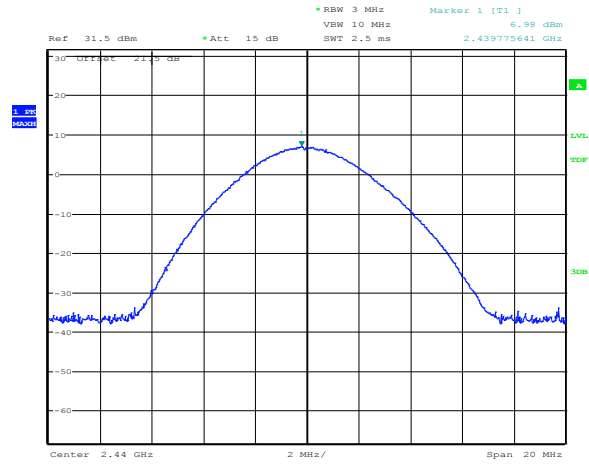

Date: 7.NOV.2016 16:27:44

Figure 8.5-1: Output power sample plot

8.6 FCC 15.247(d) and RSS-247 5.5 Spurious (out-of-band) emissions

8.6.1 Definitions and limits

FCC §15.247 (d):

In any 100 kHz bandwidth outside the frequency band in which the spread spectrum or digitally modulated intentional radiator is operating, the radio frequency power that is produced by the intentional radiator shall be at least 20 dB below that in the 100 kHz bandwidth within the band that contains the highest level of the desired power, based on either an RF conducted or a radiated measurement, provided the transmitter demonstrates compliance with the peak conducted power limits. If the transmitter complies with the conducted power limits based on the use of RMS averaging over a time interval, as permitted under paragraph (b)(3) of this section, the attenuation required under this paragraph shall be 30 dB instead of 20 dB. Attenuation below the general limits specified in §15.209(a) is not required. In addition, radiated emissions which fall in the restricted bands, as defined in §15.205(a), must also comply with the radiated emission limits specified in §15.209(a) (see §15.205(c)).

RSS-247, Clause 5.5:

In any 100 kHz bandwidth outside the frequency band in which the spread spectrum or digitally modulated device is operating, the RF power that is produced shall be at least 20 dB below that in the 100 kHz bandwidth within the band that contains the highest level of the desired power, based on either an RF conducted or a radiated measurement, provided that the transmitter demonstrates compliance with the peak conducted power limits. If the transmitter complies with the conducted power limits based on the use of root-mean-square averaging over a time interval, as permitted under Section 5.4(4), the attenuation required shall be 30 dB instead of 20 dB. Attenuation below the general field strength limits specified in RSS-Gen is not required.

Table 8.6-1: FCC §15.209 and RSS-Gen – Radiated emission limits

Frequency, MHz	Field strength of emissions		Measurement distance, m
	µV/m	dBµV/m	
0.009–0.490	2400/F	$67.6 - 20 \times \log_{10}(F)$	300
0.490–1.705	24000/F	$87.6 - 20 \times \log_{10}(F)$	30
1.705–30.0	30	29.5	30
30–88	100	40.0	3
88–216	150	43.5	3
216–960	200	46.0	3
above 960	500	54.0	3

Notes: In the emission table above, the tighter limit applies at the band edges.
 For frequencies above 1 GHz the limit on peak RF emissions is 20 dB above the maximum permitted average emission limit applicable to the equipment under test

Table 8.6-2: IC restricted frequency bands

MHz	MHz	MHz	GHz
0.090–0.110	12.51975–12.52025	399.9–410	5.35–5.46
2.1735–2.1905	12.57675–12.57725	608–614	7.25–7.75
3.020–3.026	13.36–13.41	960–1427	8.025–8.5
4.125–4.128	16.42–16.423	1435–1626.5	9.0–9.2
4.17725–4.17775	16.69475–16.69525	1645.5–1646.5	9.3–9.5
4.20725–4.20775	16.80425–16.80475	1660–1710	10.6–12.7
5.677–5.683	25.5–25.67	1718.8–1722.2	13.25–13.4
6.215–6.218	37.5–38.25	2200–2300	14.47–14.5
6.26775–6.26825	73–74.6	2310–2390	15.35–16.2
6.31175–6.31225	74.8–75.2	2655–2900	17.7–21.4
8.291–8.294	108–138	3260–3267	22.01–23.12
8.362–8.366	156.52475–156.52525	3332–3339	23.6–24.0
8.37625–8.38675	156.7–156.9	3345.8–3358	31.2–31.8
8.41425–8.41475	240–285	3500–4400	36.43–36.5
12.29–12.293	322–335.4	4500–5150	Above 38.6

Notes: Certain frequency bands listed in this table and above 38.6 GHz are designated for low-power licence-exempt applications. These frequency bands and the requirements that apply to the devices are set out in this Standard

Table 8.6-3: FCC restricted frequency bands

MHz	MHz	MHz	GHz
0.090–0.110	16.42–16.423	399.9–410	4.5–5.15
0.495–0.505	16.69475–16.69525	608–614	5.35–5.46
2.1735–2.1905	16.80425–16.80475	960–1240	7.25–7.75
4.125–4.128	25.5–25.67	1300–1427	8.025–8.5
4.17725–4.17775	37.5–38.25	1435–1626.5	9.0–9.2
4.20725–4.20775	73–74.6	1645.5–1646.5	9.3–9.5
6.215–6.218	74.8–75.2	1660–1710	10.6–12.7
6.26775–6.26825	108–121.94	1718.8–1722.2	13.25–13.4
6.31175–6.31225	123–138	2200–2300	14.47–14.5
8.291–8.294	149.9–150.05	2310–2390	15.35–16.2
8.362–8.366	156.52475–156.52525	2483.5–2500	17.7–21.4
8.37625–8.38675	156.7–156.9	2690–2900	22.01–23.12
8.41425–8.41475	162.0125–167.17	3260–3267	23.6–24.0
12.29–12.293	167.72–173.2	3332–3339	31.2–31.8
12.51975–12.52025	240–285	3345.8–3358	36.43–36.5
12.57675–12.57725	322–335.4	3600–4400	Above 38.6
13.36–13.41			

8.6.2 Test summary

Verdict	Pass		
Test date	July 19, 2016	Test engineer	David Duchesne
Temperature	22 °C	Relative humidity	49 %
		Air pressure	1006 mbar

8.6.3 Notes

- The spectrum was searched from 30 MHz to the 10th harmonic.
- Since fundamental power was tested using peak method, the spurious emissions limit is –20 dBc/100 kHz
- The radiated spectral plot is a summation of a vertical and horizontal scan. The spectral scan has been corrected with the associated transducer factors (i.e. antenna factors, cable loss, amplifier gains, and attenuators).

8.6.4 Setup details

Spectrum analyser settings for conducted measurements:

Resolution bandwidth:	100 kHz
Video bandwidth:	300 kHz
Detector mode:	Peak
Trace mode:	Max Hold

Spectrum analyser settings for radiated measurements within restricted bands below 1 GHz:

Resolution bandwidth:	100 kHz
Video bandwidth:	300 kHz
Detector mode:	Peak
Trace mode:	Max Hold

Spectrum analyser settings for peak radiated measurements within restricted bands above 1 GHz:

Resolution bandwidth:	1 MHz
Video bandwidth:	3 MHz
Detector mode:	Peak
Trace mode:	Max Hold

Spectrum analyser settings for average radiated measurements within restricted bands above 1 GHz:

Resolution bandwidth:	1 MHz
Video bandwidth:	10 Hz
Detector mode:	Peak
Trace mode:	Max Hold

8.6.5 Test data

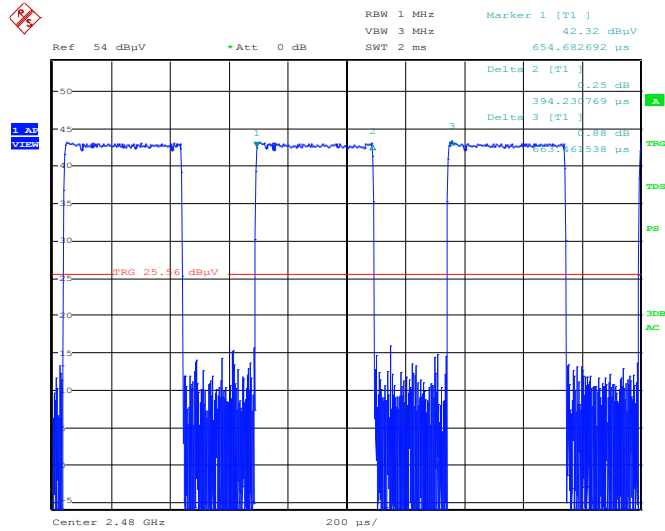
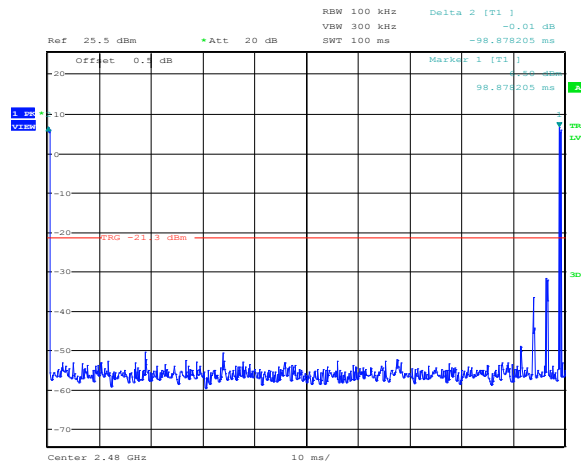

Figure 8.6-1: Pulse width for BLE

BLE Duty Cycle Calculation:

Tx on Time: 0.394 ms; T period = 0.663 ms; Tx off time = 0.269 ms (0.663 ms – 0.394 ms)

Duty cycle correction factor: $20 \times \log_{10}(0.394 / 0.663) = -4.5 \text{ dB}$



Date: 22.JUL.2016 11:20:44

Figure 8.6-2: Number of pulses for BT (hopping on) within 100 ms time frame

The following plots were taken with hopping sequence turned off.
 With the hopping sequence turned on there are two pulses within 100 ms time frame.

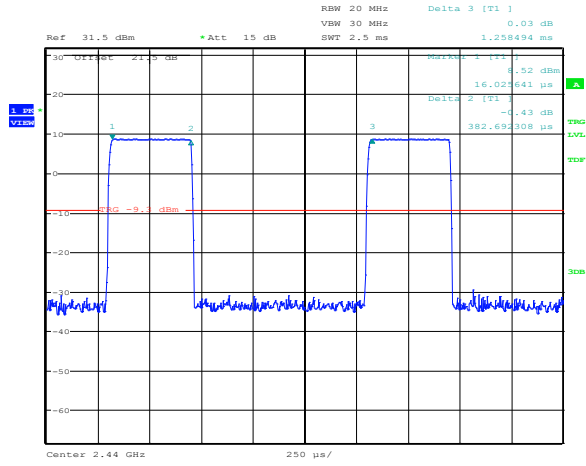

Date: 7.NOV.2016 17:21:45

Figure 8.6-3: Pulse width for DH1

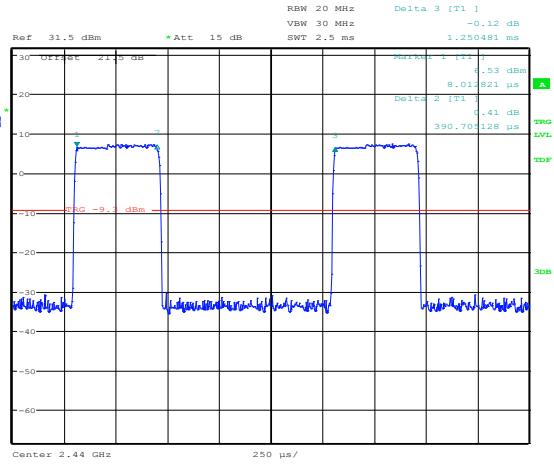

Date: 7.NOV.2016 17:22:47

Figure 8.6-4: Pulse width for 2-DH1

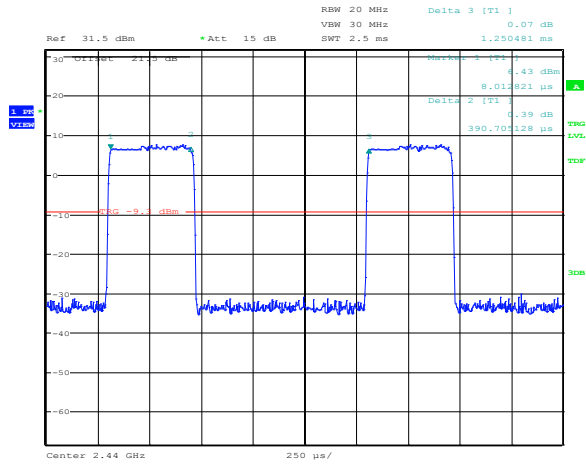

Date: 7.NOV.2016 17:23:14

Figure 8.6-5: Pulse width for 3-DH1

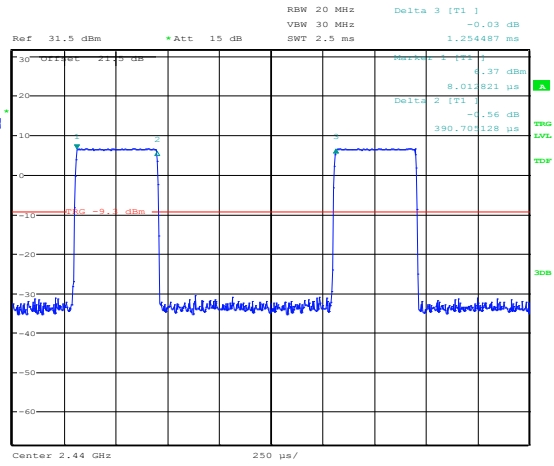

Date: 7.NOV.2016 17:23:43

Figure 8.6-6: Pulse width for DM1 (Basic data rate)

Section 8
Test name
Specification

Testing data
 FCC 15.247(d) and RSS-247 5.5 Spurious (out-of-band) emissions
 FCC Part 15 Subpart C and RSS-247, Issue 1

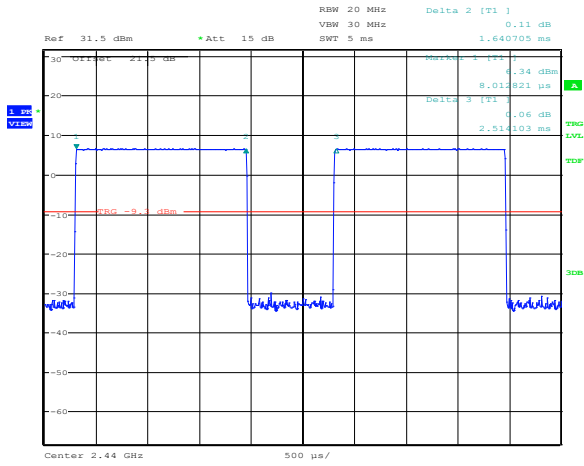

Date: 7.NOV.2016 17:24:22

Figure 8.6-7: Pulse width for DM3

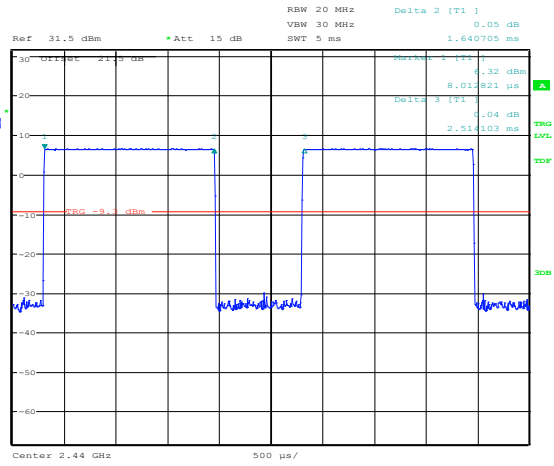

Date: 7.NOV.2016 17:24:48

Figure 8.6-8: Pulse width for DH3

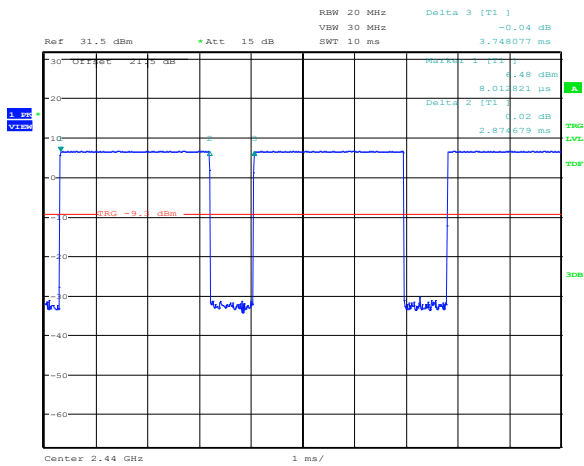

Date: 7.NOV.2016 17:25:27

Figure 8.6-9: Pulse width for DM5

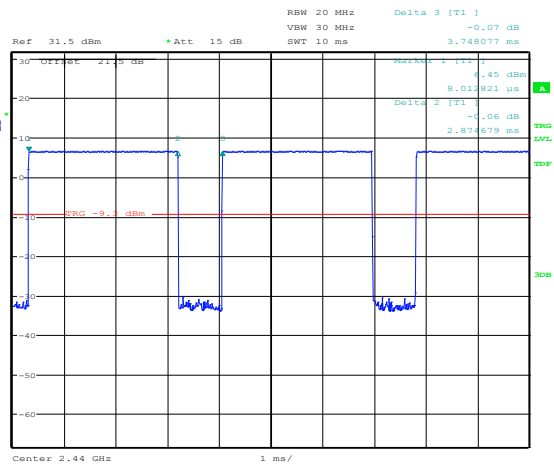

Date: 7.NOV.2016 17:25:58

Figure 8.6-10: Pulse width for DH5

Section 8
Test name
Specification

Testing data
 FCC 15.247(d) and RSS-247 5.5 Spurious (out-of-band) emissions
 FCC Part 15 Subpart C and RSS-247, Issue 1

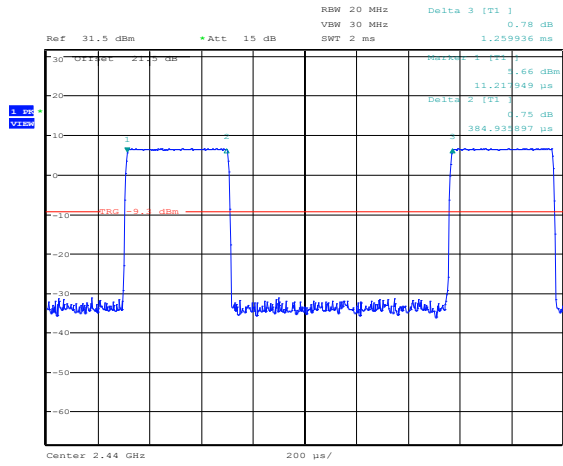

Date: 7.NOV.2016 17:27:08

Figure 8.6-11: Pulse width for DM1 (EDR data rate)

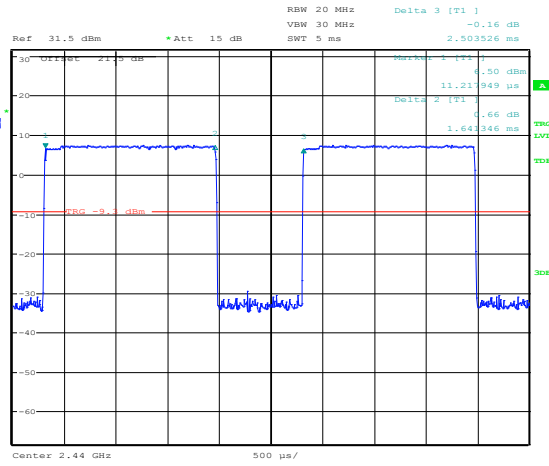

Date: 7.NOV.2016 17:28:09

Figure 8.6-12: Pulse width for 2-DH3

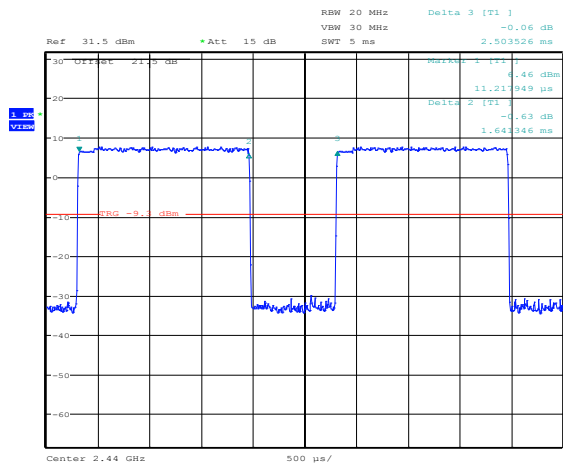

Date: 7.NOV.2016 17:28:40

Figure 8.6-13: Pulse width for 3-DH3

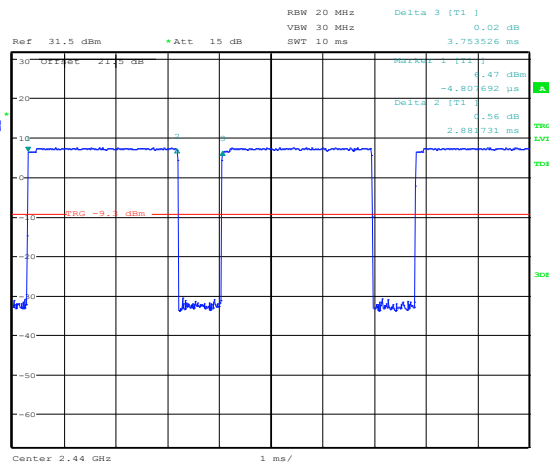

Date: 7.NOV.2016 17:29:25

Figure 8.6-14: Pulse width for 2-DH5

Section 8
Test name
Specification

Testing data
 FCC 15.247(d) and RSS-247 5.5 Spurious (out-of-band) emissions
 FCC Part 15 Subpart C and RSS-247, Issue 1

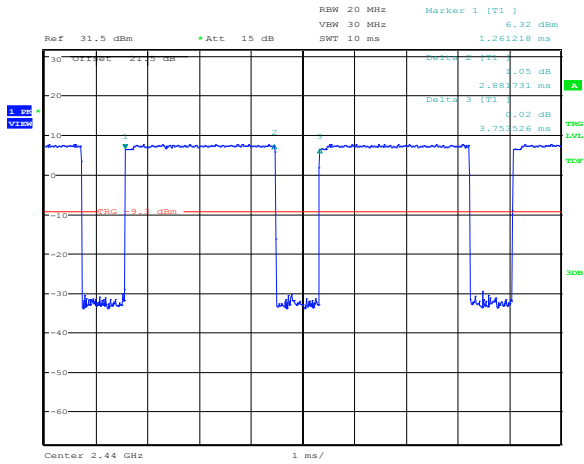

Date: 7.NOV.2016 17:30:10

Figure 8.6-15: Pulse width for 3-DH5

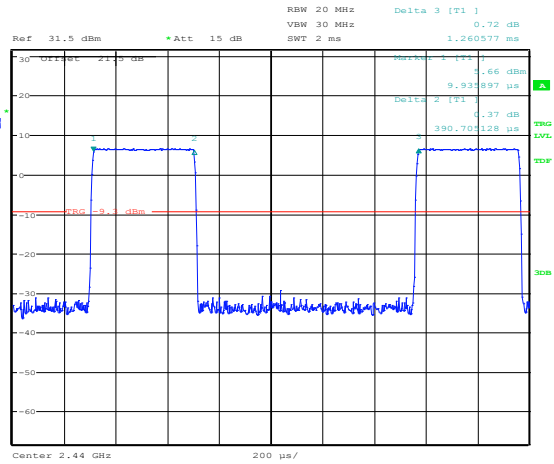

Date: 7.NOV.2016 17:30:55

Figure 8.6-16: Pulse width for HV1

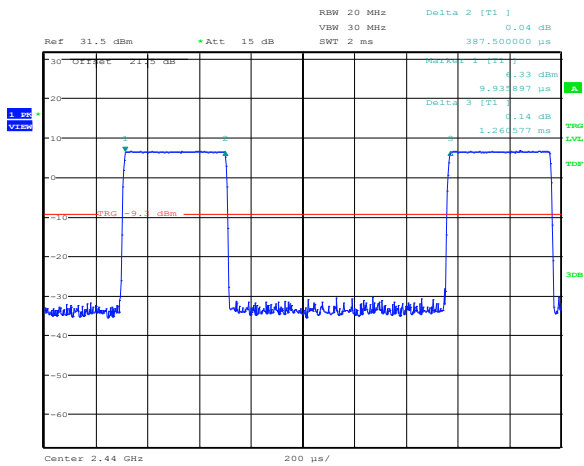

Date: 7.NOV.2016 17:31:25

Figure 8.6-17: Pulse width for HV2

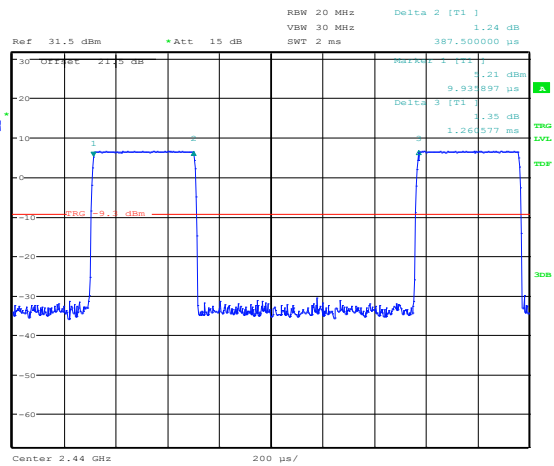

Date: 7.NOV.2016 17:31:48

Figure 8.6-18: Pulse width for HV3

Section 8
Test name
Specification

Testing data
 FCC 15.247(d) and RSS-247 5.5 Spurious (out-of-band) emissions
 FCC Part 15 Subpart C and RSS-247, Issue 1

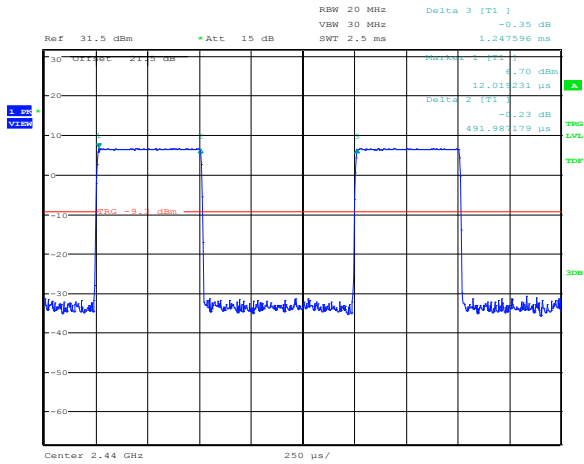

Date: 7.NOV.2016 17:32:54

Figure 8.6-19: Pulse width for DV

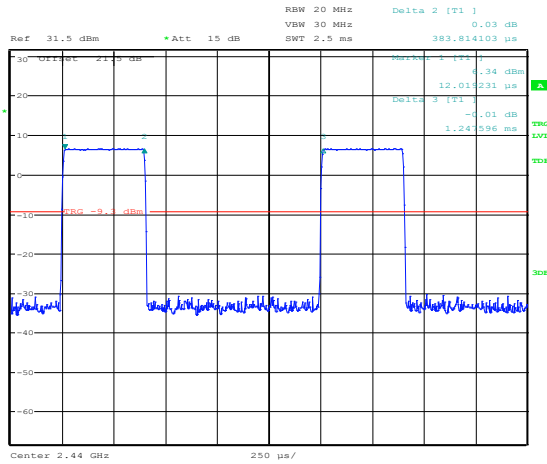

Date: 7.NOV.2016 17:33:24

Figure 8.6-20: Pulse width for EV3

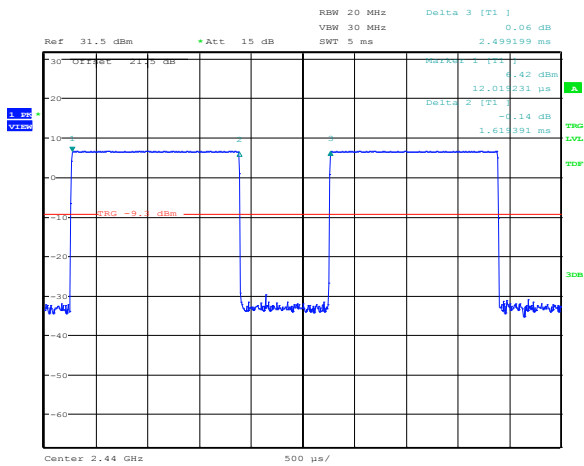

Date: 7.NOV.2016 17:34:02

Figure 8.6-21: Pulse width for EV4

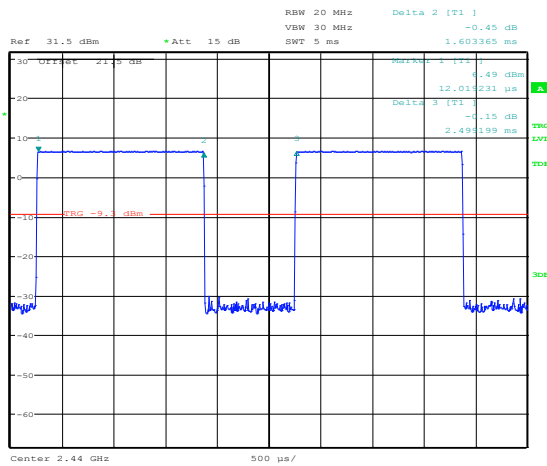

Date: 7.NOV.2016 17:34:28

Figure 8.6-22: Pulse width for EV5

Section 8
Test name
Specification

Testing data
 FCC 15.247(d) and RSS-247 5.5 Spurious (out-of-band) emissions
 FCC Part 15 Subpart C and RSS-247, Issue 1

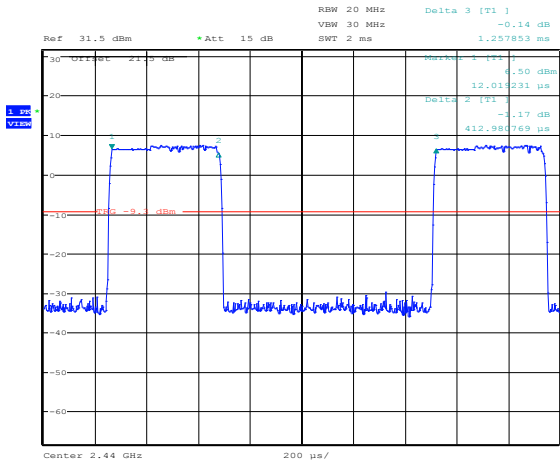

Date: 7.NOV.2016 17:35:05

Figure 8.6-23: Pulse width for 2-EV3

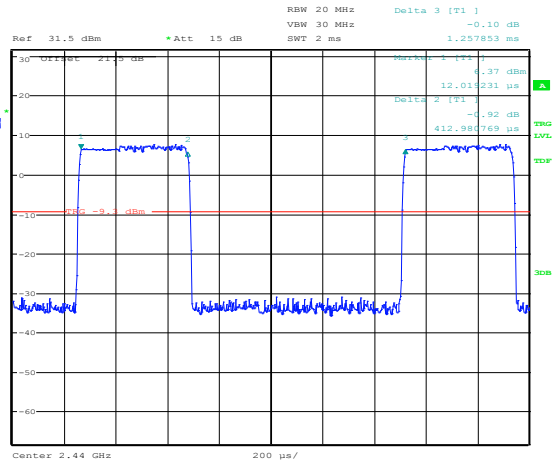

Date: 7.NOV.2016 17:35:29

Figure 8.6-24: Pulse width for 3-EV3

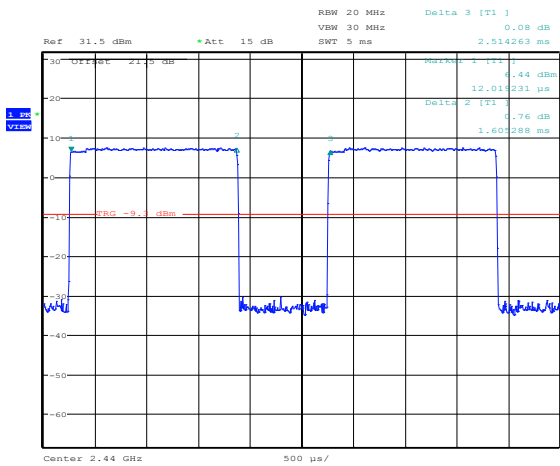

Date: 7.NOV.2016 17:36:03

Figure 8.6-25: Pulse width for 2-EV5

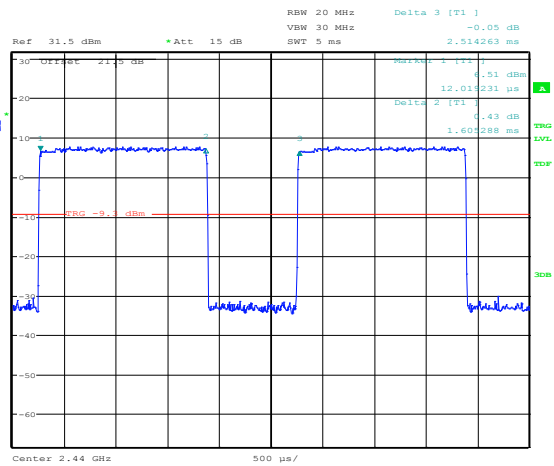

Date: 7.NOV.2016 17:36:25

Figure 8.6-26: Pulse width for 3-EV5



Duty cycle correction factor was calculated as follows:

$$20 \times \text{Log}_{10} \{ (\text{Pulse width (ms)} \times \text{number of pulses within 100 ms}) / 100 \text{ (ms)} \}$$

Table 8.6-4: Output power and EIRP results for ACL link type with Basic data rate

Packet type	Pulse width, ms	Number of pulses within 100 ms	Duty cycle correction factor, dB
DM1	0.391	2	-42.14
DM3	1.641	2	-29.68
DH3	1.641	2	-29.68
DM5	2.875	2	-24.81
DH5	2.875	2	-24.81
DH1	0.383	2	-42.32
2-DH1	0.391	2	-42.14
3-DH1	0.391	2	-42.14

Table 8.6-5: Output power and EIRP results for ACL link type with EDR data rate

Packet type	Pulse width, ms	Number of pulses within 100 ms	Duty cycle correction factor, dB
DM1	0.385	2	-42.27
2-DH3	1.641	2	-29.68
3-DH3	1.641	2	-29.68
2-DH5	2.882	2	-24.79
3-DH5	2.882	2	-24.79

Table 8.6-6: Output power and EIRP results for SCO link type with Basic data rate

Packet type	Pulse width, ms	Number of pulses within 100 ms	Duty cycle correction factor, dB
HV1	0.391	2	-42.14
HV2	0.388	2	-42.20
HV3	0.388	2	-42.20
DV	0.492	2	-40.14

Table 8.6-7: Output power and EIRP results for eSCO link type with Basic data rate

Packet type	Pulse width, ms	Number of pulses within 100 ms	Duty cycle correction factor, dB
EV3	0.384	2	-42.29
EV4	1.619	2	-29.79
EV5	1.603	2	-29.88

Table 8.6-8: Output power and EIRP results for eSCO link type with EDR data rate

Packet type	Pulse width, ms	Number of pulses within 100 ms	Duty cycle correction factor, dB
2-EV3	0.413	2	-41.66
3-EV3	0.413	2	-41.66
2-EV5	1.605	2	-29.87
3-EV5	1.605	2	-29.87

8.6.5 Test data, continued

Table 8.6-9: Radiated field strength measurement results for BT

Channel	Frequency, MHz	Peak Field strength, dB μ V/m		Margin, dB	Average Field strength, dB μ V/m		Margin, dB
		Measured	Limit		Calculated	Limit	
Low	2390	51.72	74.00	22.28	26.93	54.00	27.07
Low	4804	45.20	74.00	28.80	20.41	54.00	33.59
Low	7206	52.47	74.00	21.53	27.68	54.00	26.32
Mid	4882	41.93	74.00	32.07	17.14	54.00	36.86
Mid	7323	54.93	74.00	19.07	30.14	54.00	23.86
High	2483.5	58.78	74.00	15.22	33.99	54.00	20.01
High	4960	44.35	74.00	29.65	19.56	54.00	34.44
High	7440	55.24	74.00	18.76	30.45	54.00	23.55

Notes: Field strength (dB μ V/m) = Spectrum analyzer value (dB μ V) + transducer factors (dB)
 Transducer factors (i.e. antenna factors, cable loss, amplifier gains, and attenuators).
 Average field strength calculation was performed using the following formula: Average Field strength = Peak Field strength + Duty cycle correction factor (DCCF) for BT
 The lowest DCCF (see tables above) was -24.79 dB
 All other emissions were greater than 20 dB below the limit.

Table 8.6-10: Radiated field strength measurement results for BLE

Channel	Frequency, MHz	Peak Field strength, dB μ V/m		Margin, dB	Average Field strength, dB μ V/m		Margin, dB
		Measured	Limit		Calculated	Limit	
Low	2390	51.63	74.00	22.37	47.13	54.00	6.77
Low	4804	43.00	74.00	31.00	38.50	54.00	15.40
Low	7206	51.39	74.00	22.61	46.89	54.00	7.01
Mid	4880	43.31	74.00	30.69	38.81	54.00	15.09
Mid	7320	55.84	74.00	18.16	51.34	54.00	2.56
High	2483.5	58.23	74.00	15.77	53.73	54.00	0.17
High	4960	44.61	74.00	29.39	40.11	54.00	13.79
High	7440	54.80	74.00	19.20	50.30	54.00	3.60

Notes: Field strength (dB μ V/m) = Spectrum analyzer value (dB μ V) + transducer factors (dB)
 Transducer factors (i.e. antenna factors, cable loss, amplifier gains, and attenuators).
 Average field strength calculation was performed using the following formula: Average Field strength = Peak Field strength + Duty cycle correction factor for BLE
 DCCF = -4.5 dB
 All other emissions were greater than 20 dB form limit.

8.6.5 Test data, continued

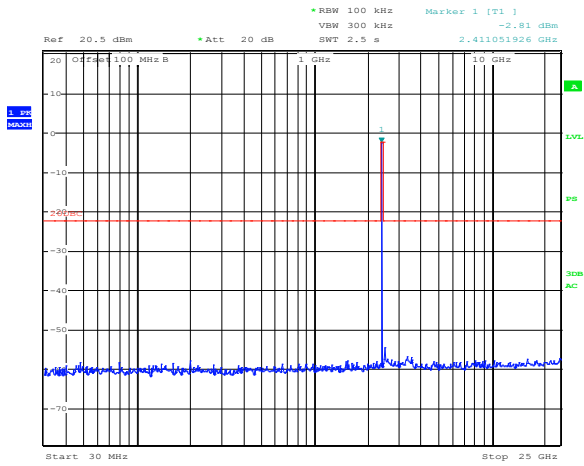

Date: 22.JUL.2016 16:36:28

Figure 8.6-27: Conducted spurious emissions for BT, low channel

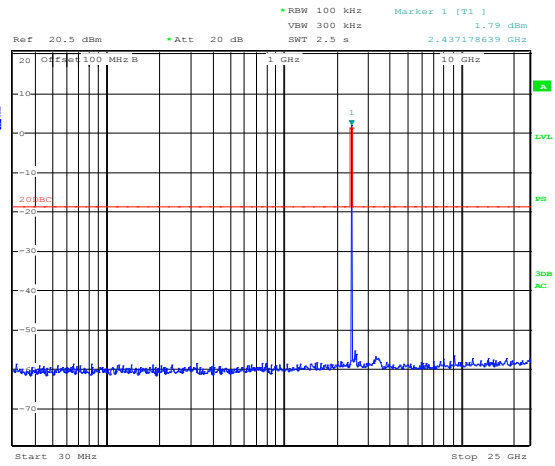

Date: 22.JUL.2016 16:37:34

Figure 8.6-28: Conducted spurious emissions for BT, mid channel

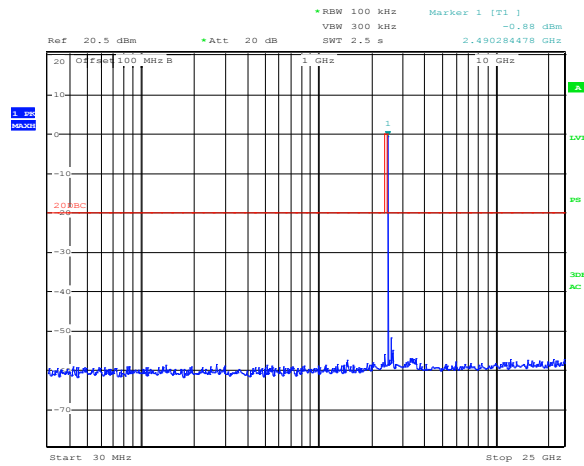

Date: 22.JUL.2016 16:38:44

Figure 8.6-29: Conducted spurious emissions for BT, high channel

8.6.5 Test data, continued

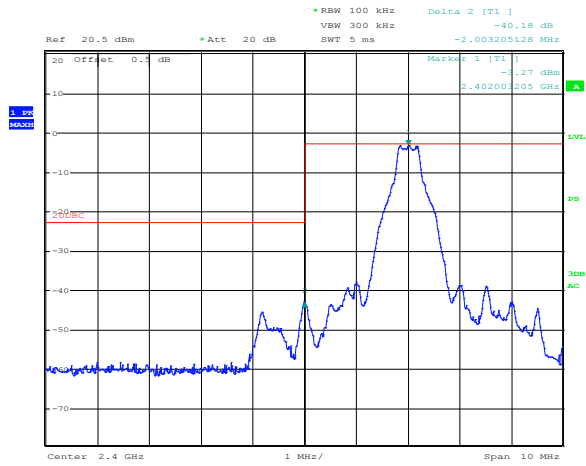

Date: 22.JUL.2016 16:34:36

Figure 8.6-30: Conducted spurious emissions lower band edge for BT, low channel (hopping sequence is off)

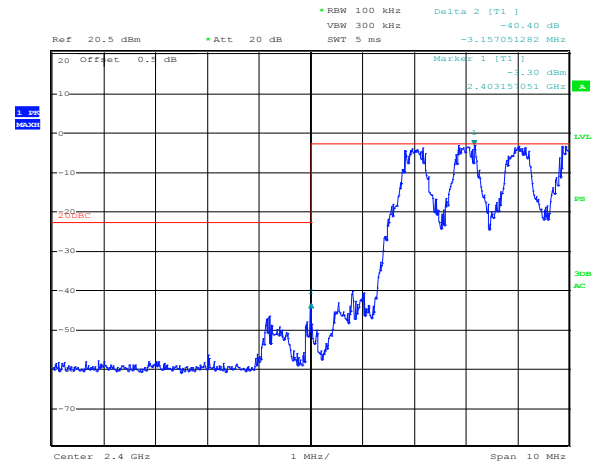

Date: 22.JUL.2016 16:34:03

Figure 8.6-31: Conducted spurious emissions lower band edge for BT, hopping sequence is on

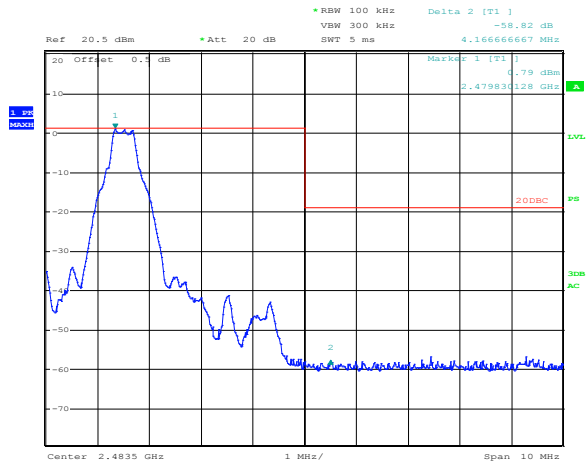

Date: 22.JUL.2016 16:32:12

Figure 8.6-32: Conducted spurious emissions upper band edge for BT, high channel (hopping sequence is off)

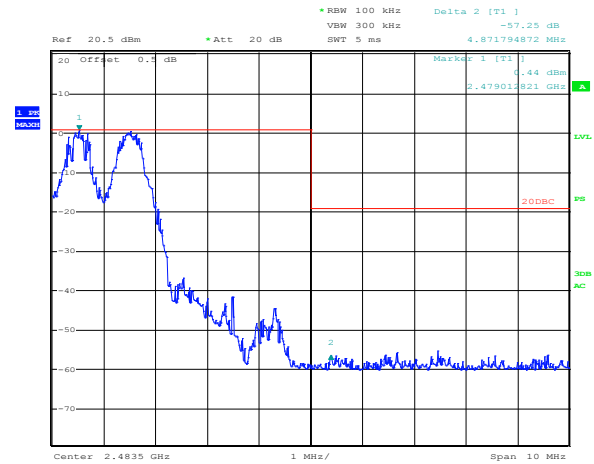

Date: 22.JUL.2016 16:33:16

Figure 8.6-33: Conducted spurious emissions upper band edge for BT, hopping sequence is on

8.6.5 Test data, continued

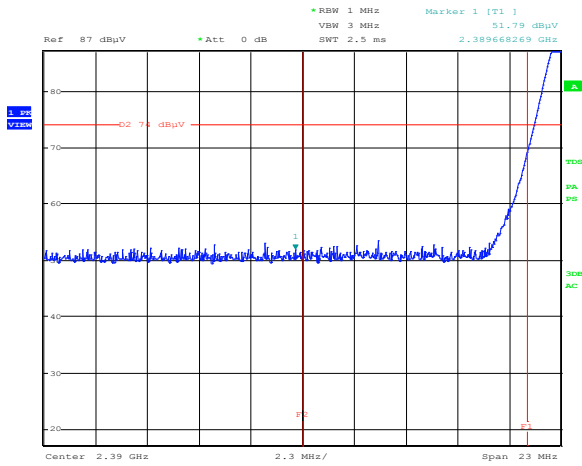

Date: 22.JUL.2016 15:08:44

Figure 8.6-34: Radiated spurious emissions Lower band edge emission for BT, hopping is turned off – Low channel. F2 = 2.39 GHz (end of restricted band), F1 = 2.4 GHz

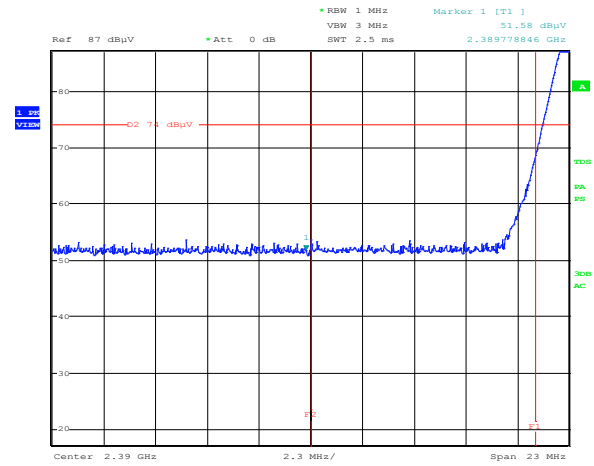

Date: 22.JUL.2016 15:07:24

Figure 8.6-35: Radiated spurious emissions Lower band edge emission for BT, hopping is turned on. F2 = 2.39 GHz (end of restricted band), F1 = 2.4 GHz

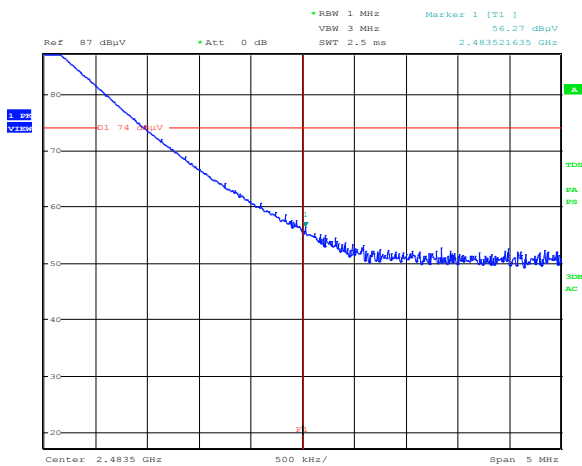

Date: 22.JUL.2016 15:04:50

Figure 8.6-36: Radiated spurious emissions Upper band edge emission for BT, hopping is turned off – high channel. F1 = 2.4835 GHz (beginning of restricted band)

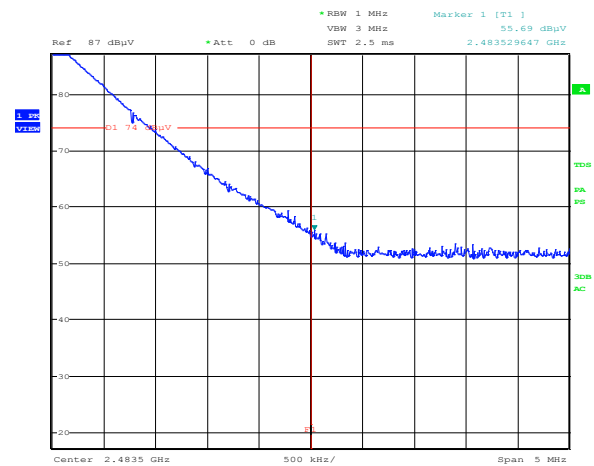

Date: 22.JUL.2016 15:05:52

Figure 8.6-37: Radiated spurious emissions Upper band edge emission for BT, hopping is turned on. F1 = 2.4835 GHz (beginning of restricted band)

8.6.5 Test data, continued

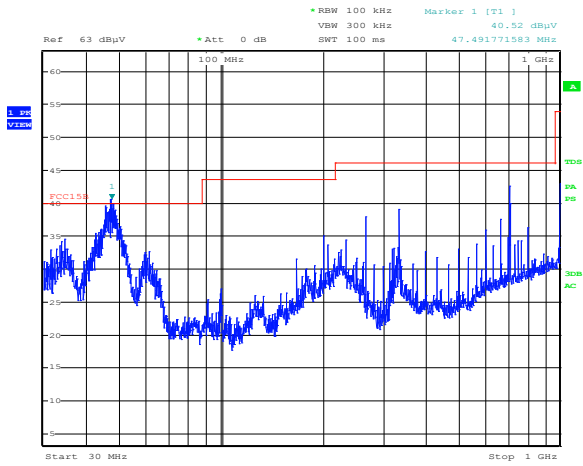

Figure 8.6-38: Radiated spurious emissions for BT, low channel, 30 to 1000 MHz

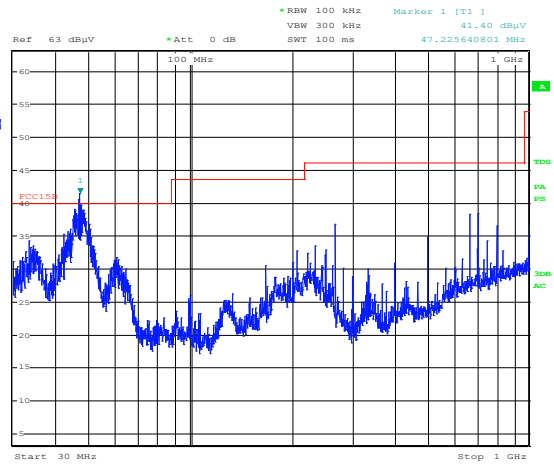

Figure 8.6-39: Radiated spurious emissions for BT, mid channel, 30 to 1000 MHz

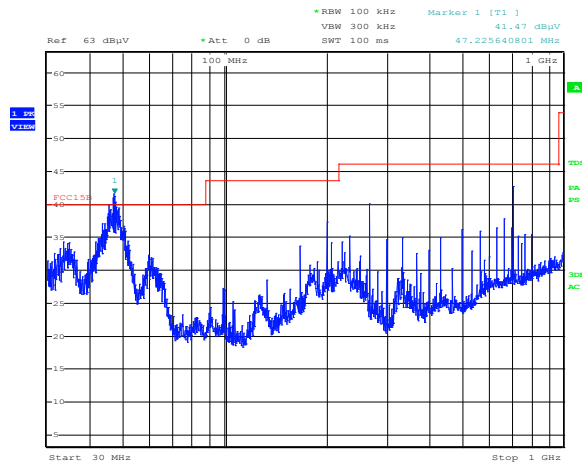

Figure 8.6-40: Radiated spurious emissions for BT, high channel, 30 to 1000 MHz

8.6.5 Test data, continued

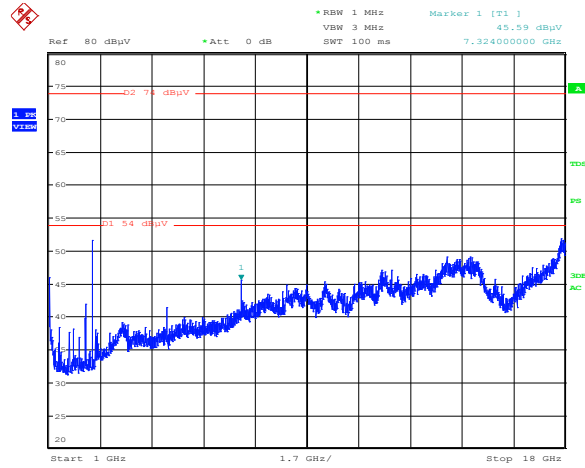
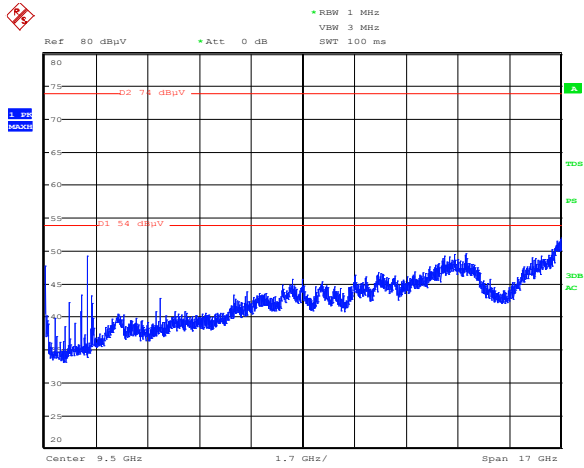

Figure 8.6-41: Radiated spurious emissions for BT, low channel, 1 to 18 GHz

Figure 8.6-42: Radiated spurious emissions for BT, mid channel, 1 to 18 GHz

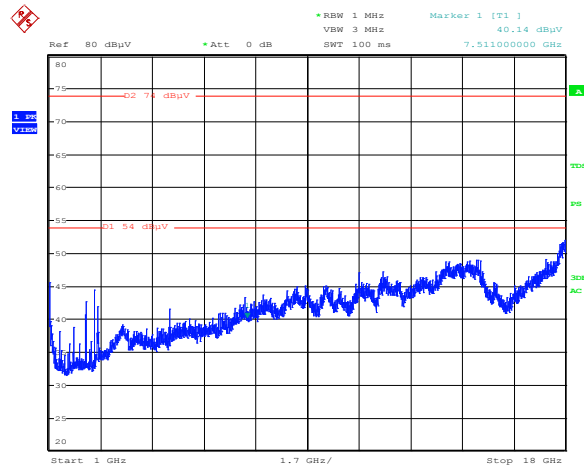

Figure 8.6-43: Radiated spurious emissions for BT, high channel, 1 to 18 GHz

8.6.5 Test data, continued

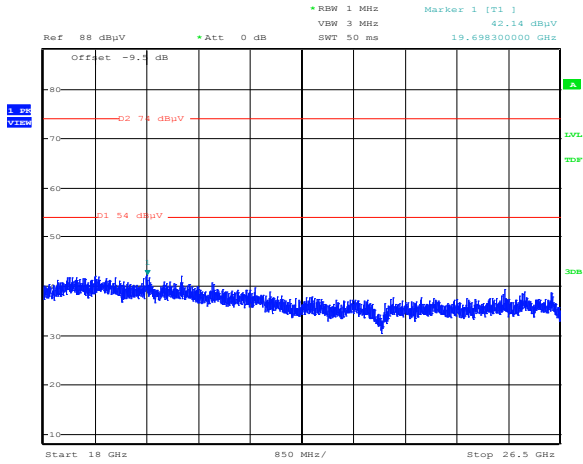

Figure 8.6-44: Radiated spurious emissions for BT, low channel, 18 to 26.5 GHz

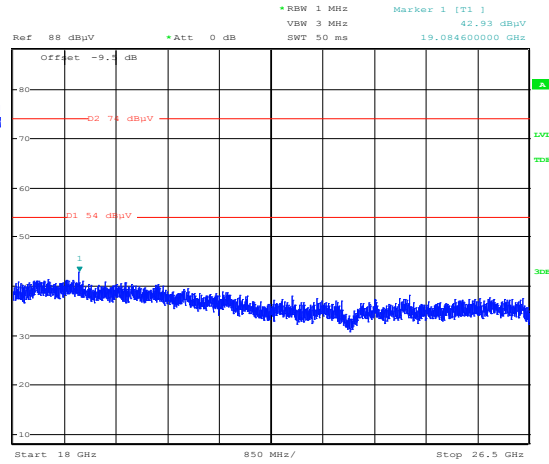

Figure 8.6-45: Radiated spurious emissions for BT, mid channel, 18 to 26.5 GHz

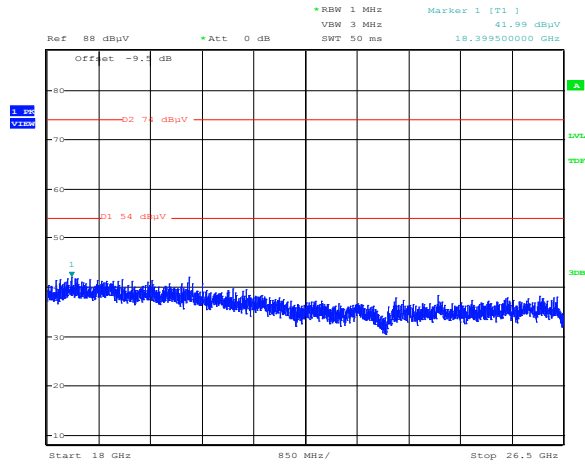

Figure 8.6-46: Radiated spurious emissions for BT, high channel, 18 to 26.5 GHz

8.6.5 Test data, continued

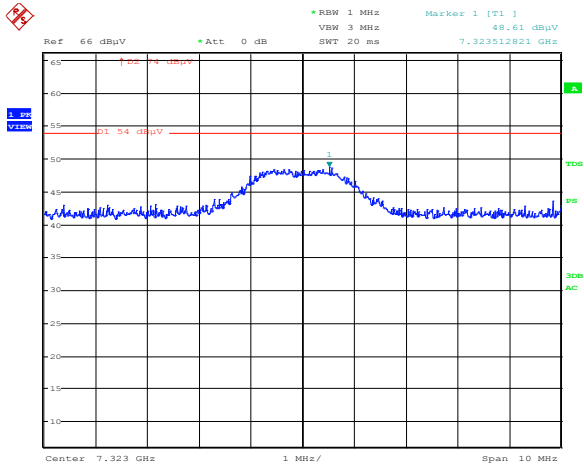

Figure 8.6-47: Radiated spurious emissions 2nd harmonic peak level for BT, low channel

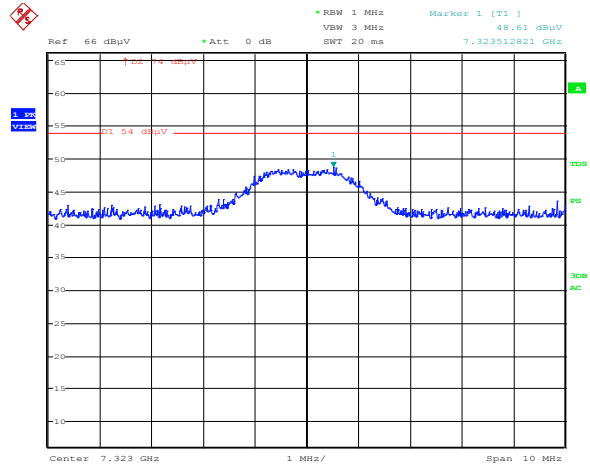

Figure 8.6-48: Radiated spurious emissions 2nd harmonic peak level for BT, mid channel

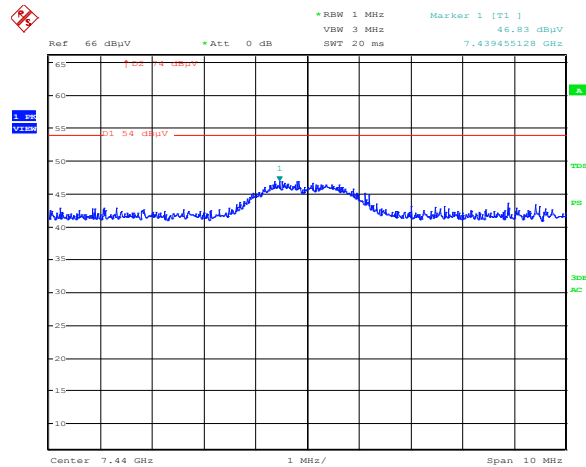
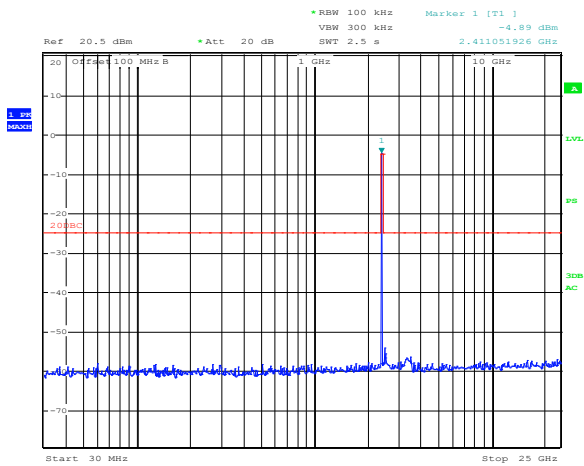

Figure 8.6-49: Radiated spurious emissions 2nd harmonic peak level for BT, high channel

8.6.5 Test data, continued



Date: 22.JUL.2016 16:42:24

Figure 8.6-50: Conducted spurious emissions for BLE, low channel

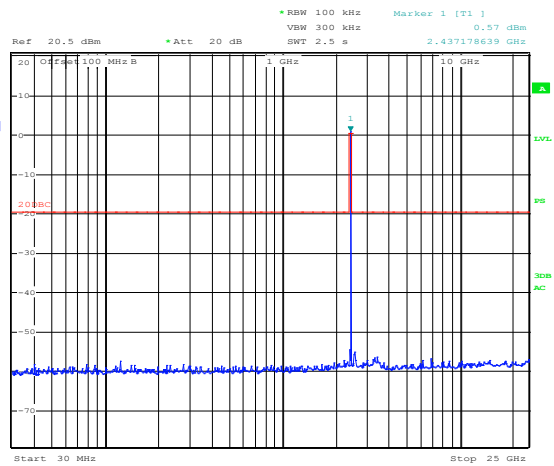

Date: 22.JUL.2016 16:44:55

Figure 8.6-51: Conducted spurious emissions for BLE, mid channel

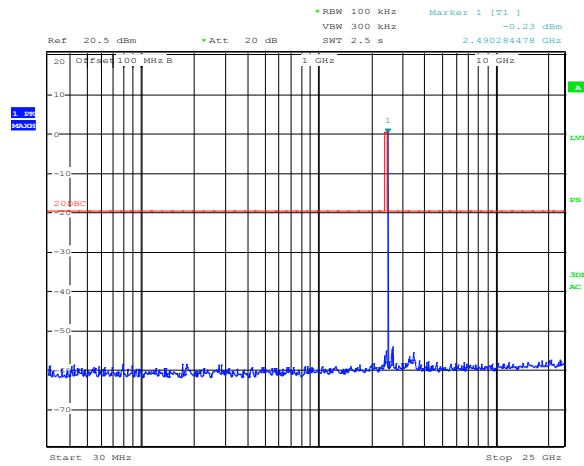

Date: 22.JUL.2016 16:45:50

Figure 8.6-52: Conducted spurious emissions for BLE, high channel

8.6.5 Test data, continued

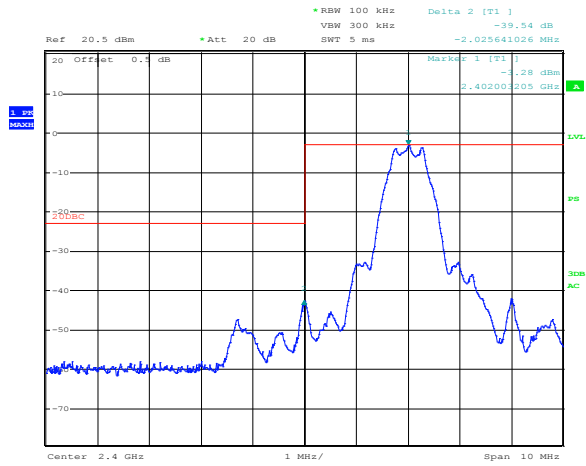

Date: 22.JUL.2016 16:47:22

Figure 8.6-53: Conducted spurious emissions Lower band for BLE, low channel

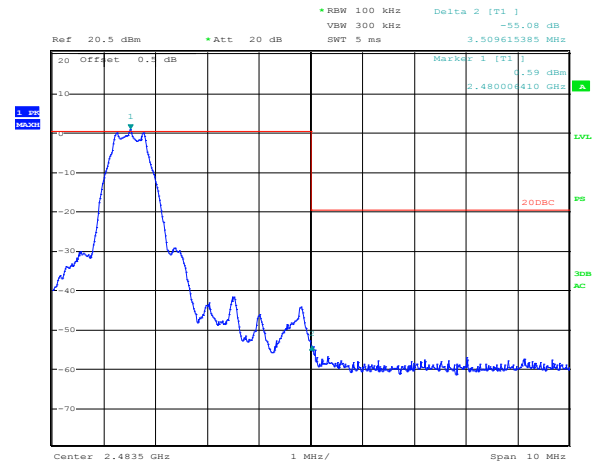

Date: 22.JUL.2016 16:46:37

Figure 8.6-54: Conducted spurious emissions upper band edge for BLE, high channel

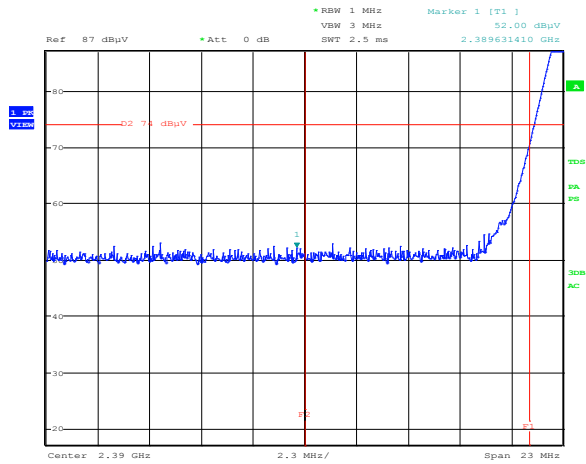

Figure 8.6-55: Radiated spurious emissions Lower band edge emission for BLE, low channel. $F_2 = 2.39$ GHz (end of restricted band), $F_1 = 2.4$ GHz

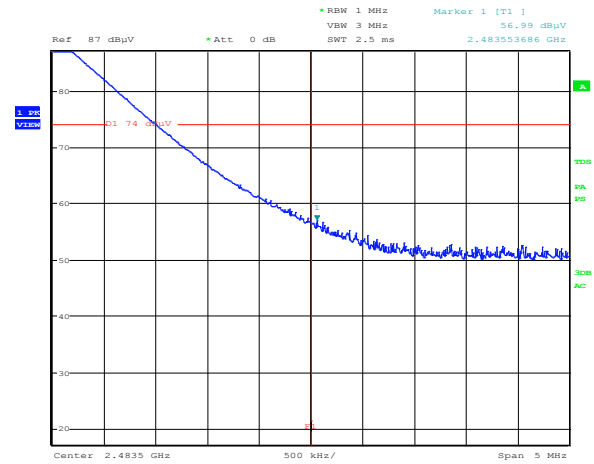

Figure 8.6-56: Radiated spurious emissions Upper band edge emission for BLE, High channel. $F_1 = 2.4835$ GHz (beginning of restricted band)

8.6.5 Test data, continued

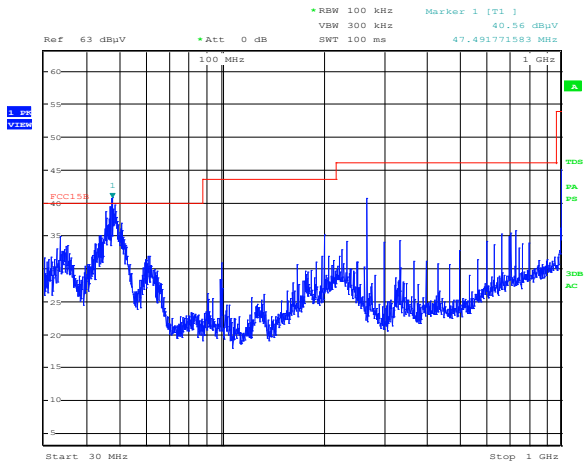

Figure 8.6-57: Radiated spurious emissions for BLE, low channel, 30 to 1000 MHz

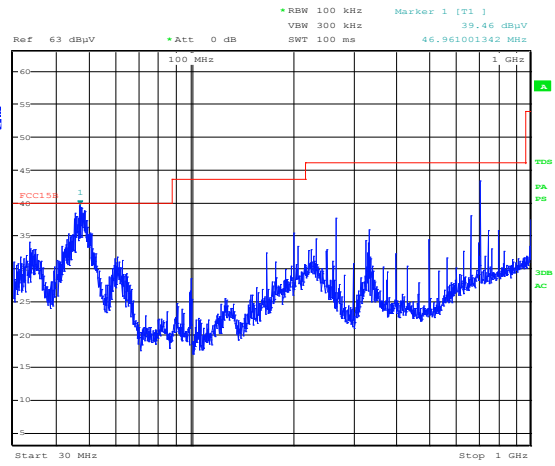

Figure 8.6-58: Radiated spurious emissions for BLE, mid channel, 30 to 1000 MHz

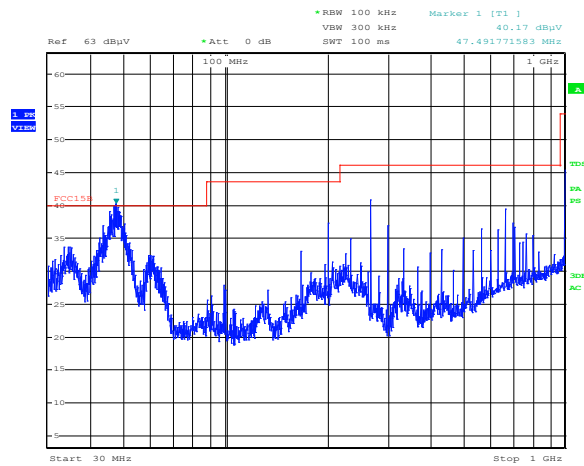

Figure 8.6-59: Radiated spurious emissions for BLE, high channel, 30 to 1000 MHz

8.6.5 Test data, continued

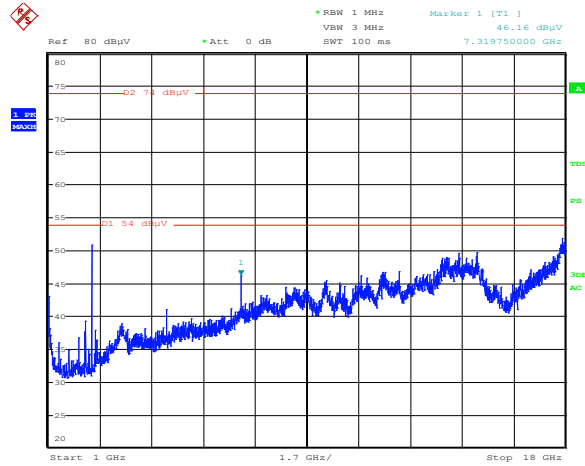
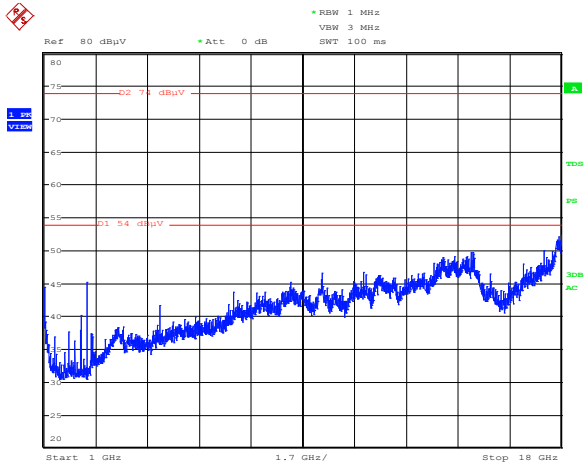

Figure 8.6-60: Radiated spurious emissions for BLE, low channel, 1 to 18 GHz

Figure 8.6-61: Radiated spurious emissions for BLE, mid channel, 1 to 18 GHz

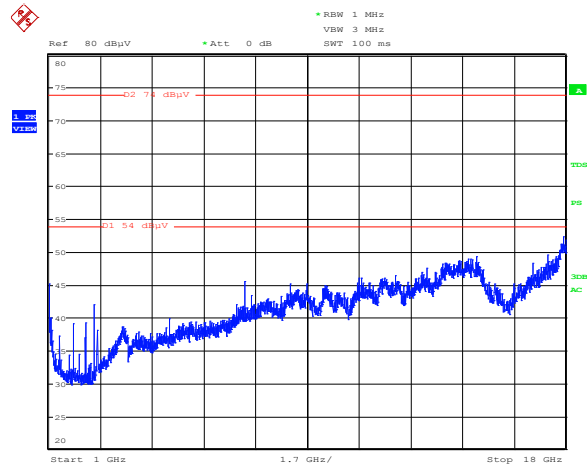

Figure 8.6-62: Radiated spurious emissions for BLE, high channel, 1 to 18 GHz

8.6.5 Test data, continued

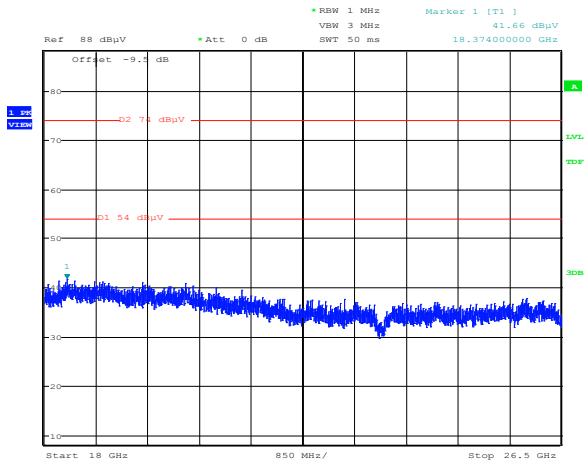

Figure 8.6-63: Radiated spurious emissions for BLE, low channel, 18 to 26.5 GHz

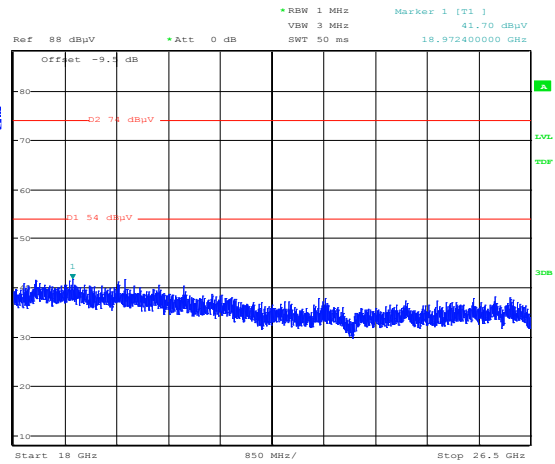

Figure 8.6-64: Radiated spurious emissions for BLE, mid channel, 18 to 26.5 GHz

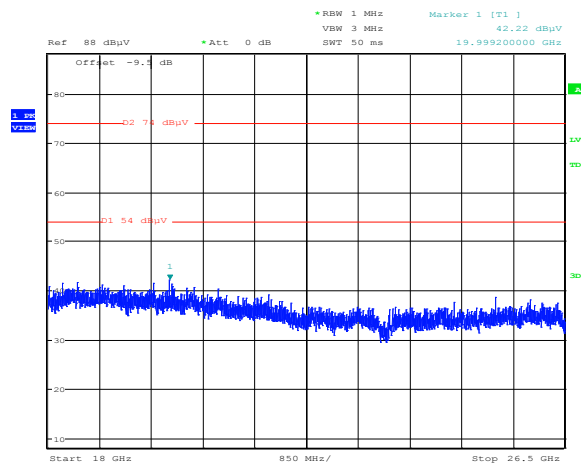

Figure 8.6-65: Radiated spurious emissions for BLE, high channel, 18 to 26.5 GHz

8.6.5 Test data, continued

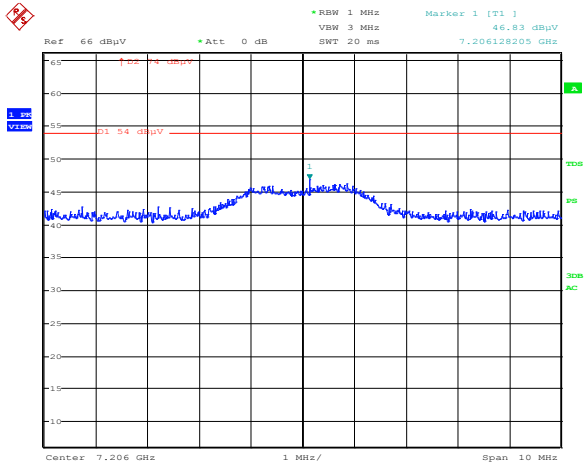

Figure 8.6-66: 2nd harmonic peak level for BLE, low channel

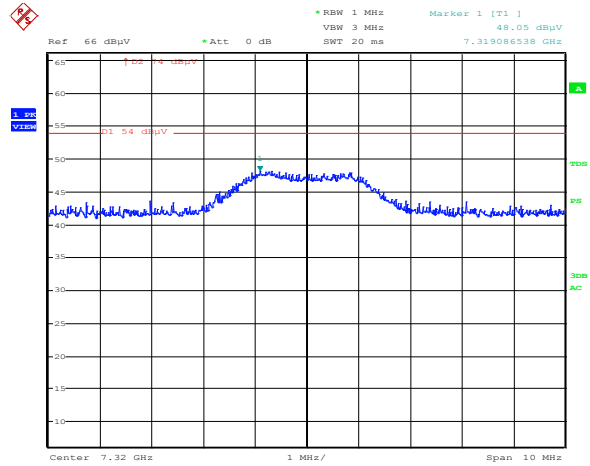

Figure 8.6-67: 2nd harmonic peak level for BLE, mid channel

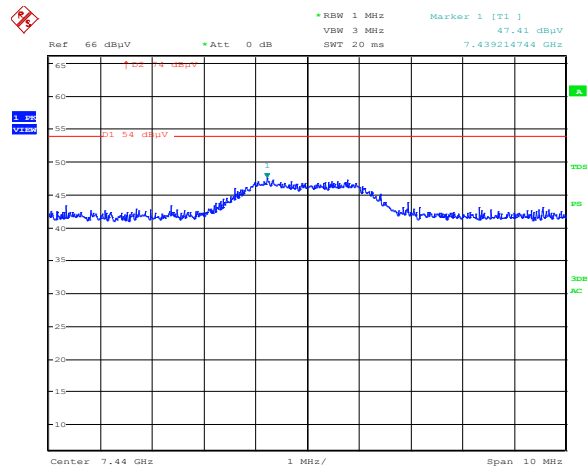

Figure 8.6-68: 2nd harmonic peak level for BLE, high channel

8.6.6 Setup photos



Figure 8.6-69: Radiated spurious (out-of-band) emissions setup photo – 30 to 1000 MHz



Figure 8.6-70: Radiated spurious (out-of-band) emissions setup photo – 30 to 1000 MHz

8.6.6 Setup photos, continued



Figure 8.6-71: Radiated spurious (out-of-band) emissions setup photo – above 1 GHz

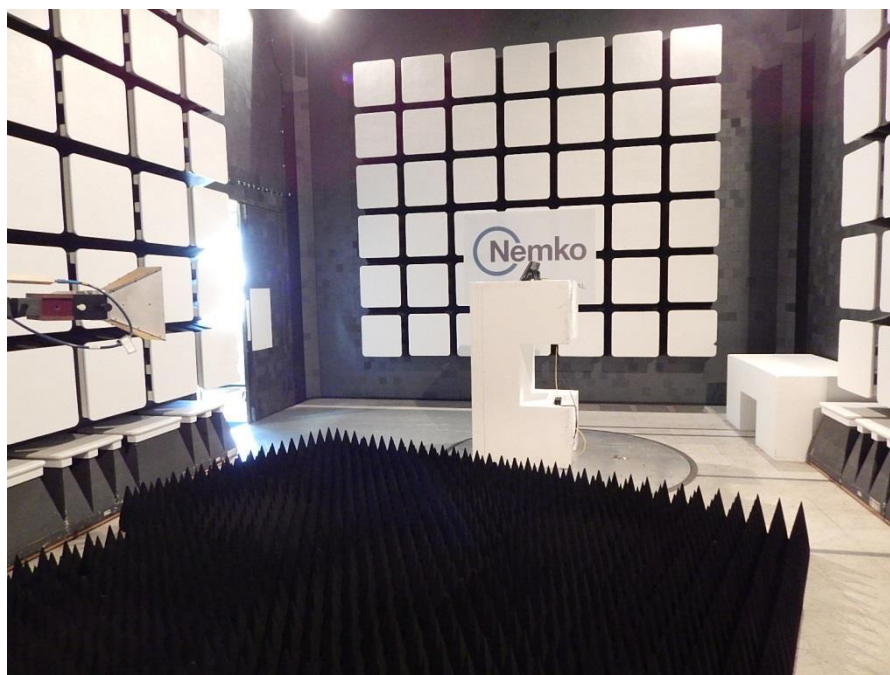

Figure 8.6-72: Radiated spurious (out-of-band) emissions setup photo – above 1 GHz



8.7 FCC 15.247(e) and RSS-247 5.2(2) Power spectral density for digitally modulated devices (DTS-BLE)

8.7.1 Definitions and limits

FCC §15.247 (e):

For digitally modulated systems, the power spectral density conducted from the intentional radiator to the antenna shall not be greater than 8 dBm in any 3 kHz band during any time interval of continuous transmission. This power spectral density shall be determined in accordance with the provisions of paragraph (b) of this section. The same method of determining the conducted output power shall be used to determine the power spectral density.

RSS-247, Clause 5.2 (2):

The transmitter power spectral density conducted from the transmitter to the antenna shall not be greater than 8 dBm in any 3 kHz band during any time interval of continuous transmission. This power spectral density shall be determined in accordance with the provisions of Section 5.4(4), (i.e. the power spectral density shall be determined using the same method as is used to determine the conducted output power).

8.7.2 Test summary

Verdict	Pass				
Test date	July 22, 2016	Test engineer	Andrey Adelberg		
Temperature	21.7 °C	Relative humidity	49 %	Air pressure	1010 mbar

8.7.3 Notes

- EUT was set to transmit in **BLE mode**.
- Measurements were performed as per 558074 D01 DTS Meas Guidance v03r05. (The test was performed using method described in section 10.2 Method PKPSD (peak PSD).

8.7.4 Setup details

Spectrum analyser settings:

Resolution bandwidth:	3 kHz
Video bandwidth:	10 kHz
Frequency span:	2 MHz
Detector mode:	Peak
Trace mode:	Max Hold

Section 8

Testing data

Test name

FCC Clause 15.247(e) and RSS-247 5.2(2) Power spectral density for digitally modulated devices (DTS-BLE)

Specification

FCC Part 15 Subpart C and RSS-247, Issue 1



8.7.5 Test data

Table 8.7-1: PSD measurements results for BLE

Frequency, MHz	PSD, dBm/3 kHz	PSD limit, dBm/3 kHz	Margin, dB
2402	-18.57	8.00	26.57
2442	-14.03	8.00	22.03
2480	-14.71	8.00	22.71

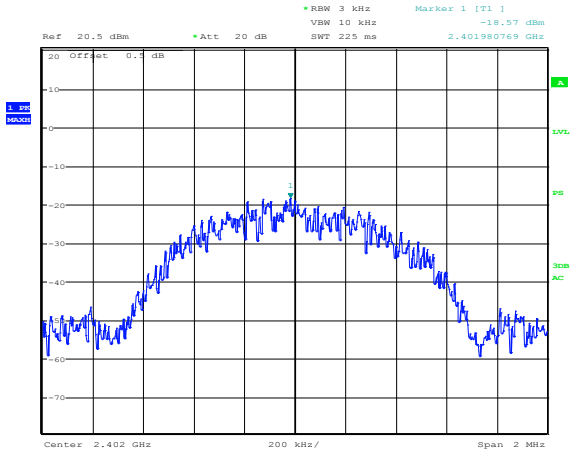

Date: 22.JUL.2016 16:48:38

Figure 8.7-1: PSD sample plot on low channel

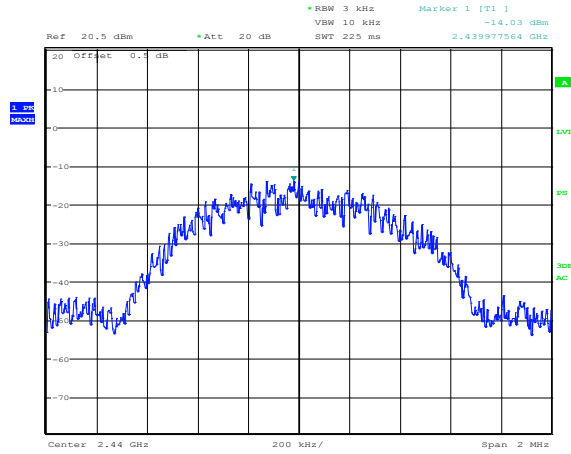

Date: 22.JUL.2016 16:49:32

Figure 8.7-2: PSD sample plot on mid channel

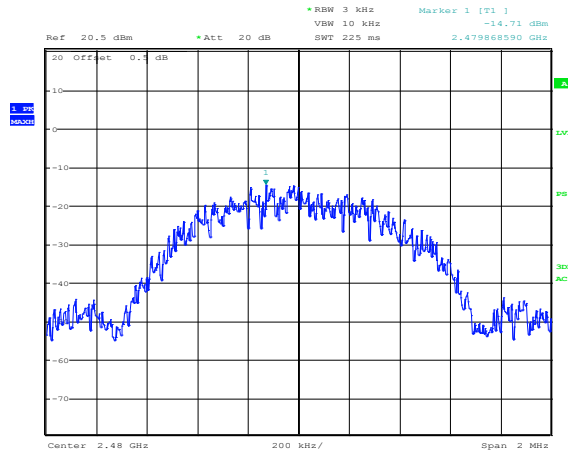

Date: 22.JUL.2016 16:50:21

Figure 8.7-3: PSD sample plot on high channel

Section 9. Block diagrams of test set-ups

9.1 Radiated emissions set-up for frequencies below 1 GHz

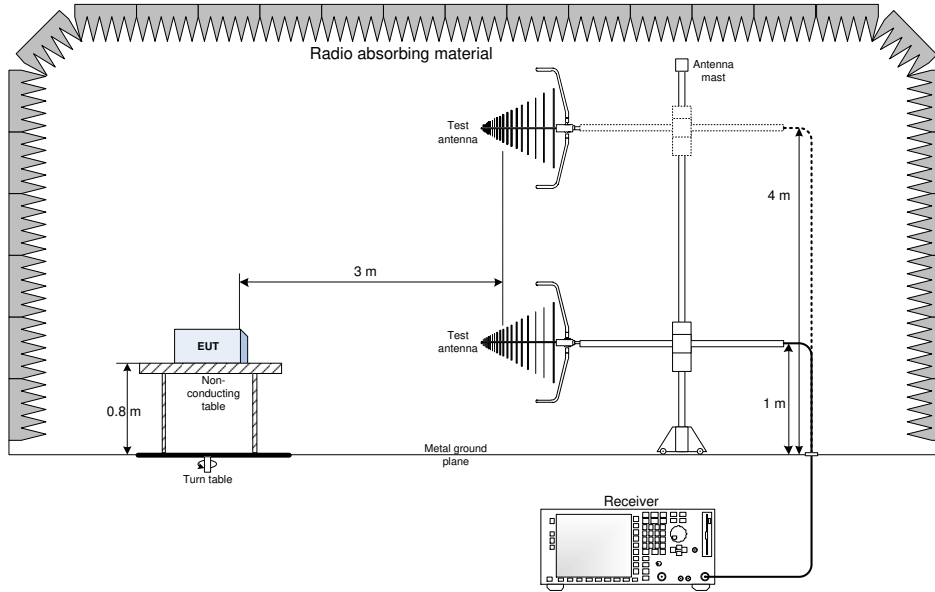

9.2 Radiated emissions set-up for frequencies above 1 GHz

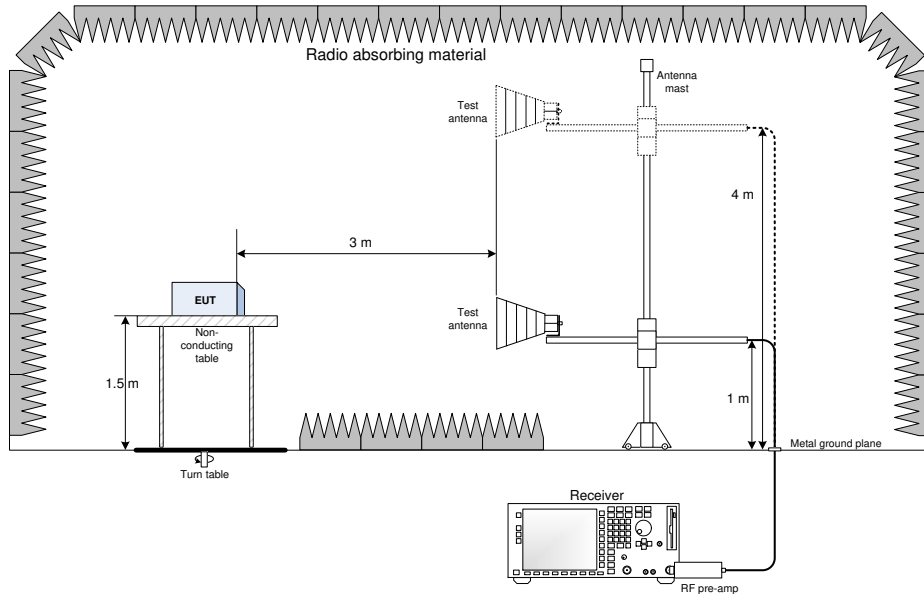

9.3 Conducted emissions set-up

