REPORT ON

The Specific Absorption Rate Assessment of the Intermec
700C Mobile Computer

Report Number: WS613256 – 001 Issue 2.00

December 2004

REPORT ON: The Specific Absorption Rate Assessment of the Intermec 700C Mobile Computer

Report No: WS613256 – 001 Issue 2.00

FCC ID: EHASMC46
IC: 1223A-SMC46

PREPARED FOR: Intermec Technologies
550 Second Street. SE
CEDAR RAPIDS
IA 52401-2023
USA

ATTESTATION: The wireless portable device described within this report has been shown to be capable of compliance for localised specific absorption rate (SAR) for General Population/Uncontrolled Exposure Limits as defined in the FCC standard Supplement C (Edition 01-01) to OET Bulletin 65 (Edition 97-01) and RSS-102 Issue 1 (Provisional) September 25, 1999 of 1.6 W/kg.

The measurements shown in this report were made in accordance with the procedures specified in Supplement C (Edition 01-01) to OET Bulletin 65 (Edition 97-01), RSS-102 Issue 1 (Provisional) September 25 and IEEE 1528-2003

All reported testing was carried out on a sample of equipment to demonstrate compliance with the above standards. The sample tested was found to comply with the requirements in the applied rules.



K. Hall
SAR Test Engineer

APPROVED BY:

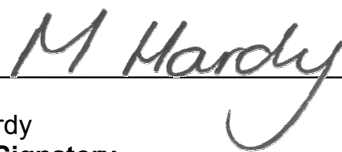

M J Hardy
UKAS Signatory

DATED: 17th December 2004

DISTRIBUTION: Intermec Technologies Corporation
BABT

Copy No: 1
Copy No.: 2
Copy No.: 1

Note: The test results reported herein relate only to the item tested as identified above and on the Status Page.

Report No. WS613256-001 has been up-issued to issue 2 to include additional information to clarify areas of the testing performed.



CONTENTS

EXECUTIVE SUMMARY	3
1.1 Status	4
1.2 Summary.....	5
1.3 Test Result Summary	7
TEST DETAILS	11
2.1 Test Equipment.....	12
2.2 Test Software	12
2.3 Dielectric Properties of Simulant Liquids	13
2.4 Test Conditions	14
2.5 Measurement Uncertainty.....	15
2.6 SAR Measuring System.....	16
Probe and Amplifier Specification	
Probe Calibration	
SAR Measurement Procedure	
2.7 OET65(c) Flat Phantom Test Position(s).....	34
2.8 SAR Distributions (Area Scans – 2D)	40
2.9 Test Positional Photographs.....	72
2.10 Record Photographs	75
2.11 Copyright Statement	82



EXECUTIVE SUMMARY

The Specific Absorption Rate Assessment of Intermecc
700C Mobile Computer

PROJECT MANAGER: M. Foley



1.1 STATUS

MANUFACTURING DESCRIPTION	Mobile Computer
STATUS OF TEST	Specific Absorption Rate Testing
APPLICANT	Intermec Technologies Inc
MANUFACTURER	Intermec Technologies Inc
TYPE NUMBER	700C
PART NUMBER	700CXL Proto-c
SERIAL NUMBER	18190400038
HARDWARE VERSION	761A91G5E700N000 (Agency-C-05)
ANTENNA TYPE	805-624-001
GPRS/GSM TRI-BAND RADIO TYPE	Siemens AG MC46 11/1
GPRS MULTISLOT CLASS	Multislot Class 10 (Rx 4; Tx 2; Sum 5)
IMEI NUMBER	351961000794972
GSM/GPRS POWER CLASS	850MHz Class 4; 1900MHz Class 1

TEST SPECIFICATIONS:

US Federal Government, Code of Federal Regulations, Title 47 Telecommunication, Chapter I
Federal Communications Commission, part 2, section 1093.

Federal Communications Commission (FCC) OET Bulletin 65c, Edition 01-01, Evaluating
Compliance with FCC Guidelines for Human Exposure to Radiofrequency Electromagnetic
Fields – Additional Information for Evaluating Compliance of Mobile and Portable Devices with
FCC Limits for Human Exposure to Radiofrequency Emissions

RSS-102 Issue 1 (Provisional) September 25, 1999: Evaluation Procedure for Mobile and
Portable Radio Transmitters with respect to Health Canada's Safety Code 6 for Exposure of
Humans to radio Frequency Fields.

REFERENCES:

IEEE 1528 – 2003: Recommended Practice for Determining the Peak Spatial-Average Specific
Absorption Rate (SAR) in the Human Body Due to Wireless Communications Devices:
Experimental Techniques

BABT REGISTRATION NUMBER: WS613256

RECEIPT OF TEST SAMPLES: 18th November 2004
START OF TEST: 19th November 200
FINISH OF TEST: 25th November 2004



1.2 SUMMARY

The unit supplied for testing is an Intermec 700C Mobile Computer, which offers Tri-Band GSM/GPRS 850/1800/1900 connectivity. The following accessories were supplied for assessment with the device, these were: -

- Belt Clip – Manufactured by The Clip Company (Part/No 805-612-001)
- 700C Holster#1 – Manufactured by Koszegi Industries Inc (Part/No 815-047-001)
- 700C Holster #2– Manufactured by Koszegi Industries Inc (Part/No 815-047-002)
- 700C Earpiece– Supplied by Intermec Technologies Inc (Part/No 10058030000-01)

For Head SAR assessment, testing was performed with the device in GSM mode only using a Specific Anthropomorphic Mannequin (SAM) phantom, as specified in IEEE 1528-2003. The phantom was filled with different simulant liquid appropriate to each frequency band. The dielectric properties were measured and found to be in accordance with the requirements for the dielectric properties specified in IEEE 1528-2003. The Intermec 700C Mobile Computer had a fixed external antenna so that the requirement for testing with antenna extended and retracted was not applicable

SAR testing was performed at both the left and right ear of the phantom at both handset positions stated in the above specification. Testing was performed at the middle frequency of each band and at the top and the bottom frequencies for the position giving maximum SAR. The sequence used accorded with the block diagram of tests given in EN 50361. Testing was performed at the maximum power for both the GSM850 and GSM1900 bands testing. This was achieved using a GSM test set, which controlled the handset at power level 5 and power level 0 respectively.

It is acknowledged that the device can be positioned in both Holsters in various positions. Therefore prior to Body SAR assessment, the device was placed into the appropriate test position and worst case antenna positions, (judged by separation distance) were established to reduce the number of SAR scans.

Scans were performed at each position pertaining to the minimum separation distance to ascertain the maximum SAR for the device. The device was placed into the appropriate test mode and an area scan was performed on each face of the device to ascertain the location of the transmitter to enable the SAR testing to be performed on the appropriate face. This was performed for each Radio Module fitted. This was carried out with and without the Headset in position for the body assessment, this showed that there was no difference in SAR values and therefore nearly all testing was carried out without the headset being used. A headset was used, (see figures 73 & 74), and was found to be negligible.

For Body SAR assessment, the device was tested for typical body-worn operation. Flat Phantom dimensions 220mmx200mmx150mm and with a sidewall thickness of 2.0mm. The phantom was filled to a depth of 150mm with the appropriate Body simulant liquid. The dielectric properties were in accordance with the requirements for the dielectric properties specified in Supplement C (Edition 01-01) to OET Bulletin 65 (Edition 97-01).

For Body SAR assessment the device was placed into a GPRS Multislot Class 10 configuration, with 2 timeslots transmitting at maximum power for both the GSM850 and GSM1900. This was achieved using a Universal Radio Communication Tester (CMU200), which controlled the number of transmit slots and the handset power at level 5 (GSM850), and power level 0 (GSM1900) respectively. The 700C Mobile Computer was first placed into Holster #1 with the rear of the Holster placed to the 'side to phantom' (body). The device was then positioned in its intended user position whilst SAR assessment was carried out in the bottom, middle and top channel for each band assessed. This approach identified the channel giving the maximum SAR for the device. The Device was then positioned in the one alternative position which gave the minimum distance relating to antenna phantom distance. A single SAR assessment was carried in this position for each band at channel 189 (GSM850) and channel 512 (GSM1900).



1.3 SUMMARY– Continued

The 700C Mobile Computer was then placed into a Holster the device was first positioned in its intended user position whilst a single SAR assessment was carried in this position. The Device was then positioned in the one alternative position which gave the minimum distance relating to antenna phantom distance and another single SAR assessment was carried in this position. The following channels were adjudged to give the maximum SAR for the device, Channel 189 (GSM850) and channel 512 (GSM1900).

The device was configured with a belt – clip attachment. The device was then placed in its intended user position whilst a single SAR assessment was carried out in this position for each band assessed. The following channels were adjudged to give the maximum SAR for the device, Channel 189 (GSM850) and channel 512 (GSM1900).

The belt clip of the Mobile Computer Holster contains a metal spring enclosed within a plastic housing, with nominal dimensions: Overall length 80mm (formed into a semi-closed U shape); width 25mm and thickness 0.5mm. For each band channel 189 (GSM850) and channel 512 (GSM1900) were adjudged to give the maximum SAR for the device.

Included in this report are descriptions of the test method; the equipment used and an analysis of the test uncertainties applicable and diagrams indicating the locations of maximum SAR for each test position along with photographs indicating the positioning of the handset against either the right or left ear, and/or distance and from the body as appropriate,

The maximum 10g volume averaged SAR level measured for all the tests performed did not exceed the 2 W/kg level defined for limiting the exposure of the general population to time-varying electric and magnetic fields by ICNIRP (1998), which is the relevant Standard for testing according to the CENELEC EN50361 test method.

The following scans show a limited scan area, these are Figures 33/34/35/36/39/40/41/42/43. This indicates a more defined area showing the area of RF concentration at extreme regions of a normal scan.

The maximum 1g volume averaged SAR level measured for all the tests performed did not exceed the limits for General Population/Uncontrolled Exposure (W/kg) Partial Body of 1.6 W/kg. Level defined in Supplement C (Edition 01-01) to OET Bulletin 65 (97-01).

WORST CASE SAR VALUE / POSITION / MODE

POSITION:	The 700C in Holster #1 LCD panel facing to phantom*.
ANTENNA DISTANCE:	4.0cm from terminal case to phantom
MODE:	GPRS 850MHz.
SAR Value:	0.544 / 0.384 W/kg (1g Limit & 10g W/kg).

* Note: Not designated as normal use position. Information provide as device can stored in various positions with the holster.

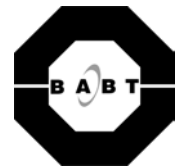

1.4 TEST RESULT SUMMARY

SYSTEM PERFORMANCE / VALIDATION CHECK RESULTS

Prior to formal testing being performed a System Check was performed in accordance with IEEE 1528-2003 and results were compared against published data in standard IEEE 1528-2003. The following results were obtained: -

Date	Dipole Used	Frequency (MHz)	Max 1g SAR (W/kg)*	Percentage Drift on 1g Reference	Max 10g SAR (W/kg)*	Percentage Drift on 10g Reference
15/11/04	900	907.5	10.99*	1.77%	7.0*	1.43%
25/11/04	900	907.5	10.83*	0.26%	6.93*	0.45%
19/11/04	1900	1883.6	39.29*	-1.04%	20.02*	-2.32%

*Normalised to 1W

MAXIMUM SAR VALUES

The following is a summary of the maximum SAR values found during the Head SAR assessment.

GSM 850 HEAD SPECIFIC ABSORPTION RATE (MAXIMUM SAR) 1g & 10g RESULTS FOR THE INTERMEC TECHNOLOGIES 700C MOBILE COMPUTER

Position		Channel Number	Frequency (MHz)	Max Spot SAR (W/kg)	Max 1g SAR (W/kg)	Max 10g SAR (W/kg)	SAR Drift dB	Area scan (Figure number)
Left or Right Hand Ear	Mobile Position							
LH	Cheek	189	836.4	0.19	0.166	0.123	0.05	Figure 31
LH	15°	189	836.4	0.21	0.190	0.141	0.11	Figure 32
RH	Cheek	189	836.4	0.24	0.209	0.148	0.04	Figure 33
RH	15°	189	836.4	0.41	0.355	0.246	0.00	Figure 34
RH	15°	128	824.2	0.34	0.296	0.209	0.00	Figure 35
RH	15°	251	848.8	0.41	0.354	0.249	-0.09	Figure 36
Limit for General Population (Uncontrolled Exposure) 1.6 W/kg (1g) & 2.0 W/kg (10g)								

GSM1900 HEAD SPECIFIC ABSORPTION RATE (MAXIMUM SAR) 1g & 10g RESULTS FOR THE INTERMEC TECHNOLOGIES 700C MOBILE COMPUTER

Position		Channel Number	Frequency (MHz)	Max Spot SAR (W/kg)	Max 1g SAR (W/kg)	Max 10g SAR (W/kg)	SAR Drift dB	Area scan (Figure number)
Left or Right Hand Ear	Mobile Position							
LH	Cheek	661	1880.0	0.07	0.064	0.041	0.00	Figure 37
LH	15°	661	1880.0	0.09	0.082	0.052	0.07	Figure 38
RH	Cheek	661	1880.0	0.13	0.181	0.087	0.13	Figure 39
RH	15°	661	1880.0	0.21	0.209	0.133	0.00	Figure 40
RH	15°	512	1850.2	0.23	0.226	0.146	-0.11	Figure 41
RH	15°	810	1909.8	0.23	0.217	0.146	-0.03	Figure 42
Limit for General Population (Uncontrolled Exposure) 1.6 W/kg (1g) & 2.0 W/kg (10g)								



1.4 TEST RESULT SUMMARY

MAXIMUM SAR VALUES

The following is a summary of the maximum SAR values found during the Body SAR assessment.

GPRS1900 SPECIFIC ABSORPTION RATE (MAXIMUM SAR) 1g & 10g RESULTS FOR THE INTERMEC TECHNOLOGIES 700C MOBILE COMPUTER INSERTED INTO HOLSTER #1

Position	Channel Number	Frequency (MHz)	Max Spot SAR (W/kg)	Max 1g SAR (W/kg)	Max 10g SAR (W/kg)	SAR Drift dB	Area scan (Figure number)
*Rear to phantom	661	1880	0.35	0.295	0.184	-0.02	Figure 43
Front to Phantom	661	1880	0.38	0.325	0.207	-0.03	Figure 44
Front to Phantom	512	1850.2	0.46	0.393	0.250	-0.01	Figure 45
Front to Phantom	810	1909.8	0.40	0.348	0.220	0.04	Figure 46
Limit for General Population (Uncontrolled Exposure) 1.6 W/kg (1g) & 2.0 W/kg (10g)							

* Note: Not designated as normal use position, data provided as additional information

GPRS1900 SPECIFIC ABSORPTION RATE (MAXIMUM SAR) 1g & 10g RESULTS FOR THE INTERMEC TECHNOLOGIES 700C MOBILE COMPUTER INSERTED INTO HOLSTER #2

Position	Channel Number	Frequency (MHz)	Max Spot SAR (W/kg)	Max 1g SAR (W/kg)	Max 10g SAR (W/kg)	SAR Drift dB	Area scan (Figure number)
Front to Phantom	512	1850.2	0.17	0.146	0.096	-0.11	Figure 47
* Front to Phantom	512	1850.2	0.25	0.213	0.138	0.00	Figure 48
Side to Phantom	512	1850.2	0.23	0.195	0.127	-0.02	Figure 49
Side to Phantom	512	1850.2	0.2	0.177	0.115	0.11	Figure 50
Limit for General Population (Uncontrolled Exposure) 1.6 W/kg (1g) & 2.0 W/kg (10g)							

* Note: Not designated as normal use position, data provided as additional information



1.4 TEST RESULT SUMMARY

MAXIMUM SAR VALUES

The following is a summary of the maximum SAR values found during the Body SAR assessment.

GPRS850 SPECIFIC ABSORPTION RATE (MAXIMUM SAR) 1g & 10g RESULTS FOR THE INTERMEC TECHNOLOGIES 700C MOBILE COMPUTER INSERTED INTO HOLSTER #1

Position	Channel Number	Frequency (MHz)	Max Spot SAR (W/kg)	Max 1g SAR (W/kg)	Max 10g SAR (W/kg)	SAR Drift dB	Area scan (Figure number)
*Rear to Phantom	189	836.4	0.40	0.360	0.261	-0.12	Figure 51
Front to Phantom	189	836.4	0.60	0.544	0.384	-0.15	Figure 52
Front to Phantom	128	824.2	0.53	0.482	0.343	-0.10	Figure 53
Front to Phantom	251	848.8	0.59	0.526	0.373	-0.15	Figure 54
Limit for General Population (Uncontrolled Exposure) 1.6 W/kg (1g) & 2.0 W/kg (10g)							

* Note: Not designated as normal use position, data provided as additional information

GPRS850 SPECIFIC ABSORPTION RATE (MAXIMUM SAR) 1g & 10g RESULTS FOR THE INTERMEC TECHNOLOGIES 700C MOBILE COMPUTER INSERTED INTO HOLSTER #2

Position	Channel Number	Frequency (MHz)	Max Spot SAR (W/kg)	Max 1g SAR (W/kg)	Max 10g SAR (W/kg)	SAR Drift dB	Area scan (Figure number)
Front to Phantom	189	836.4	0.57	0.508	0.362	-0.04	Figure 55
*Front to Phantom	189	836.4	0.33	0.291	0.208	-0.05	Figure 56
*Front to Phantom (2 nd scan)	189	836.4	0.35	0.312	0.223	-0.01	Figure 57
* Front to Phantom	189	836.4	0.61	0.540	0.375	-0.04	Figure 58
*Side to Phantom	189	836.4	0.47	0.414	0.284	-0.11	Figure 59
* Side to Phantom	189	836.4	0.45	0.407	0.292	-0.08	Figure 60
Limit for General Population (Uncontrolled Exposure) 1.6 W/kg (1g) & 2.0 W/kg (10g)							

* Note: Not designated as normal use position, data provided as additional information

GPRS850 & GPRS1900 SPECIFIC ABSORPTION RATE (MAXIMUM SAR) 1g & 10g RESULTS FOR THE INTERMEC TECHNOLOGIES 700C MOBILE COMPUTER CONFIGURED WITH BELT CLIP.

Position	Channel Number	Frequency (MHz)	Max Spot SAR (W/kg)	Max 1g SAR (W/kg)	Max 10g SAR (W/kg)	SAR Drift dB	Area scan (Figure number)
Rear to Phantom	189	836.4	0.21	0.180	0.128	-0.19	Figure 61
Rear to Phantom	512	1850.2	0.16	0.142	0.093	-0.06	Figure 62
Limit for General Population (Uncontrolled Exposure) 1.6 W/kg (1g) & 2.0 W/kg (10g)							



OUTPUT POWER OF TEST DEVICE MEASUREMENT METHOD

For the Intermec Technologies 700C Mobile Computer.

The path loss was initially measured between the peak power sensor and EUT. This was done with a signal generator and a power meter. The CMU 200 was used to put the phone into a call for each desired band and channel. The path loss was entered into the peak power analyser as an offset and the peak power was measured.

The diagram below show the test set up used for the measurements.

Test Equipment

8990A Peak Power Analyser EMC 1670
 84812A Peak Power Sensor EMC 1662
 CMU 200
 1506A Combiner EMC 113
 Cable
 Cable
 Cable
 10dB Attenuator EMC1970

Calibration Date

24/08/05
 24/08/05
 23/01/05
 Traceability Unscheduled
 Traceability Unscheduled
 Traceability Unscheduled
 11/11/05

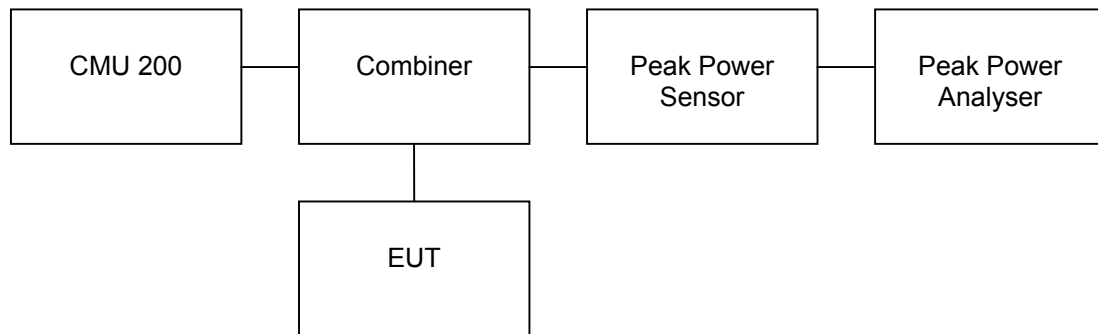

MAXIMUM POWER

Recorded from the Intermec Technologies 700C Mobile Computer

Radio Device	Frequency (MHz)	GSM (dBm)	GSM (mW)	GPRS (dBm)	GPRS (mW)
850MHz MC46	848.8	30.94	1241.65	30.86	1218.99
850MHz MC46	836.4	31.27	1339.68	31.1	1288.25
850MHz MC46	824.2	31.65	1462.18	31.54	1425.61
1900MHz MC46	1909.8	29.51	893.31	29.44	879.02
1900MHz MC46	1880.0	28.67	736.21	28.67	736.21
1900MHz MC46	1850.2	29.43	877.00	29.36	862.98



TEST DETAILS

The Specific Absorption Rate Assessment of the Intermec
700C Mobile Computer

TEST ENGINEER: K. HALL



The following test equipment was used at BABT:

2.1 TEST EQUIPMENT

INSTRUMENT DESCRIPTION	MANUFACTURER	MODEL TYPE	INVENTORY NO.	SERIAL NUMBER	CALIBRATION DATES	
					From	To
Bench-top Robot	Mitsubishi	RV-E2	4691	EA009006	N/A	N/A
900 MHz – Head Tissue Simulant	BABT	Head	N/A	Batch 7	06/11/04	30/11/04
900 MHz – Body Tissue Simulant	BABT	Body	N/A	1	06/11/04	30/11/04
900 MHz Calibration Dipole	BABT	IEEE 1528	A	N/A	15/11/04	16/11/04
900 MHz Calibration Dipole	BABT	IEEE 1528	A	N/A	25/11/04	26/11/04
1900 MHz – Head Tissue Simulant	BABT	Head	N/A	Batch 1	06/11/04	30/11/04
1900 MHz – Body Tissue Simulant	BABT	Body	N/A	1	06/11/04	30/11/04
1900 MHz Calibration Dipole	BABT	IEEE 1528	A	N/A	19/11/04	20/11/04
RF Amplifier	Vectawave	10M-2.5G	4697	N/A	N/A	N/A
Directional Coupler	Krytar	1850	4651	N/A	N/A	N/A
20dB Attenuator	Narda	766F-10	EMC 1791	1791	28/05/04	28/05/05
Power Meter	Rohde Schwarz	NRV	2472	860327/025	27/05/04	27/05/05
Hygrometer	Rotronic	I-1000	3230	N/A	04/10/03	18/10/05
Digital Thermometer	Digitron	T208	3178	N/A	16/09/03	13/10/05
Thermocouple	RS	219-4539	4859	N/A	16/06/03	13/10/05
SAR Probe	IndexSar	IXP-050	N/A	84	17/04/03	17/04/05
GSM test set	Rhode Schwarz	CMU 200	04858	-	30/06/04	30/06/05
WCDMA test set	Anritsu	MT8820A	N/A	-	19/07/04	19/07/05
Flat Phantom box 2mm side(200mm cube)	IndexSar	N/A	N/A	N/A	N/A	N/A

2.2 TEST SOFTWARE

The following software was used to control the BABT SARA2 System:

INSTRUMENT	VERSION NO.	DATE
SARA2 system	v2.3 VPM	29/02/2004
Mitsubishi robot controller firmware revision	RV-E2 Version C9a	-
IXA-10 Probe amplifier	Version 2.5	-



2.3 DIELECTRIC PROPERTIES OF SIMULANT LIQUIDS

The fluid properties of the simulant fluids used during routine SAR evaluation meet the dielectric properties required by EN 50361:2002

The fluids were calibrated in our laboratory and re-checked prior to any measurements being made against reference fluids stated in IEEE 1528-2003 of 0.9% NaCl (Salt Solution) at 23°C and also for Dimethylsulphoxide (DMS) at 21°C.

The fluids were made at BABT under controlled conditions from the following OET(65)c formulae and reference made to Standard IEEE 1528-2003. The composition of ingredients may have been modified accordingly to achieve the desired target tissue parameters required for routine SAR evaluation:

OET 65(c) Recipes

Ingredients (% by weight)	Frequency (MHz)									
	450		835		915		1900		2450	
Tissue Type	Head	Body	Head	Body	Head	Body	Head	Body	Head	Body
Water	38.56	51.16	41.45	52.4	41.05	56.0	54.9	40.4	62.7	73.2
Salt (NaCl)	3.95	1.49	1.45	1.4	1.35	0.76	0.18	0.5	0.5	0.04
Sugar	56.32	46.78	56.0	45.0	56.5	41.76	0.0	58.0	0.0	0.0
HEC	0.98	0.52	1.0	1.0	1.0	1.21	0.0	1.0	0.0	0.0
Bactericide	0.19	0.05	0.1	0.1	0.1	0.27	0.0	0.1	0.0	0.0
Triton X-100	0.0	0.0	0.0	0.0	0.0	0.0	0.0	0.0	36.8	0.0
DGBE	0.0	0.0	0.0	0.0	0.0	0.0	44.92	0.0	0.0	26.7
Dielectric Constant	43.42	58.0	42.54	56.1	42.0	56.8	39.9	54.0	39.8	52.5
Conductivity (S/m)	0.85	0.83	0.91	0.95	1.0	1.07	1.42	1.45	1.88	1.78

IEEE 1528 Recipes

Frequency (MHz)	300	450	835	900			1450	1800			1900	1950	2000	2100		2450			3000		
Recipe #	1	1	3	1	1	2	3	1	1	2	2	3	1	2	4	1	1	2	2	3	1
Ingredients (% by weight)																					
I,2-Propanediol						64.81															
Bactericide	0.19	0.19	0.5	0.1	0.1		0.5				0.5										0.5
Diacetin			48.9				49.2				49.43										49.75
DGBE								45.41	47	13.84	44.92		44.92	13.84	45	50	50	7.99	7.99		7.99
HEC	0.98	0.98		1	1																
NaCl	5.95	3.95	1.7	1.45	1.48	0.79	1.1	0.67	0.36	0.35	0.18	0.64	0.18	0.35					0.16	0.16	0.16
Sucrose	55.32	56.32		57	56.5																
Triton X-100										30.45					30.45					19.97	19.97
Water	37.56	38.56	48.9	40.45	40.92	34.4	49.2	53.82	52.64	55.36	54.9	49.43	54.9	55.36	55	50	50	71.88	71.88	49.75	71.88
Measured dielectric parameters																					
ϵ_r'	46	43.4	44.3	41.6	41.2	41.8	42.7	40.9	39.3	41	40.4	39.2	39.9	41	40.1	37	36.8	41.1	40.3	39.2	37.9
σ (S/m)	0.86	0.85	0.9	0.9	0.98	0.97	0.99	1.21	1.39	1.38	1.4	1.4	1.42	1.38	1.41	1.4	1.51	1.55	1.88	1.82	2.46
Temp. (°C)	22	22	20	22	22	22	20	22	22	21	22	20	21	21	20	22	22	20	20	20	20
Target dielectric parameters (Table 5-1)																					
ϵ_r'	45.3	43.5	41.5	41.5			40.5	40						39.8			39.2	38.5			
σ (S/m)	0.87	0.87	0.9	0.97			1.2	1.4						1.49			1.8	2.4			



2.3 DIELECTRIC PROPERTIES OF SIMULANT LIQUIDS

The dielectric properties of the tissue simulant liquids used for the SAR testing at BABT are as follows:-

FLUID TYPE AND FREQUENCY	RELATIVE PERMITTIVITY ϵ_r (ϵ') TARGET	RELATIVE PERMITTIVITY ϵ_r (ϵ') MEASURED	CONDUCTIVITY σ TARGET	CONDUCTIVITY σ MEASURED
Head 900MHz	41.5	41.26	0.97 S/m	0.979
Head 835MHz	41.5	42.60	0.90 S/m	0.913
Body 835MHz	55.2	58.12	0.97 S/m	0.991
Head 1900MHz	40.0	39.76	1.40 S/m	1.418
Body 1900MHz	53.3	51.44	1.52 S/m	1.566

Fluid Mass Density, $\rho = 1000 \text{ kg/m}^3$

2.4 TEST CONDITIONS

TEST LABORATORY CONDITIONS

Ambient Temperature: Within +15°C to +35°C at 20% RH to 75% RH.
 The actual Temperature during the testing ranged from 23.2°C to 25.5°C.
 The actual Humidity during the testing ranged from 22.4% to 42.9% RH.

TEST FLUID TEMPERATURE RANGE

TISSUE SIMULATING LIQUID TEMPERATURE: +20°C TO +25°C.				
FREQUENCY	850 MHz	850 MHz	1900 MHz	1900 MHz
BODY / HEAD FLUID	HEAD	BODY	HEAD	BODY
MIN TEMPERATURE	23.5	22.5	22.5	23.2
MAX TEMPERATURE	24.1	25.0	23.7	23.6

SAR DRIFT

SAR Drift during scans. The maximum SAR Drift, drift due to the mobile phone electronics, was recorded as 4.23% (-0.190) for all of the testing.



2.5 MEASUREMENT UNCERTAINTY

ERROR SOURCES	EN 50361 Description (Subclause)	Uncertainty (%)	Probability Distribution	Divisor	ci	ci^2	Standard Uncertainty (%)	Stand Uncert^2	(Stand Uncert^2) X (ci^2)
Measurement Equipment									
Calibration	7.2.1.1	10	Normal	2.00	1	1	5.00	25.00	25.00
Isotropy	7.2.1.2	10.6	Rectangular	1.73	1	1	6.12	37.45	37.45
Linearity	7.2.1.3	2.92	Rectangular	1.73	1	1	1.69	2.84	2.84
Probe Stability	-	2.46	Rectangular	1.73	1	1	1.42	2.02	2.02
Detection limits	7.2.1.4	0	Rectangular	1.73	1	1	0.00	0.00	0.00
Boundary effect	7.2.1.5	1.7	Rectangular	1.73	1	1	0.98	0.96	0.96
Measurement device	7.2.1.6	0	Normal	1.00	1	1	0.00	0.00	0.00
Response time	7.2.1.7	0	Normal	1.00	1	1	0.00	0.00	0.00
Noise	7.2.1.8	0	Normal	1.00	1	1	0.00	0.00	0.00
Integration time	7.2.1.9	2.3	Normal	1.00	1	1	2.30	5.29	5.29
Mechanical constraints									
Scanning system	7.2.2.1	0.57	Rectangular	1.73	1	1	0.33	0.11	0.11
Phantom shell	7.2.2.2	1.43	Rectangular	1.73	1	1	0.83	0.68	0.68
Matching between probe and phantom	7.2.2.3	2.86	Rectangular	1.73	1	1	1.65	2.73	2.73
Positioning of the phone 'Y' Coordinate	7.2.2.4	1.5	Normal	1.00	1	1	1.50	2.25	2.25
Positioning of the phone 'Z' Coordinate	7.2.2.4	1.73	Normal	1.00	1	1	1.73	2.99	2.99
Physical Parameters									
Liquid conductivity (deviation from target)	7.2.3.2	5	Rectangular	1.73	0.5	0.25	2.89	8.33	2.08
Liquid conductivity (measurement error)	7.2.3.2	15.3	Rectangular	1.73	0.5	0.25	8.33	78.03	19.51
Liquid permittivity (deviation from target)	7.2.3.3	5	Rectangular	1.73	0.5	0.25	2.89	8.33	2.08
Liquid permittivity (measurement error)	7.2.3.3	5	Rectangular	1.73	0.5	0.25	2.89	8.33	2.08
Drifts in output power of the phone, probe, temperature and humidity	7.2.3.4	5	Rectangular	1.73	1	1	2.89	8.33	2.08
Perturbation by the environment	7.2.3.5	3	Rectangular	1.73	1	1	1.73	3.00	3.00
Post-Processing									
SAR interpolation and extrapolation	7.2.4.1	2.4	Rectangular	1.73	1	1	1.39	1.92	1.92
Maximum SAR evaluation	7.2.4.2	2.4	Rectangular	1.73	1	1	1.39	1.92	1.92
Combined standard uncertainty	11.10						Total		123.26
Expanded uncertainty = 22.20 % (Using a Coverage Factor of K=2) (confidence interval of 95 %)									



2.6 SAR MEASUREMENT SYSTEM

ROBOT SYSTEM SPECIFICATION

The SAR measurement system being used is the IndexSar SARA2 system, which consists of a Mitsubishi RV-E2 6-axis robot arm and controller, IndexSar probe and amplifier and SAM phantom Head Shape. The robot is used to articulate the probe to programmed positions inside the phantom head to obtain the SAR readings from the DUT.

The system is controlled remotely from a PC, which contains the software to control the robot and data acquisition equipment. The software also displays the data obtained from test scans.

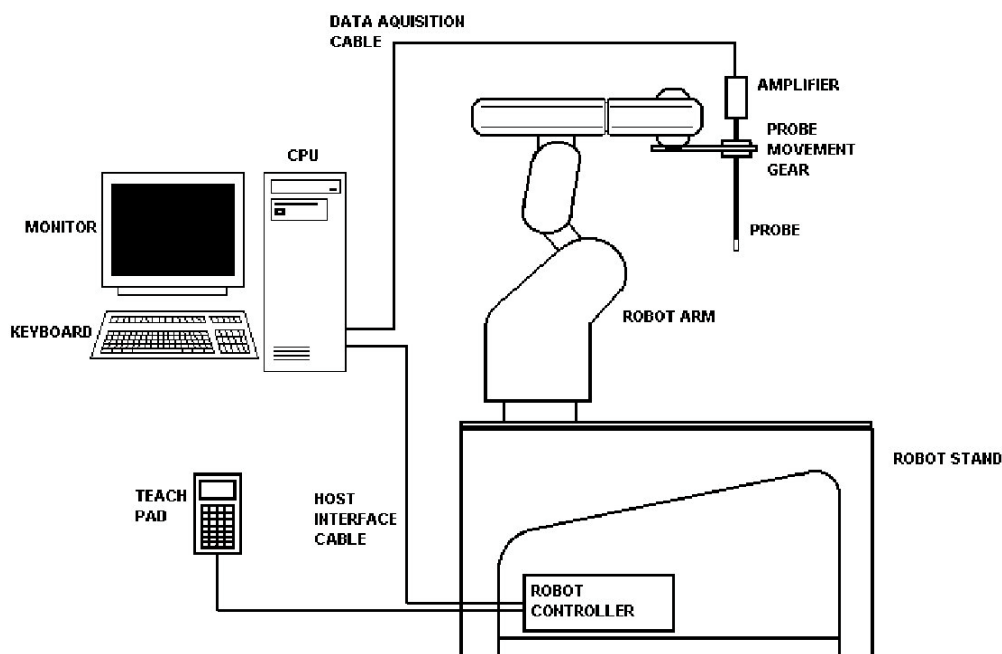

Figure 1: Schematic diagram of the SAR measurement system

The position and digitised shape of the phantom heads are made available to the software for accurate positioning of the probe and reduction of set-up time.

The SAM phantom heads are individually digitised using a Mitutoyo CMM machine to a precision of 0.001mm. The data is then converted into a shape format for the software, providing an accurate description of the phantom shell.

In operation, the system first does an area (2D) scan at a fixed depth within the liquid from the inside wall of the phantom. When the maximum SAR point has been found, the system will then carry out a 3D scan centred at that point to determine volume averaged SAR level.



2.6 SAR MEASUREMENT SYSTEM

PROBE AND AMPLIFIER SPECIFICATION

IXP-050 IndexSar isotropic immersible SAR probe

The probes are constructed using three orthogonal dipole sensors arranged on an interlocking, triangular prism core. The probes have built-in shielding against static charges and are contained within a PEEK cylindrical enclosure material at the tip. Probe calibration is described in the following section.

IXP-039 Amplifier

The amplifier unit has a multi-pole connector to connect to the probe and a multiplexer selects between the 3-channel single-ended inputs. A 16-bit AtoD converter with programmable gain is used along with an on-board micro-controller with non-volatile firmware. Battery life is around 150 hours and data are transferred to the PC via 3m of duplex optical fibre and a self-powered RS232 to optical converter.

Phantoms

The Specific Anthropomorphic Mannequin (SAM) Upright Phantom is fabricated using moulds generated from the CAD files as specified by CENELEC EN50361. It is mounted via a rotation base to a supporting table, which also holds the robotic positioner. The phantom and robot alignment is assured by both mechanical and laser registration systems.



2.6 SAR MEASUREMENT SYSTEM

PROBE CALIBRATION PROCEDURE

EQUIPMENT USED

For the first part of the characterisation procedure, the probe is placed in an isotropy measurement jig as pictured in Figure 2. In this position the probe can be rotated about its axis by a non-metallic belt driven by a stepper motor.

The probe is attached via its amplifier and an optical cable to a PC. A schematic representation of the test geometry is illustrated in Figure 3.

A balanced dipole (900 MHz) is inserted horizontally into the bracket attached to a second belt (Figure 2). The dipole can also be rotated about its axis. A cable connects the dipole to a signal generator, via a directional coupler and power meter. The signal generator feeds an RF amplifier at constant power, the output of which is monitored using the power meter. The probe is positioned so that its sensors line up with the rotation center of the source dipole. By recording output voltage measurements of each channel as both the probe and the dipole are rotated, data are obtained from which the spherical isotropy of the probe can be optimised and its magnitude determined.

The calibration process requires E-field measurements to be taken in air, in 900 MHz simulated brain liquid and at other frequencies/liquids as appropriate.

LINEARISING PROBE OUTPUT

The probe channel output signals are linearised in the manner set out in Refs [1] and [2]. The following equation is utilized for each channel:

$$U_{lin} = U_{o/p} + U_{o/p}^2 / DCP \quad (1)$$

where U_{lin} is the linearised signal, $U_{o/p}$ is the raw output signal in voltage units and DCP is the diode compression potential in similar voltage units.

DCP is determined from fitting equation (1) to measurements of U_{lin} versus source feed power over the full dynamic range of the probe. The DCP is a characteristic of the schottky diodes used as the sensors. For the IXP-050 probes with CW signals the DCP values are typically 0.10V (or 20 in the voltage units used by IndexSar software, which are $V*200$).

SELECTING CHANNEL SENSITIVITY FACTORS TO OPTIMISE ISOTROPIC RESPONSE

The basic measurements obtained using the calibration jig (Fig 2) represent the output from each diode sensor as a function of the presentation angle of the source (probe and dipole rotation angles). The directionality of the orthogonally-arranged sensors can be checked by analysing the data using dedicated IndexSar software, which displays the data in 3D format as in Figure 4. The left-hand side of this diagram shows the individual channel outputs after linearisation (see above). The program uses these data to balance the channel outputs and then applies an optimisation process, which makes fine adjustments to the channel factors for optimum isotropic response.



2.6 SAR MEASUREMENT SYSTEM

PROBE CALIBRATION PROCEDURE - Continued

The next stage of the process is to calibrate the IndexSar probe to a W&G EMR300 E-field meter in air. The principal reasons for this are to obtain conversion factors applicable should the probe be used in air and to provide an overall measure of the probe sensitivity.

A multiplier is applied to factors to bring the magnitudes of the average E-field measurements as close as possible to those of the W&G probe.

The following equation is used (where linearised output voltages are in units of V*200):

$$E_{air}^2 \text{ (V/m)} = U_{linx} * \text{Air Factor}_x + U_{liny} * \text{Air Factor}_y + U_{linz} * \text{Air Factor}_z \quad (2)$$

It should be noted that the air factors are not separately used for normal SAR testing. The IXP-050 probes are optimised for use in tissue-simulating liquids and do not behave isotropically in air.

900 MHz LIQUID CALIBRATION

Conversion factors for use when the probes are immersed in tissue-simulant liquids at 900 MHz are determined either using a waveguide or by comparison to a reference probe that has been calibrated by NPL. Waveguide procedures are described later. The summary sheet indicates the method used for the probe S/N 0084.

The conversion factor, referred to as the 'liquid factor' is also applied to the measurements of each channel. The following equation is used (where output voltages are in units of V*200):

$$E_{liq}^2 \text{ (V/m)} = U_{linx} * \text{Air Factor}_x * \text{Liq Factor}_x + U_{liny} * \text{Air Factor}_y * \text{Liq Factor}_y + U_{linz} * \text{Air Factor}_z * \text{Liq Factor}_z \quad (3)$$

A 3D representation of the spherical isotropy for probe S/N 0084 using these factors is shown in Figure 4

The rotational isotropy can also be determined from the calibration jig measurements and is reported as the 900MHz isotropy in the summary table. Note that waveguide measurements can also be used to determine rotational isotropy (Fig. 6).

The design of the cells used for determining probe conversion factors are waveguide cells is shown in Figure 5. The cells consist of a coax to waveguide transition and an open-ended section of waveguide containing a dielectric separator. Each waveguide cell stands in the upright position and is filled with liquid within 10 mm of the open end. The separator provides a liquid seal and is designed for a good electrical transition from air filled guide to liquid filled guide. The choice of cell depends on the portion of the frequency band to be examined and the choice of liquid used. The depth of liquid ensures there is negligible radiation from the waveguide open top and that the probe calibration is not influenced by reflections from nearby objects. The return loss at the coaxial connector of the filled waveguide cell is measured initially using a network analyser and this information is used subsequently in the calibration procedure. The probe is positioned in the centre of the waveguide and is adjusted vertically or rotated using stepper motor arrangements. The signal generator is connected to the waveguide cell and the power is monitored with a coupler and a power meter. A fuller description of the waveguide method is given below.



2.6 SAR MEASUREMENT SYSTEM

PROBE CALIBRATION PROCEDURE - Continued

The liquid dielectric parameters used for the probe calibrations are listed in the tables below. The final calibration factors for the probe are listed in the summary chart.

WAVEGUIDE MEASUREMENT PROCEDURE

The calibration method is based on setting up a calculable specific absorption rate (SAR) in a vertically-mounted WG8 (R22) waveguide section [1]. The waveguide has an air-filled, launcher section and a liquid-filled section separated by a matching window that is designed to minimise reflections at the liquid interface. A TE_{01} mode is launched into the waveguide by means of a N-type-to-waveguide adapter. The power delivered to the liquid section is calculated from the forward power and reflection coefficient measured at the input to the waveguide. At the centre of the cross-section of the waveguide, the local spot SAR in the liquid as a function of distance from the window is given by functions set out in IEEE 1528 as below:

Because of the low cutoff frequency, the field inside the liquid nearly propagates as a TEM wave. The depth of the medium (greater than three penetration depths) ensures that reflections at the upper surface of the liquid are negligible. The power absorbed in the liquid is determined by measuring the waveguide forward and reflected power. Equation (4) shows the relationship between the SAR at the cross-sectional center of the lossy waveguide and the longitudinal distance (z) from the dielectric separator

$$SAR(z) = \frac{4(P_f - P_b)}{\rho ab \delta} e^{-2z/\delta} \quad (4)$$

where the density ρ is conventionally assumed to be 1000 kg/m^3 , ab is the cross-sectional area of the waveguide, P_f and P_b are the forward and reflected power inside the lossless section of the waveguide, respectively. The penetration depth δ , which is the reciprocal of the waveguide-mode attenuation coefficient, is determined from a scan along the z -axis and compared with the theoretical value determined from Equation (5) using the measured dielectric properties of the lossy liquid.

$$\delta = \left[\text{Re} \left\{ \sqrt{(\pi/a)^2 + j\omega\mu_o(\sigma + j\omega\epsilon_o\epsilon_r)} \right\} \right]^{-1} \quad (5)$$

Table A.1 of [1] can be used for designing calibration waveguides with a return loss greater than 30 dB at the most important frequencies used for personal wireless communications. Values for the penetration depth for these specific fixtures and tissue-simulating mixtures are also listed in Table A.1.

According to [1], this calibration technique provides excellent accuracy, with standard uncertainty of less than 3.6% depending on the frequency and medium. The calibration itself is reduced to power measurements traceable to a standard calibration procedure. The practical limitation to the frequency band of 800 to 2500 MHz because of the waveguide size is not severe in the context of compliance testing.



2.6 SAR MEASUREMENT SYSTEM

PROBE CALIBRATION PROCEDURE - Continued

CALIBRATION FACTORS MEASURED FOR PROBE S/N 0084

The probe was calibrated at 900, 1800, 1900 and 2450MHz in liquid samples representing both brain liquid and body fluid at these frequencies. The calibration was for CW signals only, and the axis of the probe was parallel to the direction of propagation of the incident field i.e. end-on to the incident radiation. The axial isotropy of the probe was measured by rotating the probe about its axis in 10 degree steps through 360 degrees in this orientation.

The reference point for the calibration is in the centre of the probe's cross-section at a distance of 2.7 mm from the probe tip in the direction of the probe amplifier. A value of 2.7 mm should be used for the tip to sensor offset distance in the software.

It is important that the diode compression point and air factors used in the software are the same as those quoted in the results tables, as these are used to convert the diode output voltages to a SAR value.

DIELECTRIC PROPERTIES OF LIQUIDS

The dielectric properties of the brain and body tissue-simulant liquids employed for calibration are listed in the tables below. The measurements were performed prior to each waveguide test using an IndexSar DiLine measurement kit, which uses the TEM method as recommended in [2].

AMBIENT CONDITIONS

Measurements were made in the open laboratory at $22 \pm 2.0^\circ\text{C}$. The temperature of the liquids in the waveguide used was measured using a mercury thermometer.

RESPONSE TO MODULATED SIGNALS

To measure the response of the probe and amplifier to modulated signals, the probe is held vertically in a liquid-filled waveguide.

An RF amplifier is allowed to warm up and stabilise before use. A spectrum analyser is used to demonstrate that the peak power of the RF amplifier for the CW signals and the pulsed signals are within 0.1dB of each other when the signal generator is switched from CW to modulated output. Subsequently, the power levels recorded are read from a power meter when a CW signal is being transmitted.

The test sequence involves manually stepping the power up in regular (e.g. 2 dB) steps from the lowest power that gives a measurable reading on the SAR probe up to the maximum that the amplifiers can deliver.

At each power level, the individual channel outputs from the SAR probe are recorded at CW and then recorded again with the modulation setting. The results are entered into a spreadsheet. Using the spreadsheets, the modulated power is calculated by applying a factor to the measured CW power (e.g. for GSM, this factor is 9.03dB). This process is repeated 3 times with the response maximised for each channel sensor in turn.



2.6 SAR MEASUREMENT SYSTEM

PROBE CALIBRATION PROCEDURE - Continued

The probe channel output signals are linearised in the manner set out in Section 1 above using equation (1) with the DCPs determined from the linearisation procedure. Calibration factors for the probe are used to determine the E-field values corresponding to the probe readings using equation (3). SAR is determined from the equation

$$\text{SAR (W/kg)} = E_{\text{liq}}^2 \text{ (V/m)} * \sigma \text{ (S/m)} / 1000 \quad (6)$$

Where σ is the conductivity of the simulant liquid employed.

Using the spreadsheet data, the DCP value for linearising each of the individual channels (X, Y and Z) is assessed separately. The corresponding DCP values are listed in the summary page of the calibration factors for each probe.

Figure 9 shows the linearised probe response to 900MHz GSM signals, Figure 9a the response to 1800MHz GSM signals, Figure 10 the response to GPRS signals (GSM with 2 timeslots) and Figure 11 & 12 the response to CDMA IS-95A and W-CDMA signals.

Additional tests have shown that the modulation response is similar at 1800MHz and is not affected by the orientation between the source and the probe.



2.6 SAR MEASUREMENT SYSTEM

PROBE CALIBRATION PROCEDURE - Continued

SUMMARY OF CALIBRATION FACTORS FOR PROBE IXP-050 S/N 0084

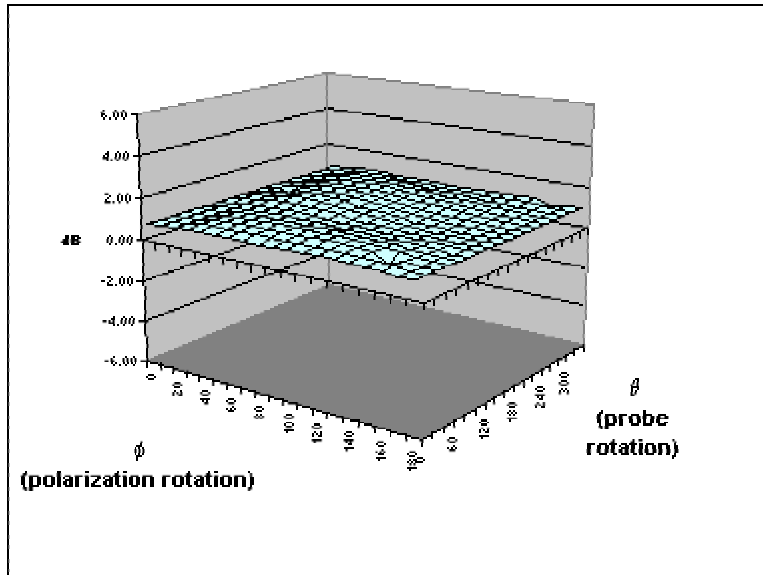

	X	Y	Z	
Air factors	500	410	385	(V*200)
DCPs	20	20	20	(V*200)
GSM	10.9	13	11.4	(V*200)
GPRS	16.1	16.1	14.7	(V*200)
CDMA	20	20	20	(V*200)

f (MHz)	Axial isotropy (+/- dB)		SAR conversion factors(liq/air)		Notes
	BRAIN	BODY	BRAIN	BODY	
900	0.09	0.09	0.279	0.300	3,4
1800	0.12	0.10	0.342	0.375	3,4
1900	0.13	0.10	0.354	0.405	3,4
2450	0.12	0.09	0.396	0.468	3,4

Notes	
1)	Calibrations done at 22C +/- 2C
2)	Probe calibration by substitution against NPL-calibrated probe (Probe IXP-050 S/N0071; NPL Cal Rept. No: EF07/2002/03/IndexSar
3)	Waveguide calibration
4)	Checked using box-phantom validation test

(The graph shows a simple, spreadsheet representation of surface shown in 3D in Figure 4)

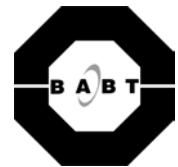

2.6 SAR MEASUREMENT SYSTEM

PROBE CALIBRATION PROCEDURE - Continued

PROBE SPECIFICATIONS

IndexSar probe 0084, along with its calibration, is compared with CENELEC and IEEE standards recommendations (Refs [1] and [2]) in the Tables below. A listing of relevant specifications is contained in the tables below:

DIMENSIONS	S/N 0084	CENELEC [1]	IEEE [2]
Overall length (mm)	350	-	-
Tip length (mm)	10	-	-
Body diameter (mm)	12	-	-
Tip diameter (mm)	5.2	8	8
Distance from probe tip to dipole centers (mm)	2.7	-	-

DYNAMIC RANGE	S/N 0084	CENELEC [1]	IEEE [2]
Minimum (W/kg)	0.01	<0.02	0.01
Maximum (W/kg)	>100	>100	100

LINEARITY OF RESPONSE	S/N 0084	CENELEC [1]	IEEE [2]
Over range 0.01 – 100 W/kg (+/- dB)	0.125	0.50	0.25

Isotropy (measured at 900MHz)	S/N 0084	CENELEC [1]	IEEE [2]
Axial rotation with probe normal to source (+/- dB) at 900, 1800, 1900 and 2450 MHz	Max. 0.13 (see summary table)	0.5	0.25
Spherical isotropy covering all orientations to source (+/- dB)	0.34	1.0	0.50

CONSTRUCTION	Each probe contains three orthogonal dipole sensors arranged on a triangular prism core, protected against static charges by built-in shielding, and covered at the tip by PEEK cylindrical enclosure material. No adhesives are used in the immersed section. Outer case materials are PEEK and heat-shrink sleeving.
CHEMICAL RESISTANCE	Tested to be resistant to glycol and alcohol containing simulant liquids but probes should be removed, cleaned and dried when not in use.

2.6 SAR MEASUREMENT SYSTEM

PROBE CALIBRATION PROCEDURE - Continued

REFERENCES

- [1] CENELEC, EN 50361, July 2001. Basic Standard for the measurement of specific absorption rate related to human exposure to electromagnetic fields from mobile phones.
- [2] IEEE 1528, Recommended practice for determining the spatial-peak specific absorption rate (SAR) in the human body due to wireless communications devices: Experimental techniques.
- [3] Calibration report on SAR probe IXP-050 S/N 0071 from National Physical Laboratory. Test Report EF07/2002/03/IndexSar. Dated 20 February 2002.

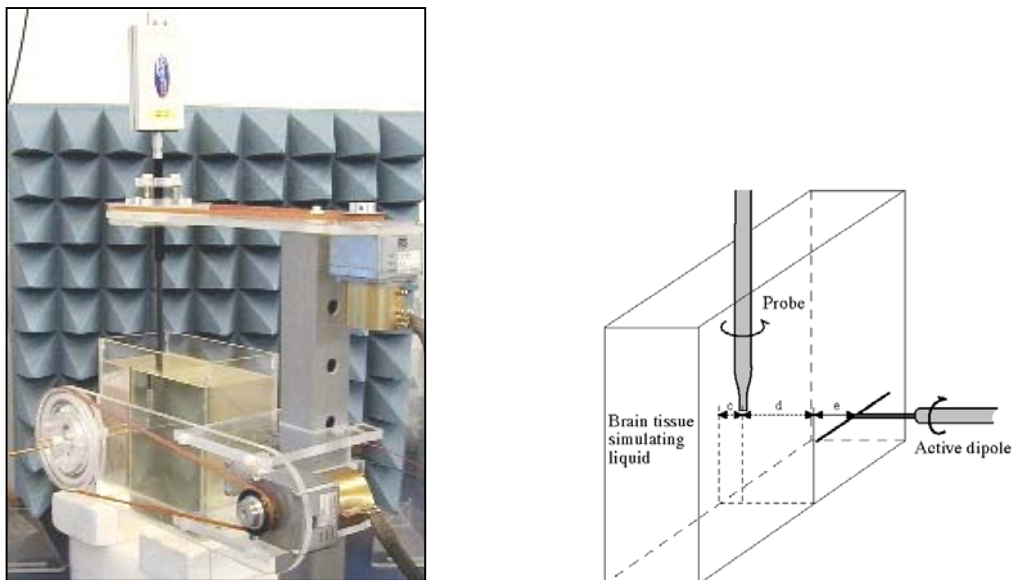

Figure 2. Spherical isotropy jig showing probe, dipole and box filled with simulated brain liquid (see Ref [2], Section A.5.2.1)

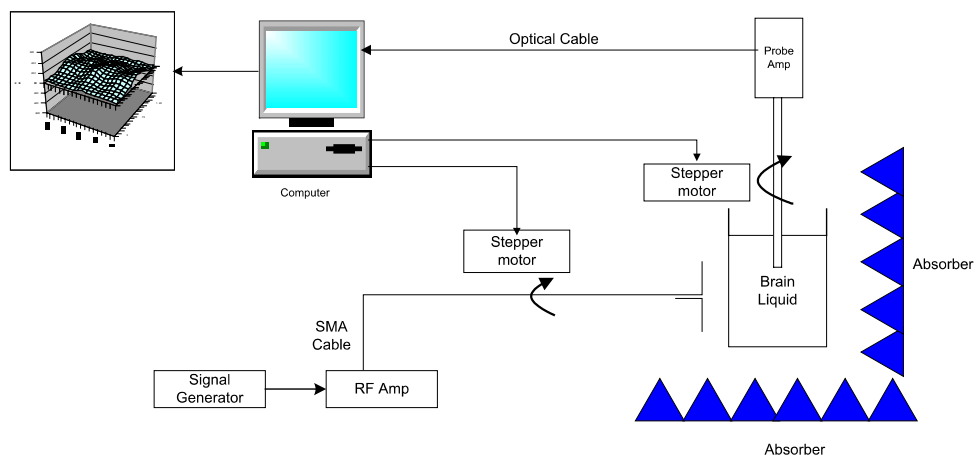

Figure 3. Schematic diagram of the test geometry used for isotropy determination



2.6 SAR MEASUREMENT SYSTEM

PROBE CALIBRATION PROCEDURE - Continued

REFERENCES

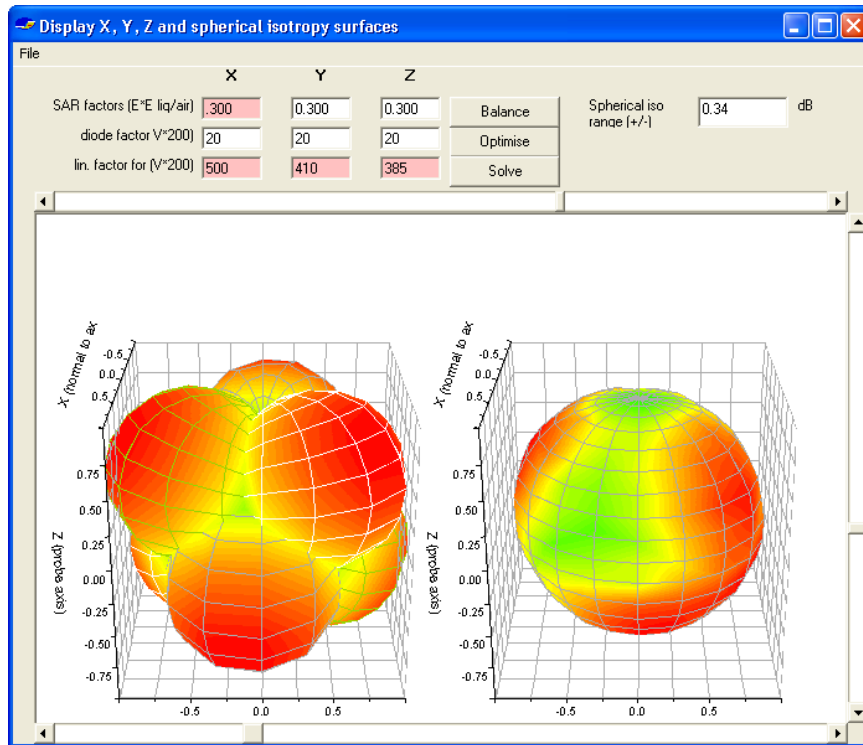

Figure 4. Graphical representation of the probe response to fields applied from each direction. The diagram on the left shows the individual response characteristics of each of the three channels and the diagram on the right shows the resulting probe sensitivity in each direction. The colour range in the figure images the lowest values as blue and the maximum values as red. For the probe S/N 0084, this range is (+/-) 0.34 dB. The probe is more sensitive to fields parallel to the axis and less sensitive to fields normal to the probe axis.

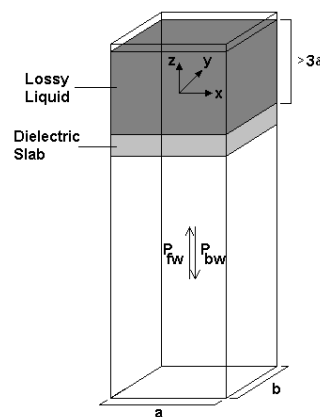

Figure 5. Geometry used for waveguide calibration (after Ref [2]. Section A.3.2.2)



2.6 SAR MEASUREMENT SYSTEM

PROBE CALIBRATION PROCEDURE - Continued

REFERENCES

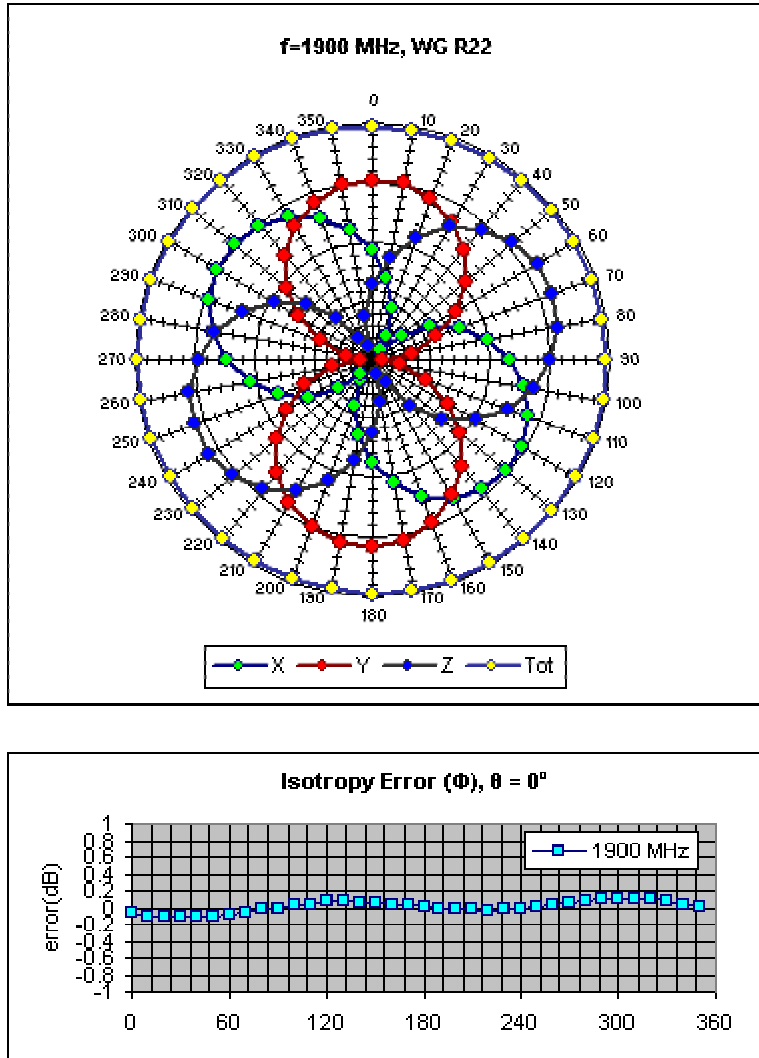

Figure 6. Example of the rotational isotropy of probe S/N 0084 obtained by rotating the probe in a liquid-filled waveguide at 1800 MHz. Similar distributions are obtained at the other test frequencies (900, 1900 and 2450 MHz) both in brain liquids and body fluids (see summary table)



2.6 SAR MEASUREMENT SYSTEM

PROBE CALIBRATION PROCEDURE - Continued

REFERENCES

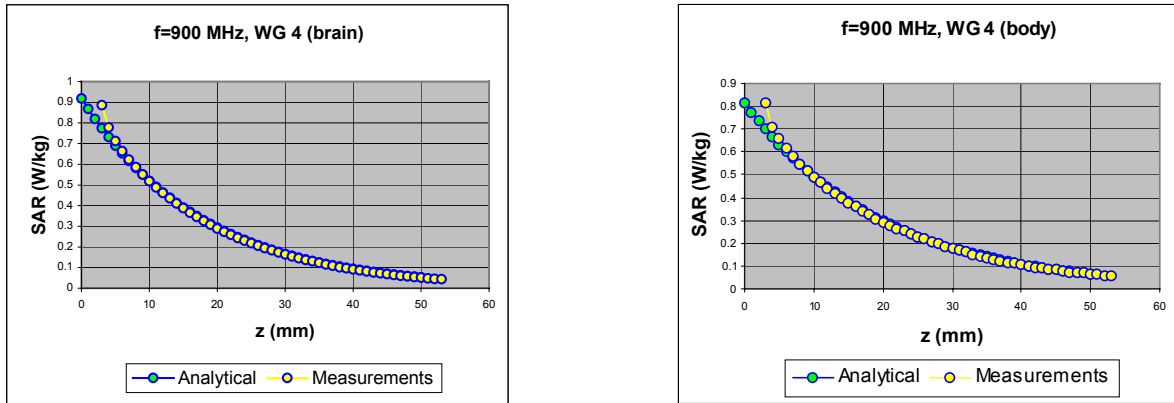

Figure 7. The measured SAR decay function along the centreline of the WG4 waveguide with conversion factors adjusted to fit to the theoretical function for the particular dimension, frequency, power and liquid properties employed.

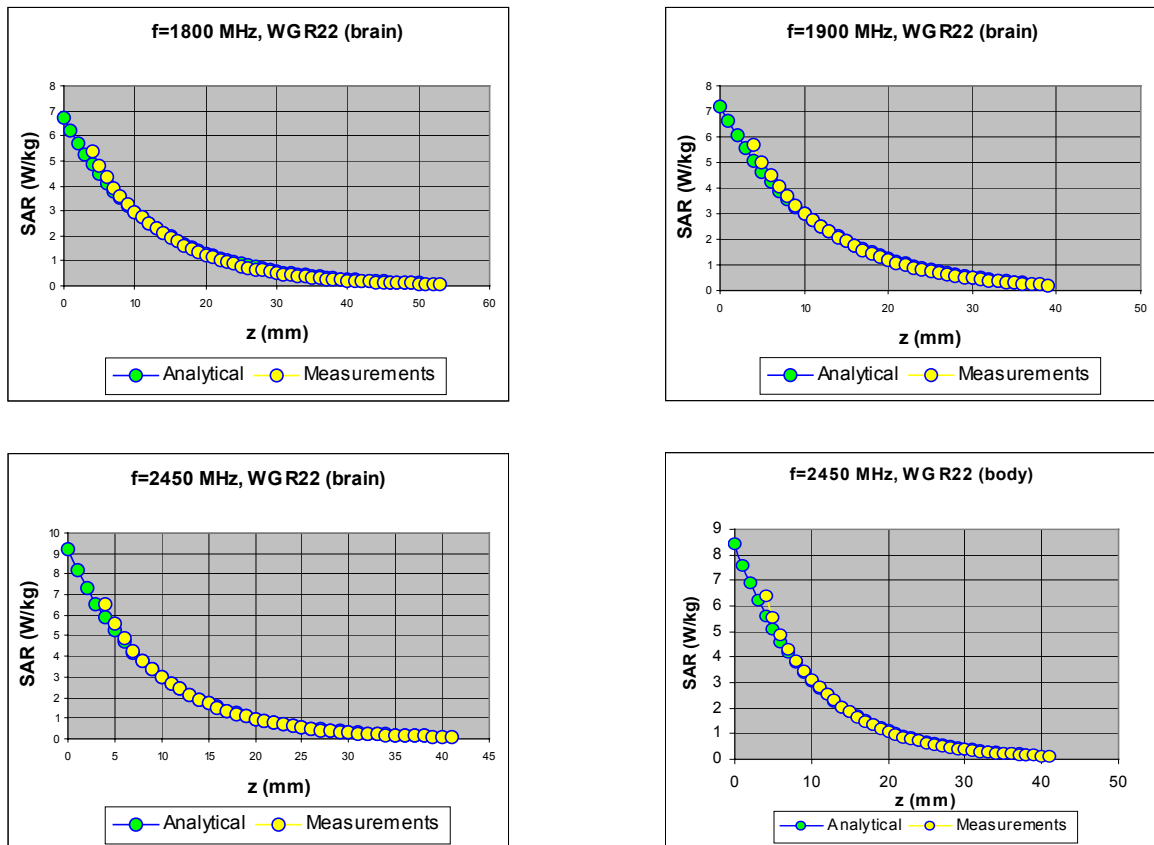

Figure 8. The measured SAR decay function along the centreline of the R22 waveguide with conversion factors adjusted to fit to the theoretical function for the particular dimension, frequency, power and liquid properties employed.



2.6 SAR MEASUREMENT SYSTEM

PROBE CALIBRATION PROCEDURE - Continued

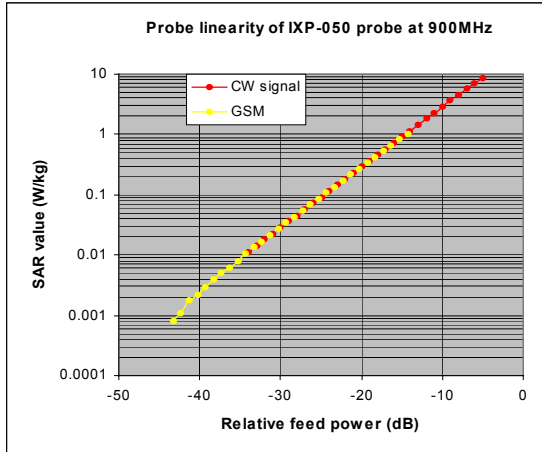

Figure 9. The GSM response of an IXP-050 probe at 900MHz

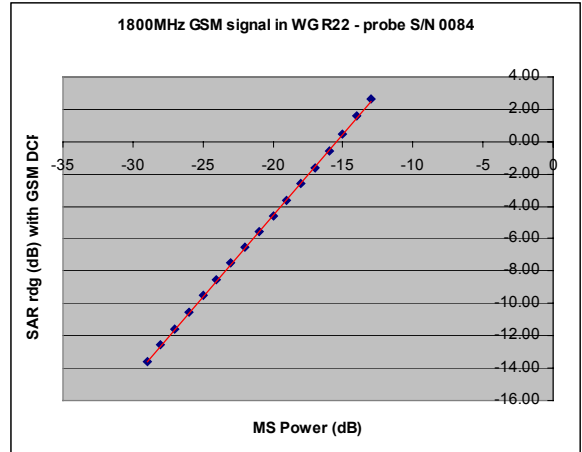

Figure 9a. The actual GSM response of IXP-050 probe S/N 0084 at 1800MHz.

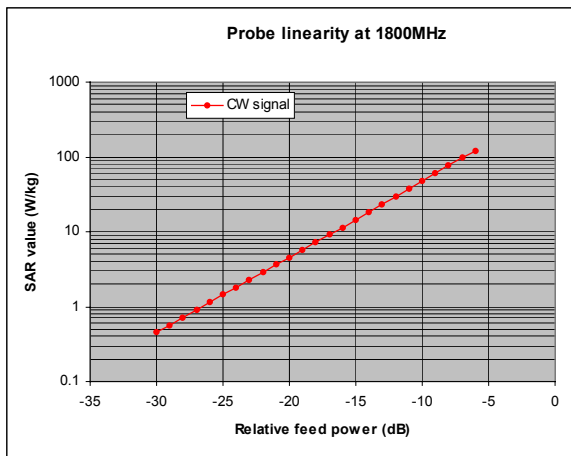

Figure 9b. The actual CW response of IXP-050 probe SN0084 up to 100W/kg

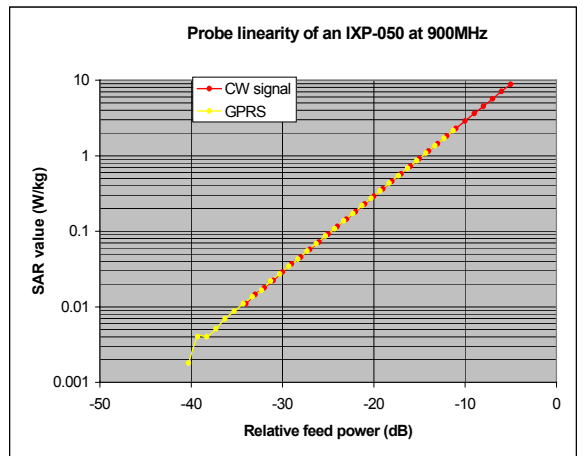

Figure 10. The GPRS response of an IXP-050 probe at 900MHz.



2.6 SAR MEASUREMENT SYSTEM

PROBE CALIBRATION PROCEDURE - Continued

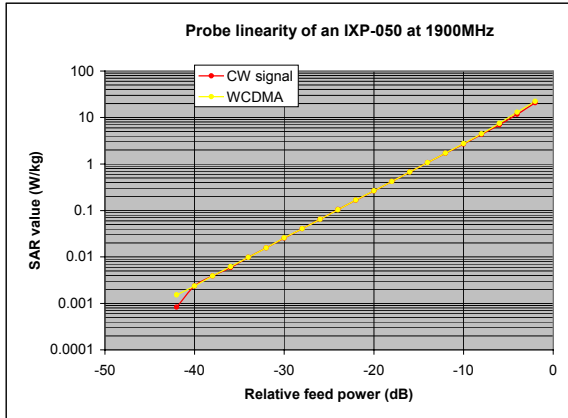

Figure 11. The WCDMA response of an IXP-050 probe at 1900MHz.

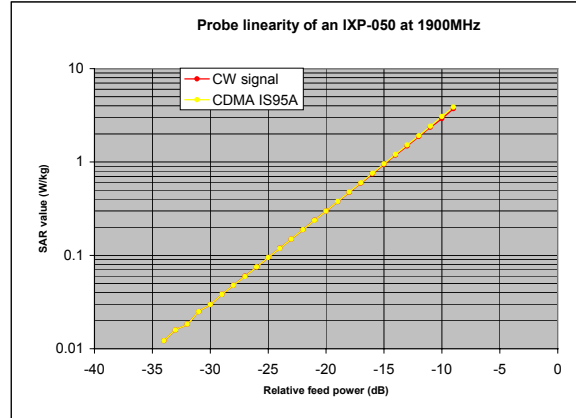

Figure 12. The CDMA IS95A response of an IXP-050 probe at 1900MHz.

TABLE INDICATING THE DIELECTRIC PARAMETERS OF THE LIQUIDS USED FOR CALIBRATIONS AT EACH FREQUENCY

Liquid used	Relative permittivity (measured)	Conductivity (S/m) (measured)
900 MHz BRAIN	41.80	1.000
900 MHz BODY	57.50	1.031
1800 MHz BRAIN	38.64	1.380
1800 MHz BODY	54.30	1.587
1900 MHz BRAIN	38.12	1.470
1900 MHz BODY	52.97	1.460
2450 MHz BRAIN	38.67	1.881
2450 MHz BODY	52.19	1.949



2.6 SAR MEASUREMENT SYSTEM

SAR MEASUREMENT PROCEDURE

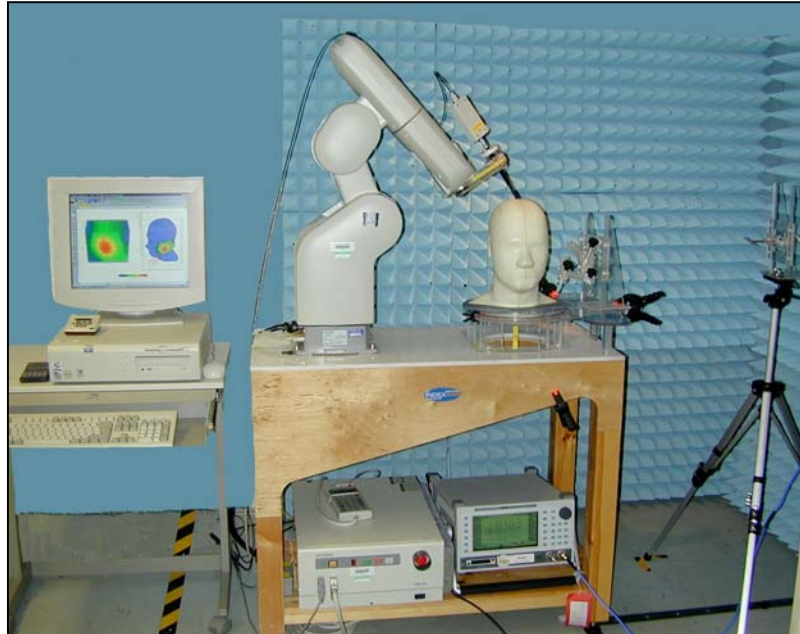

Figure 13: Principal components of the SAR measurement test bench

The major components of the test bench are shown in the picture above. A test set and dipole antenna control the handset via an air link and a low-mass phone holder can position the phone at either ear. Graduated scales are provided to set the phone in the 15 degree position. The upright phantom head holds approx. 7 litres of simulant liquid. The phantom is filled and emptied through a 45mm diameter penetration hole in the top of the head.

After an area scan has been done at a fixed distance of 8mm from the surface of the phantom on the source side, a 3D scan is set up around the location of the maximum spot SAR. First, a point within the scan area is visited by the probe and a SAR reading taken at the start of testing. At the end of testing, the probe is returned to the same point and a second reading is taken. Comparison between these start and end readings enables the power drift during measurement to be assessed.

SARA2 Interpolation and Extrapolation schemes

SARA2 software contains support for both 2D cubic B-spline interpolation as well as 3D cubic B-spline interpolation. In addition, for extrapolation purposes, a general n^{th} order polynomial fitting routine is implemented following a singular value decomposition algorithm presented in [4]. A 4th order polynomial fit is used by default for data extrapolation, but a linear-logarithmic fitting function can be selected as an option. The polynomial fitting procedures have been tested by comparing the fitting coefficients generated by the SARA2 procedures with those obtained using the polynomial fit functions of Microsoft Excel when applied to the same test input data.

Interpolation of 2D area scan

The 2D cubic B-spline interpolation is used after the initial area scan at fixed distance from the phantom shell wall. The initial scan data are collected with approx. 10mm spatial resolution and spline interpolation is used to find the location of the local maximum to within a 1mm resolution for positioning the subsequent 3D scanning.



2.6 SAR MEASUREMENT SYSTEM

SAR MEASUREMENT PROCEDURE - Continued

Extrapolation of 3D scan

For the 3D scan, data are collected on a spatially regular 3D grid having (by default) 6.4 mm steps in the lateral dimensions and 3.5 mm steps in the depth direction (away from the source). SARA2 enables full control over the selection of alternative step sizes in all directions.

The digitised shape of the head is available to the SARA2 software, which decides which points in the 3D array are sufficiently well within the shell wall to be 'visited' by the SAR probe. After the data collection, the data are extrapolated in the depth direction to assign values to points in the 3D array closer to the shell wall. A notional extrapolation value is also assigned to the first point outside the shell wall so that subsequent interpolation schemes will be applicable right up to the shell wall boundary.

Interpolation of 3D scan and volume averaging

The procedure used for defining the shape of the volumes used for SAR averaging in the SARA2 software follow the method of adapting the surface of the 'cube' to conform with the curved inner surface of the phantom (see Appendix C.2.2.1 in EN 50361). This is called, here, the conformal scheme.

For each row of data in the depth direction, the data are extrapolated and interpolated to less than 1mm spacing and average values are calculated from the phantom surface for the row of data over distances corresponding to the requisite depth for 10g and 1g cubes. This results in two 2D arrays of data, which are then cubic B-spline interpolated to sub mm lateral resolution. A search routine then moves an averaging square around through the 2D array and records the maximum value of the corresponding 1g and 10g volume averages. For the definition of the surface in this procedure, the digitised position of the headshell surface is used for measurement in head-shaped phantoms. For measurements in rectangular, box phantoms, the distance between the phantom wall and the closest set of gridded data points is entered into the software.

For measurements in box-shaped phantoms, this distance is under the control of the user. The effective distance must be greater than 2.5mm as this is the tip-sensor distance and to avoid interface proximity effects, it should be at least 5mm. A value of 6 or 8mm is recommended. This distance is called **dbe** in EN 50361.

For automated measurements inside the head, the distance cannot be less than 2.5mm, which is the radius of the probe tip and to avoid interface proximity effects, a minimum clearance distance of x mm is retained. The actual value of **dbe** will vary from point to point depending upon how the spatially-regular 3D grid points fit within the shell. The greatest separation is when a grid point is just not visited due to the probe tip dimensions. In this case the distance could be as large as the step-size plus the minimum clearance distance (i.e with $x=5$ and a step size of 3.5, **dbe** will be between 3.5 and 8.5mm).

The default step size (**dstep** in EN 50361) used is 3.5mm, but this is under user-control. The compromise is with time of scan, so it is not practical to make it much smaller or scan times become long and power-drop influences become larger.

The robot positioning system specification for the repeatability of the positioning (**dss** in EN50361) is +/- 0.04mm.



2.6 SAR MEASUREMENT SYSTEM

SAR MEASUREMENT PROCEDURE - Continued

The phantom shell is made by an industrial moulding process from the CAD files of the SAM shape, with both internal and external moulds. For the upright phantoms, the external shape is subsequently digitised on a Mitutoyo CMM machine (Euro C574) to a precision of 0.001mm. Wall thickness measurements made non-destructively with an ultrasonic sensor indicate that the shell thickness (**dph**) away from the ear is 2.0 +/- 0.1mm. The ultrasonic measurements were calibrated using additional mechanical measurements on available cut surfaces of the phantom shells.

For the upright phantom, the alignment is based upon registration of the rotation axis of the phantom on its 253mm-diameter baseplate bearing and the position of the probe axis when commanded to go to the axial position. A laser alignment tool is provided (procedure detailed elsewhere). This enables the registration of the phantom tip (**dmis**) to be assured to within approx. 0.2mm. This alignment is done with reference to the actual probe tip after installation and probe alignment. The rotational positioning of the phantom is variable – offering advantages for special studies, but locating pins ensure accurate repositioning at the principal positions (LH and RH ears).



2.7 TEST POSITIONS

This recommended practice specifies exactly two test positions for the handset against the head phantom, the “cheek” position and the “tilted” position. These two test positions are defined in the following sub-clauses. The handset should be tested in both positions on the left and right sides of the SAM phantom. In each test position the centre of the earpiece of the device is placed directly at the entrance of the auditory canal. The angles mentioned in the test positions used are referenced to the line connecting both auditory canal openings. The plane this line is on is known as the reference plane. Testing is performed on the right and left-hand sides of the generic phantom head.

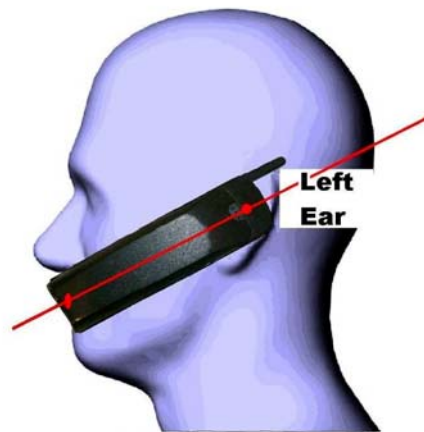

Figure 14. – Side View of Mobile next to head showing alignment.

The Cheek Position

The Cheek Position is where the mobile is in the reference plane and the line between the mobile and the line connecting both auditory canal openings is reduced until any part of the mobile touches any part of the generic twin phantom head.

The 15° Position

The 15° Position is where the mobile is in the reference cheek position and the phone is kept in contact with the auditory canal at the earpiece, the bottom of the phone is then tilted away from the phantom mouth by 15°.



Figure 15. – Cheek Position.

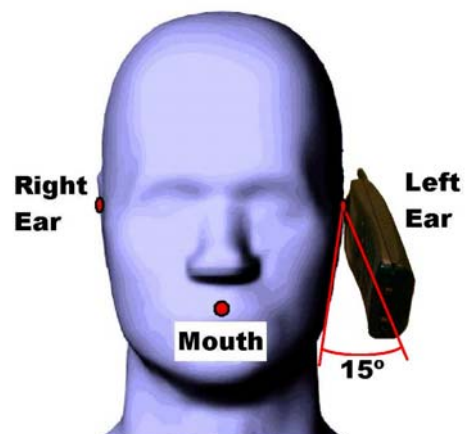

Figure 16. – 15° Tilt Position.

2.7 TEST POSITIONS

OET65(c) FLAT PHANTOM TEST POSITIONS – INTENDED and ALTERNATIVE



Figure 17. Positional photograph of the Intermec 700C
Normal user position holster 1



Figure 18. Positional photograph of the Intermec 700C
Inverted user position holster 1



Figure 19. Positional photograph of the Intermec 700C
Inverted position holster 1 rear facing



2.7 TEST POSITIONS

OET65(c) FLAT PHANTOM TEST POSITIONS – INTENDED and ALTERNATIVE



Figure 20. Positional photograph of the Intermec 700C Normal user position holster 2



Figure 21. Positional photograph of the Intermec 700C Inverted position holster 2



Figure 22. Positional photograph of the Intermec 700C Inverted position holster 2 (rear facing)



2.7 TEST POSITIONS

OET65(c) FLAT PHANTOM TEST POSITIONS – INTENDED and ALTERNATIVE



Figure 23. Positional photograph of the Intermec 700C
Normal side user position



Figure 24. Positional photograph of the Intermec 700C
Inverted side position



Figure 25. Positional photograph of the Intermec 700C
Normal side user position



Figure 26. Positional photograph of the Intermec 700C
Inverted side position



2.7 TEST POSITIONS

OET65(c) FLAT PHANTOM TEST POSITIONS – INTENDED and ALTERNATIVE



Figure 27. Positional photograph of the Intermec 700C Normal user position holster 2



Figure 28. Positional photograph of the Intermec 700C Inverted position holster 2



Figure 29. Positional photograph of the Intermec 700C Inverted user position holster 2

OET65(c) FLAT PHANTOM TEST POSITIONS – INTENDED and ALTERNATIVE

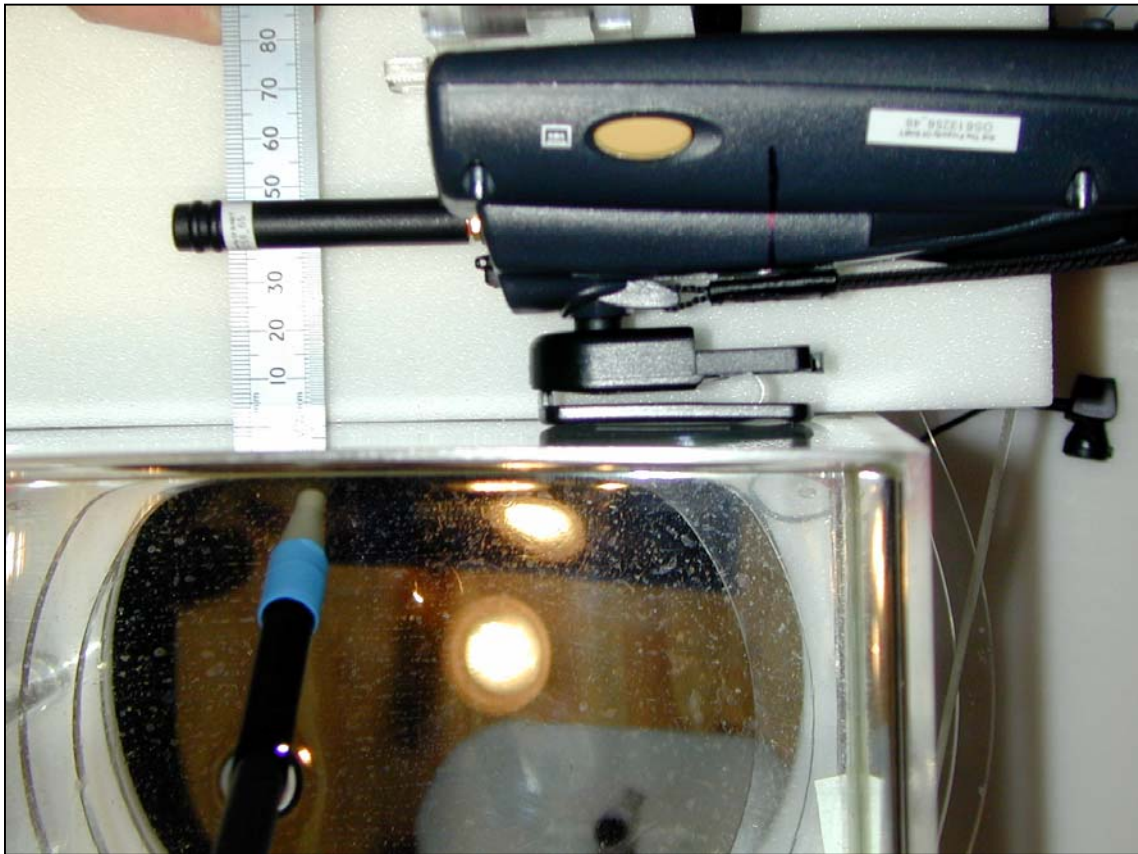

Figure 30. – Intermec 700C rear facing from phantom side representing use of belt clip



2.8 TEST RESULTS INCLUDING SAR DISTRIBUTIONS (AREA SCANS – 2D)

SYSTEM / SOFTWARE:	SARA2 / 2.3 VPM	INPUT POWER DRIFT:	0.0dBm
DATE / TIME:	15/11/2004 14:59:52	DUT BATTERY MODEL/NO:	318-103-002
FILENAME:	613256_02_001.txt	PROBE SERIAL NUMBER:	0084
AMBIENT TEMPERATURE:	24.9°C	LIQUID SIMULANT:	835 Head
DEVICE UNDER TEST:	Intermec 700CXL	RELATIVE PERMITTIVITY:	42.6
RELATIVE HUMIDITY:	28.8%	CONDUCTIVITY:	0.913
PHANTOM S/NO:	HeadFT04.csv	LIQUID TEMPERATURE:	23.5°C
PHANTOM ROTATION:	0°	MAX SAR Y-AXIS LOCATION:	-42.30 mm
DUT POSITION:	Left Hand Cheek	MAX SAR Z-AXIS LOCATION:	-148.25 mm
ANTENNA CONFIGURATION:	External	MAX E FIELD:	14.47 V/m
TEST FREQUENCY:	836.4MHz	SAR 1g:	0.166 W/kg
AIR FACTORS:	500 / 410 / 385	SAR 10g:	0.123 W/kg
CONVERSION FACTORS:	0.279 / 0.279 / 0.279	SAR START:	0.094 W/kg
TYPE OF MODULATION:	GSM	SAR END:	0.095 W/kg
MODN. DUTY CYCLE:	12.5%	SAR DRIFT DURING SCAN:	0.05 dB
DIODE COMPRESSION FACTORS (V*200):	10.9 / 13 / 11.4	PROBE BATTERY LAST CHANGED:	15/11/04
INPUT POWER LEVEL:	5	EXTRAPOLATION:	poly4

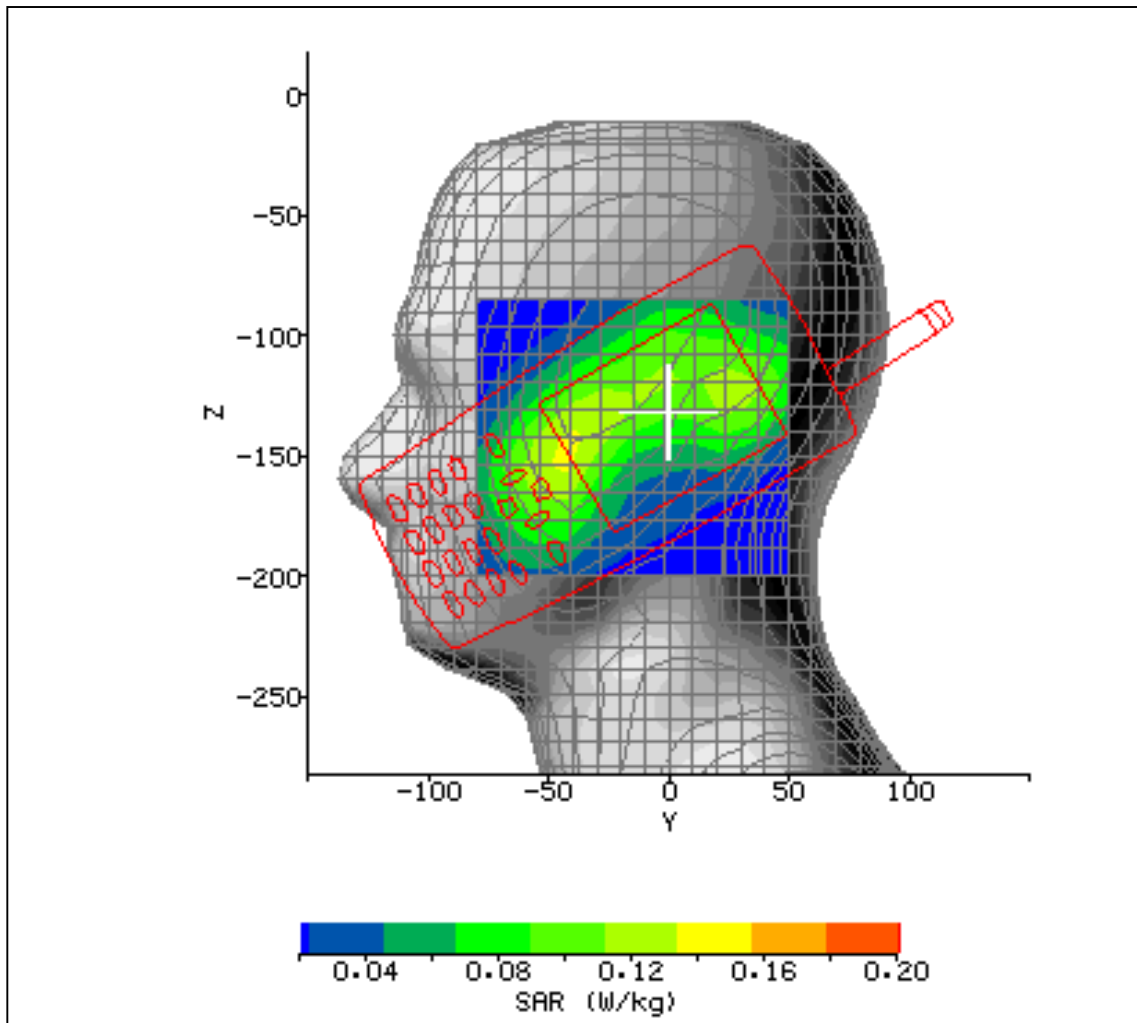

Figure 31



2.8 TEST RESULTS INCLUDING SAR DISTRIBUTIONS (AREA SCANS – 2D)

SYSTEM / SOFTWARE:	SARA2 / 2.3 VPM	INPUT POWER DRIFT:	0.0dBm
DATE / TIME:	15/11/2004 16:15:40	DUT BATTERY MODEL/NO:	318-103-002
FILENAME:	613256_02_002b.txt	PROBE SERIAL NUMBER:	0084
AMBIENT TEMPERATURE:	25.2°C	LIQUID SIMULANT:	835 Head
DEVICE UNDER TEST:	Intermec 700CXL	RELATIVE PERMITTIVITY:	42.6
RELATIVE HUMIDITY:	28.7%	CONDUCTIVITY:	0.913
PHANTOM S/NO:	HeadFT04.csv	LIQUID TEMPERATURE:	23.6°C
PHANTOM ROTATION:	30°	MAX SAR Y-AXIS LOCATION:	-2.00 mm
DUT POSITION:	Left Hand 15°	MAX SAR Z-AXIS LOCATION:	-117.20 mm
ANTENNA CONFIGURATION:	External	MAX E FIELD:	15.05 V/m
TEST FREQUENCY:	836.4MHz	SAR 1g:	0.190 W/kg
AIR FACTORS:	500 / 410 / 385	SAR 10g:	0.141 W/kg
CONVERSION FACTORS:	0.279 / 0.279 / 0.279	SAR START:	0.101 W/kg
TYPE OF MODULATION:	GSM	SAR END:	0.103 W/kg
MODN. DUTY CYCLE:	12.5%	SAR DRIFT DURING SCAN:	0.11 dB
DIODE COMPRESSION FACTORS (V*200):	10.9 / 13 / 11.4	PROBE BATTERY LAST CHANGED:	15/11/04
INPUT POWER LEVEL:	5	EXTRAPOLATION:	poly4

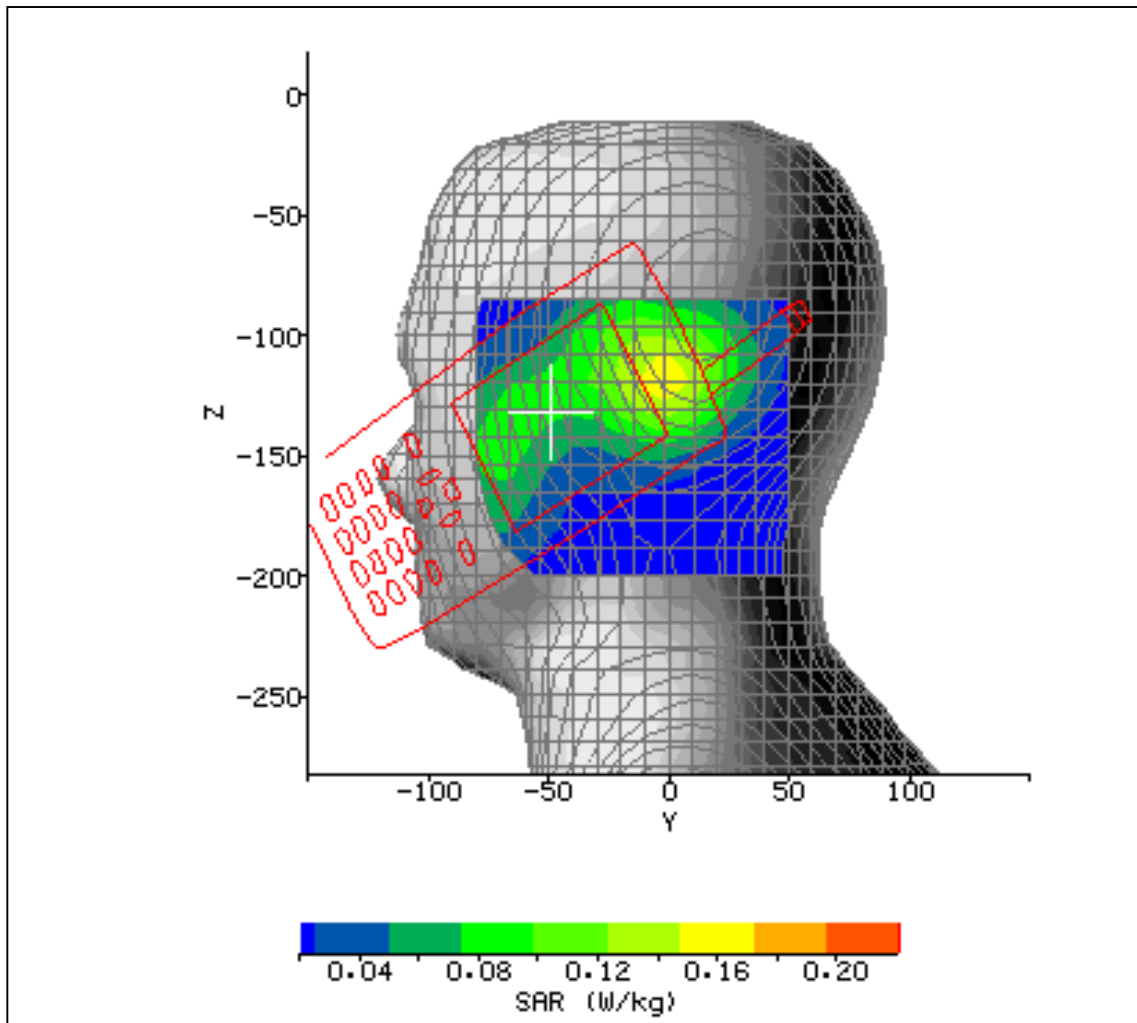

Figure 32



2.8 TEST RESULTS INCLUDING SAR DISTRIBUTIONS (AREA SCANS – 2D)

SYSTEM / SOFTWARE:	SARA2 / 2.3 VPM	INPUT POWER DRIFT:	0.0dBm
DATE / TIME:	16/11/2004 14:40:06	DUT BATTERY MODEL/NO:	318-103-002
FILENAME:	613256_02_003b.txt	PROBE SERIAL NUMBER:	0084
AMBIENT TEMPERATURE:	24.2°C	LIQUID SIMULANT:	835 Head
DEVICE UNDER TEST:	Intermec 700CXL	RELATIVE PERMITTIVITY:	42.6
RELATIVE HUMIDITY:	35.7%	CONDUCTIVITY:	0.913
PHANTOM S/NO:	Head04_36.csv	LIQUID TEMPERATURE:	24.0°C
PHANTOM ROTATION:	180°	MAX SAR Y-AXIS LOCATION:	-20.75 mm
DUT POSITION:	Right Hand Cheek	MAX SAR Z-AXIS LOCATION:	-95.90 mm
ANTENNA CONFIGURATION:	External	MAX E FIELD:	16.14 V/m
TEST FREQUENCY:	836.4MHz	SAR 1g:	0.209 W/kg
AIR FACTORS:	500 / 410 / 385	SAR 10g:	0.148 W/kg
CONVERSION FACTORS:	0.279 / 0.279 / 0.279	SAR START:	0.105 W/kg
TYPE OF MODULATION:	GSM	SAR END:	0.106 W/kg
MODN. DUTY CYCLE:	12.5%	SAR DRIFT DURING SCAN:	0.04 dB
DIODE COMPRESSION FACTORS (V*200):	10.9 / 13 / 11.4	PROBE BATTERY LAST CHANGED:	15/11/04
INPUT POWER LEVEL:	5	EXTRAPOLATION:	poly4

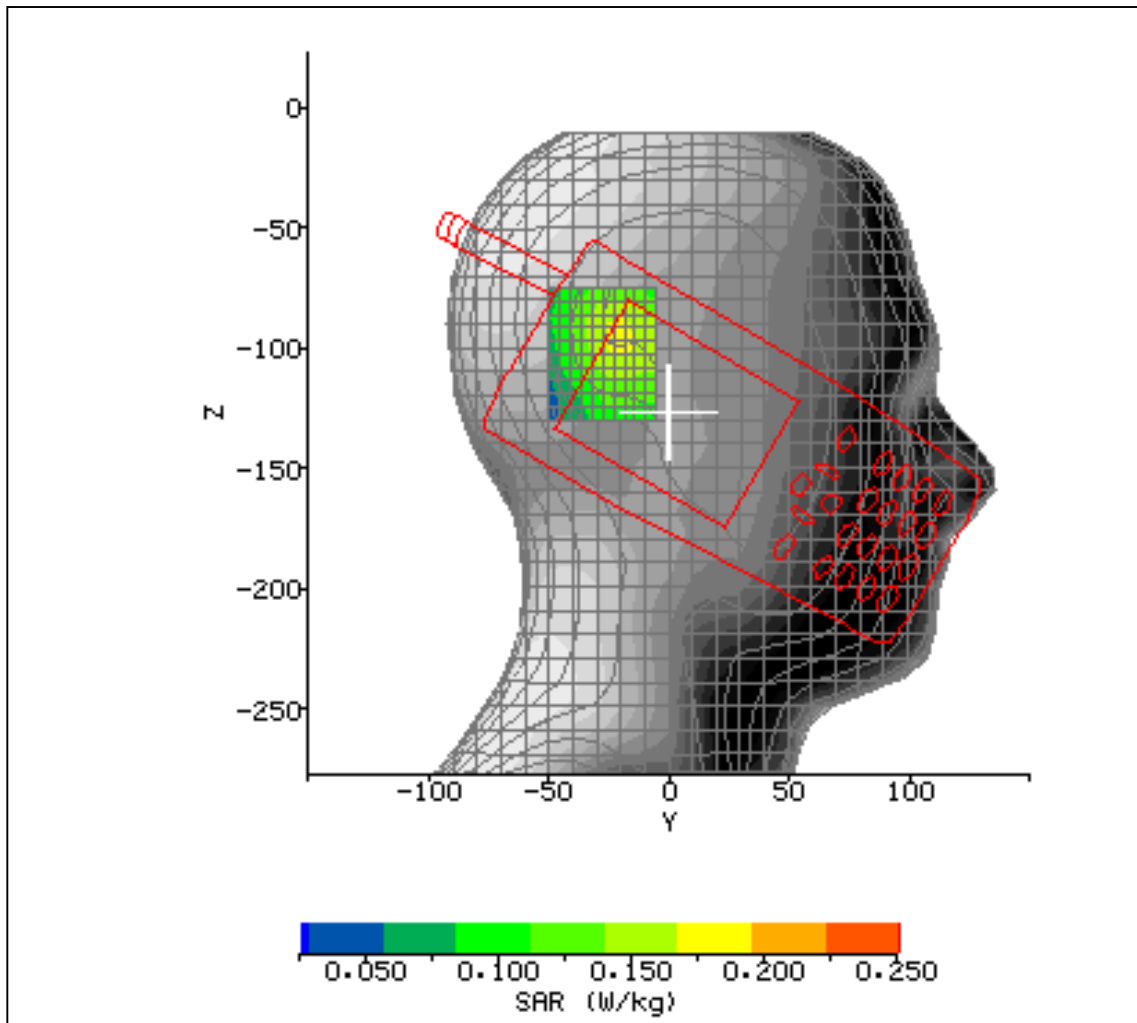

Figure 33



2.8 TEST RESULTS INCLUDING SAR DISTRIBUTIONS (AREA SCANS – 2D)

SYSTEM / SOFTWARE:	SARA2 / 2.3 VPM	INPUT POWER DRIFT:	0.0dBm
DATE / TIME:	16/11/2004 15:33:12	DUT BATTERY MODEL/NO:	318-103-002
FILENAME:	613256_02_004.txt	PROBE SERIAL NUMBER:	0084
AMBIENT TEMPERATURE:	24.3°C	LIQUID SIMULANT:	835 Head
DEVICE UNDER TEST:	Intermec 700CXL	RELATIVE PERMITTIVITY:	42.6
RELATIVE HUMIDITY:	35.7%	CONDUCTIVITY:	0.913
PHANTOM S/NO:	Head04_36.csv	LIQUID TEMPERATURE:	24.1°C
PHANTOM ROTATION:	180°	MAX SAR Y-AXIS LOCATION:	-26.00 mm
DUT POSITION:	Right Hand 15°	MAX SAR Z-AXIS LOCATION:	-93.15 mm
ANTENNA CONFIGURATION:	External	MAX E FIELD:	21.20 V/m
TEST FREQUENCY:	836.4MHz	SAR 1g:	0.355 W/kg
AIR FACTORS:	500 / 410 / 385	SAR 10g:	0.246 W/kg
CONVERSION FACTORS:	0.279 / 0.279 / 0.279	SAR START:	0.175 W/kg
TYPE OF MODULATION:	GSM	SAR END:	0.176 W/kg
MODN. DUTY CYCLE:	12.5%	SAR DRIFT DURING SCAN:	0.00 dB
DIODE COMPRESSION FACTORS (V*200):	10.9 / 13 / 11.4	PROBE BATTERY LAST CHANGED:	15/11/04
INPUT POWER LEVEL:	5	EXTRAPOLATION:	poly4

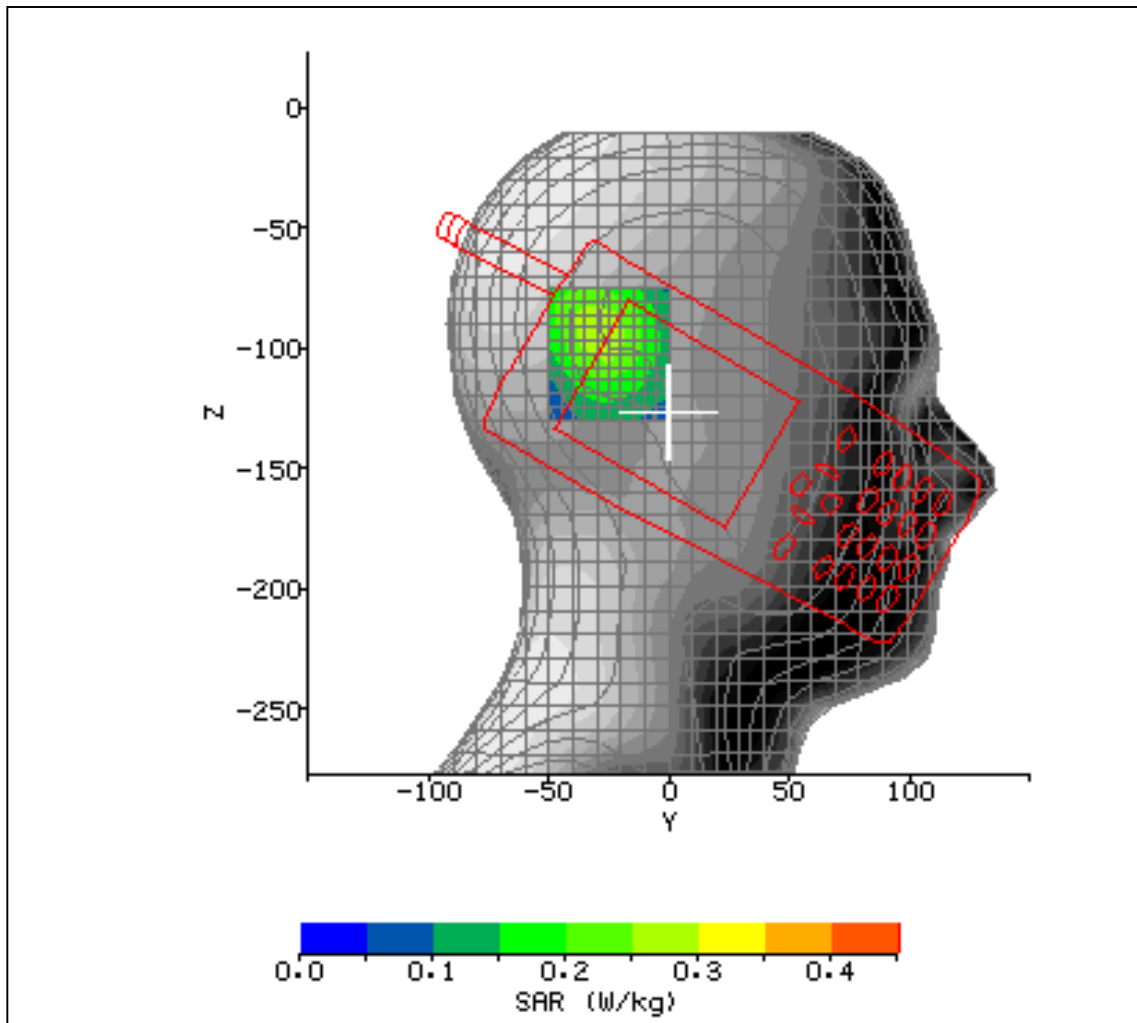

Figure 34



2.8 TEST RESULTS INCLUDING SAR DISTRIBUTIONS (AREA SCANS – 2D)

SYSTEM / SOFTWARE:	SARA2 / 2.3 VPM	INPUT POWER DRIFT:	0.0dBm
DATE / TIME:	16/11/2004 16:36:57	DUT BATTERY MODEL/NO:	318-103-002
FILENAME:	613256_02_005.txt	PROBE SERIAL NUMBER:	0084
AMBIENT TEMPERATURE:	23.9°C	LIQUID SIMULANT:	835 Head
DEVICE UNDER TEST:	Intermec 700CXL	RELATIVE PERMITTIVITY:	42.6
RELATIVE HUMIDITY:	37.3%	CONDUCTIVITY:	0.913
PHANTOM S/NO:	Head04_36.csv	LIQUID TEMPERATURE:	24°C
PHANTOM ROTATION:	180°	MAX SAR Y-AXIS LOCATION:	-30.50 mm
DUT POSITION:	Right Hand 15°	MAX SAR Z-AXIS LOCATION:	-85.00 mm
ANTENNA CONFIGURATION:	External	MAX E FIELD:	19.27 V/m
TEST FREQUENCY:	824.2MHz	SAR 1g:	0.296 W/kg
AIR FACTORS:	500 / 410 / 385	SAR 10g:	0.209 W/kg
CONVERSION FACTORS:	0.279 / 0.279 / 0.279	SAR START:	0.145 W/kg
TYPE OF MODULATION:	GSM	SAR END:	0.145 W/kg
MODN. DUTY CYCLE:	12.5%	SAR DRIFT DURING SCAN:	0.00 dB
DIODE COMPRESSION FACTORS (V*200):	10.9 / 13 / 11.4	PROBE BATTERY LAST CHANGED:	15/11/04
INPUT POWER LEVEL:	5	EXTRAPOLATION:	poly4

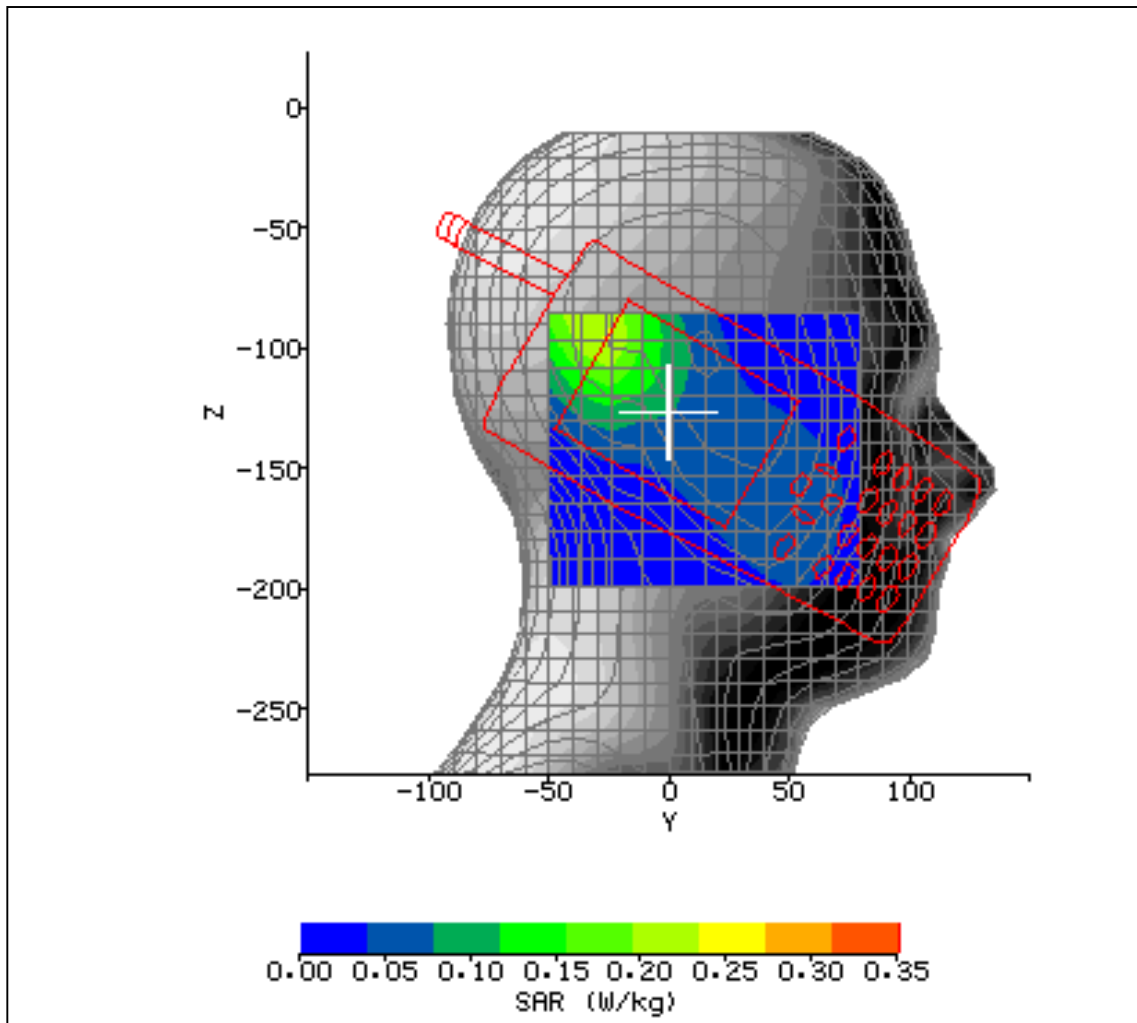

Figure 35



2.8 TEST RESULTS INCLUDING SAR DISTRIBUTIONS (AREA SCANS – 2D)

SYSTEM / SOFTWARE:	SARA2 / 2.3 VPM	INPUT POWER DRIFT:	0.0dBm
DATE / TIME:	16/11/2004 17:45:20	DUT BATTERY MODEL/NO:	318-103-002
FILENAME:	613256_02_006b.txt	PROBE SERIAL NUMBER:	0084
AMBIENT TEMPERATURE:	25.2°C	LIQUID SIMULANT:	835 Head
DEVICE UNDER TEST:	Intermec 700CXL	RELATIVE PERMITTIVITY:	42.6
RELATIVE HUMIDITY:	36.2%	CONDUCTIVITY:	0.913
PHANTOM S/NO:	Head04_36.csv	LIQUID TEMPERATURE:	24°C
PHANTOM ROTATION:	180°	MAX SAR Y-AXIS LOCATION:	-26.45 mm
DUT POSITION:	Right Hand 15°	MAX SAR Z-AXIS LOCATION:	-93.60 mm
ANTENNA CONFIGURATION:	External	MAX E FIELD:	21.08 V/m
TEST FREQUENCY:	848.8MHz	SAR 1g:	0.354 W/kg
AIR FACTORS:	500 / 410 / 385	SAR 10g:	0.249 W/kg
CONVERSION FACTORS:	0.279 / 0.279 / 0.279	SAR START:	0.182 W/kg
TYPE OF MODULATION:	GSM	SAR END:	0.179 W/kg
MODN. DUTY CYCLE:	12.5%	SAR DRIFT DURING SCAN:	-0.09 dB
DIODE COMPRESSION FACTORS (V*200):	10.9 / 13 / 11.4	PROBE BATTERY LAST CHANGED:	15/11/04
INPUT POWER LEVEL:	5	EXTRAPOLATION:	poly4

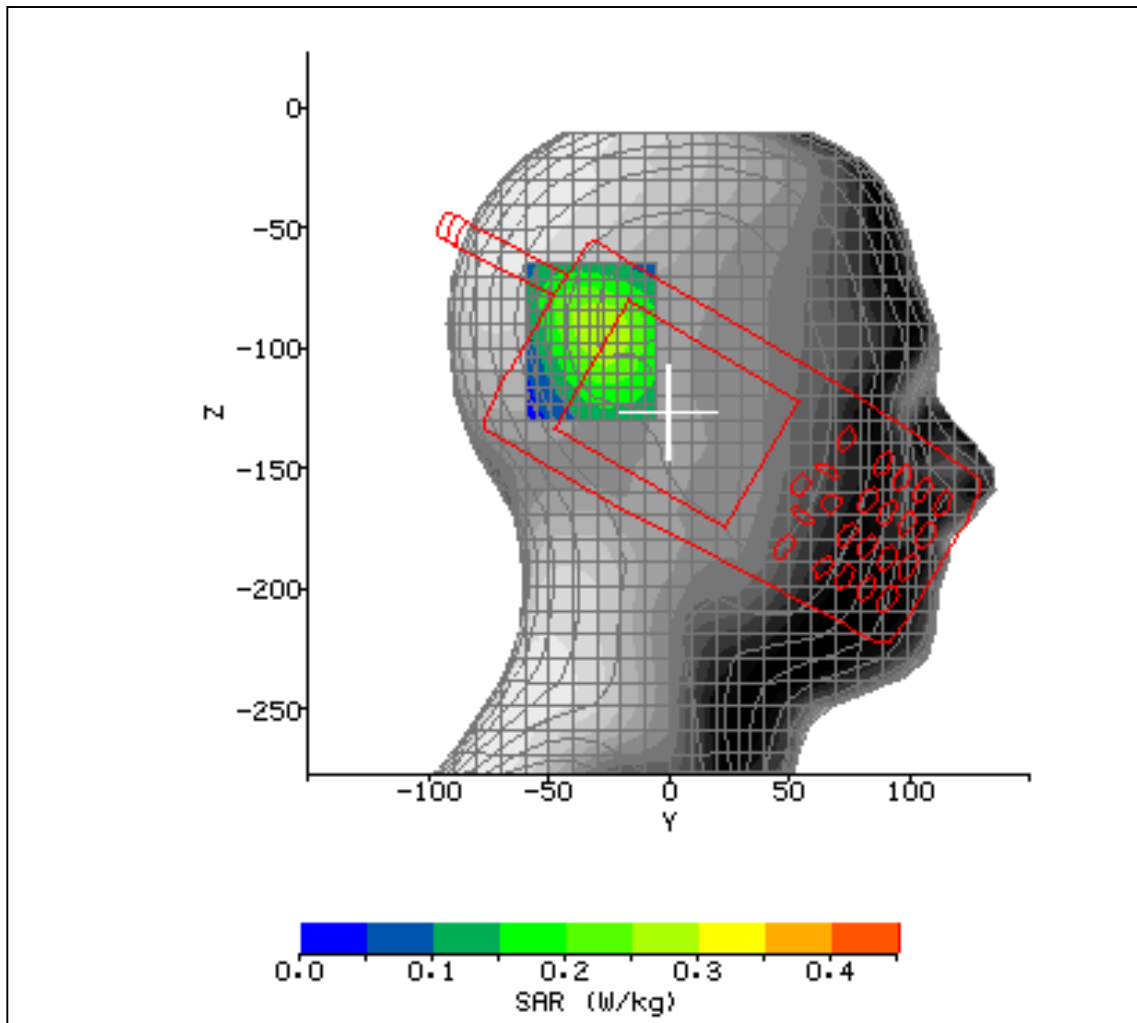

Figure 36



2.8 TEST RESULTS INCLUDING SAR DISTRIBUTIONS (AREA SCANS – 2D)

SYSTEM / SOFTWARE:	SARA2 / 2.3 VPM	INPUT POWER DRIFT:	0.0dBm
DATE / TIME:	19/11/2004 13:48:22	DUT BATTERY MODEL/NO:	318-103-002
FILENAME:	613256_02_007.txt	PROBE SERIAL NUMBER:	084
AMBIENT TEMPERATURE:	23.6°C	LIQUID SIMULANT:	1900 Head
DEVICE UNDER TEST:	Intermec 700 CXL	RELATIVE PERMITTIVITY:	39.76
RELATIVE HUMIDITY:	25.1%	CONDUCTIVITY:	1.418
PHANTOM S/NO:	Head04_36.csv	LIQUID TEMPERATURE:	22.6°C
PHANTOM ROTATION:	30°	MAX SAR Y-AXIS LOCATION:	-62.00 mm
DUT POSITION:	Left Hand Cheek	MAX SAR Z-AXIS LOCATION:	-139.21 mm
ANTENNA CONFIGURATION:	External	MAX E FIELD:	6.86 V/m
TEST FREQUENCY:	1880MHz	SAR 1g:	0.064 W/kg
AIR FACTORS:	500 / 410 / 385	SAR 10g:	0.041 W/kg
CONVERSION FACTORS:	0.354 / 0.354 / 0.354	SAR START:	0.026 W/kg
TYPE OF MODULATION:	GSM	SAR END:	0.026 W/kg
MODN. DUTY CYCLE:	12.5%	SAR DRIFT DURING SCAN:	0.00 dB
DIODE COMPRESSION FACTORS (V*200):	10.9 / 13 / 11.4	PROBE BATTERY LAST CHANGED:	15/11/04
INPUT POWER LEVEL:	0	EXTRAPOLATION:	poly4

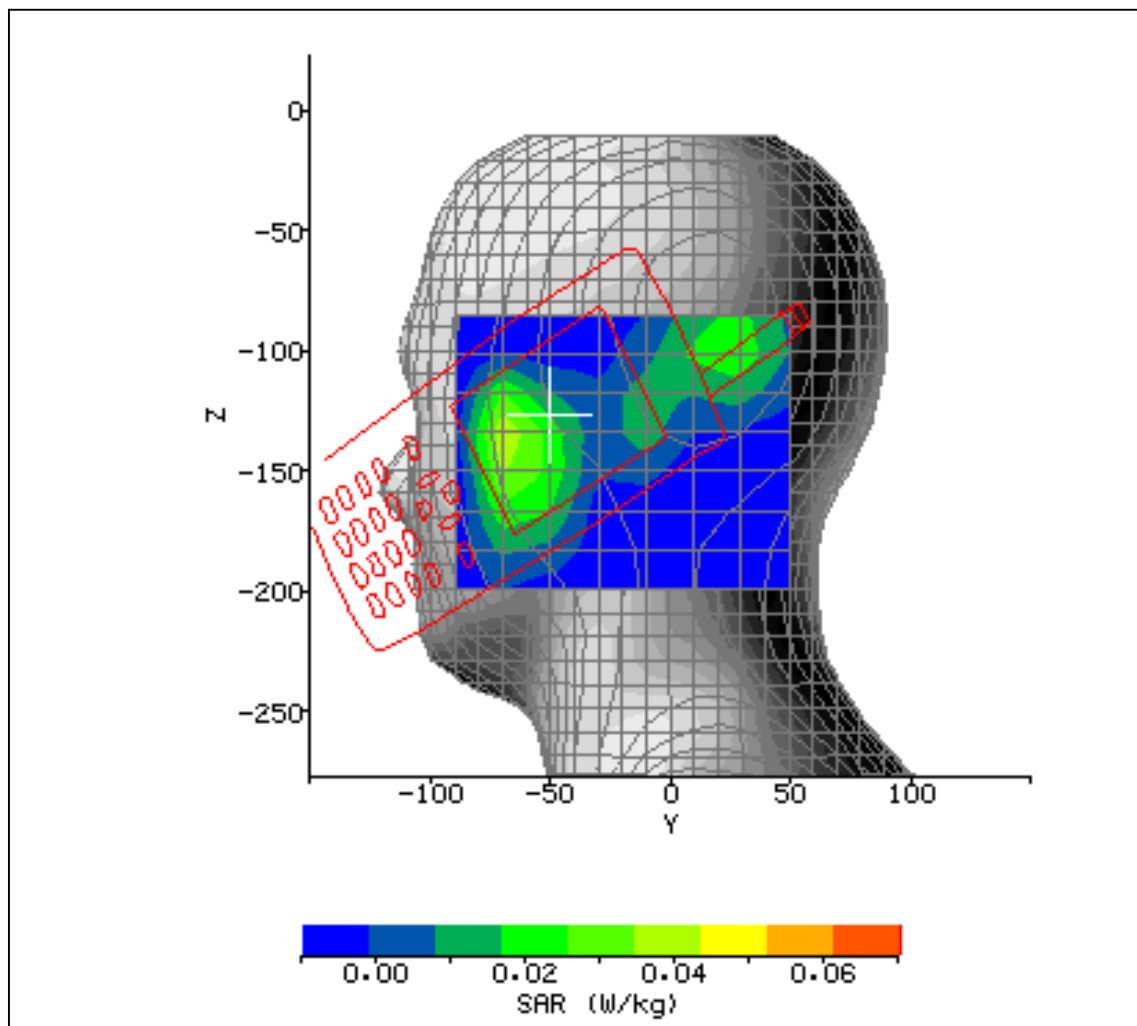

Figure 37



2.8 TEST RESULTS INCLUDING SAR DISTRIBUTIONS (AREA SCANS – 2D)

SYSTEM / SOFTWARE:	SARA2 / 2.3 VPM	INPUT POWER DRIFT:	0.0dBm
DATE / TIME:	19/11/2004 14:32:31	DUT BATTERY MODEL/NO:	318-103-002
FILENAME:	613256_02_008.txt	PROBE SERIAL NUMBER:	084
AMBIENT TEMPERATURE:	24.6°C	LIQUID SIMULANT:	1900 Head
DEVICE UNDER TEST:	Intermec 700 CXL	RELATIVE PERMITTIVITY:	39.76
RELATIVE HUMIDITY:	23%	CONDUCTIVITY:	1.418
PHANTOM S/NO:	Head04_36.csv	LIQUID TEMPERATURE:	22.9°C
PHANTOM ROTATION:	30°	MAX SAR Y-AXIS LOCATION:	28.00 mm
DUT POSITION:	Left Hand 15°	MAX SAR Z-AXIS LOCATION:	-99.79 mm
ANTENNA CONFIGURATION:	External	MAX E FIELD:	8.14 V/m
TEST FREQUENCY:	1880MHz	SAR 1g:	0.082 W/kg
AIR FACTORS:	500 / 410 / 385	SAR 10g:	0.052 W/kg
CONVERSION FACTORS:	0.354 / 0.354 / 0.354	SAR START:	0.033 W/kg
TYPE OF MODULATION:	GSM	SAR END:	0.034 W/kg
MODN. DUTY CYCLE:	12.5%	SAR DRIFT DURING SCAN:	0.07 dB
DIODE COMPRESSION FACTORS (V*200):	10.9 / 13 / 11.4	PROBE BATTERY LAST CHANGED:	15/11/04
INPUT POWER LEVEL:	0	EXTRAPOLATION:	poly4

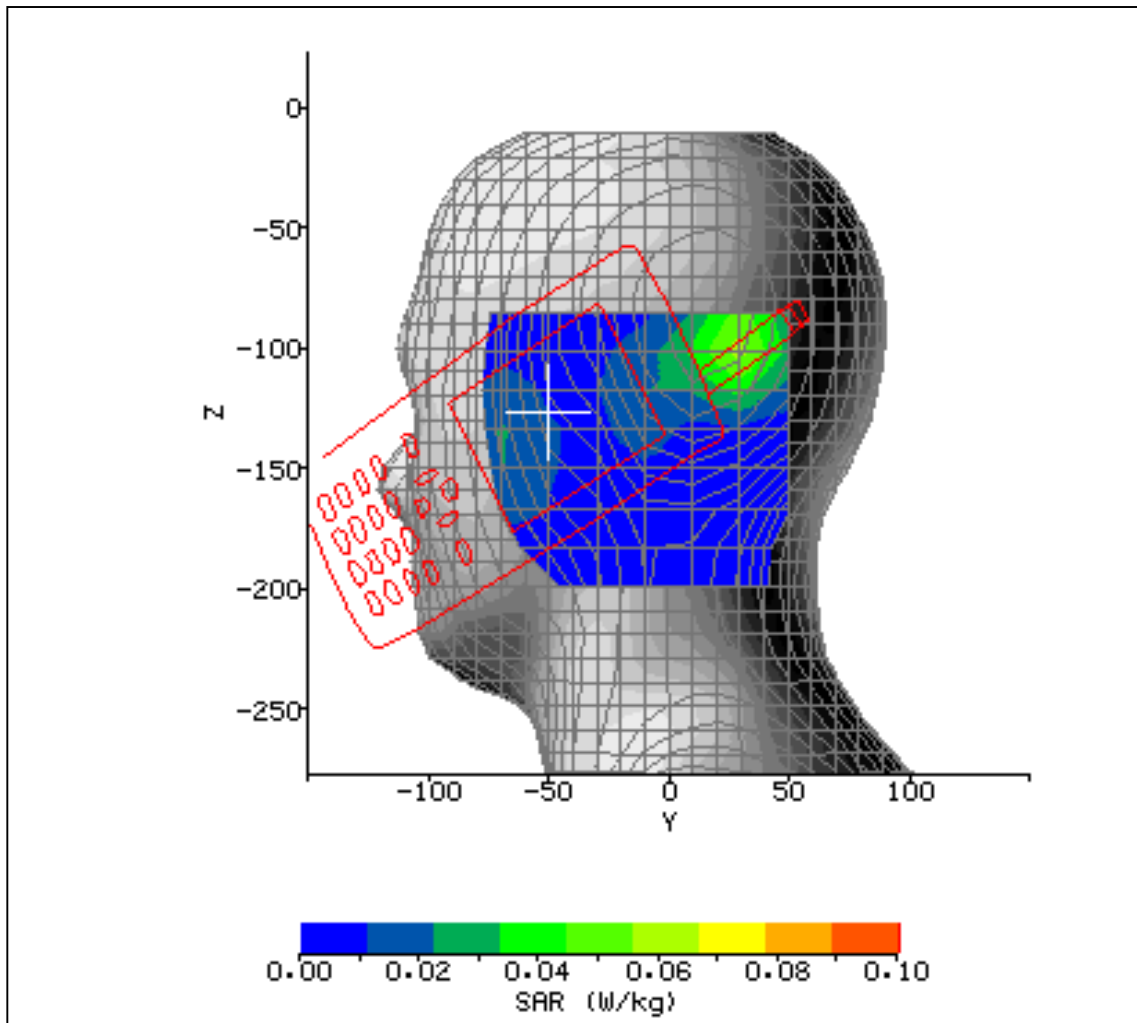

Figure 38



2.8 TEST RESULTS INCLUDING SAR DISTRIBUTIONS (AREA SCANS – 2D)

SYSTEM / SOFTWARE:	SARA2 / 2.3 VPM	INPUT POWER DRIFT:	0.0dBm
DATE / TIME:	19/11/2004 16:36:35	DUT BATTERY MODEL/NO:	318-103-002
FILENAME:	613256_009c.txt	PROBE SERIAL NUMBER:	084
AMBIENT TEMPERATURE:	23.3°C	LIQUID SIMULANT:	1900 Head
DEVICE UNDER TEST:	Intermec 700 CXL	RELATIVE PERMITTIVITY:	39.76
RELATIVE HUMIDITY:	24.2%	CONDUCTIVITY:	1.418
PHANTOM S/NO:	Head04_36.csv	LIQUID TEMPERATURE:	23°C
PHANTOM ROTATION:	210°	MAX SAR Y-AXIS LOCATION:	-74.20 mm
DUT POSITION:	Right Hand Cheek	MAX SAR Z-AXIS LOCATION:	-72.00 mm
ANTENNA CONFIGURATION:	External	MAX E FIELD:	9.60 V/m
TEST FREQUENCY:	1880MHz	SAR 1g:	0.181 W/kg
AIR FACTORS:	500 / 410 / 385	SAR 10g:	0.087 W/kg
CONVERSION FACTORS:	0.354 / 0.354 / 0.354	SAR START:	0.050 W/kg
TYPE OF MODULATION:	GSM	SAR END:	0.051 W/kg
MODN. DUTY CYCLE:	12.5%	SAR DRIFT DURING SCAN:	0.13 dB
DIODE COMPRESSION FACTORS (V*200):	10.9 / 13 / 11.4	PROBE BATTERY LAST CHANGED:	15/11/04
INPUT POWER LEVEL:	0	EXTRAPOLATION:	poly4

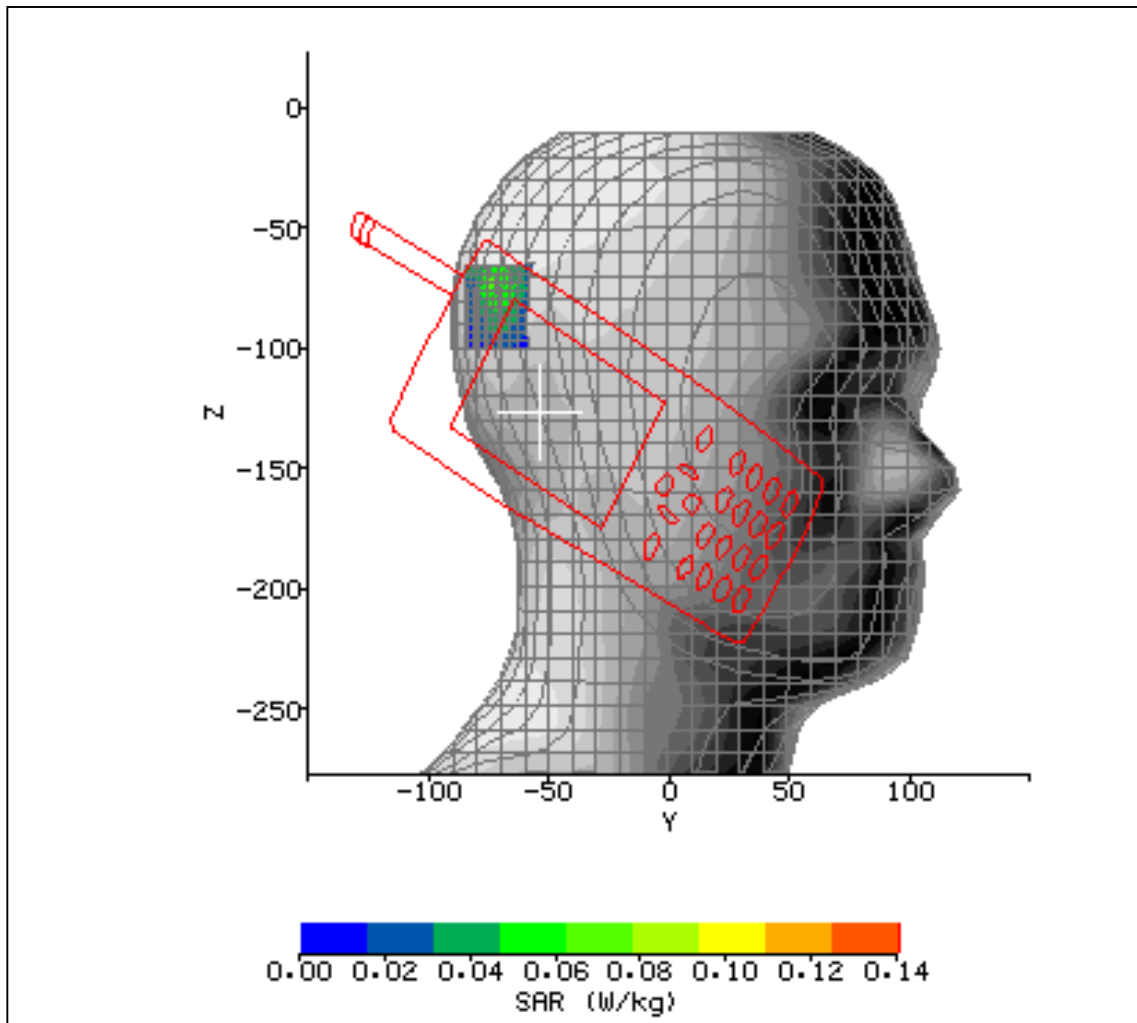

Figure 39



SYSTEM / SOFTWARE:	SARA2 / 2.3 VPM	INPUT POWER DRIFT:	0.0dBm
DATE / TIME:	20/11/2004 09:30:31	DUT BATTERY MODEL/NO:	318-103-002
FILENAME:	613256_02_010b.txt	PROBE SERIAL NUMBER:	084
AMBIENT TEMPERATURE:	23.8°C	LIQUID SIMULANT:	1900 Head
DEVICE UNDER TEST:	Intermec 700 CXL	RELATIVE PERMITTIVITY:	39.76
RELATIVE HUMIDITY:	22.6%	CONDUCTIVITY:	1.418
PHANTOM S/NO:	Head04_36.csv	LIQUID TEMPERATURE:	23.5°C
PHANTOM ROTATION:	210°	MAX SAR Y-AXIS LOCATION:	-72.85 mm
DUT POSITION:	Right Hand 15°	MAX SAR Z-AXIS LOCATION:	-74.80 mm
ANTENNA CONFIGURATION:	External	MAX E FIELD:	12.11 V/m
TEST FREQUENCY:	1880MHz	SAR 1g:	0.209 W/kg
AIR FACTORS:	500 / 410 / 385	SAR 10g:	0.133 W/kg
CONVERSION FACTORS:	0.354 / 0.354 / 0.354	SAR START:	0.142 W/kg
TYPE OF MODULATION:	GSM	SAR END:	0.142 W/kg
MODN. DUTY CYCLE:	12.5%	SAR DRIFT DURING SCAN:	0.00 dB
DIODE COMPRESSION FACTORS (V*200):	10.9 / 13 / 11.4	PROBE BATTERY LAST CHANGED:	15/11/04
INPUT POWER LEVEL:	0	EXTRAPOLATION:	poly4

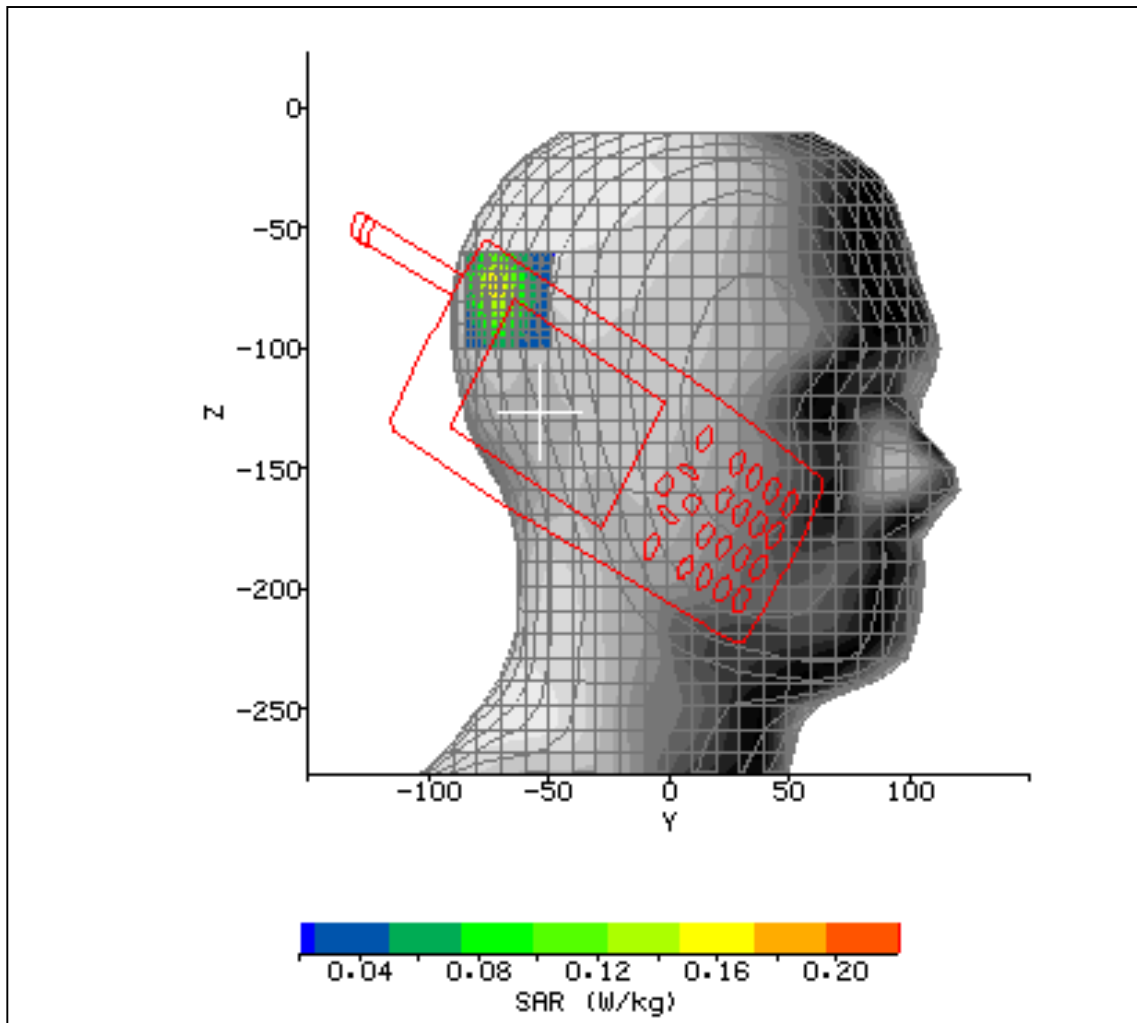

Figure 40



2.8 TEST RESULTS INCLUDING SAR DISTRIBUTIONS (AREA SCANS – 2D)

SYSTEM / SOFTWARE:	SARA2 / 2.3 VPM	INPUT POWER DRIFT:	0.0dBm
DATE / TIME:	20/11/2004 08:29:40	DUT BATTERY MODEL/NO:	318-103-002
FILENAME:	613256_02_011.txt	PROBE SERIAL NUMBER:	084
AMBIENT TEMPERATURE:	24.0°C	LIQUID SIMULANT:	1900 Head
DEVICE UNDER TEST:	Intermec 700 CXL	RELATIVE PERMITTIVITY:	39.76
RELATIVE HUMIDITY:	22.4%	CONDUCTIVITY:	1.418
PHANTOM S/NO:	Head04_36.csv	LIQUID TEMPERATURE:	23.7°C
PHANTOM ROTATION:	210°	MAX SAR Y-AXIS LOCATION:	-72.85 mm
DUT POSITION:	Right Hand 15°	MAX SAR Z-AXIS LOCATION:	-74.00 mm
ANTENNA CONFIGURATION:	External	MAX E FIELD:	12.61 V/m
TEST FREQUENCY:	1850.2MHz	SAR 1g:	0.226 W/kg
AIR FACTORS:	500 / 410 / 385	SAR 10g:	0.146 W/kg
CONVERSION FACTORS:	0.354 / 0.354 / 0.354	SAR START:	0.160 W/kg
TYPE OF MODULATION:	GSM	SAR END:	0.156 W/kg
MODN. DUTY CYCLE:	12.5%	SAR DRIFT DURING SCAN:	-0.11 dB
DIODE COMPRESSION FACTORS (V*200):	10.9 / 13 / 11.4	PROBE BATTERY LAST CHANGED:	15/11/04
INPUT POWER LEVEL:	0	EXTRAPOLATION:	poly4

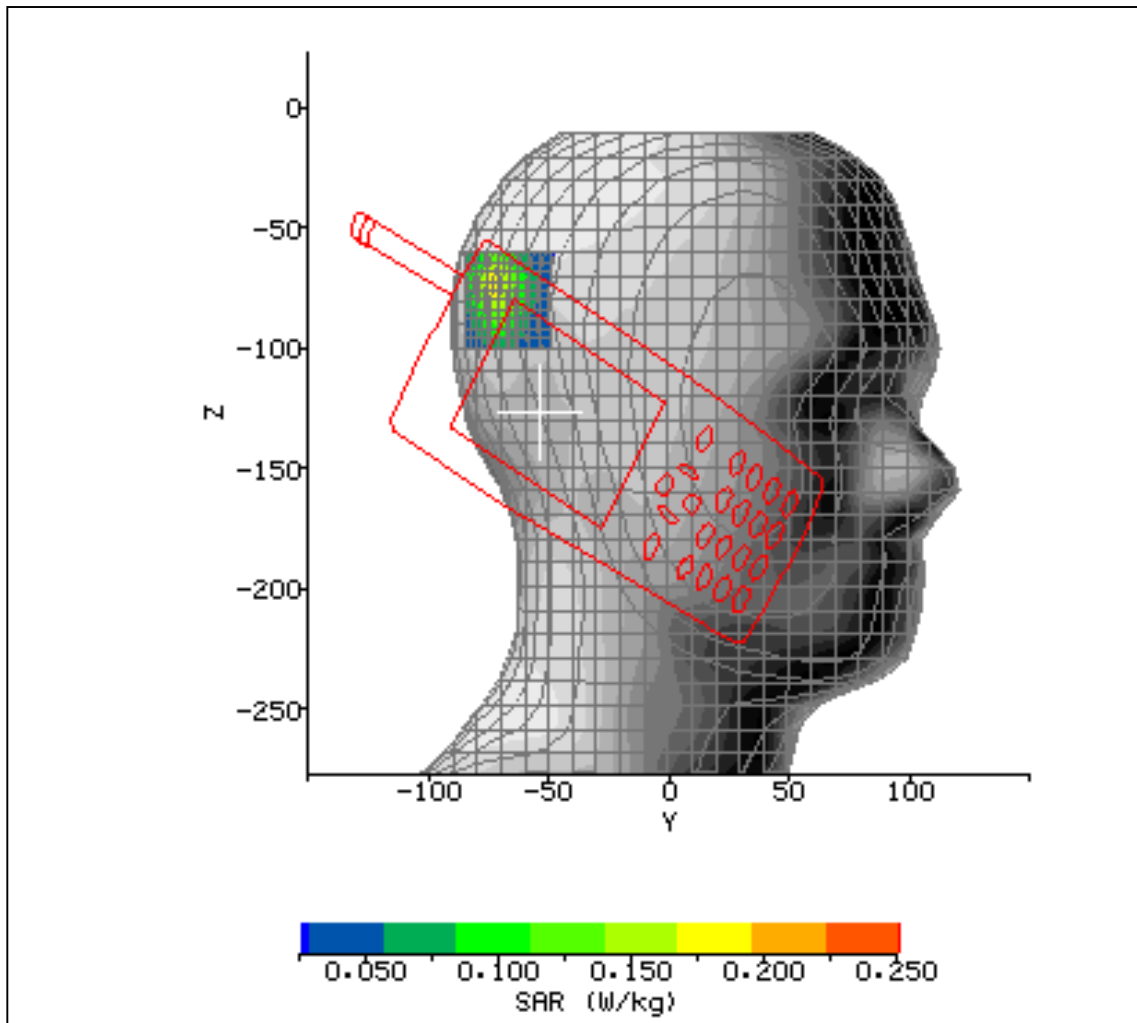

Figure 41



2.8 TEST RESULTS INCLUDING SAR DISTRIBUTIONS (AREA SCANS – 2D)

SYSTEM / SOFTWARE:	SARA2 / 2.3 VPM	INPUT POWER DRIFT:	0.0dBm
DATE / TIME:	20/11/2004 09:02:12	DUT BATTERY MODEL/NO:	318-103-002
FILENAME:	613256_02_012.txt	PROBE SERIAL NUMBER:	084
AMBIENT TEMPERATURE:	23.8°C	LIQUID SIMULANT:	1900 Head
DEVICE UNDER TEST:	Intermec 700 CXL	RELATIVE PERMITTIVITY:	39.76
RELATIVE HUMIDITY:	22.6%	CONDUCTIVITY:	1.418
PHANTOM S/NO:	Head04_36.csv	LIQUID TEMPERATURE:	23.5°C
PHANTOM ROTATION:	210°	MAX SAR Y-AXIS LOCATION:	-72.40 mm
DUT POSITION:	Right Hand 15°	MAX SAR Z-AXIS LOCATION:	-74.40 mm
ANTENNA CONFIGURATION:	External	MAX E FIELD:	12.87 V/m
TEST FREQUENCY:	1909.8MHz	SAR 1g:	0.217 W/kg
AIR FACTORS:	500 / 410 / 385	SAR 10g:	0.146 W/kg
CONVERSION FACTORS:	0.354 / 0.354 / 0.354	SAR START:	0.155 W/kg
TYPE OF MODULATION:	GSM	SAR END:	0.154 W/kg
MODN. DUTY CYCLE:	12.5%	SAR DRIFT DURING SCAN:	-0.03 dB
DIODE COMPRESSION FACTORS (V*200):	10.9 / 13 / 11.4	PROBE BATTERY LAST CHANGED:	15/11/04
INPUT POWER LEVEL:	0	EXTRAPOLATION:	poly4

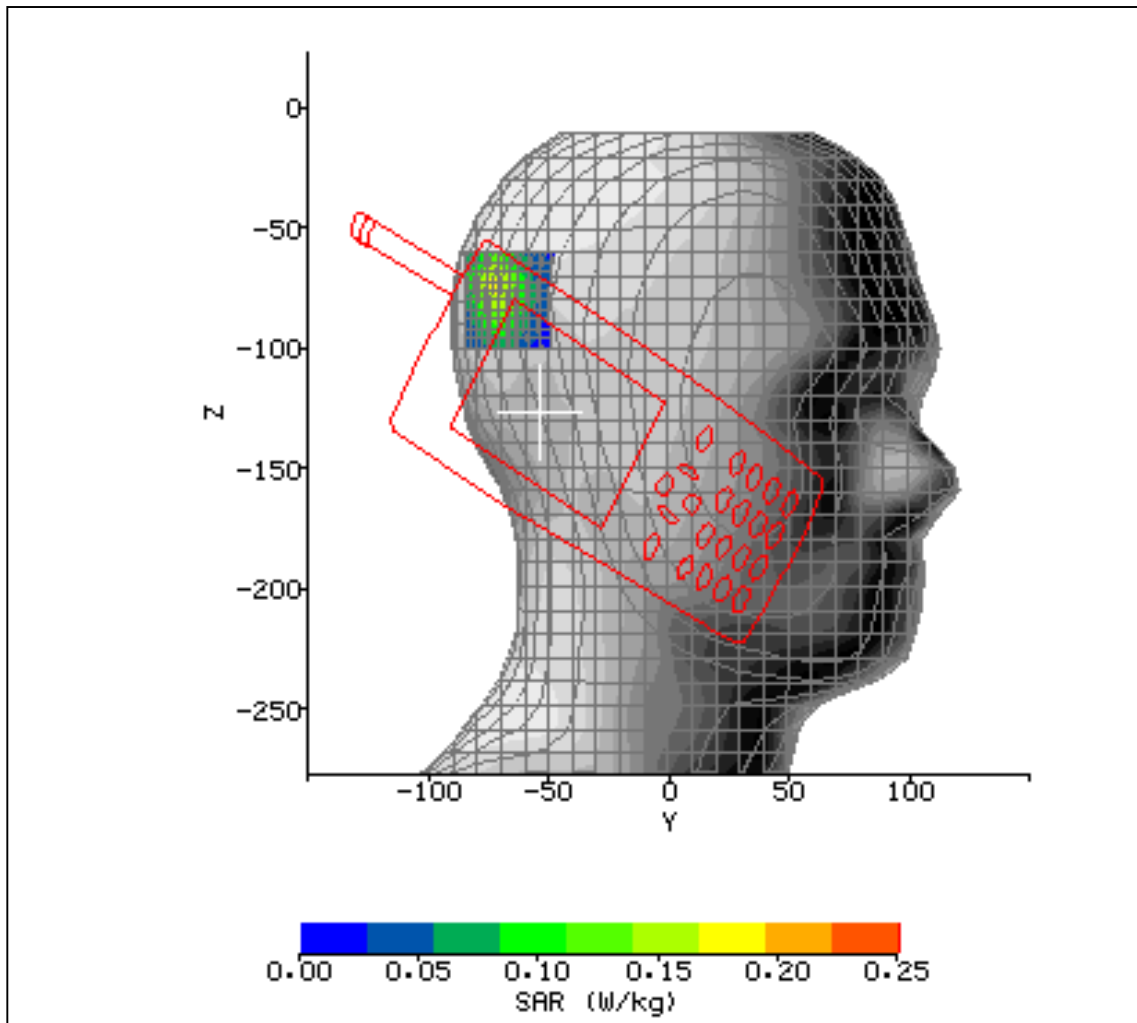

Figure 42



2.8 TEST RESULTS INCLUDING SAR DISTRIBUTIONS (AREA SCANS – 2D)

SYSTEM / SOFTWARE:	SARA2 / 2.3 VPM	INPUT POWER DRIFT:	0.0dBm
DATE / TIME:	22/11/2004 12:15:44	DUT BATTERY MODEL/NO:	318-103-002
FILENAME:	613256_013.txt	PROBE SERIAL NUMBER:	084
AMBIENT TEMPERATURE:	23.4°C	LIQUID SIMULANT:	1900 Body
DEVICE UNDER TEST:	Intermec 700 CXL	RELATIVE PERMITTIVITY:	51.44
RELATIVE HUMIDITY:	42.4%	CONDUCTIVITY:	1.566
PHANTOM S/NO:	HeadBox01.csv	LIQUID TEMPERATURE:	23.6°C
PHANTOM ROTATION:	0°	MAX SAR Y-AXIS LOCATION:	-8.00 mm
DUT POSITION:	Holster 1(Normal) Rear	MAX SAR Z-AXIS LOCATION:	-140.20 mm
ANTENNA CONFIGURATION:	External	MAX E FIELD:	14.87 V/m
TEST FREQUENCY:	1880MHz	SAR 1g:	0.295 W/kg
AIR FACTORS:	500 / 410 / 385	SAR 10g:	0.184 W/kg
CONVERSION FACTORS:	0.405 / 0.405 / 0.405	SAR START:	0.103 W/kg
TYPE OF MODULATION:	GPRS	SAR END:	0.103 W/kg
MODN. DUTY CYCLE:	25%	SAR DRIFT DURING SCAN:	-0.02 dB
DIODE COMPRESSION FACTORS (V*200):	16.1 / 16.1 / 14.7	PROBE BATTERY LAST CHANGED:	22/11/04
INPUT POWER LEVEL:	30dBm	EXTRAPOLATION:	poly4

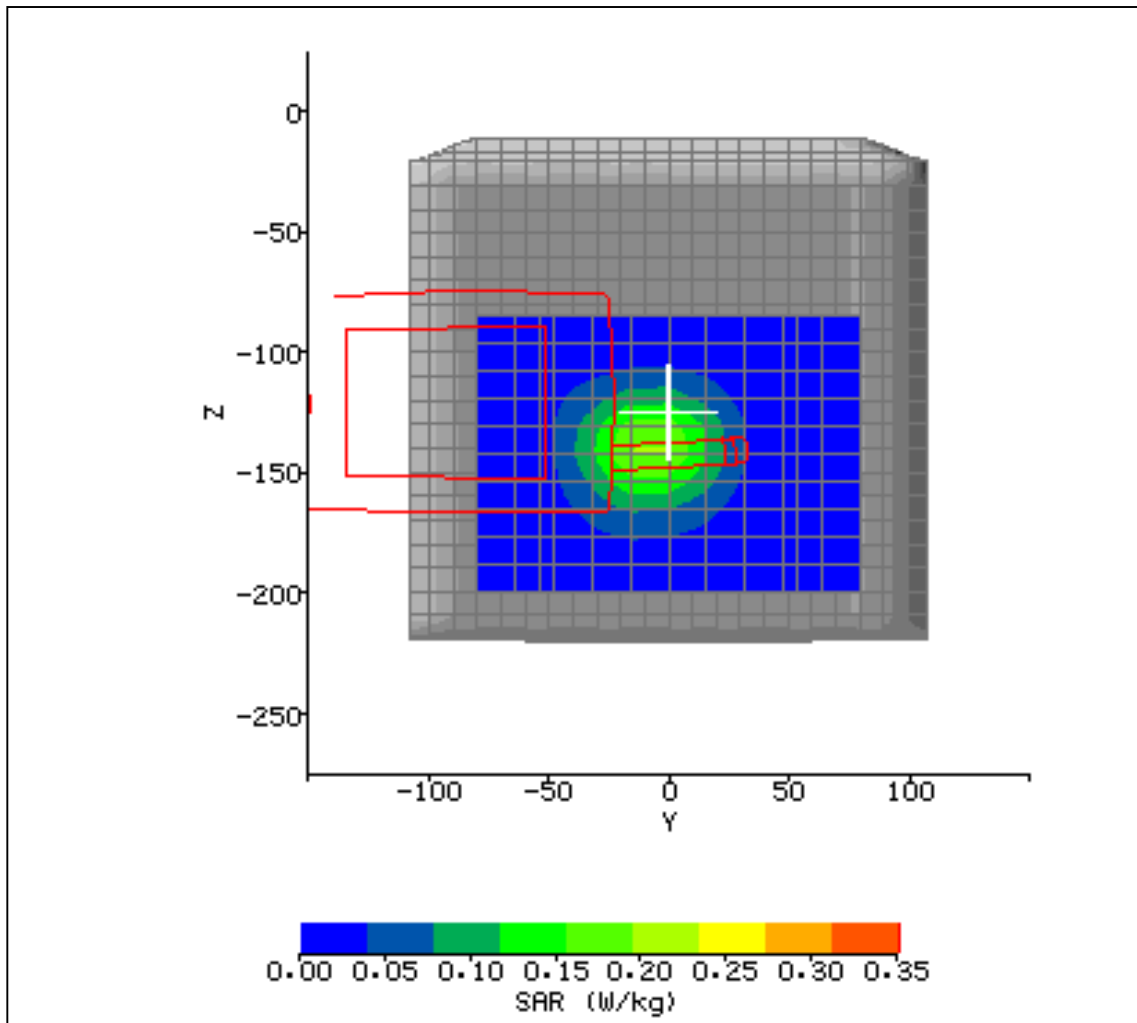

Figure 43



2.8 TEST RESULTS INCLUDING SAR DISTRIBUTIONS (AREA SCANS – 2D)

SYSTEM / SOFTWARE:	SARA2 / 2.3 VPM	INPUT POWER DRIFT:	0.0dBm
DATE / TIME:	22/11/2004 13:37:54	DUT BATTERY MODEL/NO:	318-103-002
FILENAME:	613256_02_014.txt	PROBE SERIAL NUMBER:	084
AMBIENT TEMPERATURE:	23.5°C	LIQUID SIMULANT:	1900 Body
DEVICE UNDER TEST:	Intermec 700 CXL	RELATIVE PERMITTIVITY:	51.44
RELATIVE HUMIDITY:	39.3%	CONDUCTIVITY:	1.566
PHANTOM S/NO:	HeadBox01.csv	LIQUID TEMPERATURE:	23.5°C
PHANTOM ROTATION:	0°	MAX SAR Y-AXIS LOCATION:	-6.40 mm
DUT POSITION:	Holster 1 (Normal) Front	MAX SAR Z-AXIS LOCATION:	-133.30 mm
ANTENNA CONFIGURATION:	External	MAX E FIELD:	15.63 V/m
TEST FREQUENCY:	1880MHz	SAR 1g:	0.325 W/kg
AIR FACTORS:	500 / 410 / 385	SAR 10g:	0.207 W/kg
CONVERSION FACTORS:	0.405 / 0.405 / 0.405	SAR START:	0.115 W/kg
TYPE OF MODULATION:	GPRS	SAR END:	0.115 W/kg
MODN. DUTY CYCLE:	25%	SAR DRIFT DURING SCAN:	-0.03 dB
DIODE COMPRESSION FACTORS (V*200):	16.1 / 16.1 / 14.7	PROBE BATTERY LAST CHANGED:	22/11/04
INPUT POWER LEVEL:	30dBm	EXTRAPOLATION:	poly4

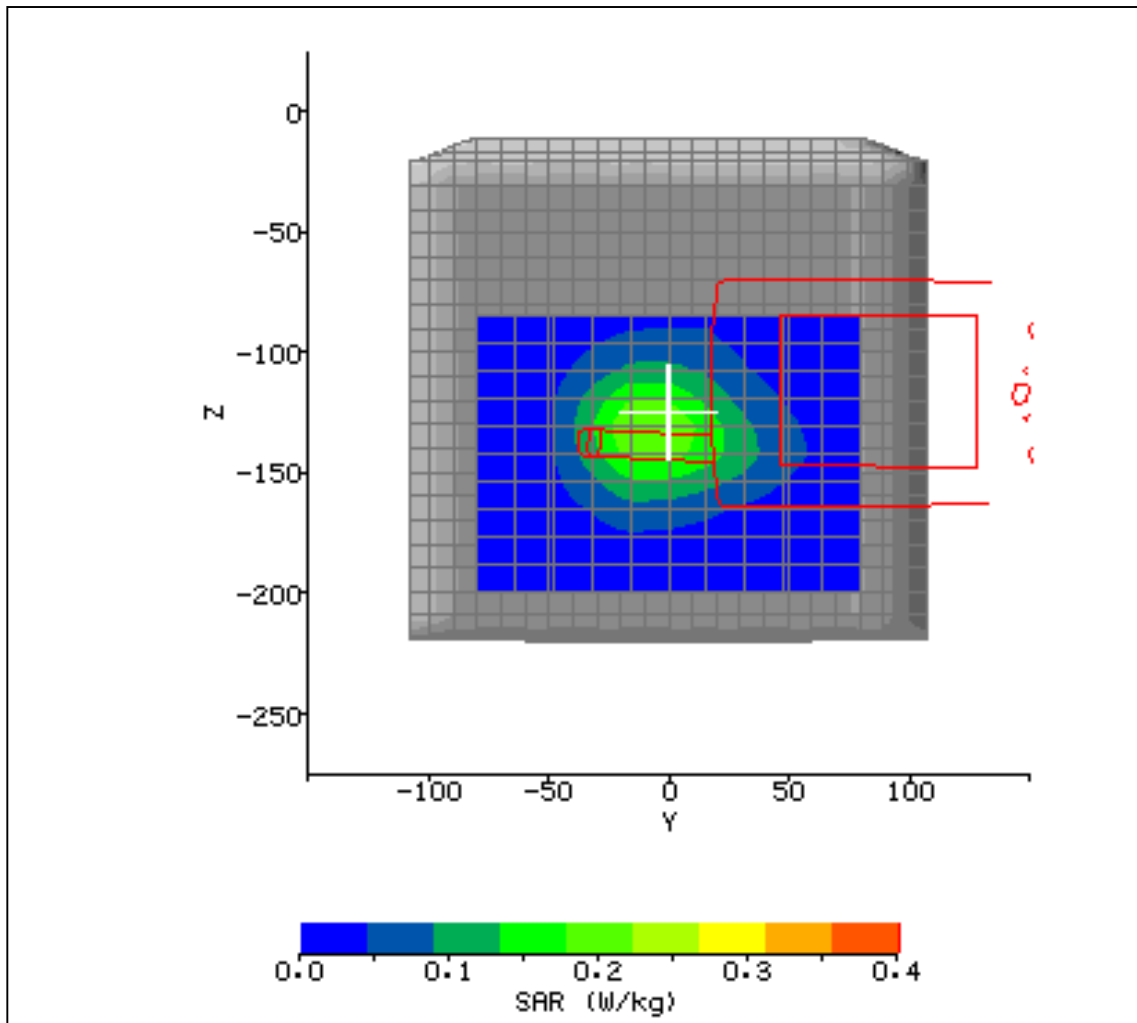

Figure 44



2.8 TEST RESULTS INCLUDING SAR DISTRIBUTIONS (AREA SCANS – 2D)

SYSTEM / SOFTWARE:	SARA2 / 2.3 VPM	INPUT POWER DRIFT:	0.0dBm
DATE / TIME:	22/11/2004 14:27:34	DUT BATTERY MODEL/NO:	318-103-002
FILENAME:	613256_02_015.txt	PROBE SERIAL NUMBER:	084
AMBIENT TEMPERATURE:	23.3°C	LIQUID SIMULANT:	1900 Body
DEVICE UNDER TEST:	Intermec 700 CXL	RELATIVE PERMITTIVITY:	51.44
RELATIVE HUMIDITY:	41.8%	CONDUCTIVITY:	1.566
PHANTOM S/NO:	HeadBox01.csv	LIQUID TEMPERATURE:	23.5°C
PHANTOM ROTATION:	0°	MAX SAR Y-AXIS LOCATION:	-8.00 mm
DUT POSITION:	Holster 1 (Normal)Front	MAX SAR Z-AXIS LOCATION:	-133.30 mm
ANTENNA CONFIGURATION:	External	MAX E FIELD:	17.15 V/m
TEST FREQUENCY:	1850.2MHz	SAR 1g:	0.393 W/kg
AIR FACTORS:	500 / 410 / 385	SAR 10g:	0.250 W/kg
CONVERSION FACTORS:	0.405 / 0.405 / 0.405	SAR START:	0.141 W/kg
TYPE OF MODULATION:	GPRS	SAR END:	0.141 W/kg
MODN. DUTY CYCLE:	25%	SAR DRIFT DURING SCAN:	-0.01 dB
DIODE COMPRESSION FACTORS (V*200):	16.1 / 16.1 / 14.7	PROBE BATTERY LAST CHANGED:	22/11/04
INPUT POWER LEVEL:	30dBm	EXTRAPOLATION:	poly4

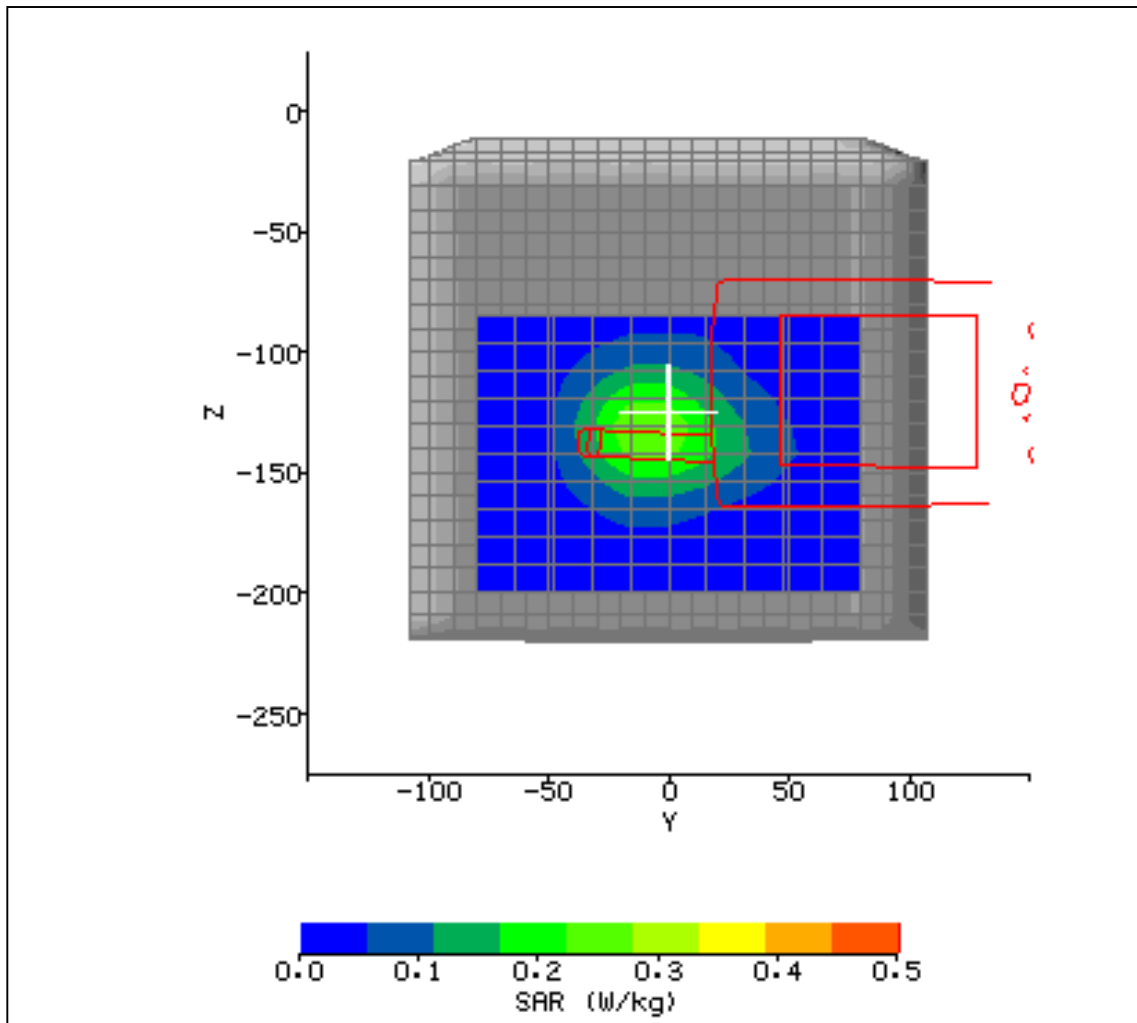

Figure 45



2.8 TEST RESULTS INCLUDING SAR DISTRIBUTIONS (AREA SCANS – 2D)

SYSTEM / SOFTWARE:	SARA2 / 2.3 VPM	INPUT POWER DRIFT:	0.0dBm
DATE / TIME:	22/11/2004 15:15:40	DUT BATTERY MODEL/NO:	318-103-002
FILENAME:	613256_02_016.txt	PROBE SERIAL NUMBER:	084
AMBIENT TEMPERATURE:	23.3°C	LIQUID SIMULANT:	1900 Body
DEVICE UNDER TEST:	Intermec 700 CXL	RELATIVE PERMITTIVITY:	51.44
RELATIVE HUMIDITY:	42.9%	CONDUCTIVITY:	1.566
PHANTOM S/NO:	HeadBox01.csv	LIQUID TEMPERATURE:	23.4°C
PHANTOM ROTATION:	0°	MAX SAR Y-AXIS LOCATION:	-4.80 mm
DUT POSITION:	Holster 1 (Normal) Front	MAX SAR Z-AXIS LOCATION:	-133.30 mm
ANTENNA CONFIGURATION:	External	MAX E FIELD:	16.05 V/m
TEST FREQUENCY:	1909.8MHz	SAR 1g:	0.348 W/kg
AIR FACTORS:	500 / 410 / 385	SAR 10g:	0.220 W/kg
CONVERSION FACTORS:	0.405 / 0.405 / 0.405	SAR START:	0.118 W/kg
TYPE OF MODULATION:	GPRS	SAR END:	0.119 W/kg
MODN. DUTY CYCLE:	25%	SAR DRIFT DURING SCAN:	0.04 dB
DIODE COMPRESSION FACTORS (V*200):	16.1 / 16.1 / 14.7	PROBE BATTERY LAST CHANGED:	22/11/04
INPUT POWER LEVEL:	30dBm	EXTRAPOLATION:	poly4

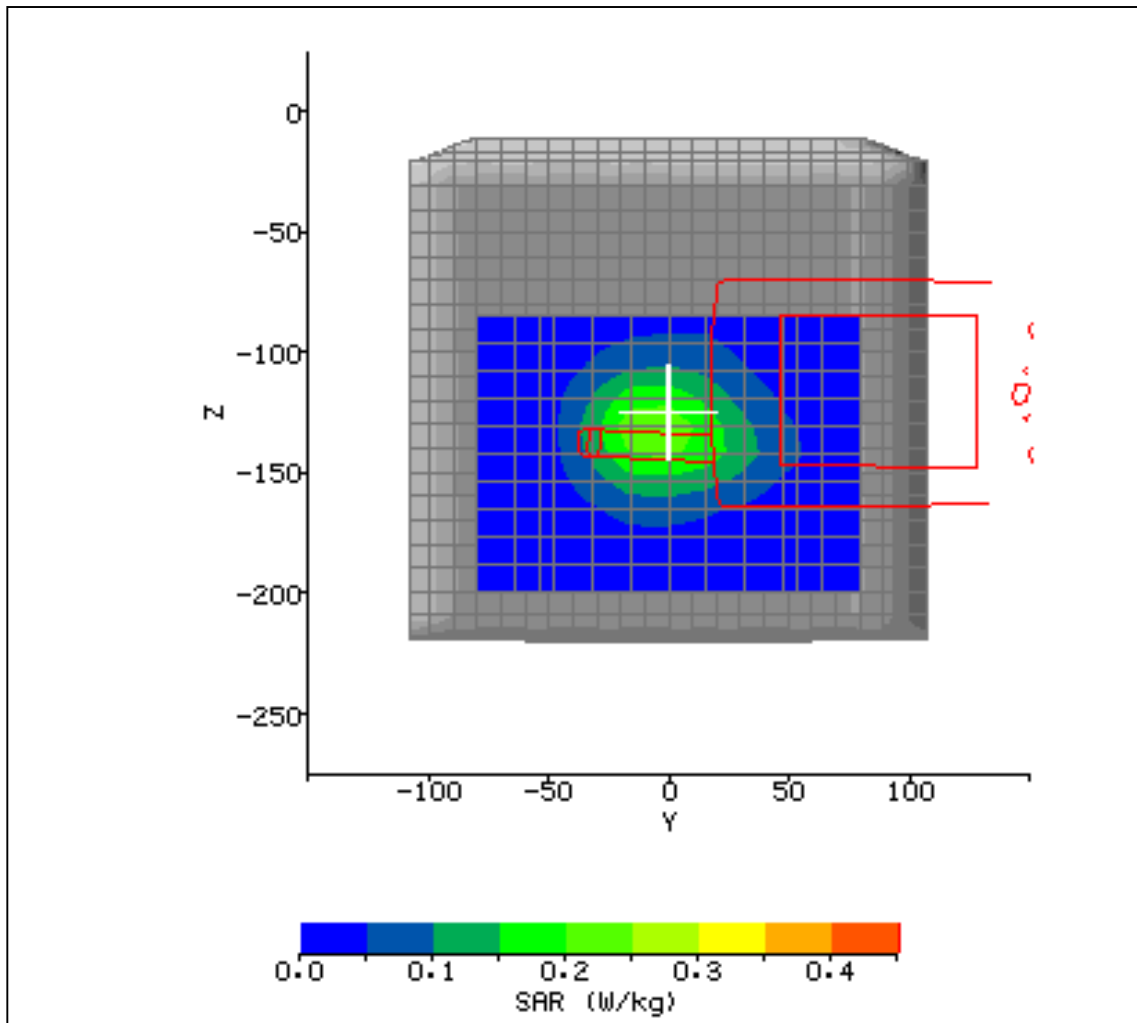

Figure 46



2.8 TEST RESULTS INCLUDING SAR DISTRIBUTIONS (AREA SCANS – 2D)

SYSTEM / SOFTWARE:	SARA2 / 2.3 VPM	INPUT POWER DRIFT:	0.3dBm
DATE / TIME:	23/11/2004 11:53:40	DUT BATTERY MODEL/NO:	318-103-002
FILENAME:	613256_02_018.txt	PROBE SERIAL NUMBER:	084
AMBIENT TEMPERATURE:	24.3°C	LIQUID SIMULANT:	1900 Body
DEVICE UNDER TEST:	Intermec 700 CXL	RELATIVE PERMITTIVITY:	51.44
RELATIVE HUMIDITY:	39%	CONDUCTIVITY:	1.566
PHANTOM S/NO:	HeadBox01.csv	LIQUID TEMPERATURE:	23.4°C
PHANTOM ROTATION:	0°	MAX SAR Y-AXIS LOCATION:	-17.60 mm
DUT POSITION:	Holster 2 (Normal) Front	MAX SAR Z-AXIS LOCATION:	-156.30 mm
ANTENNA CONFIGURATION:	External	MAX E FIELD:	10.40 V/m
TEST FREQUENCY:	1850.2MHz	SAR 1g:	0.146 W/kg
AIR FACTORS:	500 / 410 / 385	SAR 10g:	0.096 W/kg
CONVERSION FACTORS:	0.405 / 0.405 / 0.405	SAR START:	0.051 W/kg
TYPE OF MODULATION:	GPRS	SAR END:	0.050 W/kg
MODN. DUTY CYCLE:	12.5%	SAR DRIFT DURING SCAN:	-0.11 dB
DIODE COMPRESSION FACTORS (V*200):	16.1 / 16.1 / 14.7	PROBE BATTERY LAST CHANGED:	22/11/04
INPUT POWER LEVEL:	30dBm	EXTRAPOLATION:	poly4

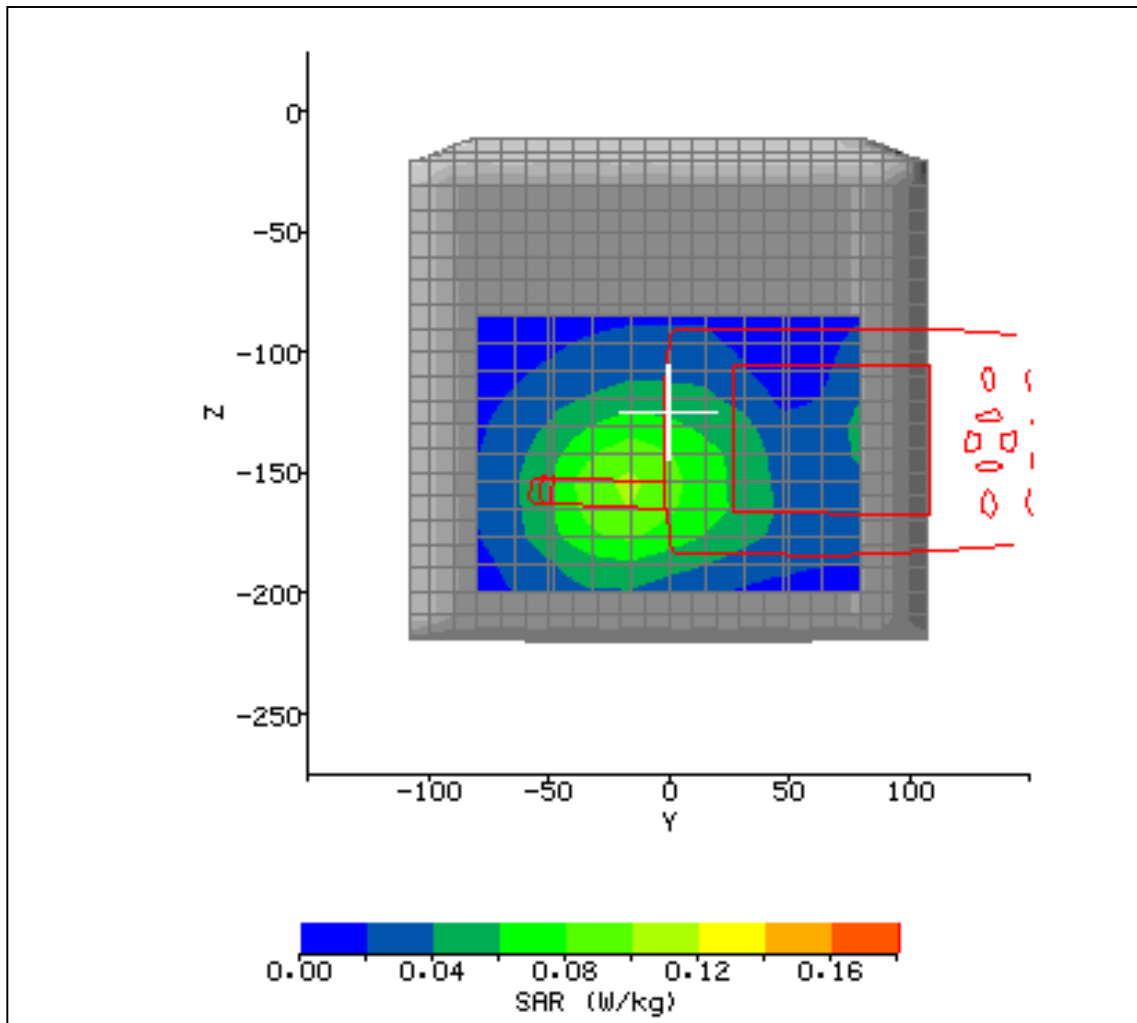

Figure 47



2.8 TEST RESULTS INCLUDING SAR DISTRIBUTIONS (AREA SCANS – 2D)

SYSTEM / SOFTWARE:	SARA2 / 2.3 VPM	INPUT POWER DRIFT:	0.0dBm
DATE / TIME:	23/11/2004 12:59:22	DUT BATTERY MODEL/NO:	318-103-002
FILENAME:	613256_02_019.txt	PROBE SERIAL NUMBER:	084
AMBIENT TEMPERATURE:	25°C	LIQUID SIMULANT:	1900 Body
DEVICE UNDER TEST:	Intermec 700 CXL	RELATIVE PERMITTIVITY:	51.44
RELATIVE HUMIDITY:	34.1%	CONDUCTIVITY:	1.566
PHANTOM S/NO:	HeadBox01.csv	LIQUID TEMPERATURE:	23.6°C
PHANTOM ROTATION:	0°	MAX SAR Y-AXIS LOCATION:	19.20 mm
DUT POSITION:	Holster 2 (inverted) Rear	MAX SAR Z-AXIS LOCATION:	-164.35 mm
ANTENNA CONFIGURATION:	External	MAX E FIELD:	12.56 V/m
TEST FREQUENCY:	1850.2MHz	SAR 1g:	0.213 W/kg
AIR FACTORS:	500 / 410 / 385	SAR 10g:	0.138 W/kg
CONVERSION FACTORS:	0.405 / 0.405 / 0.405	SAR START:	0.079 W/kg
TYPE OF MODULATION:	GPRS	SAR END:	0.079 W/kg
MODN. DUTY CYCLE:	25%	SAR DRIFT DURING SCAN:	0.00 dB
DIODE COMPRESSION FACTORS (V*200):	16.1 / 16.1 / 14.7	PROBE BATTERY LAST CHANGED:	22/11/04
INPUT POWER LEVEL:	30dBm	EXTRAPOLATION:	poly4

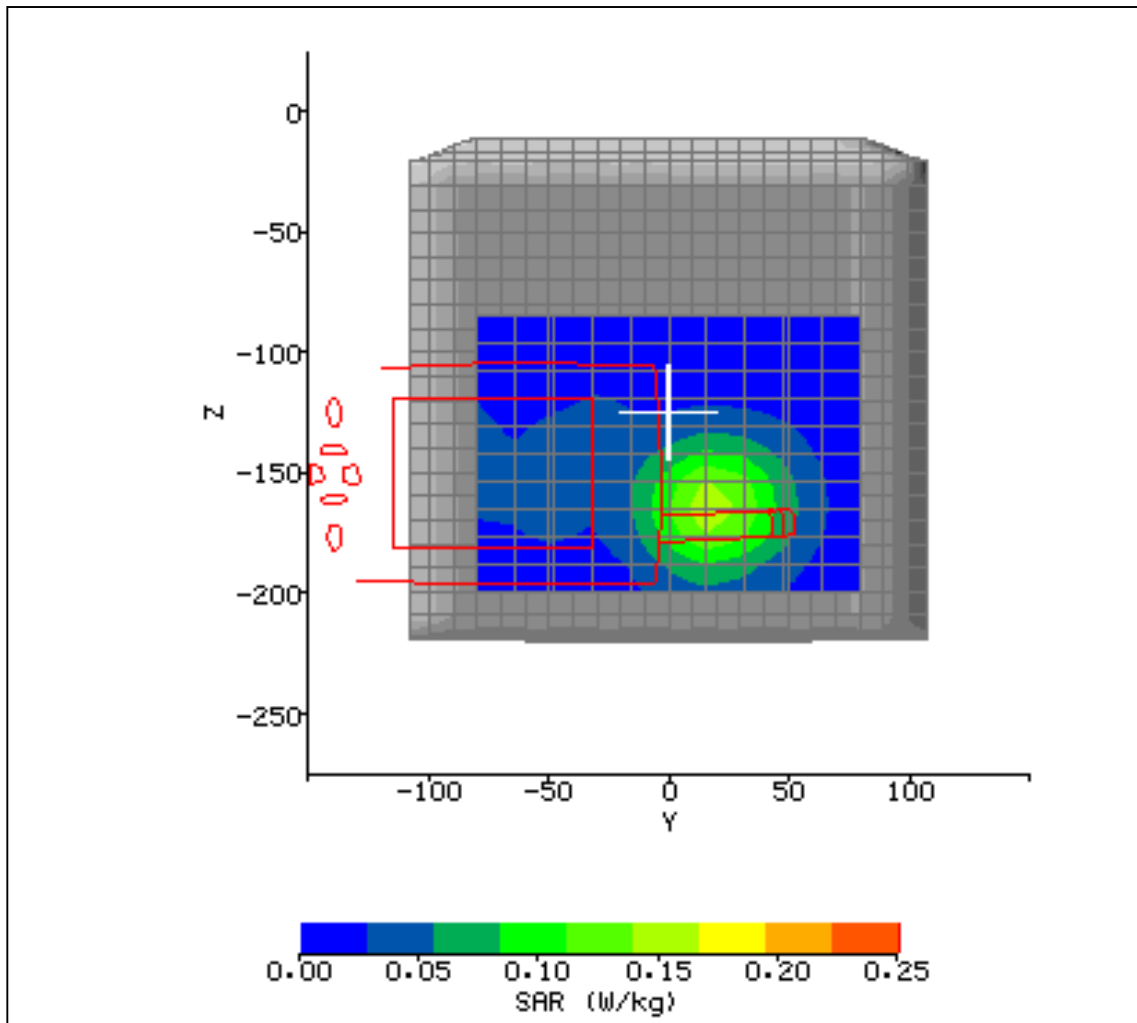

Figure 48



2.8 TEST RESULTS INCLUDING SAR DISTRIBUTIONS (AREA SCANS – 2D)

SYSTEM / SOFTWARE:	SARA2 / 2.3 VPM	INPUT POWER DRIFT:	0.0dBm
DATE / TIME:	23/11/2004 14:45:00	DUT BATTERY MODEL/NO:	318-103-002
FILENAME:	613256_02_020.txt	PROBE SERIAL NUMBER:	084
AMBIENT TEMPERATURE:	25.5°C	LIQUID SIMULANT:	1900 Body
DEVICE UNDER TEST:	Intermec 700 CXL	RELATIVE PERMITTIVITY:	51.44
RELATIVE HUMIDITY:	33.7%	CONDUCTIVITY:	1.566
PHANTOM S/NO:	HeadBox01.csv	LIQUID TEMPERATURE:	23.6°C
PHANTOM ROTATION:	0°	MAX SAR Y-AXIS LOCATION:	-14.40 mm
DUT POSITION:	Holster 2 (Normal side)	MAX SAR Z-AXIS LOCATION:	-133.30 mm
ANTENNA CONFIGURATION:	External	MAX E FIELD:	12.01 V/m
TEST FREQUENCY:	1850.2MHz	SAR 1g:	0.195 W/kg
AIR FACTORS:	500 / 410 / 385	SAR 10g:	0.127 W/kg
CONVERSION FACTORS:	0.405 / 0.405 / 0.405	SAR START:	0.068 W/kg
TYPE OF MODULATION:	GPRS	SAR END:	0.068 W/kg
MODN. DUTY CYCLE:	25%	SAR DRIFT DURING SCAN:	-0.02 dB
DIODE COMPRESSION FACTORS (V*200):	16.1 / 16.1 / 14.7	PROBE BATTERY LAST CHANGED:	22/11/04
INPUT POWER LEVEL:	30dBm	EXTRAPOLATION:	poly4

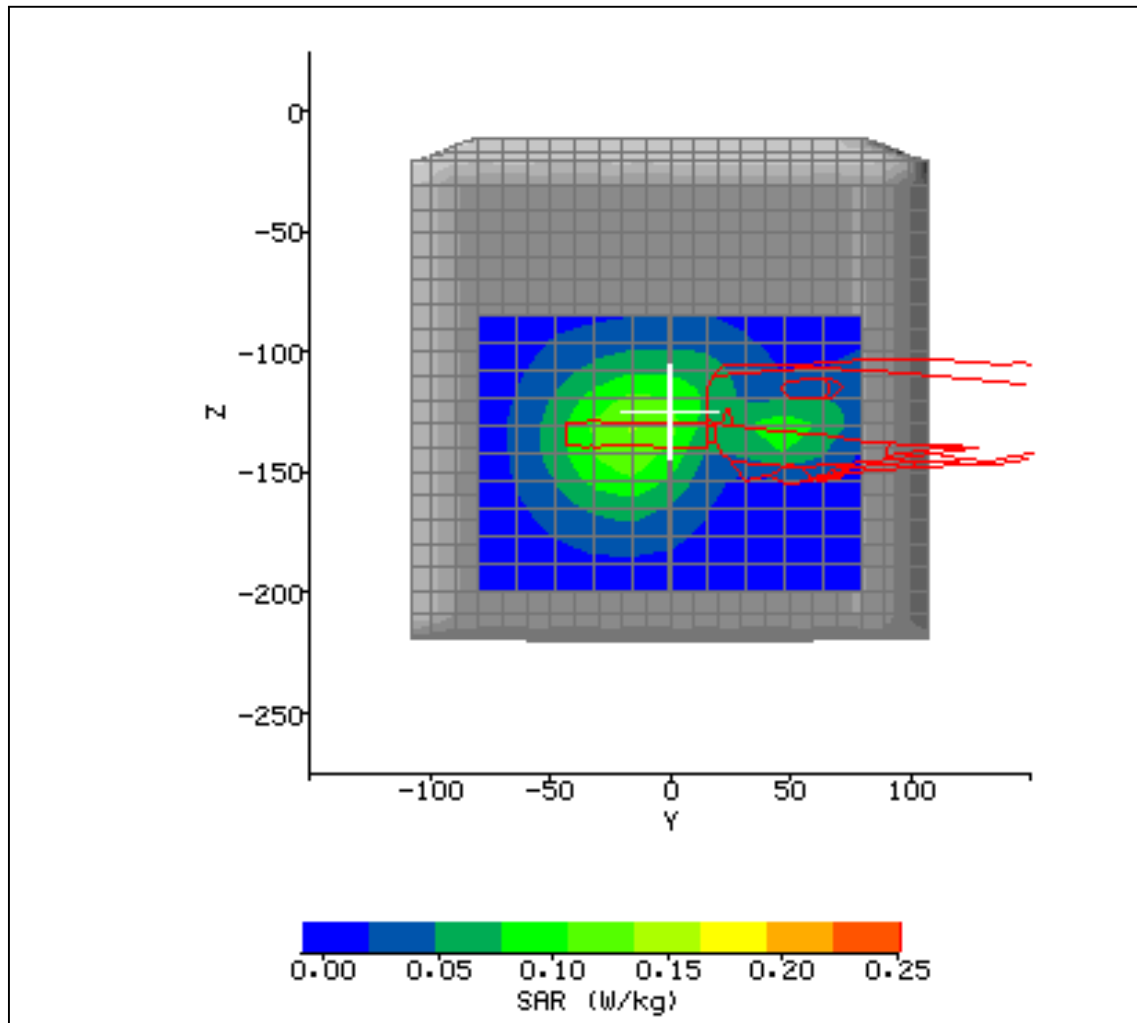

Figure 49



2.8 TEST RESULTS INCLUDING SAR DISTRIBUTIONS (AREA SCANS – 2D)

SYSTEM / SOFTWARE:	SARA2 / 2.3 VPM	INPUT POWER DRIFT:	0.0dBm
DATE / TIME:	23/11/2004 15:40:46	DUT BATTERY MODEL/NO:	318-103-002
FILENAME:	613256_02_021.txt	PROBE SERIAL NUMBER:	084
AMBIENT TEMPERATURE:	24.2°C	LIQUID SIMULANT:	1900 Body
DEVICE UNDER TEST:	Intermec 700 CXL	RELATIVE PERMITTIVITY:	51.44
RELATIVE HUMIDITY:	37%	CONDUCTIVITY:	1.566
PHANTOM S/NO:	HeadBox01.csv	LIQUID TEMPERATURE:	23.2°C
PHANTOM ROTATION:	0°	MAX SAR Y-AXIS LOCATION:	30.40 mm
DUT POSITION:	Holster 2 (Inverted side)	MAX SAR Z-AXIS LOCATION:	-152.85 mm
ANTENNA CONFIGURATION:	External	MAX E FIELD:	11.42 V/m
TEST FREQUENCY:	1850.2MHz	SAR 1g:	0.177 W/kg
AIR FACTORS:	500 / 410 / 385	SAR 10g:	0.115 W/kg
CONVERSION FACTORS:	0.405 / 0.405 / 0.405	SAR START:	0.062 W/kg
TYPE OF MODULATION:	GPRS	SAR END:	0.063 W/kg
MODN. DUTY CYCLE:	25%	SAR DRIFT DURING SCAN:	0.11 dB
DIODE COMPRESSION FACTORS (V*200):	16.1 / 16.1 / 14.7	PROBE BATTERY LAST CHANGED:	22/11/04
INPUT POWER LEVEL:	30dBm	EXTRAPOLATION:	poly4

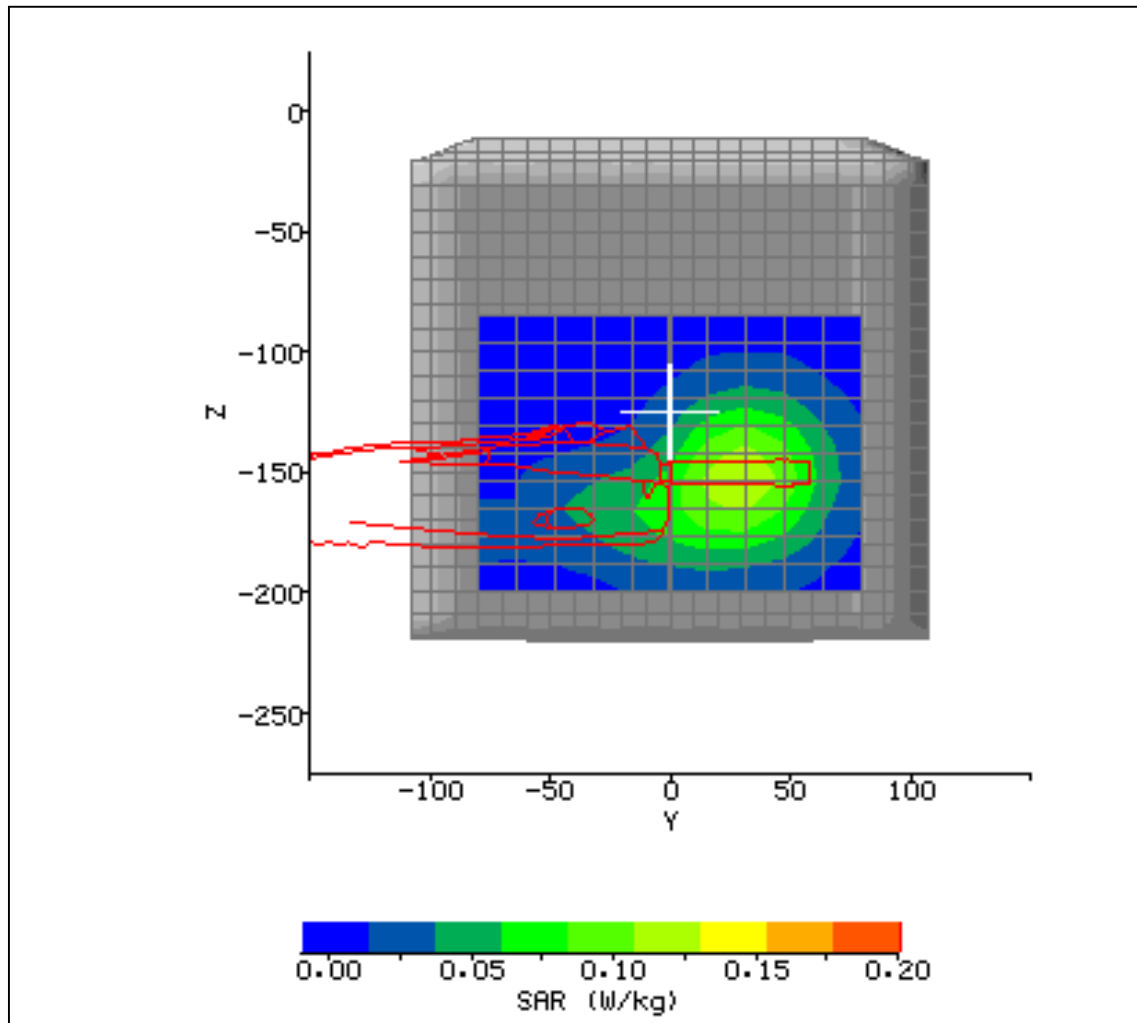

Figure 50



2.8 TEST RESULTS INCLUDING SAR DISTRIBUTIONS (AREA SCANS – 2D)

SYSTEM / SOFTWARE:	SARA2 / 2.3 VPM	INPUT POWER DRIFT:	0.0dBm
DATE / TIME:	23/11/2004 17:19:26	DUT BATTERY MODEL/NO:	318-103-002
FILENAME:	613256_02_022.txt	PROBE SERIAL NUMBER:	084
AMBIENT TEMPERATURE:	23.5°C	LIQUID SIMULANT:	835/900 Body
DEVICE UNDER TEST:	Intermec 700 CXL	RELATIVE PERMITTIVITY:	58.12
RELATIVE HUMIDITY:	38.9%	CONDUCTIVITY:	0.991
PHANTOM S/NO:	HeadBox02.csv	LIQUID TEMPERATURE:	22.5°C
PHANTOM ROTATION:	0°	MAX SAR Y-AXIS LOCATION:	3.20 mm
DUT POSITION:	Holster 1 (Inverted) Rear	MAX SAR Z-AXIS LOCATION:	-132.15 mm
ANTENNA CONFIGURATION:	External	MAX E FIELD:	20.06 V/m
TEST FREQUENCY:	836.4MHz	SAR 1g:	0.360 W/kg
AIR FACTORS:	500 / 410 / 385	SAR 10g:	0.261 W/kg
CONVERSION FACTORS:	0.3 / 0.3 / 0.3	SAR START:	0.183 W/kg
TYPE OF MODULATION:	GPRS	SAR END:	0.178 W/kg
MODN. DUTY CYCLE:	25%	SAR DRIFT DURING SCAN:	-0.12 dB
DIODE COMPRESSION FACTORS (V*200):	16.1 / 16.1 / 14.7	PROBE BATTERY LAST CHANGED:	22/11/04
INPUT POWER LEVEL:	33dBm	EXTRAPOLATION:	poly4

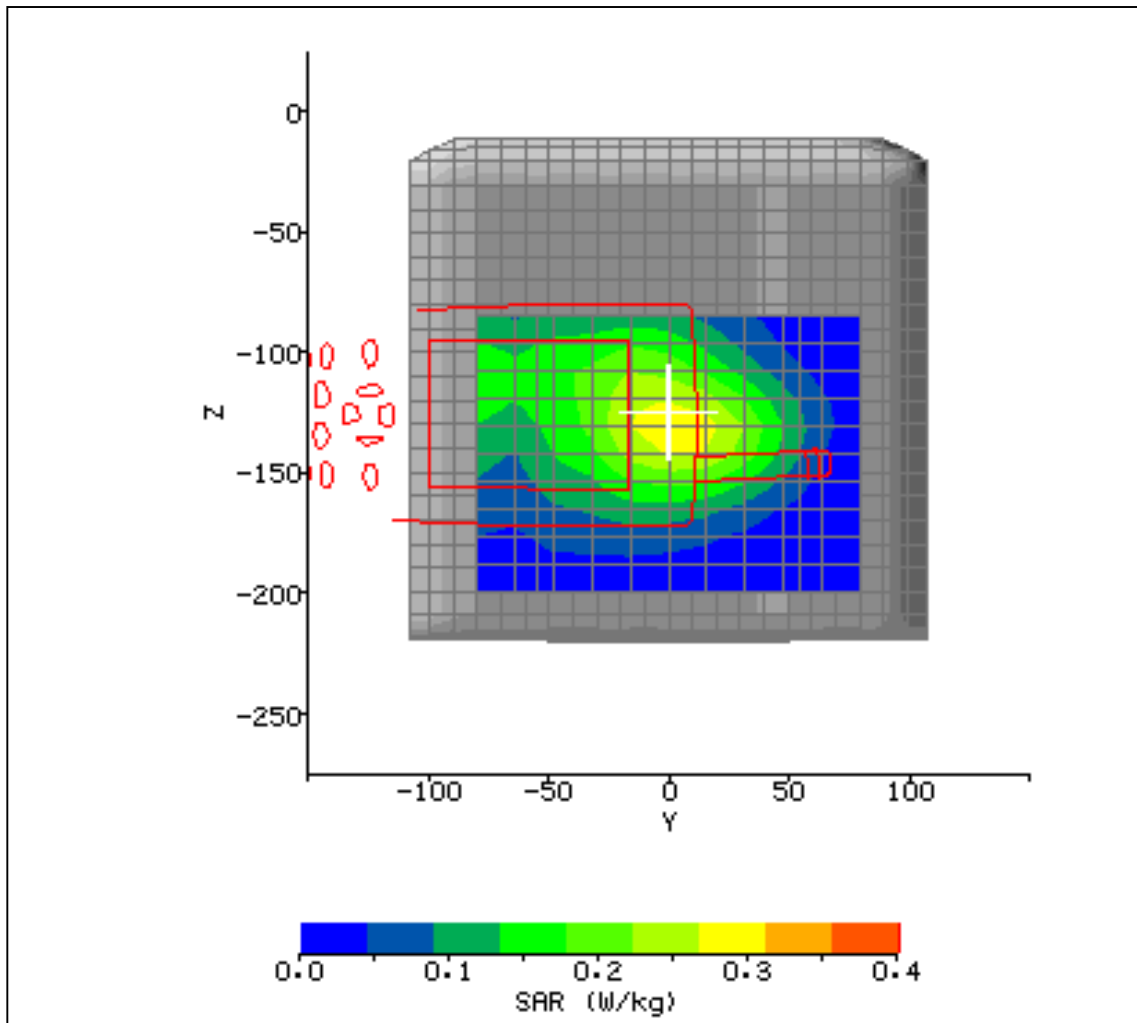

Figure 51



2.8 TEST RESULTS INCLUDING SAR DISTRIBUTIONS (AREA SCANS – 2D)

SYSTEM / SOFTWARE:	SARA2 / 2.3 VPM	INPUT POWER DRIFT:	0.5dBm
DATE / TIME:	24/11/2004 09:02:16	DUT BATTERY MODEL/NO:	318-103-002
FILENAME:	613256_02_023.txt	PROBE SERIAL NUMBER:	084
AMBIENT TEMPERATURE:	24.9°C	LIQUID SIMULANT:	835/900 Body
DEVICE UNDER TEST:	Intermec 700 CXL	RELATIVE PERMITTIVITY:	58.12
RELATIVE HUMIDITY:	33.1%	CONDUCTIVITY:	0.991
PHANTOM S/NO:	HeadBox02.csv	LIQUID TEMPERATURE:	25°C
PHANTOM ROTATION:	0°	MAX SAR Y-AXIS LOCATION:	4.80 mm
DUT POSITION:	Holster 1 (Normal) Front	MAX SAR Z-AXIS LOCATION:	-99.95 mm
ANTENNA CONFIGURATION:	External	MAX E FIELD:	24.69 V/m
TEST FREQUENCY:	836.4MHz	SAR 1g:	0.544 W/kg
AIR FACTORS:	500 / 410 / 385	SAR 10g:	0.384 W/kg
CONVERSION FACTORS:	0.3 / 0.3 / 0.3	SAR START:	0.245 W/kg
TYPE OF MODULATION:	GPRS	SAR END:	0.237 W/kg
MODN. DUTY CYCLE:	25%	SAR DRIFT DURING SCAN:	-0.15 dB
DIODE COMPRESSION FACTORS (V*200):	16.1 / 16.1 / 14.7	PROBE BATTERY LAST CHANGED:	22/11/04
INPUT POWER LEVEL:	33dBm	EXTRAPOLATION:	poly4

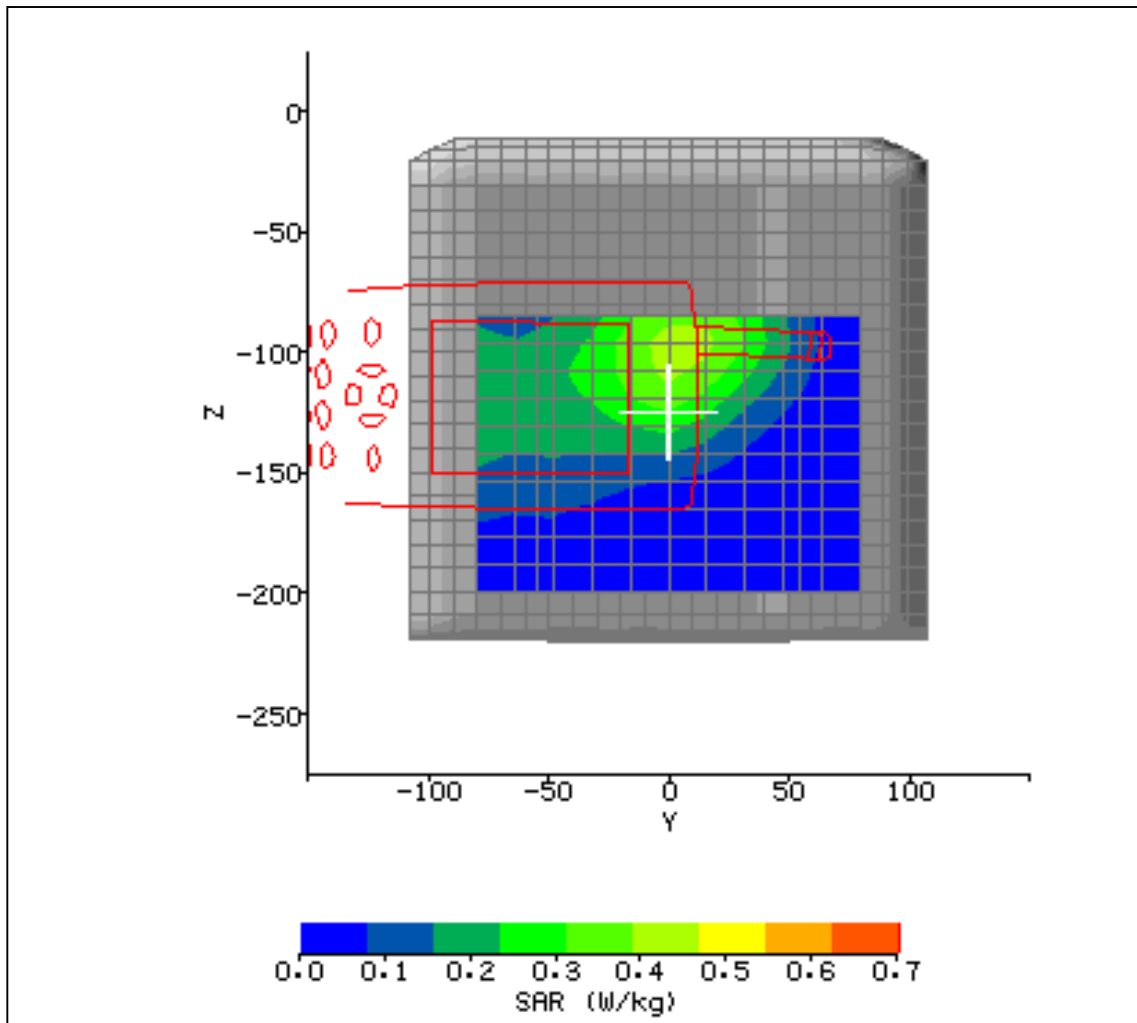

Figure 52



2.8 TEST RESULTS INCLUDING SAR DISTRIBUTIONS (AREA SCANS – 2D)

SYSTEM / SOFTWARE:	SARA2 / 2.3 VPM	INPUT POWER DRIFT:	0.0dBm
DATE / TIME:	24/11/2004 09:48:10	DUT BATTERY MODEL/NO:	318-103-002
FILENAME:	613256_02_024.txt	PROBE SERIAL NUMBER:	084
AMBIENT TEMPERATURE:	25.3°C	LIQUID SIMULANT:	835/900 Body
DEVICE UNDER TEST:	Intermec 700 CXL	RELATIVE PERMITTIVITY:	58.12
RELATIVE HUMIDITY:	34%	CONDUCTIVITY:	0.991
PHANTOM S/NO:	HeadBox02.csv	LIQUID TEMPERATURE:	24.9°C
PHANTOM ROTATION:	0°	MAX SAR Y-AXIS LOCATION:	3.20 mm
DUT POSITION:	Holster 1 (Normal) Front	MAX SAR Z-AXIS LOCATION:	-101.10 mm
ANTENNA CONFIGURATION:	External	MAX E FIELD:	23.22 V/m
TEST FREQUENCY:	824.2MHz	SAR 1g:	0.482 W/kg
AIR FACTORS:	500 / 410 / 385	SAR 10g:	0.343 W/kg
CONVERSION FACTORS:	0.3 / 0.3 / 0.3	SAR START:	0.226 W/kg
TYPE OF MODULATION:	GPRS	SAR END:	0.220 W/kg
MODN. DUTY CYCLE:	25%	SAR DRIFT DURING SCAN:	-0.10 dB
DIODE COMPRESSION FACTORS (V*200):	16.1 / 16.1 / 14.7	PROBE BATTERY LAST CHANGED:	22/11/04
INPUT POWER LEVEL:	33dBm	EXTRAPOLATION:	poly4

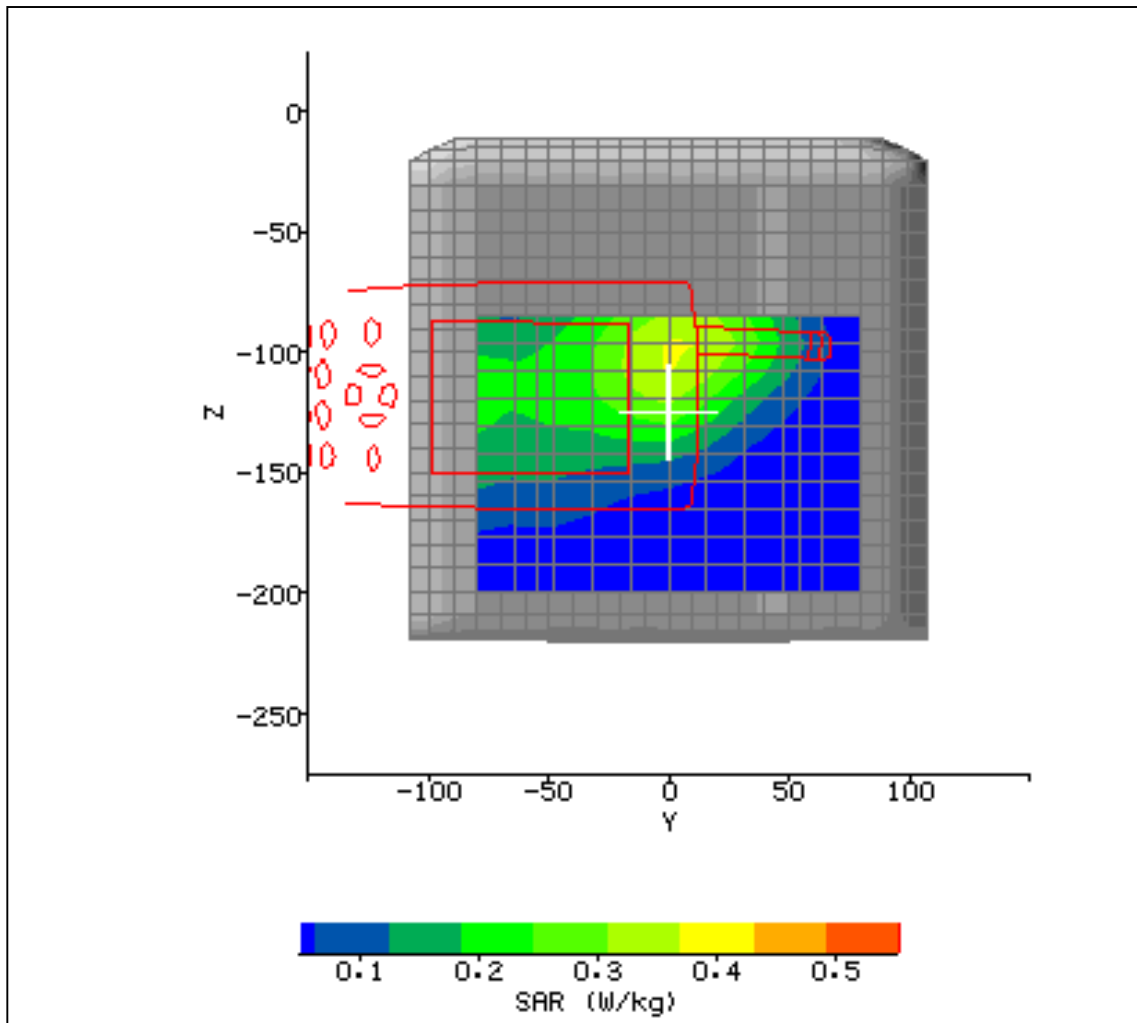

Figure 53



2.8 TEST RESULTS INCLUDING SAR DISTRIBUTIONS (AREA SCANS – 2D)

SYSTEM / SOFTWARE:	SARA2 / 2.3 VPM	INPUT POWER DRIFT:	0.0dBm
DATE / TIME:	24/11/2004 10:45:19	DUT BATTERY MODEL/NO:	318-103-002
FILENAME:	613256_02_025.txt	PROBE SERIAL NUMBER:	084
AMBIENT TEMPERATURE:	24.6°C	LIQUID SIMULANT:	835/900 Body
DEVICE UNDER TEST:	Intermec 700 CXL	RELATIVE PERMITTIVITY:	58.12
RELATIVE HUMIDITY:	36.5%	CONDUCTIVITY:	0.991
PHANTOM S/NO:	HeadBox02.csv	LIQUID TEMPERATURE:	24.9°C
PHANTOM ROTATION:	0°	MAX SAR Y-AXIS LOCATION:	3.20 mm
DUT POSITION:	Holster 1 (Normal) Front	MAX SAR Z-AXIS LOCATION:	-99.95 mm
ANTENNA CONFIGURATION:	External	MAX E FIELD:	24.31 V/m
TEST FREQUENCY:	848.8MHz	SAR 1g:	0.526 W/kg
AIR FACTORS:	500 / 410 / 385	SAR 10g:	0.373 W/kg
CONVERSION FACTORS:	0.3 / 0.3 / 0.3	SAR START:	0.248 W/kg
TYPE OF MODULATION:	GPRS	SAR END:	0.240 W/kg
MODN. DUTY CYCLE:	25%	SAR DRIFT DURING SCAN:	-0.15 dB
DIODE COMPRESSION FACTORS (V*200):	16.1 / 16.1 / 14.7	PROBE BATTERY LAST CHANGED:	22/11/04
INPUT POWER LEVEL:	33dBm	EXTRAPOLATION:	poly4

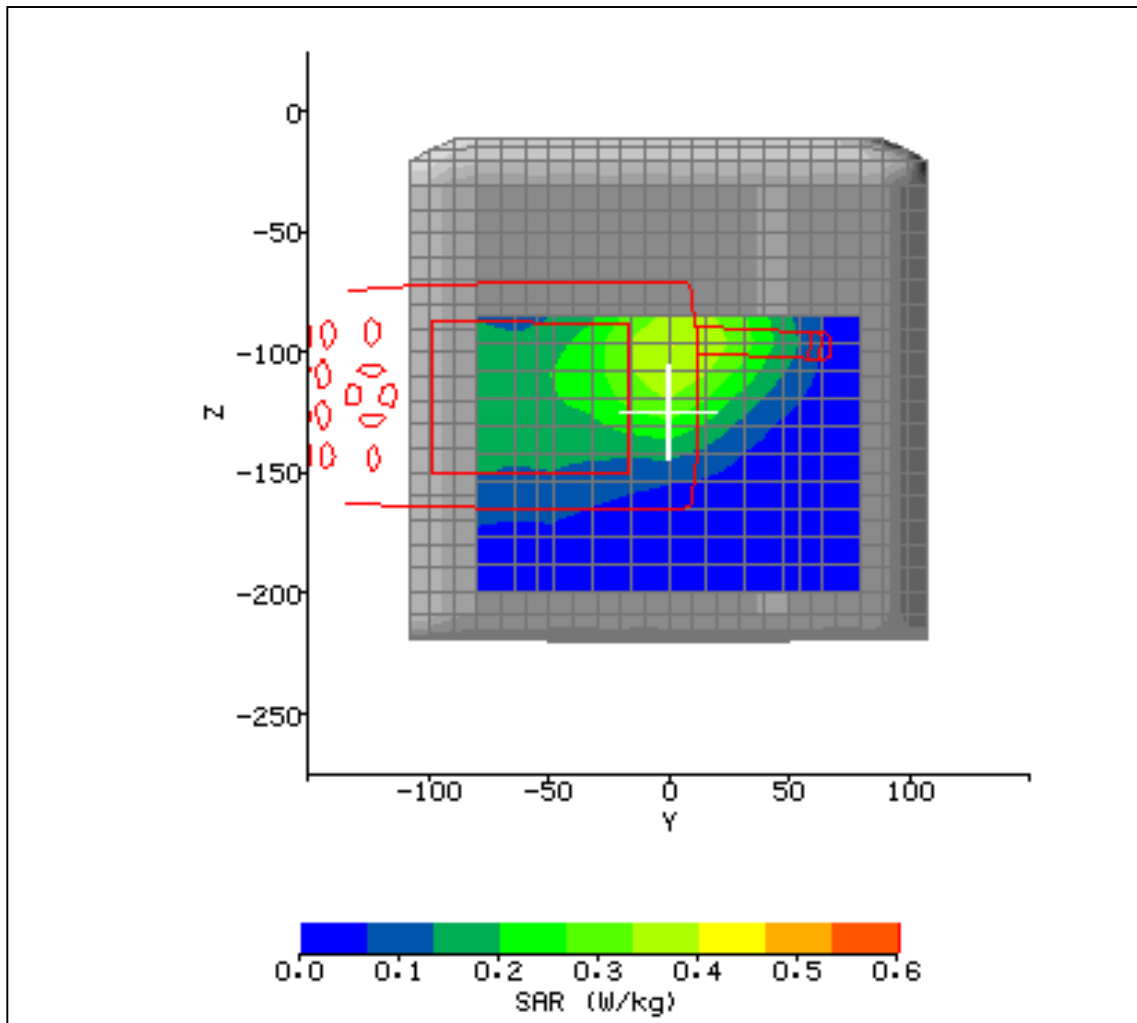

Figure 54



2.8 TEST RESULTS INCLUDING SAR DISTRIBUTIONS (AREA SCANS – 2D)

SYSTEM / SOFTWARE:	SARA2 / 2.3 VPM	INPUT POWER DRIFT:	0.0dBm
DATE / TIME:	24/11/2004 12:52:45	DUT BATTERY MODEL/NO:	318-103-002
FILENAME:	613256_02_027.txt	PROBE SERIAL NUMBER:	084
AMBIENT TEMPERATURE:	24.9°C	LIQUID SIMULANT:	835/900 Body
DEVICE UNDER TEST:	Intermec 700 CXL	RELATIVE PERMITTIVITY:	58.12
RELATIVE HUMIDITY:	36.2%	CONDUCTIVITY:	0.991
PHANTOM S/NO:	HeadBox02.csv	LIQUID TEMPERATURE:	24.2°C
PHANTOM ROTATION:	0°	MAX SAR Y-AXIS LOCATION:	36.80 mm
DUT POSITION:	Holster 2 (Normal) Front	MAX SAR Z-AXIS LOCATION:	-137.90 mm
ANTENNA CONFIGURATION:	External	MAX E FIELD:	24.07 V/m
TEST FREQUENCY:	836.4MHz	SAR 1g:	0.508 W/kg
AIR FACTORS:	500 / 410 / 385	SAR 10g:	0.362 W/kg
CONVERSION FACTORS:	0.3 / 0.3 / 0.3	SAR START:	0.262 W/kg
TYPE OF MODULATION:	GPRS	SAR END:	0.260 W/kg
MODN. DUTY CYCLE:	25%	SAR DRIFT DURING SCAN:	-0.04 dB
DIODE COMPRESSION FACTORS (V*200):	16.1 / 16.1 / 14.7	PROBE BATTERY LAST CHANGED:	22/11/04
INPUT POWER LEVEL:	33dBm	EXTRAPOLATION:	poly4

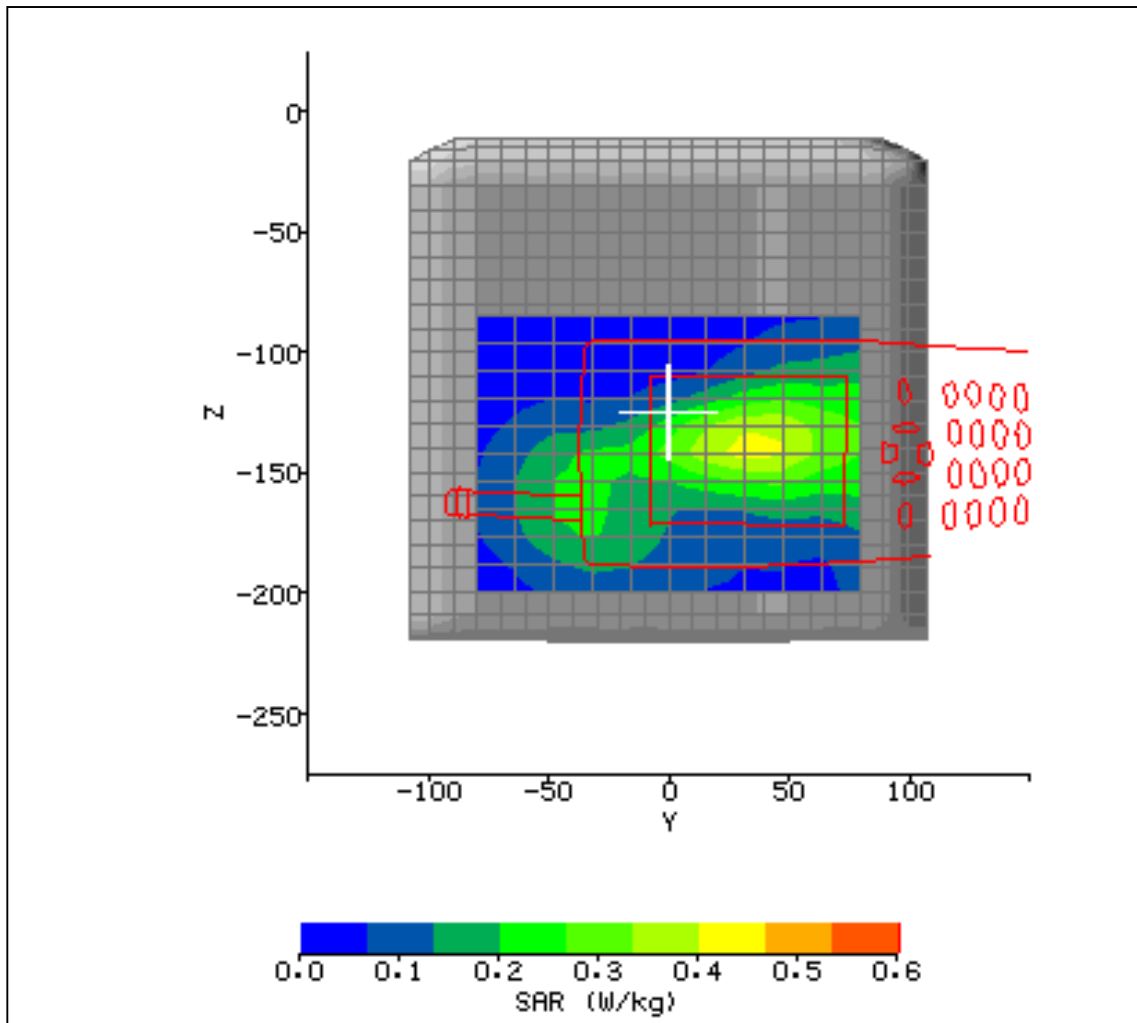

Figure 55



2.8 TEST RESULTS INCLUDING SAR DISTRIBUTIONS (AREA SCANS – 2D)

SYSTEM / SOFTWARE:	SARA2 / 2.3 VPM	INPUT POWER DRIFT:	0.0dBm
DATE / TIME:	24/11/2004 13:38:04	DUT BATTERY MODEL/NO:	318-103-002
FILENAME:	613256_02_028.txt	PROBE SERIAL NUMBER:	084
AMBIENT TEMPERATURE:	23.6°C	LIQUID SIMULANT:	835/900 Body
DEVICE UNDER TEST:	Intermec 700 CXL	RELATIVE PERMITTIVITY:	58.12
RELATIVE HUMIDITY:	39.6%	CONDUCTIVITY:	0.991
PHANTOM S/NO:	HeadBox02.csv	LIQUID TEMPERATURE:	24°C
PHANTOM ROTATION:	0°	MAX SAR Y-AXIS LOCATION:	40.00 mm
DUT POSITION:	Holster 2 (Inverted) scan1	MAX SAR Z-AXIS LOCATION:	-154.00 mm
ANTENNA CONFIGURATION:	External	MAX E FIELD:	18.13 V/m
TEST FREQUENCY:	836.4MHz	SAR 1g:	0.291 W/kg
AIR FACTORS:	500 / 410 / 385	SAR 10g:	0.208 W/kg
CONVERSION FACTORS:	0.3 / 0.3 / 0.3	SAR START:	0.140 W/kg
TYPE OF MODULATION:	GPRS	SAR END:	0.138 W/kg
MODN. DUTY CYCLE:	25%	SAR DRIFT DURING SCAN:	-0.05 dB
DIODE COMPRESSION FACTORS (V*200):	16.1 / 16.1 / 14.7	PROBE BATTERY LAST CHANGED:	22/11/04
INPUT POWER LEVEL:	33dBm	EXTRAPOLATION:	poly4

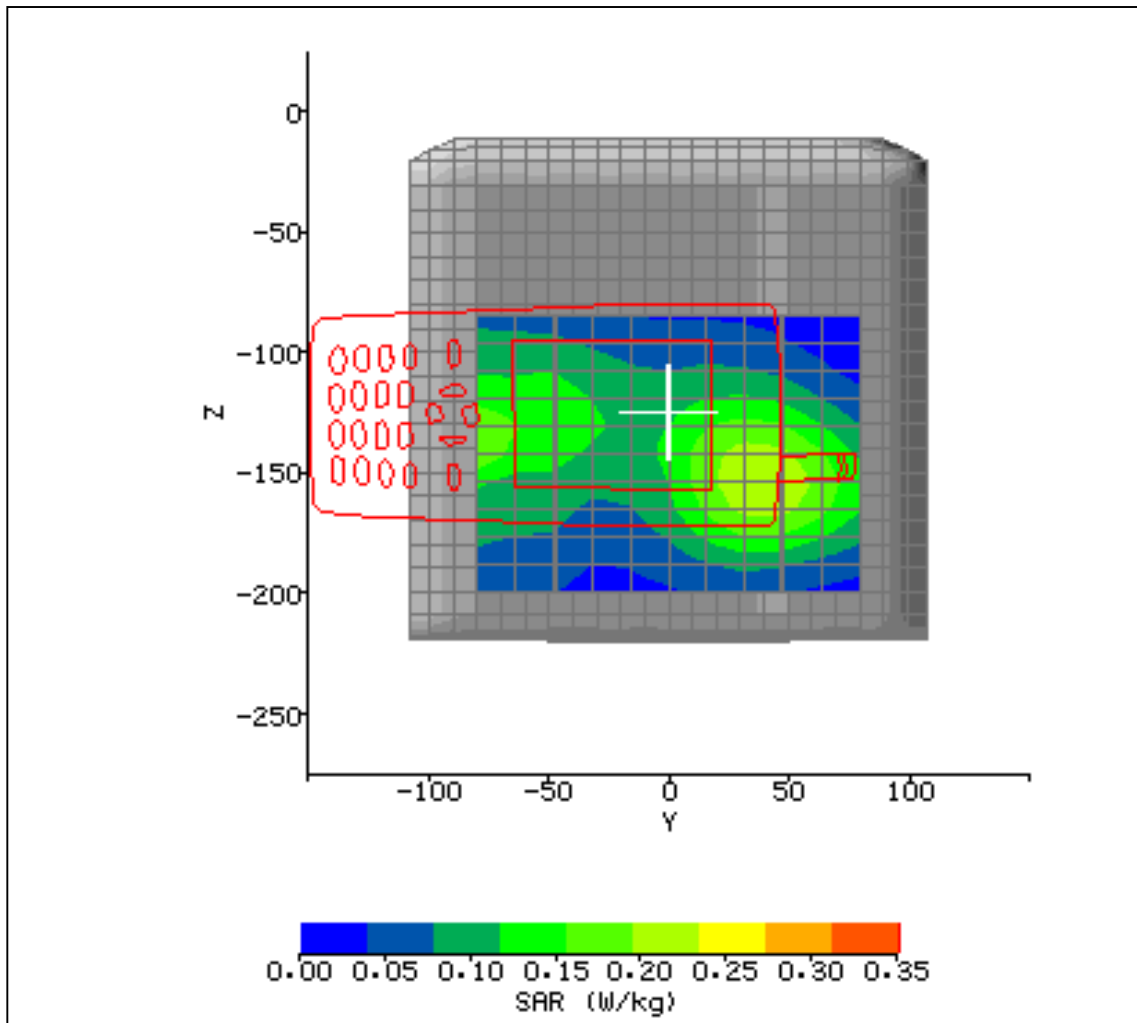

Figure 56



2.8 TEST RESULTS INCLUDING SAR DISTRIBUTIONS (AREA SCANS – 2D)

SYSTEM / SOFTWARE:	SARA2 / 2.3 VPM	INPUT POWER DRIFT:	0.0dBm
DATE / TIME:	24/11/2004 14:18:48	DUT BATTERY MODEL/NO:	318-103-002
FILENAME:	613256_02_028b.txt	PROBE SERIAL NUMBER:	084
AMBIENT TEMPERATURE:	23.8°C	LIQUID SIMULANT:	835/900 Body
DEVICE UNDER TEST:	Intermec 700 CXL	RELATIVE PERMITTIVITY:	58.12
RELATIVE HUMIDITY:	40.2%	CONDUCTIVITY:	0.991
PHANTOM S/NO:	HeadBox02.csv	LIQUID TEMPERATURE:	24.1°C
PHANTOM ROTATION:	0°	MAX SAR Y-AXIS LOCATION:	-36.80 mm
DUT POSITION:	Holster 2 (Inverted) scan2	MAX SAR Z-AXIS LOCATION:	-135.60 mm
ANTENNA CONFIGURATION:	External	MAX E FIELD:	18.75 V/m
TEST FREQUENCY:	836.4MHz	SAR 1g:	0.312 W/kg
AIR FACTORS:	500 / 410 / 385	SAR 10g:	0.223 W/kg
CONVERSION FACTORS:	0.3 / 0.3 / 0.3	SAR START:	0.162 W/kg
TYPE OF MODULATION:	GPRS	SAR END:	0.162 W/kg
MODN. DUTY CYCLE:	25%	SAR DRIFT DURING SCAN:	0.01 dB
DIODE COMPRESSION FACTORS (V*200):	16.1 / 16.1 / 14.7	PROBE BATTERY LAST CHANGED:	22/11/04
INPUT POWER LEVEL:	33dBm	EXTRAPOLATION:	poly4

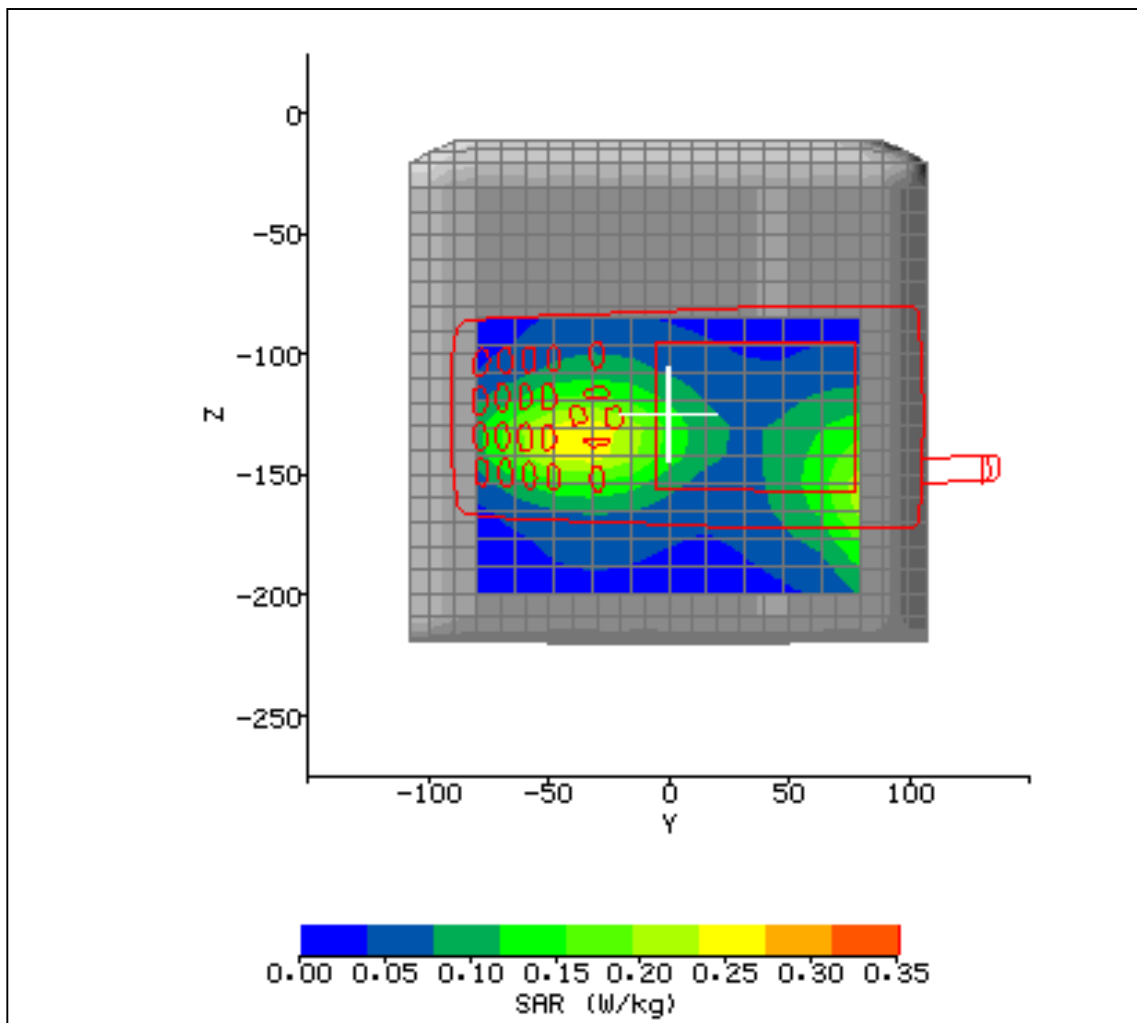

Figure 57



2.8 TEST RESULTS INCLUDING SAR DISTRIBUTIONS (AREA SCANS – 2D)

SYSTEM / SOFTWARE:	SARA2 / 2.3 VPM	INPUT POWER DRIFT:	0.0dBm
DATE / TIME:	24/11/2004 15:23:48	DUT BATTERY MODEL/NO:	318-103-002
FILENAME:	613256_02_029.txt	PROBE SERIAL NUMBER:	084
AMBIENT TEMPERATURE:	24.4°C	LIQUID SIMULANT:	835/900 Body
DEVICE UNDER TEST:	Intermec 700 CXL	RELATIVE PERMITTIVITY:	58.12
RELATIVE HUMIDITY:	34%	CONDUCTIVITY:	0.991
PHANTOM S/NO:	HeadBox02.csv	LIQUID TEMPERATURE:	24.1°C
PHANTOM ROTATION:	0°	MAX SAR Y-AXIS LOCATION:	-43.20 mm
DUT POSITION:	Holster 2 (Inverted) Front	MAX SAR Z-AXIS LOCATION:	-137.90 mm
ANTENNA CONFIGURATION:	External	MAX E FIELD:	24.86 V/m
TEST FREQUENCY:	836.4MHz	SAR 1g:	0.540 W/kg
AIR FACTORS:	500 / 410 / 385	SAR 10g:	0.375 W/kg
CONVERSION FACTORS:	0.3 / 0.3 / 0.3	SAR START:	0.263 W/kg
TYPE OF MODULATION:	GPRS	SAR END:	0.265 W/kg
MODN. DUTY CYCLE:	25%	SAR DRIFT DURING SCAN:	0.04 dB
DIODE COMPRESSION FACTORS (V*200):	16.1 / 16.1 / 14.7	PROBE BATTERY LAST CHANGED:	22/11/04
INPUT POWER LEVEL:	33dBm	EXTRAPOLATION:	poly4

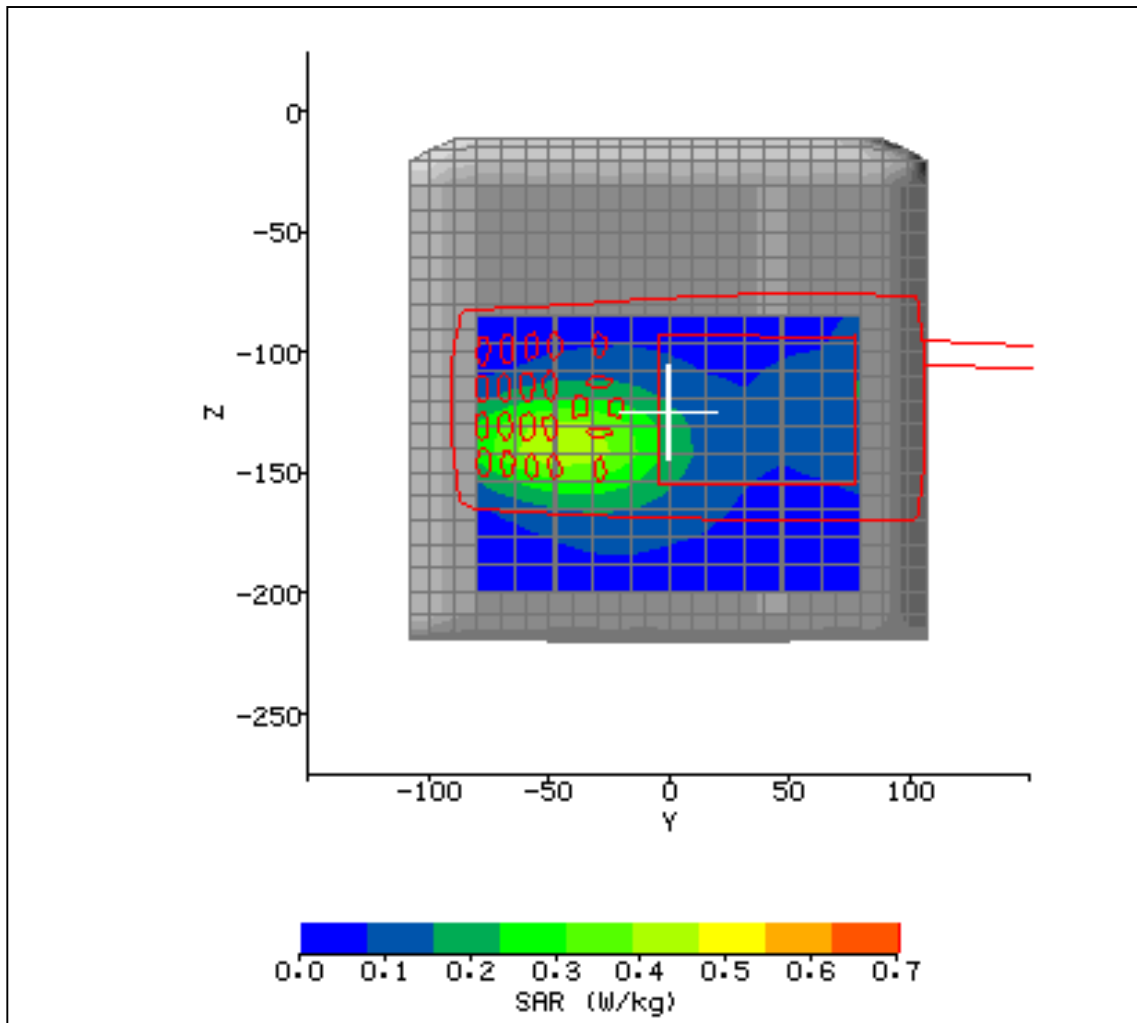

Figure 58



2.8 TEST RESULTS INCLUDING SAR DISTRIBUTIONS (AREA SCANS – 2D)

SYSTEM / SOFTWARE:	SARA2 / 2.3 VPM	INPUT POWER DRIFT:	0.0dBm
DATE / TIME:	24/11/2004 16:29:30	DUT BATTERY MODEL/NO:	318-103-002
FILENAME:	613256_02_030.txt	PROBE SERIAL NUMBER:	084
AMBIENT TEMPERATURE:	23.3°C	LIQUID SIMULANT:	835/900 Body
DEVICE UNDER TEST:	Intermec 700 CXL	RELATIVE PERMITTIVITY:	58.12
RELATIVE HUMIDITY:	42.4%	CONDUCTIVITY:	0.991
PHANTOM S/NO:	HeadBox02.csv	LIQUID TEMPERATURE:	23.5°C
PHANTOM ROTATION:	0°	MAX SAR Y-AXIS LOCATION:	-40.00 mm
DUT POSITION:	Holster 2 (edge) normal	MAX SAR Z-AXIS LOCATION:	-134.45 mm
ANTENNA CONFIGURATION:	External	MAX E FIELD:	21.77 V/m
TEST FREQUENCY:	836.4MHz	SAR 1g:	0.414 W/kg
AIR FACTORS:	500 / 410 / 385	SAR 10g:	0.284 W/kg
CONVERSION FACTORS:	0.3 / 0.3 / 0.3	SAR START:	0.208 W/kg
TYPE OF MODULATION:	GPRS	SAR END:	0.202 W/kg
MODN. DUTY CYCLE:	25%	SAR DRIFT DURING SCAN:	-0.11 dB
DIODE COMPRESSION FACTORS (V*200):	16.1 / 16.1 / 14.7	PROBE BATTERY LAST CHANGED:	22/11/04
INPUT POWER LEVEL:	33dBm	EXTRAPOLATION:	poly4

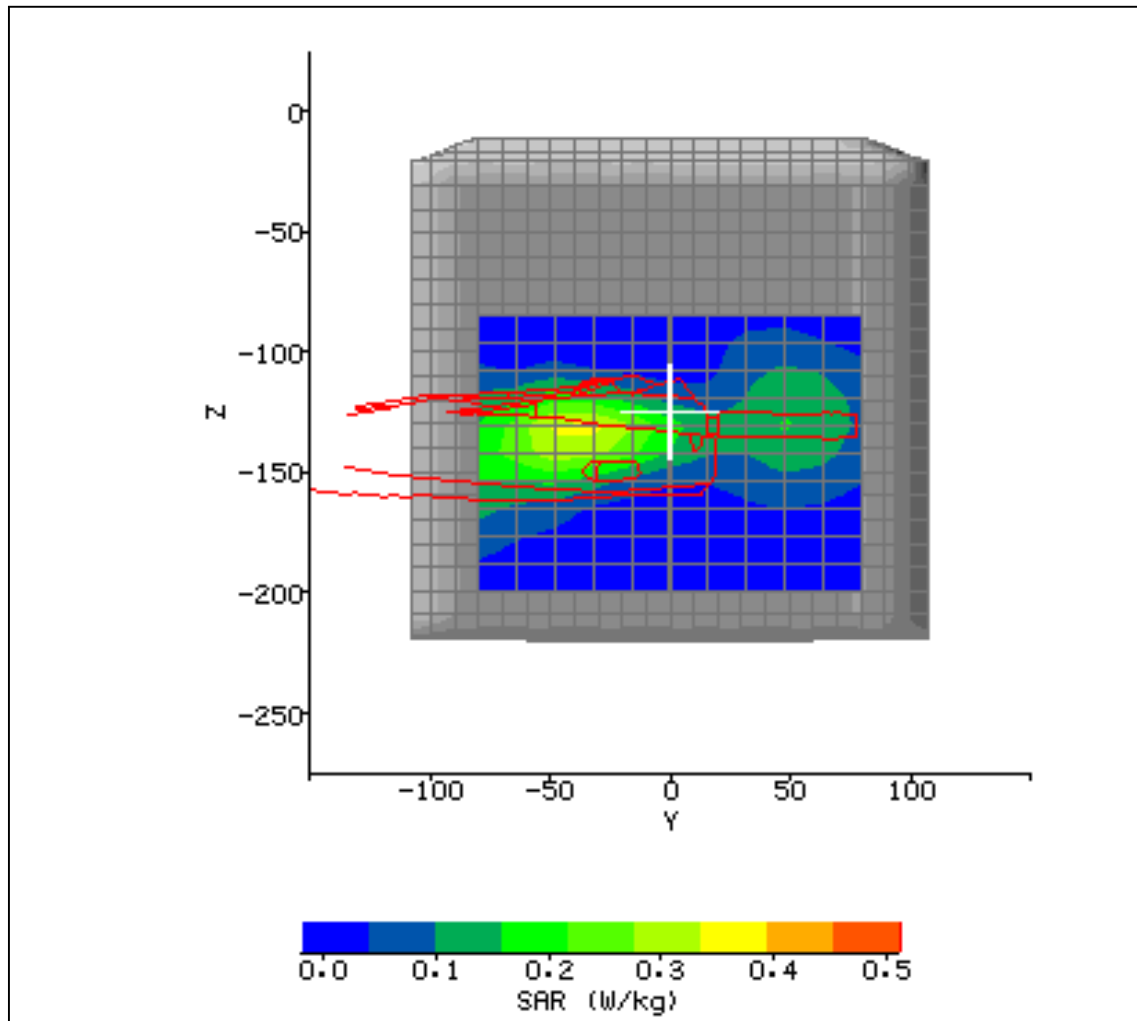

Figure 59



SYSTEM / SOFTWARE:	SARA2 / 2.3 VPM	INPUT POWER DRIFT:	0.0dBm
DATE / TIME:	24/11/2004 17:20:07	DUT BATTERY MODEL/NO:	318-103-002
FILENAME:	613256_02_031.txt	PROBE SERIAL NUMBER:	084
AMBIENT TEMPERATURE:	23.3°C	LIQUID SIMULANT:	835/900 Body
DEVICE UNDER TEST:	Intermec 700 CXL	RELATIVE PERMITTIVITY:	58.12
RELATIVE HUMIDITY:	40.1%	CONDUCTIVITY:	0.991
PHANTOM S/NO:	HeadBox02.csv	LIQUID TEMPERATURE:	23.5°C
PHANTOM ROTATION:	0°	MAX SAR Y-AXIS LOCATION:	-48.00 mm
DUT POSITION:	Holster 2 (edge) inverted	MAX SAR Z-AXIS LOCATION:	-142.50 mm
ANTENNA CONFIGURATION:	External	MAX E FIELD:	21.34 V/m
TEST FREQUENCY:	836.4MHz	SAR 1g:	0.407 W/kg
AIR FACTORS:	500 / 410 / 385	SAR 10g:	0.292 W/kg
CONVERSION FACTORS:	0.3 / 0.3 / 0.3	SAR START:	0.199 W/kg
TYPE OF MODULATION:	GPRS	SAR END:	0.196 W/kg
MODN. DUTY CYCLE:	25%	SAR DRIFT DURING SCAN:	-0.08 dB
DIODE COMPRESSION FACTORS (V*200):	16.1 / 16.1 / 14.7	PROBE BATTERY LAST CHANGED:	22/11/04
INPUT POWER LEVEL:	33dBm	EXTRAPOLATION:	poly4

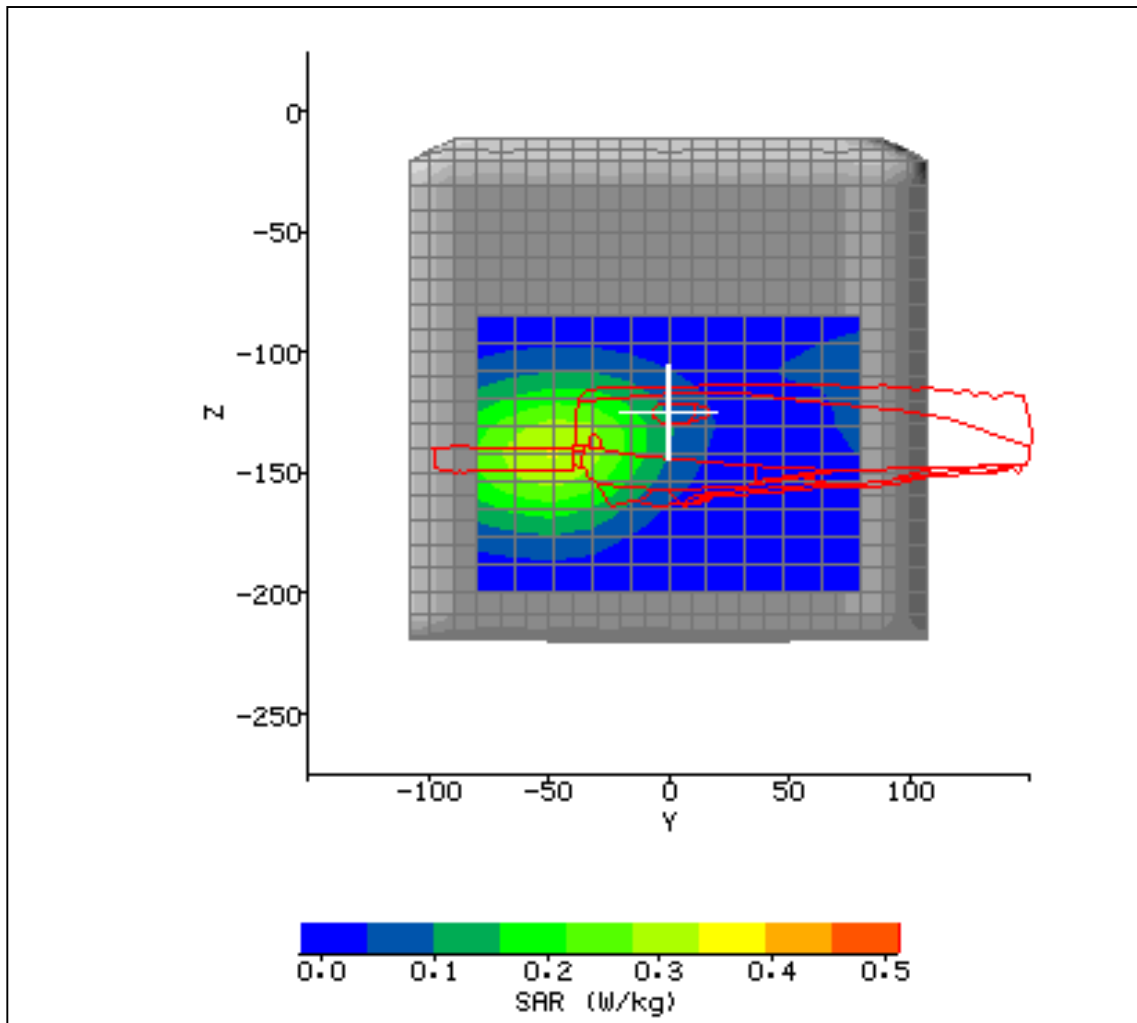

Figure 60



2.8 TEST RESULTS INCLUDING SAR DISTRIBUTIONS (AREA SCANS – 2D)

SYSTEM / SOFTWARE:	SARA2 / 2.3 VPM	INPUT POWER DRIFT:	0.0dBm
DATE / TIME:	24/11/2004 11:52:19	DUT BATTERY MODEL/NO:	318-103-002
FILENAME:	613256_02_026.txt	PROBE SERIAL NUMBER:	084
AMBIENT TEMPERATURE:	23.8°C	LIQUID SIMULANT:	835/900 Body
DEVICE UNDER TEST:	Intermec 700 CXL	RELATIVE PERMITTIVITY:	58.12
RELATIVE HUMIDITY:	39.2%	CONDUCTIVITY:	0.991
PHANTOM S/NO:	HeadBox02.csv	LIQUID TEMPERATURE:	24.3°C
PHANTOM ROTATION:	0°	MAX SAR Y-AXIS LOCATION:	27.20 mm
DUT POSITION:	Belt clip rear facing	MAX SAR Z-AXIS LOCATION:	-137.90 mm
ANTENNA CONFIGURATION:	External	MAX E FIELD:	14.40 V/m
TEST FREQUENCY:	836.4MHz	SAR 1g:	0.180 W/kg
AIR FACTORS:	500 / 410 / 385	SAR 10g:	0.128 W/kg
CONVERSION FACTORS:	0.279 / 0.279 / 0.279	SAR START:	0.085 W/kg
TYPE OF MODULATION:	GPRS	SAR END:	0.081 W/kg
MODN. DUTY CYCLE:	25%	SAR DRIFT DURING SCAN:	-0.19 dB
DIODE COMPRESSION FACTORS (V*200):	10.9 / 13 / 11.4	PROBE BATTERY LAST CHANGED:	22/11/04
INPUT POWER LEVEL:	33dBm	EXTRAPOLATION:	poly4

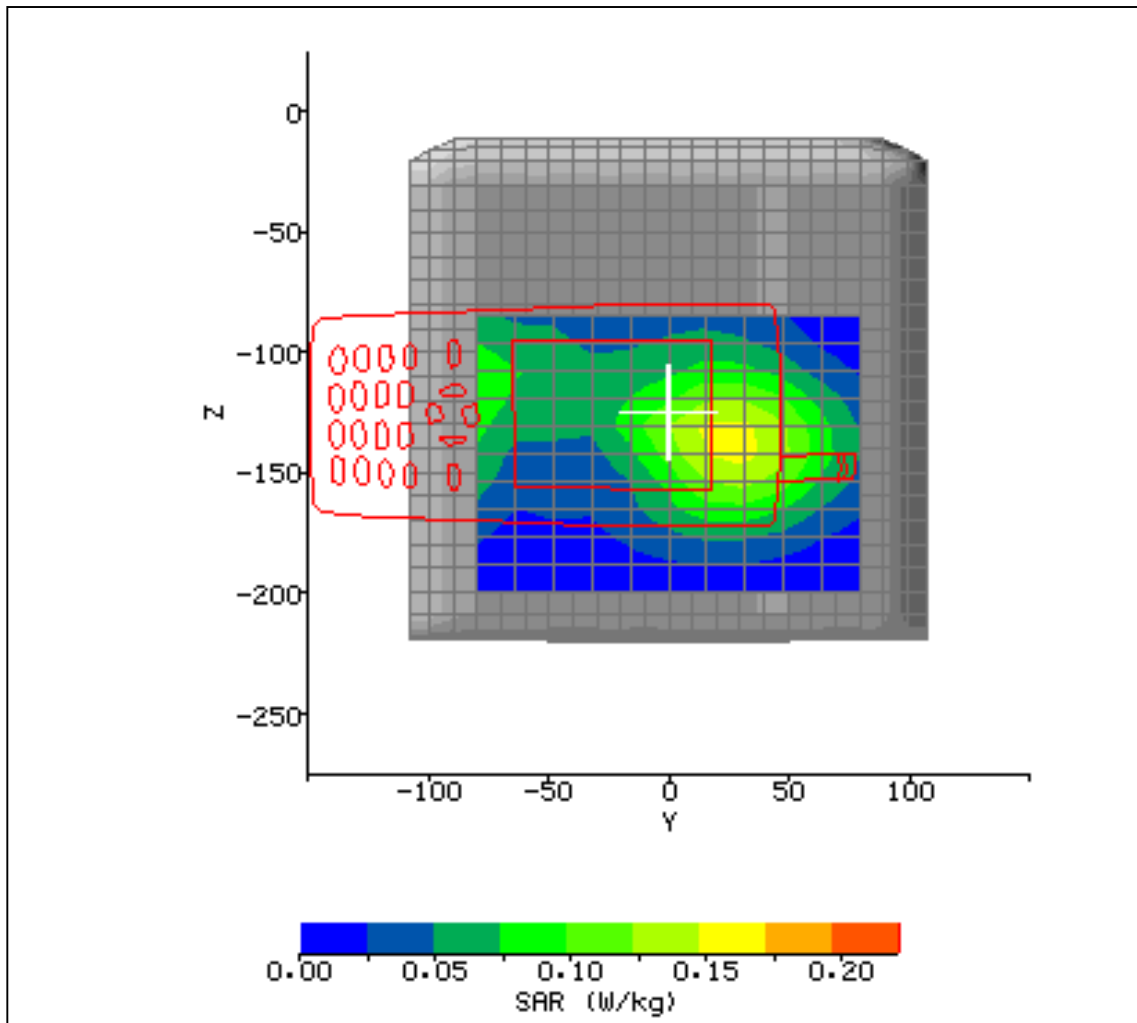

Figure 61



2.8 TEST RESULTS INCLUDING SAR DISTRIBUTIONS (AREA SCANS – 2D)

SYSTEM / SOFTWARE:	SARA2 / 2.3 VPM	INPUT POWER DRIFT:	0.0dBm
DATE / TIME:	22/11/2004 16:31:51	DUT BATTERY MODEL/NO:	318-103-002
FILENAME:	613256_02_017.txt	PROBE SERIAL NUMBER:	084
AMBIENT TEMPERATURE:	24.9°C	LIQUID SIMULANT:	1900 Body
DEVICE UNDER TEST:	Intermec 700 CXL	RELATIVE PERMITTIVITY:	51.44
RELATIVE HUMIDITY:	34.6%	CONDUCTIVITY:	1.566
PHANTOM S/NO:	HeadBox01.csv	LIQUID TEMPERATURE:	24°C
PHANTOM ROTATION:	0°	MAX SAR Y-AXIS LOCATION:	-4.80 mm
DUT POSITION:	Belt Clip Rear Facing	MAX SAR Z-AXIS LOCATION:	-142.50 mm
ANTENNA CONFIGURATION:	External	MAX E FIELD:	10.22 V/m
TEST FREQUENCY:	1850.2MHz	SAR 1g:	0.142 W/kg
AIR FACTORS:	500 / 410 / 385	SAR 10g:	0.093 W/kg
CONVERSION FACTORS:	0.405 / 0.405 / 0.405	SAR START:	0.052 W/kg
TYPE OF MODULATION:	GPRS	SAR END:	0.051 W/kg
MODN. DUTY CYCLE:	25%	SAR DRIFT DURING SCAN:	-0.06 dB
DIODE COMPRESSION FACTORS (V*200):	16.1 / 16.1 / 14.7	PROBE BATTERY LAST CHANGED:	22/11/04
INPUT POWER LEVEL:	30dBm	EXTRAPOLATION:	poly4

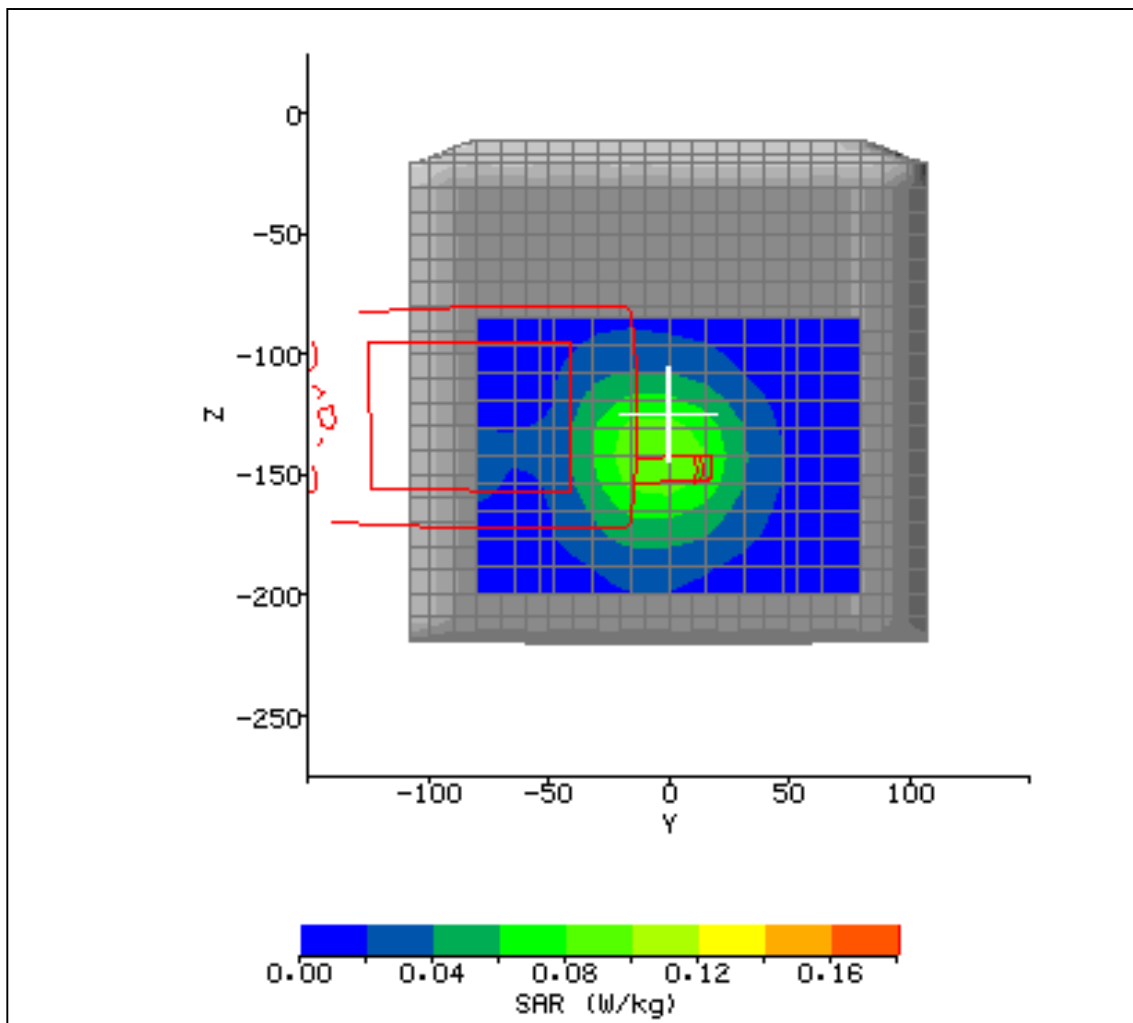

Figure 62

2.9 TEST POSITIONAL PHOTOGRAPHS



Figure 63. Positional photograph of the Intermec 700C Handset in the Left-Hand Cheek position



Figure 64. Positional photograph of the Intermec 700C Handset in the Left-Hand 15 degree position



Figure 65. Positional photograph of the Intermec 700C Handset in the Right-Hand Cheek position



Figure 66. Positional photograph of the Intermec 700C Handset in the Right-Hand 15 degree position

2.9 TEST POSITIONAL PHOTOGRAPHS



Figure 67. Positional photograph of the Intermec 700C
Normal user position, holster 1



Figure 68. Positional photograph of the Intermec 700C
Inverted position, holster 1



Figure 69. Positional photograph of the Intermec 700C
Normal user position, holster 2



Figure 70. Positional photograph of the Intermec 700C
Inverted user position, holster 2



2.9 TEST POSITIONAL PHOTOGRAPHS



Figure 71. Positional photograph of the Intermec 700C Side (normal user) position holster 2

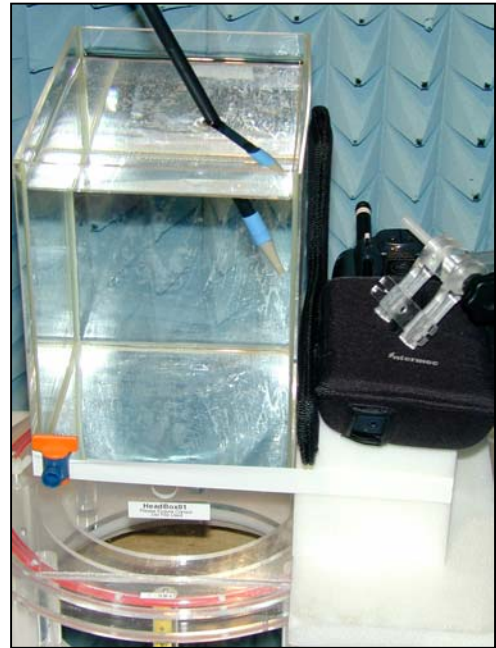

Figure 72. Positional photograph of the Intermec 700C Side (inverted) position holster 2



Figure 73. Positional photograph of the Intermec 700C Rear facing with belt clip



Figure 74. Positional photograph of the Intermec 700C Rear facing with belt clip

2.10 RECORD PHOTOGRAPHS



Figure 75. Front view

2.10 RECORD PHOTOGRAPHS

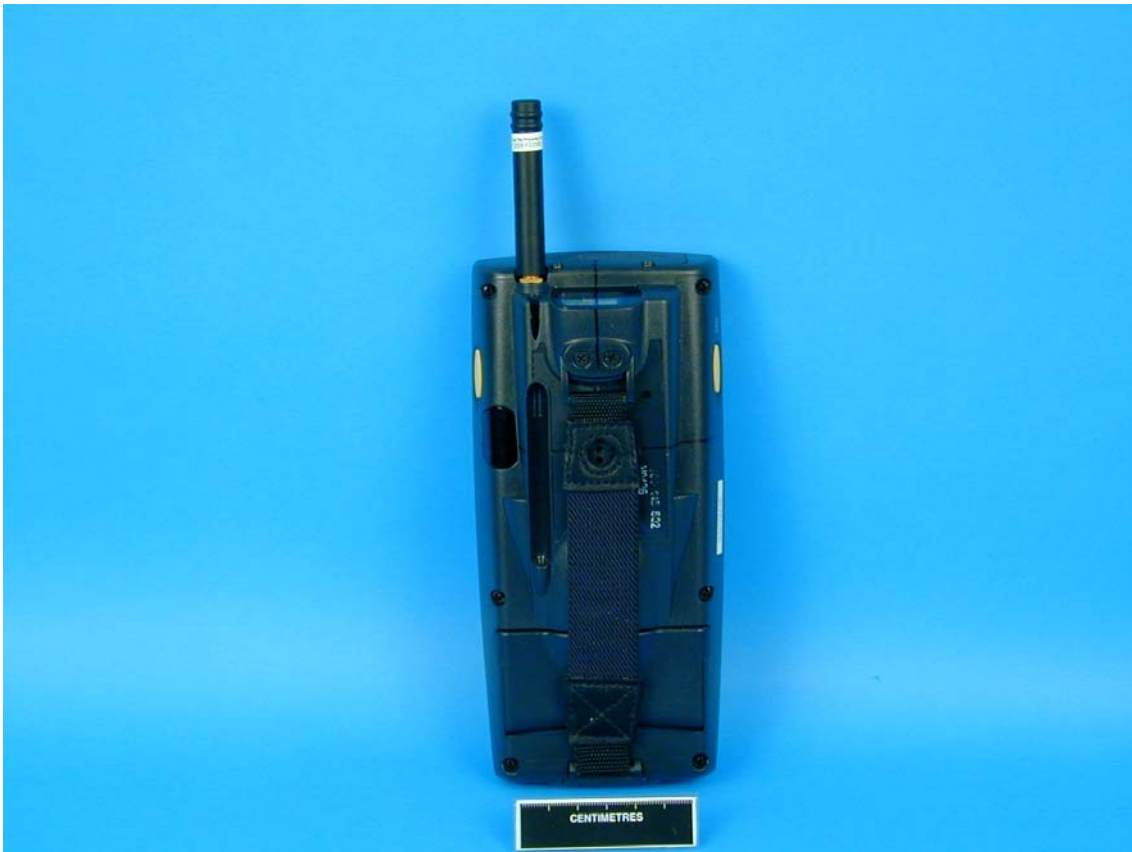

Figure 76. Rear view

2.10 RECORD PHOTOGRAPHS



Figure 77. Rear view with battery removed

2.10 RECORD PHOTOGRAPHS



Figure 78. Holster 1 (for belt) front view

2.10 RECORD PHOTOGRAPHS



Figure 79. Holster 2 (waist / leg) and leg front View

2.10 RECORD PHOTOGRAPHS



Figure 80. Holster 2 (waist / leg side view)

2.10 RECORD PHOTOGRAPHS



Figure 81. Side view showing belt clip

FCC ID: EHASMC46
IC: 1223A-SMC46



2.11 COPYRIGHT STATEMENT

© 2004 TUV Product Service Limited

This report must not be reproduced without the written permission of TUV Product Service Limited.