

TEST REPORT

REPORT NUMBER: I09GW6944-FCC-EMC-3

ON

Type of Equipment: PCI Express Mini Card
Type of Designation: MC8795V
Manufacturer: Flextronics

ACCORDING TO

**FCC CFR Part 2, FREQUENCY ALLOCATIONS AND RADIO
TREATY MATTERS; GENERAL RULES AND REGULATIONS;
e-CFR, April 24, 2009**

PART 22, PUBLIC MOBILE SERVICES e-CFR, April 24, 2009

**PART 24, PERSONAL COMMUNICATIONS SERVICES e-CFR,
April 24, 2009**

China Telecommunication Technology Labs.

Month date, year

Apr,13, 2010

Signature

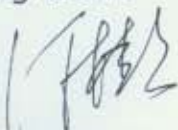

**He Guili
Director**

FCC ID: N7NMC8795

Report Date: 2010-4-13

Test Firm Name: China Telecommunication Technology Labs

Registration Number: 840587

Statement

The measurements shown in this report were made in accordance with the procedures described on test pages. All reported tests were carried out on a sample equipment to demonstrate limited compliance with FCC CFR 47 Parts 2, 22, and 24. The sample tested was found to comply with the requirements defined in the applied rules.

CONTENTS

1 GENERAL INFORMATION	4
1.1 NOTES	4
1.2 TESTERS	5
1.3 TESTING LABORATORY INFORMATION	7
1.4 DETAILS OF APPLICANT OR MANUFACTURER	8
2 TEST ITEM	9
2.1 GENERAL INFORMATION	9
2.2 OUTLINE OF EUT	9
2.3 MODIFICATIONS INCORPORATED IN EUT	9
2.4 EQUIPMENT CONFIGURATION	9
2.5 OTHER INFORMATION	10
3 SUMMARY OF TEST RESULTS	11
4 TEST RESULTS OF MODE	13
4.1 RADIATED SPURIOUS EMISSION	13
4.2 RADIATED RF POWER OUTPUT AND ERP	27
4.3 OCCUPIED BANDWIDTH	30
4.4 FREQUENCY STABILITY OVER TEMPERATURE VARIATION	42
4.5 FREQUENCY STABILITY OVER VOLTAGE VARIATION	46
4.6 CONDUCTED RF POWER OUTPUT	48
4.7 CONDUCTED SPURIOUS EMISSION	52
4.8 BAND EDGE	57
ANNEX A EXTERNAL PHOTOS	65
ANNEX B INTERNAL PHOTOS.....	66
ANNEX C DEVIATIONS FROM PRESCRIBED TEST METHODS.....	69

1 General Information

1.1 Notes

All reported tests were carried out on a sample equipment to demonstrate limited compliance with FCC CFR 47 Parts 2, 22 and 24.

The test results of this test report relate exclusively to the item(s) tested as specified in section 2.

The following deviation from, additions to, or exclusions from the test specifications have been made. See Annex C.

China Telecommunication Technology Labs.(CTTL) authorizes the applicant or manufacturer (see section 1.4) to reproduce this report provided, and the test report may only be reproduced or published in full. Reproduction or publication of extracts from the report requires the prior written approval of CTTL Mr. He Guili.

Any use which a third party makes of this report, or any reliance on or decisions to be made based on it, are the responsibility of such third parties. CTTL accepts no responsibility for damages, if any, suffered by any third party as a result of decisions made or actions based on this report.

FCC Parts 2, 22, 24
Equipment: MC8795V

REPORT NO.: I09GW6944-FCC-EMC-3

1.2 Testers

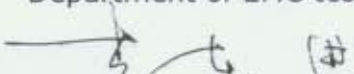
Name: Li Dongjin
Position: Engineer
Department: Department of EMC test
Signature: 

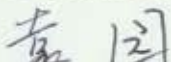
Name: Yuan Yuan
Position: Engineer
Department: Department of EMC test
Signature: 

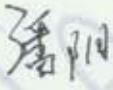
Name: Pan Yang
Position: Engineer
Department: Department of EMC test
Signature: 

Editor of this test report:

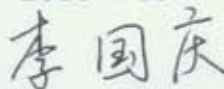
Name: Li Guoqing
Position: Engineer
Department: Department of EMC test
Date: 2010-4-13
Signature: 

Technical responsibility for area of testing:

Name: Zou Dongyi

Position: Manager

Department: Department of EMC test

Date: 2010-4-13

Signature:

EMC Test Report

1.3 Testing Laboratory information

1.3.1 Location

Name: China Telecommunication Technology Labs.
Address: No. 11, Yue Tan Nan Jie, Xi Cheng District
BEIJING
P. R. CHINA, 100045
Tel: +86 10 68094053
Fax: +86 10 68011404
Email: emc@chinattl.com

1.3.2 Details of accreditation status

Accredited by: China National Accreditation Service for Conformity
Assessment (CNAS)
Registration number: CNAS Registration No. CNAS L0570
Standard: ISO/IEC 17025:2005

1.3.3 Test location, where different from section 1.3.1

Name: -----
Street: -----
City: -----
Country: -----
Telephone: -----
Fax: -----
Postcode: -----

1.4 Details of applicant or manufacturer

1.4.1 Applicant

Name: Sierra Wireless, Inc.
Address: 13811, Wireless Way, Richmond, British Columbia
Country: Canada
Telephone: +1 604-232-1440
Fax: +1 604-231-1109
Contact: Ying Wang
Telephone: +86 755 8611 9802
Email: ywang@sierrawireless.com

1.4.2 Manufacturer (if different from applicant in section 1.4.1)

Name: Flextronics
Address: Flextronics Zhuhai Industrial Park (B16), Xin Qing
Science & Technology Industrial Park, Jing An,
Doumen, Zhuhai, GD, China.

1.4.3 Manufactory (if different from applicant in section 1.4.1)

Name: ----
Address: ----

2 Test Item

2.1 General Information

Manufacturer: Flextronics
 Name: PCI Express Mini Card
 Model Number: MC8795V
 Serial Number: 1201477-1.0
 Production Status: Product
 Receipt date of test item: 2009-8-3

2.2 Outline of EUT

EUT is a PCI Express Mini Card supporting GPRS/EGPRS 850/1900 and WCDMA FDD II and V.

2.3 Modifications Incorporated in EUT

The EUT has not been modified from what is described by the brand name and unique type identification stated above.

2.4 Equipment Configuration

Equipment configuration list:

Item	Generic Description	Manufacturer	Type	Serial No.	Remarks
A	PCI Express Mini Card	Flextronics	MC8795V	1201477-1.0	None
B	adapter	--	--	--	None
C	battery	--	--	--	None
D	Earphone	--	--	--	None
E	Antenna	--	3G101	--	None

Cables:

Item	Cable Type	Manufacturer	Length	Shield	Quantity	Remarks
1	DC cable on Adapter	--	--	--	--	None

Note: the EUT has no adaptor, battery, earphone and cable.

2.5 Other Information

- (a) GPRS Modulation is GMSK, emission designator is 252kGXW.
EGPRS modulation is 8PSK, emission designator is 248KG7W.
WCDMA modulation is QPSK, emission designator is 4M21F9W.
- (b) Version of hardware and software
HW Version: Rev1.0
SW Version: K2.0.7.7
- (c) Adaptor information:
The EUT has no adaptor.
- (d) Battery information:
The EUT has no battery.

CITL Test Report

3 Summary of Test Results

A brief summary of the tests carried out is shown as following.

GPRS mode:		
Specification Clause	Name of Test	Result
2.1051, 24.238, 2.1053,22.917	Radiated Spurious Emission	Pass
2.1046,24.232	Radiated RF Power Output	Pass
22.913(a)	Effective Radiated Power (ERP)	Pass
2.1049,22.917(b), 24.238(b)	Occupied Bandwidth	*Note 1
2.1055,22.355, 24.235	Frequency Stability over Temperature Variation	Pass
2.1055,22.355, 24.235	Frequency Stability over Voltage Variation	Pass
2.1046,22.913(a), 24.232(c)	Conducted RF Power Output	Pass
2.1051,22.917,24. 238	Conducted spurious emissions	Pass
Note 1: No applicable performance criteria.		

EGPRS mode:		
2.1051, 24.238, 2.1053,22.917	Radiated Spurious Emission	Pass
2.1046,24.232	Radiated RF Power Output	Pass
22.913(a)	Effective Radiated Power (ERP)	Pass
2.1049,22.917(b), 24.238(b)	Occupied Bandwidth	*Note 2
2.1055,22.355, 24.235	Frequency Stability over Temperature Variation	Pass
2.1055,22.355, 24.235	Frequency Stability over Voltage Variation	Pass
2.1046,22.913(a), 24.232(c)	Conducted RF Power Output	Pass
2.1051,22.917,24. 238	Conducted spurious emissions	Pass
Note 2: No applicable performance criteria.		

WCDMA mode:		
2.1051, 24.238, 2.1053,22.917	Radiated Spurious Emission	Pass
2.1046,24.232	Radiated RF Power Output	Pass
22.913(a)	Effective Radiated Power (ERP)	Pass
2.1049,22.917(b), 24.238(b)	Occupied Bandwidth	*Note 3
2.1055,22.355, 24.235	Frequency Stability over Temperature Variation	Pass
2.1055,22.355, 24.235	Frequency Stability over Voltage Variation	Pass
2.1046,22.913(a), 24.232(c)	Conducted RF Power Output	Pass
2.1051,22.917,24. 238	Conducted spurious emissions	Pass
Note 3: No applicable performance criteria.		

TTL Test Report

4 Test Results of mode

4.1 Radiated Spurious Emission

Specifications:	2.1051, 24.238, 2.1053, 22.917					
Date of Tests	2009-9-8, 2009-9-16					
Test conditions:	Ambient Temperature: 15°C-35°C Relative Humidity: 30%-60% Air pressure: 86-106kPa					
Operation Mode	TX on, channel 190 and 661 for GPRS and EGPRS mode 850 and 1900 band respectively; and channel 4175 and 9400 for WCDMA FDD V and II band respectively.					
Test Results:	Pass					
Test equipment Used:						
Asset Number	Description	Manufacturer	Model Number	Serial Number	Cal Due	State
7805	EMI Test Receiver	R/S	ESI26	100211	2010-01-11	Normal
7330	Ultra Broadband Antenna	SCHWARZBECK	VULB 9160	--	2010-10-26	Normal
7330	Double-Ridged Horn Antenna	R/S	HF906	100037	2010-01-09	Normal
713	Fully-Anechoic Chamber	ETS	11.8m×6.5m×6.3m	--	2010-11-16	Normal
023	Wireless Communications Test Set	Agilent	8960(E5515C)	GB41450323	2010-06-09	Normal
111835	Wireless Communications Test Set	R&S	CMU200	1100000802	--	Normal

Limit Level Construction:

According to Part 24.238 (a), i.e., Out of band emissions. The power of any emission outside of the authorized operating frequency ranges must be attenuated below the transmitting power (P) by a factor of at least $43 + 10 \log(P)$ dB, so the limit level is:
 $P(\text{dBm}) - (43 + 10 \log(P)) \text{ dB} = -13\text{dBm}$

Limits for Radiated spurious emissions(UE)

Frequency range	Limit Level /Resolution Bandwidth
30 MHz to 20000 MHz	-13dBm/1MHz

Test Setup:

The EUT was placed in an anechoic chamber, see figure SP. The Wireless Communications Test Set was used to set the TX channel and power level and modulate the TX signal with different bit patterns. The test was done using an automated test system, where all test equipments were controlled by a

computer.



Figure SP

Test Method:

The measurement was performed accordance with section 2.2.12 of ANSI/TIA-603-B-2002: *Land Mobile FM or PM Communications Equipment Measurement and Performance Standards*.

1 The maximum spurious emissions were searched by turning the azimuth of the turntable, shifting the polarization of the measuring antenna and changing the pose of the EUT.

2 Levels of EUT's transmitter harmonics and suspicious signals were recorded.

3 The recorded levels were corrected in the automated test system with the correction factors given by a substitution calibration made before the measurement. The calibration was made separately for vertical and horizontal polarization and the system uses different correction factors depending on the measuring antenna polarization.

4 The corrected values of radiated spurious emissions indicated as EIRP are reported.

Note:

--

Test Results for GPRS mode:

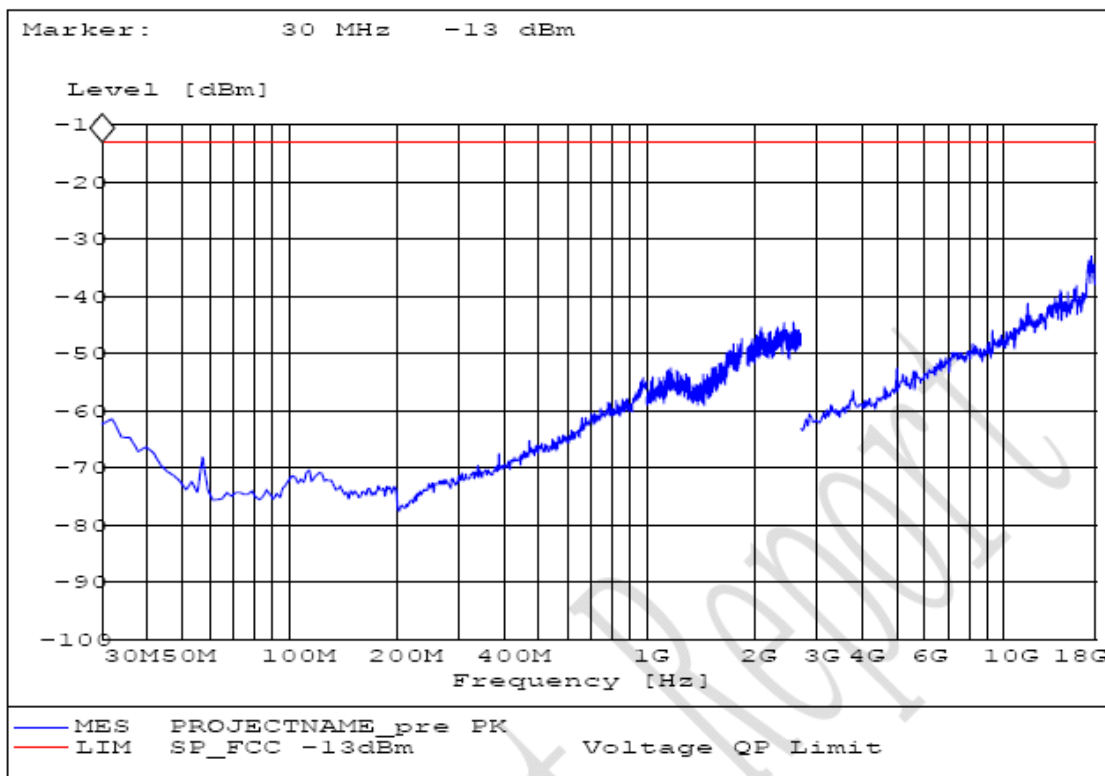

S190VF for GPRS mode

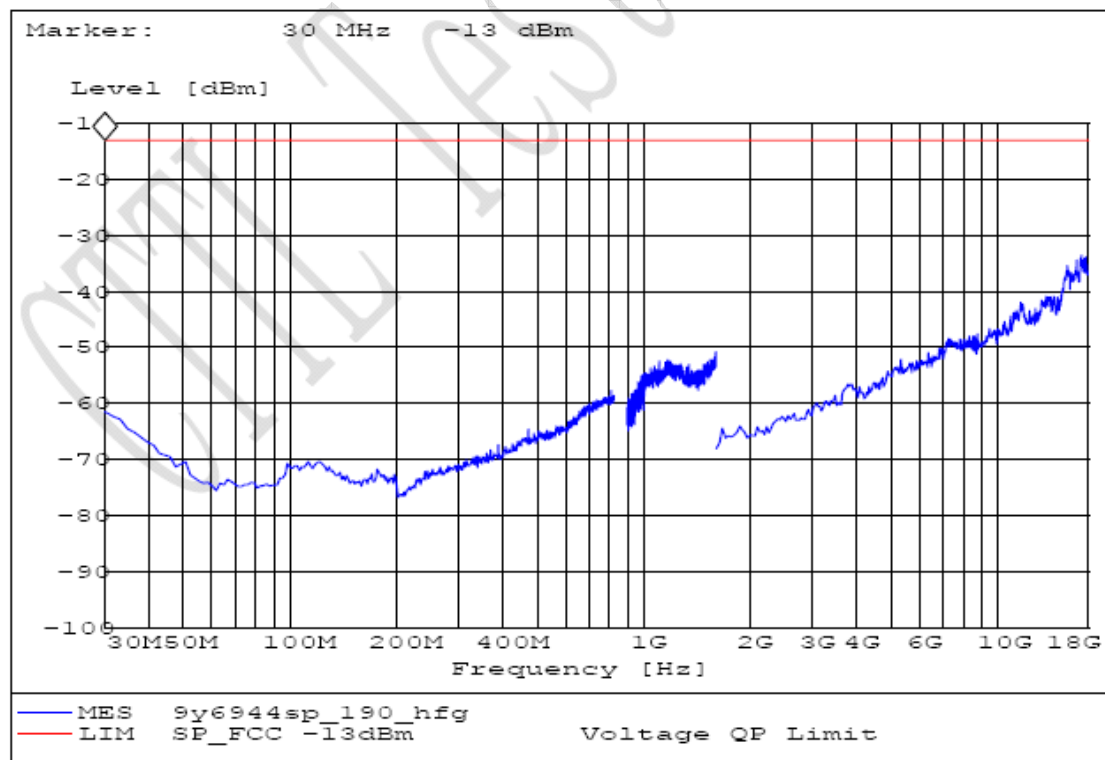

S190HF for GPRS mode

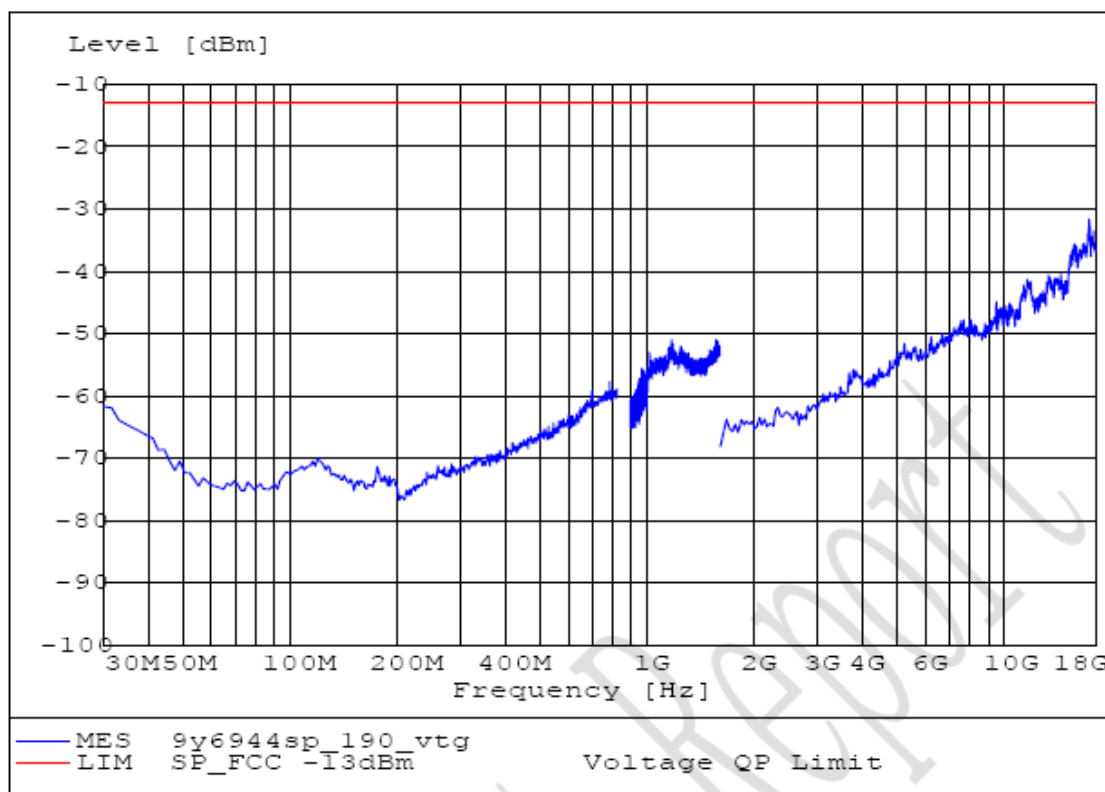

S190VT for GPRS mode

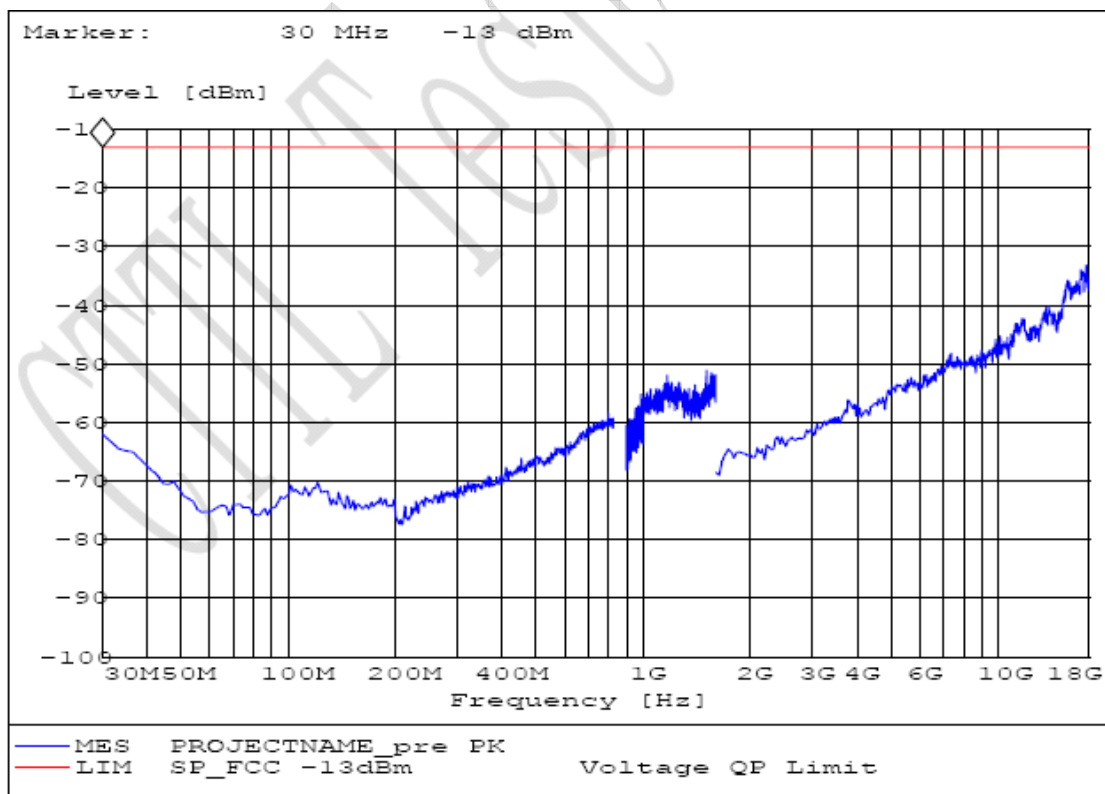

S190HT for GPRS mode

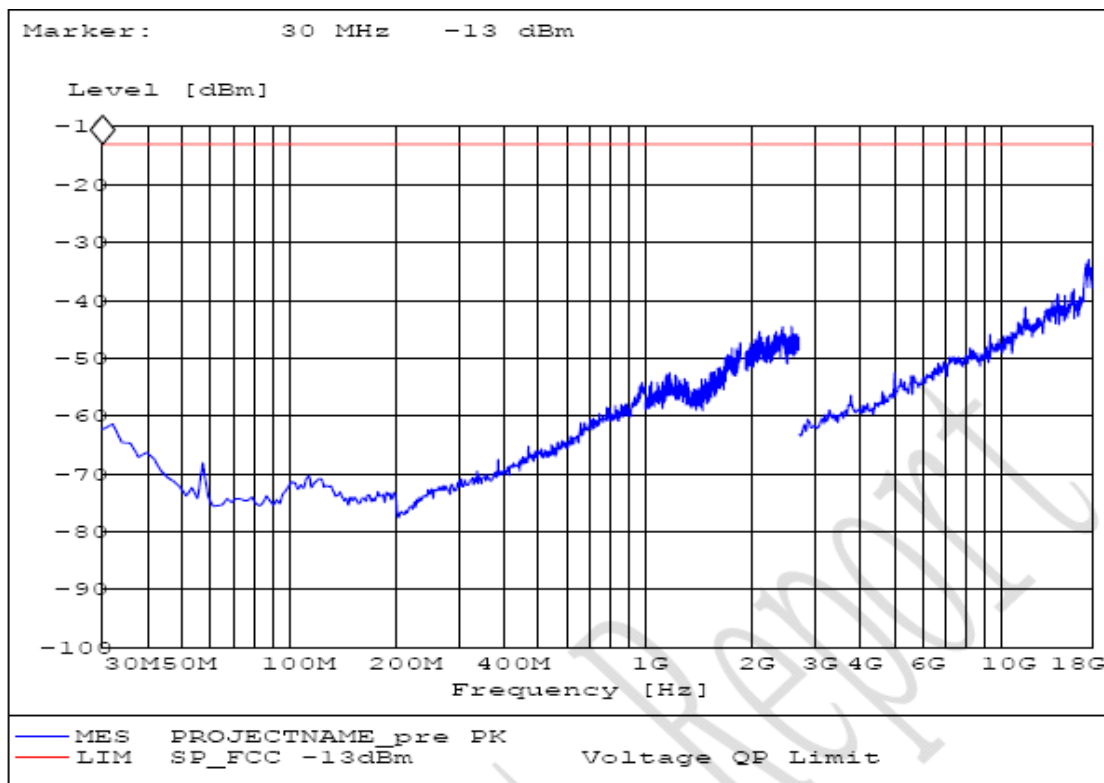

S661VF for GPRS mode

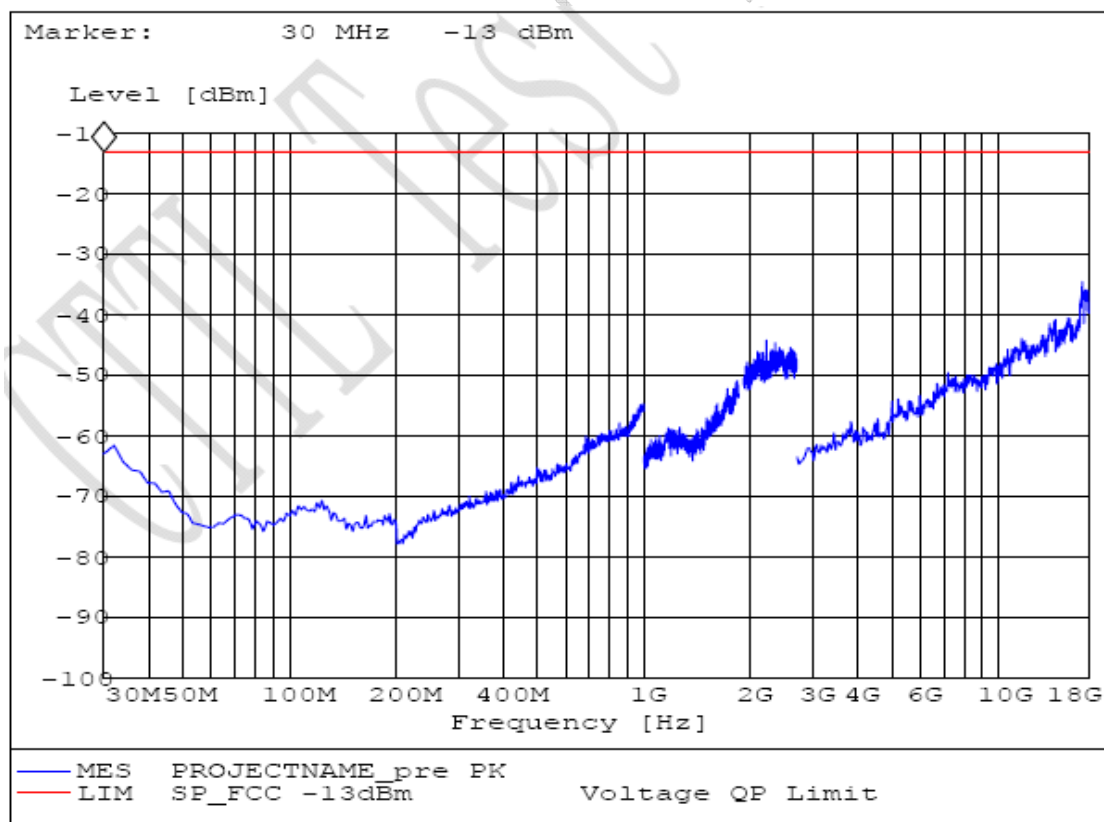

S661HF for GPRS mode

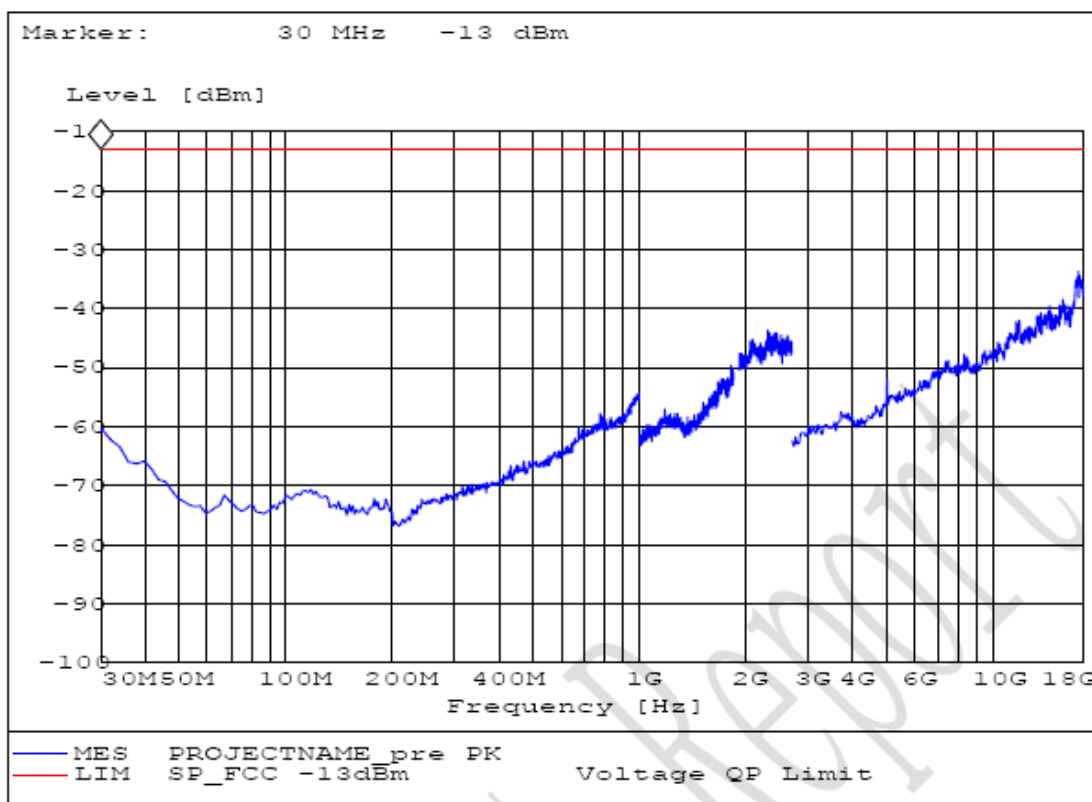

S661VT for GPRS mode

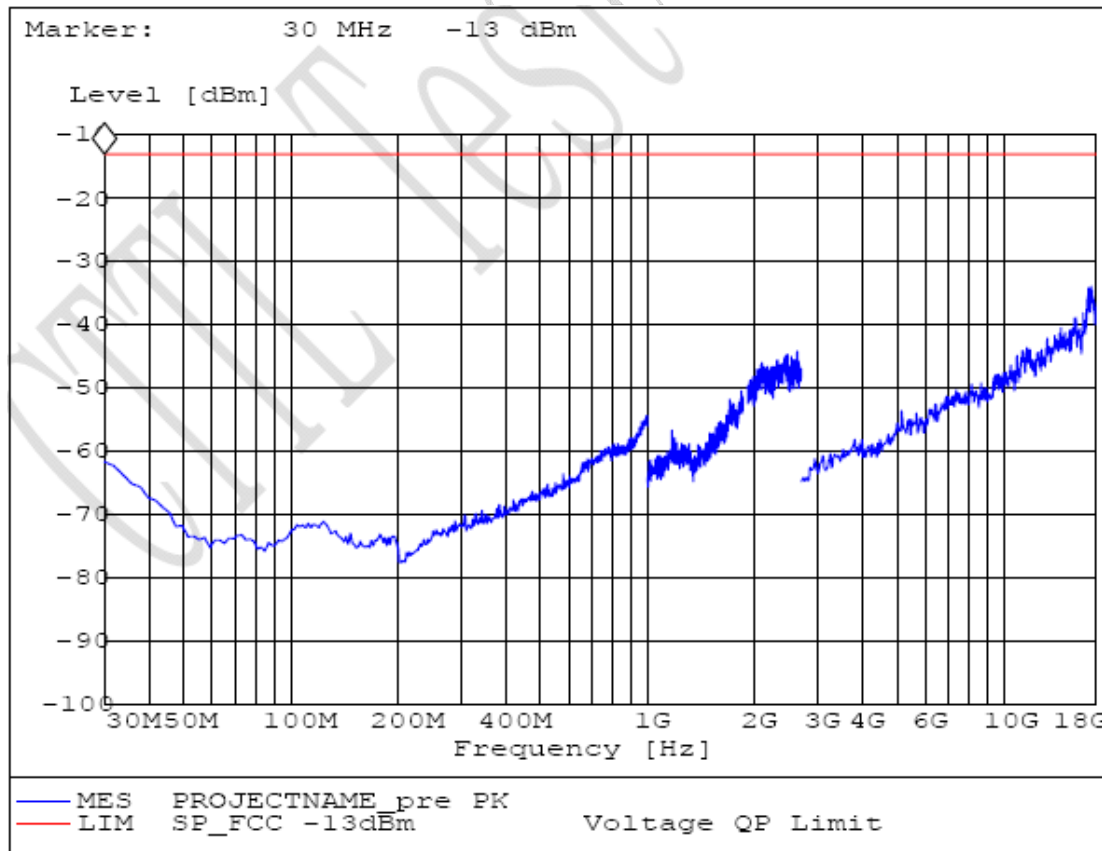

S661HT for GPRS mode

Test Results for EGPRS mode:

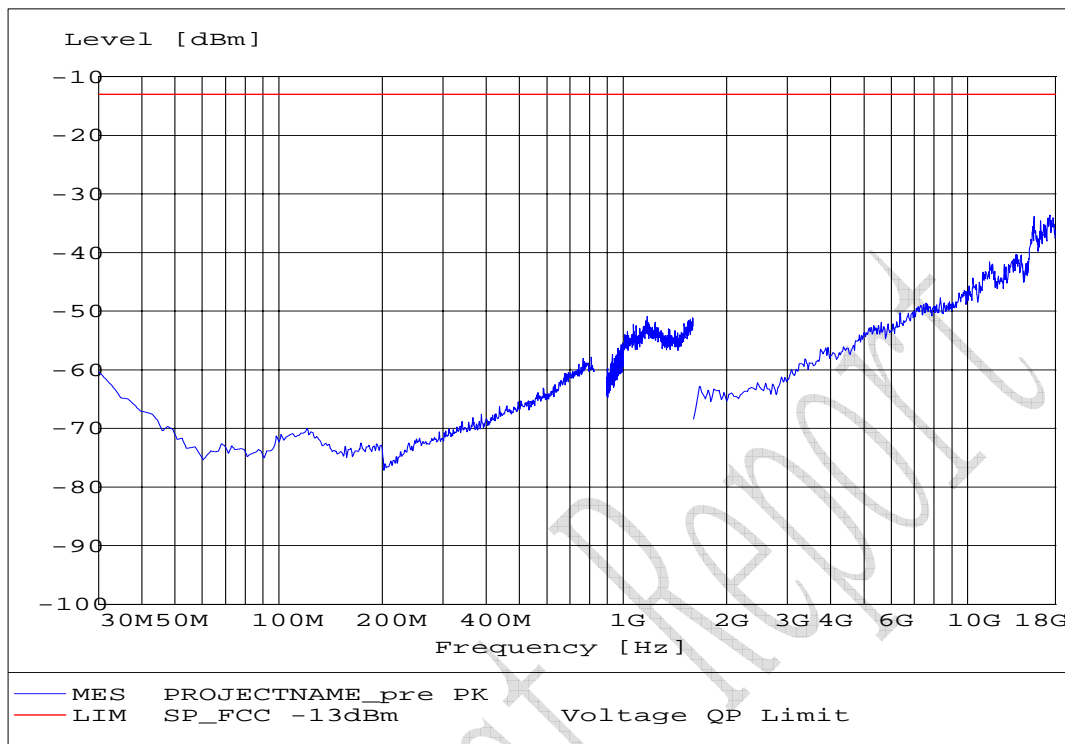

S190VF for EGPRS mode

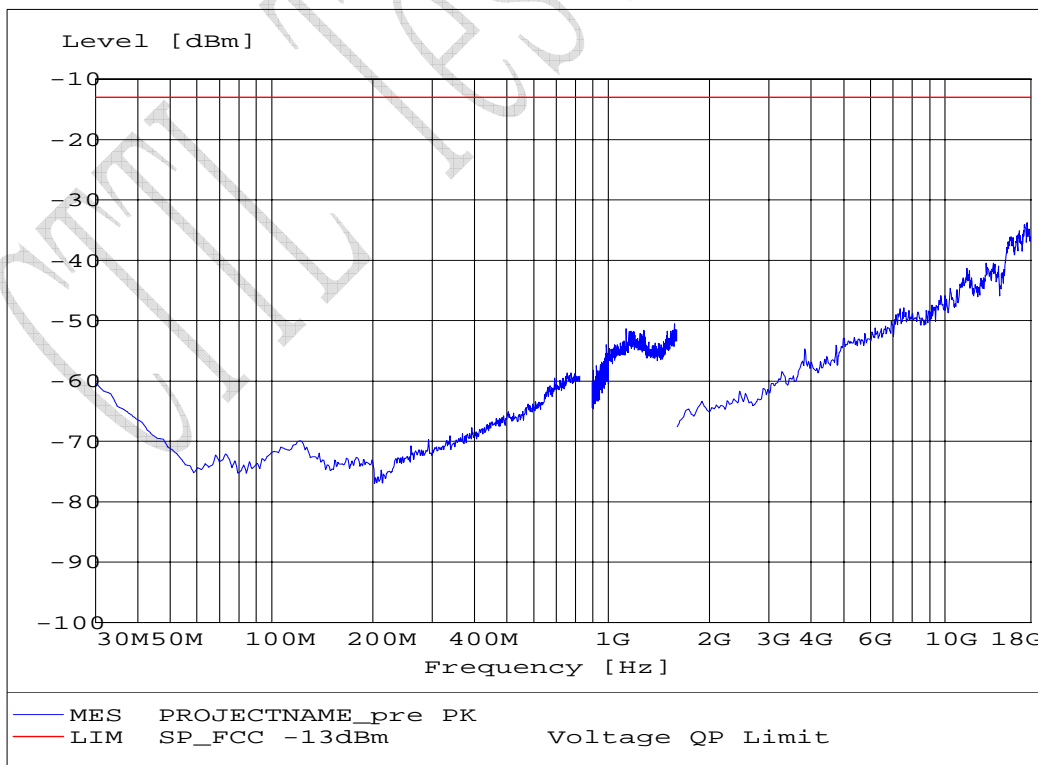

S190HF for EGPRS mode

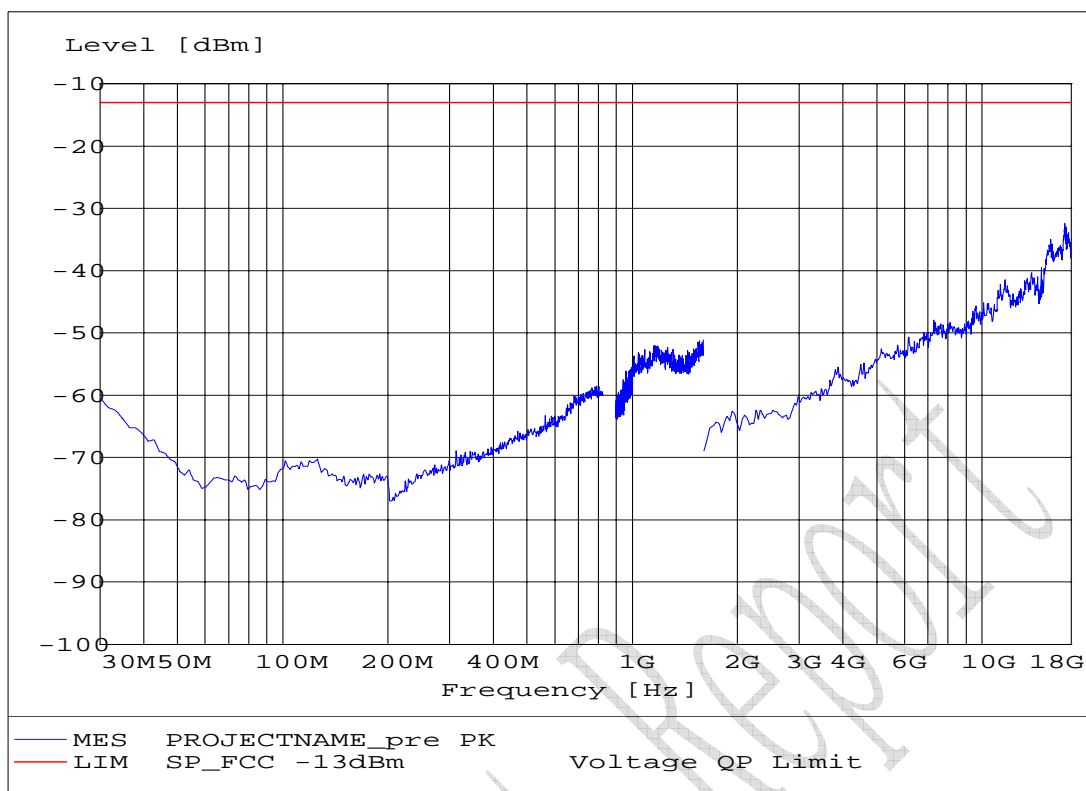

S190VT for EGPRS mode

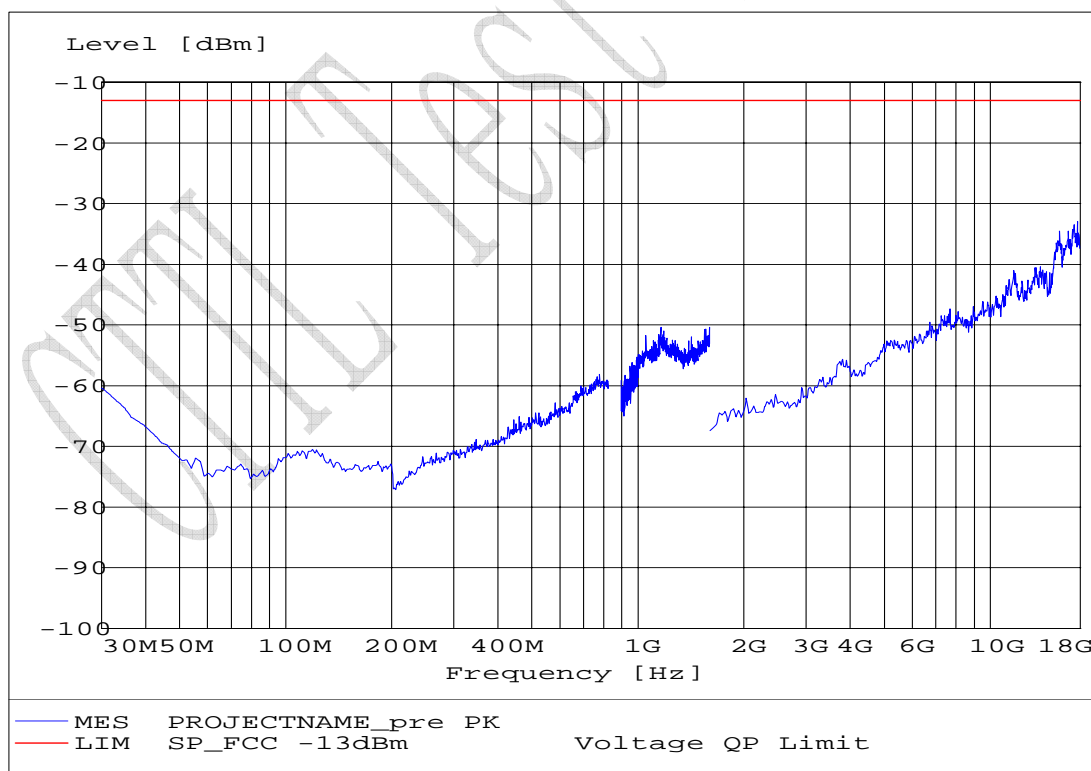

S190HT for EGPRS mode

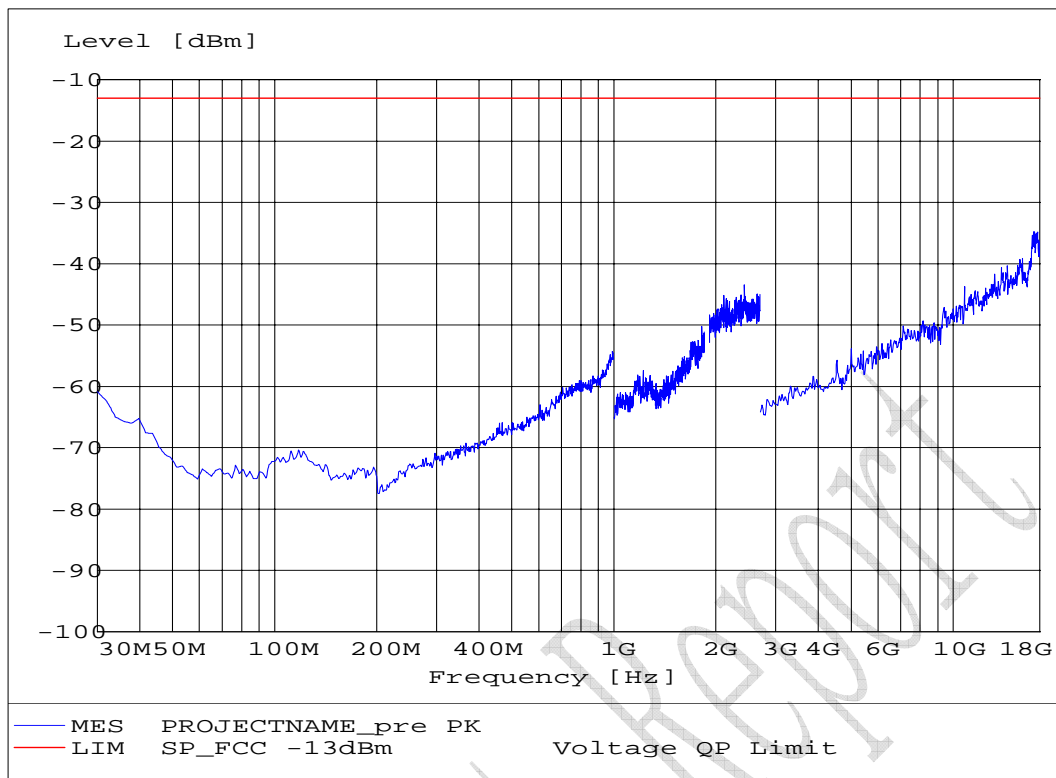

S661VF for EGPRS mode

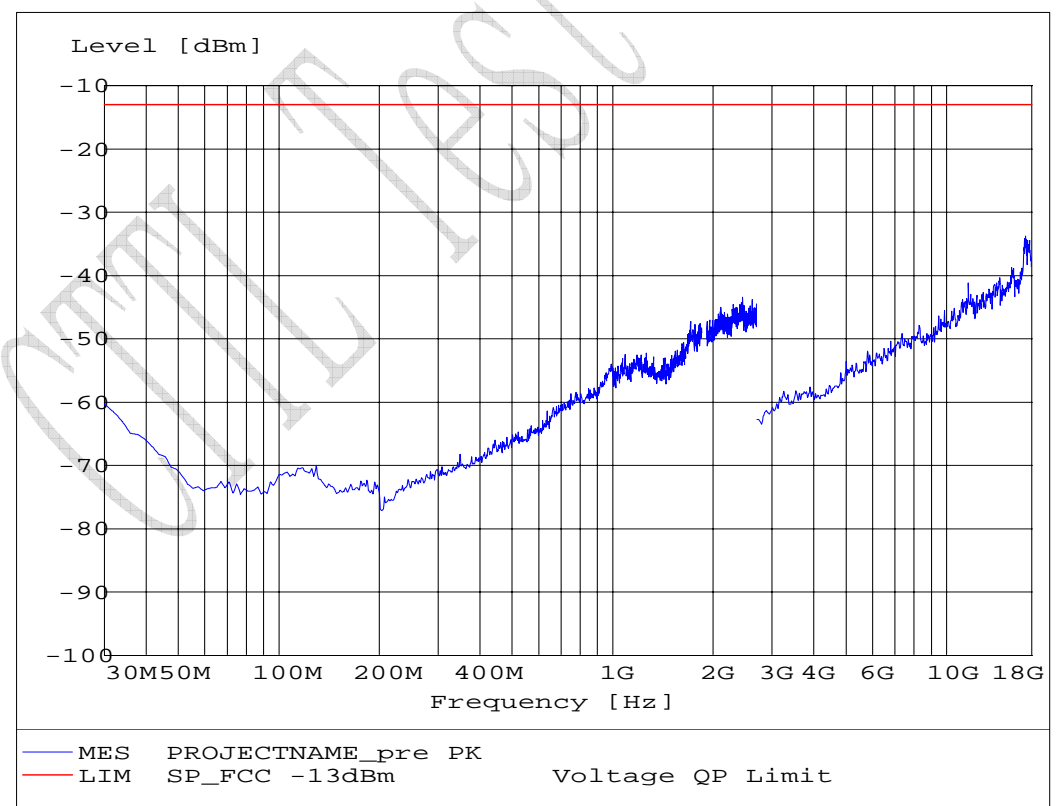

S661HF for EGPRS mode

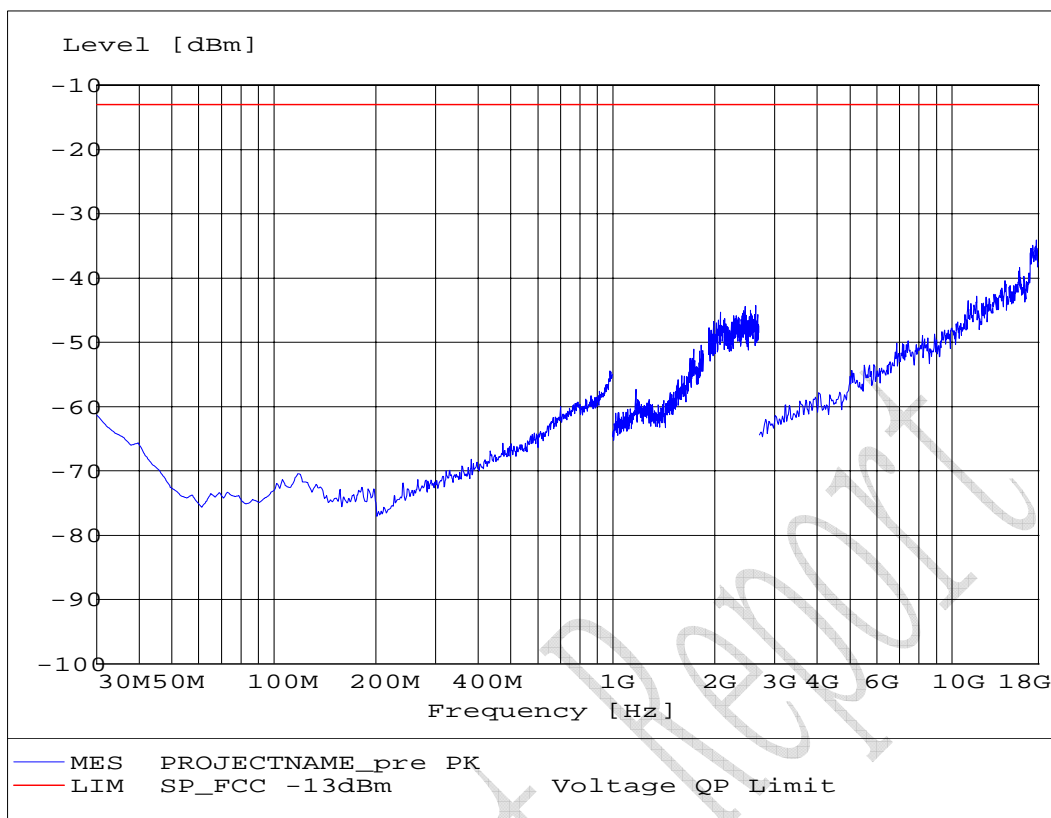

S661VT for EGPRS mode

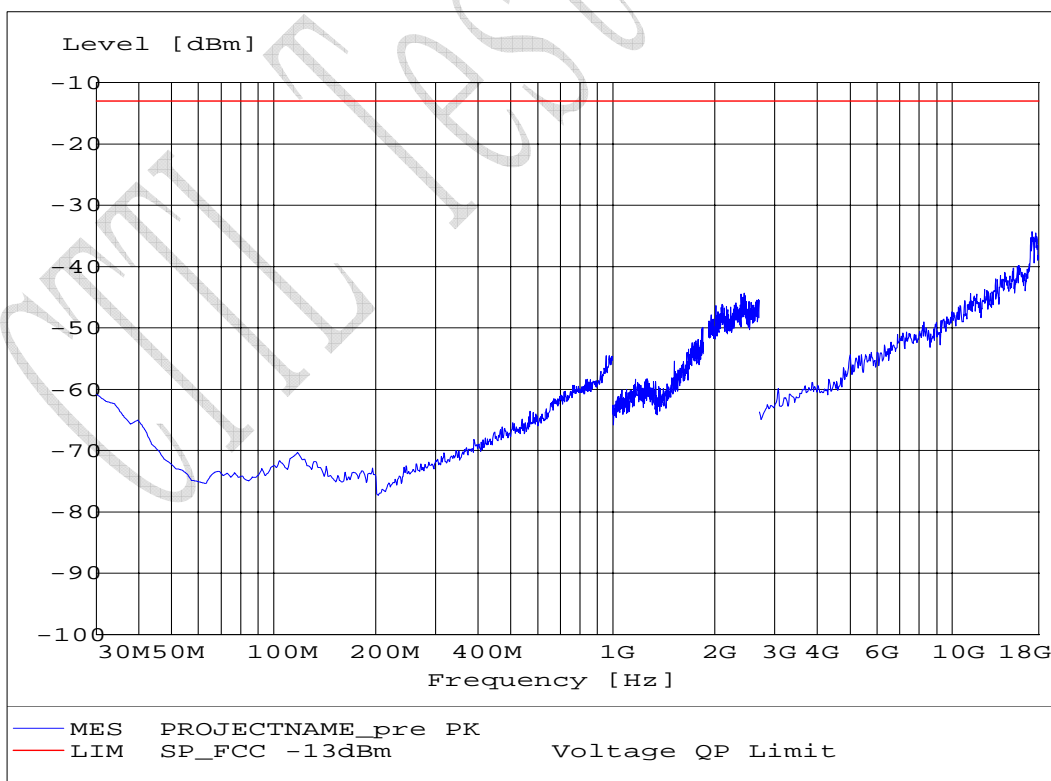

S661HT for EGPRS mode

Test Results for WCDMA mode:

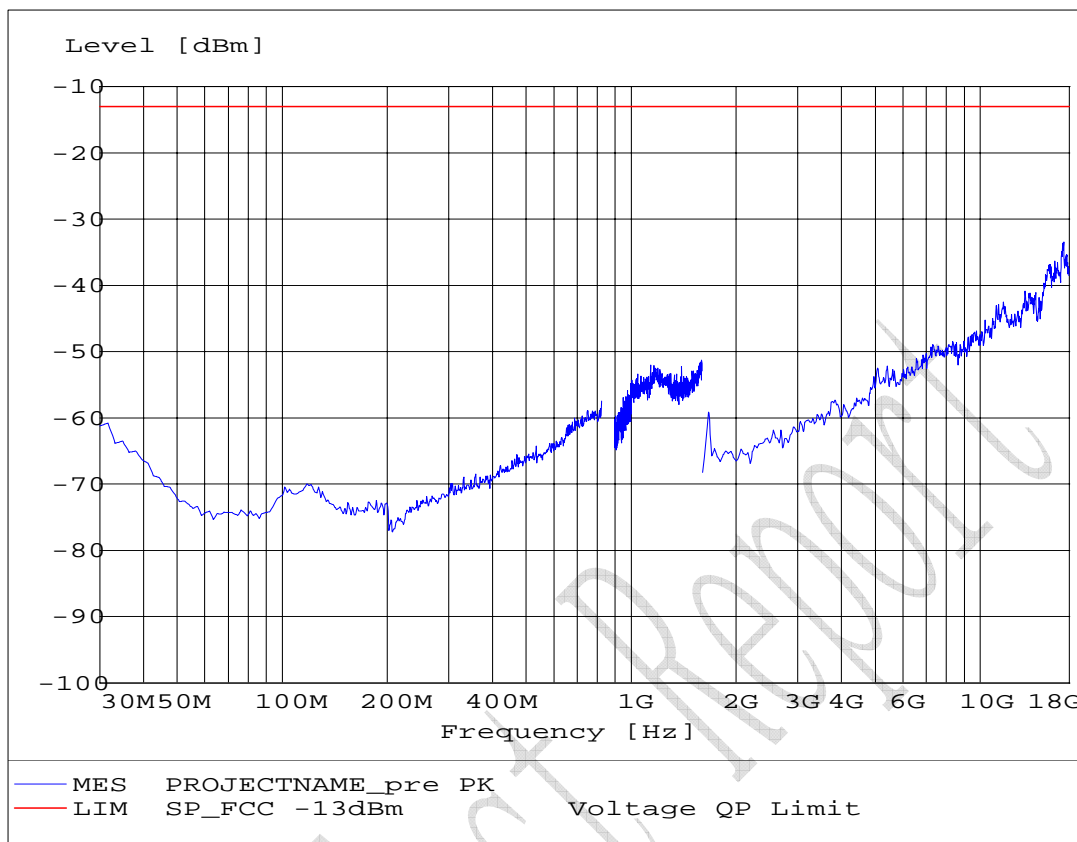

S4175VF for FDD V mode

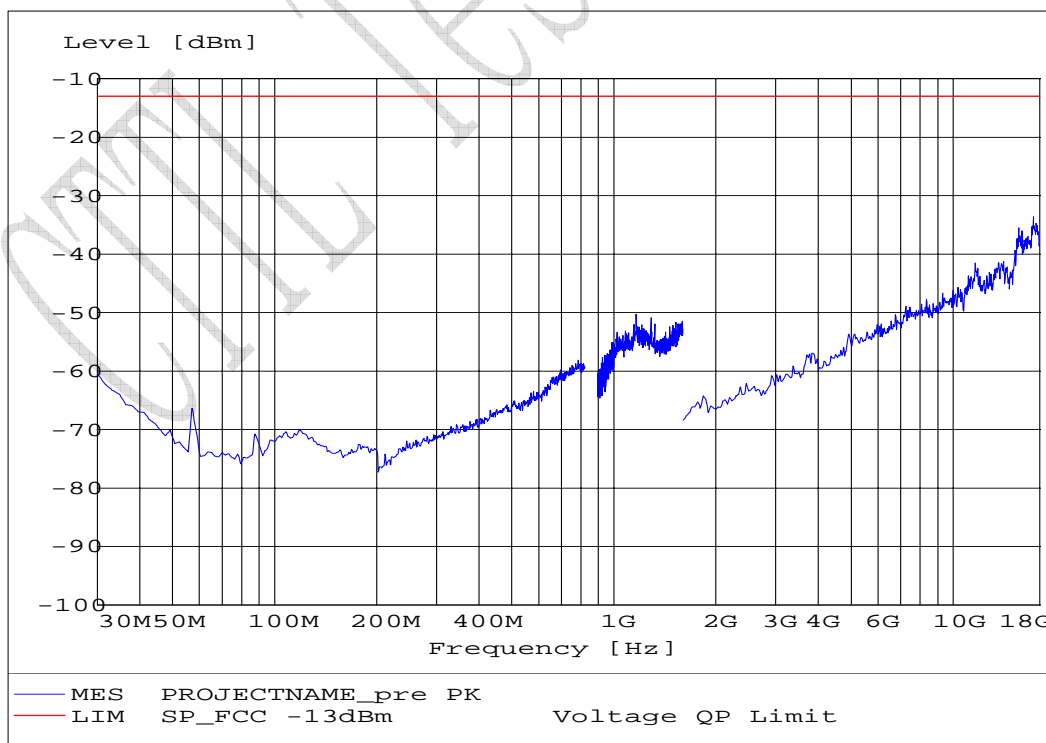

S4175HF for FDD V mode

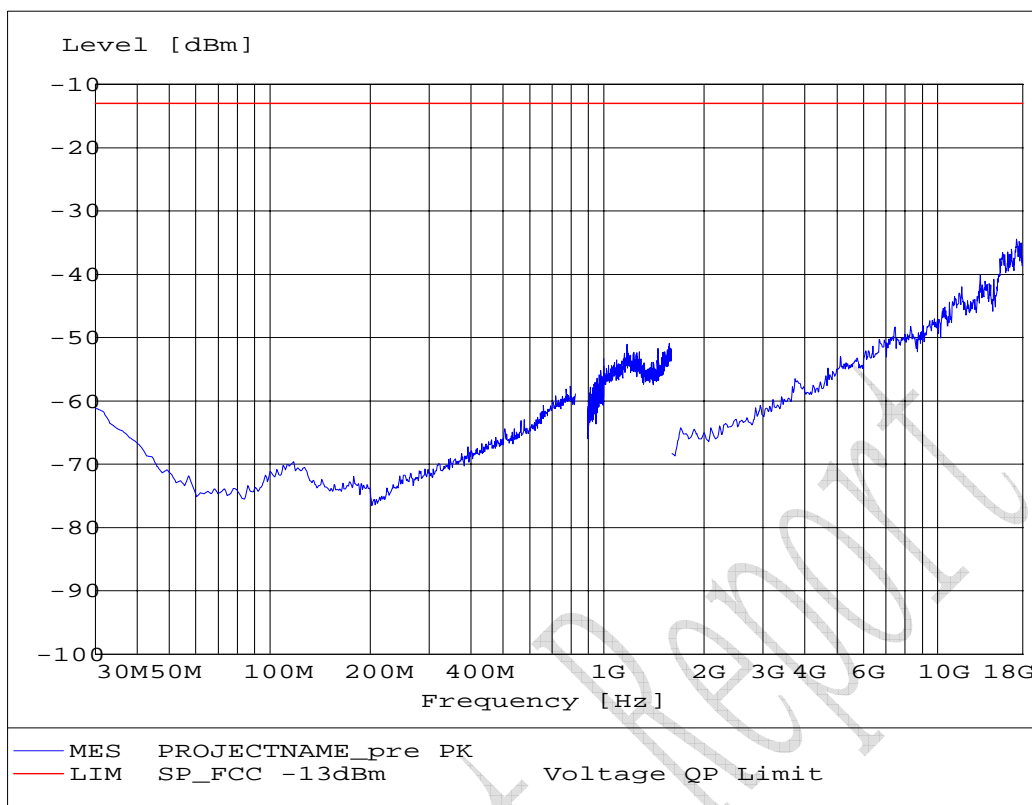

S4175VT for FDD V mode

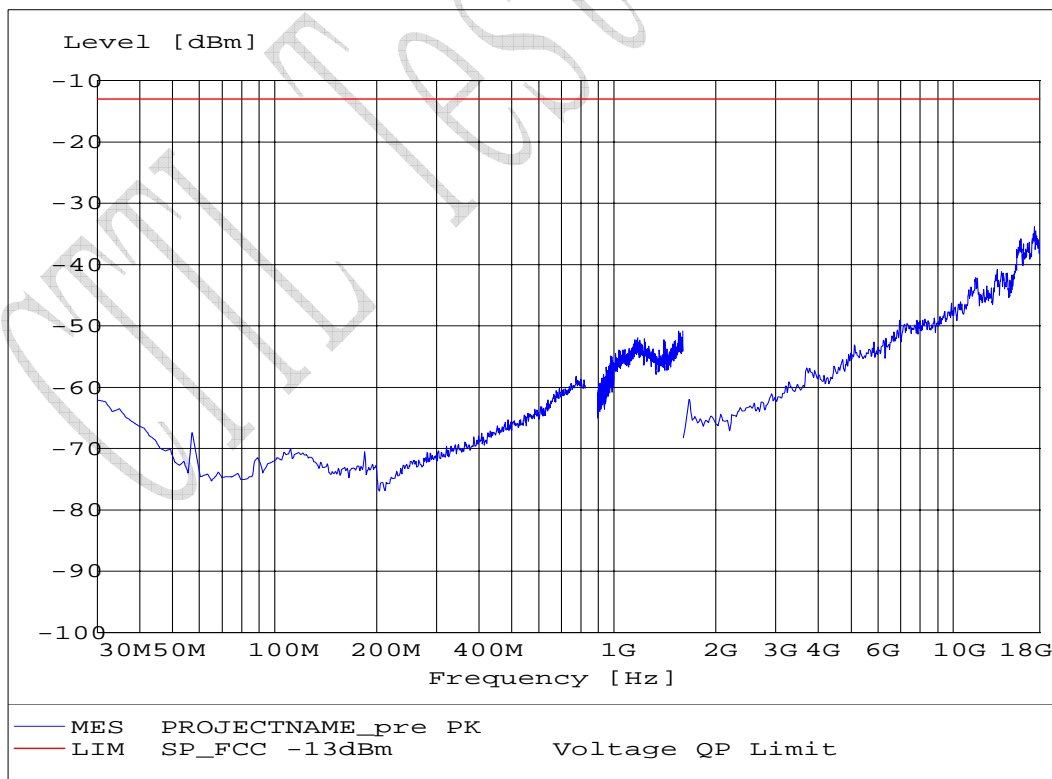

S4175HT for FDD V mode

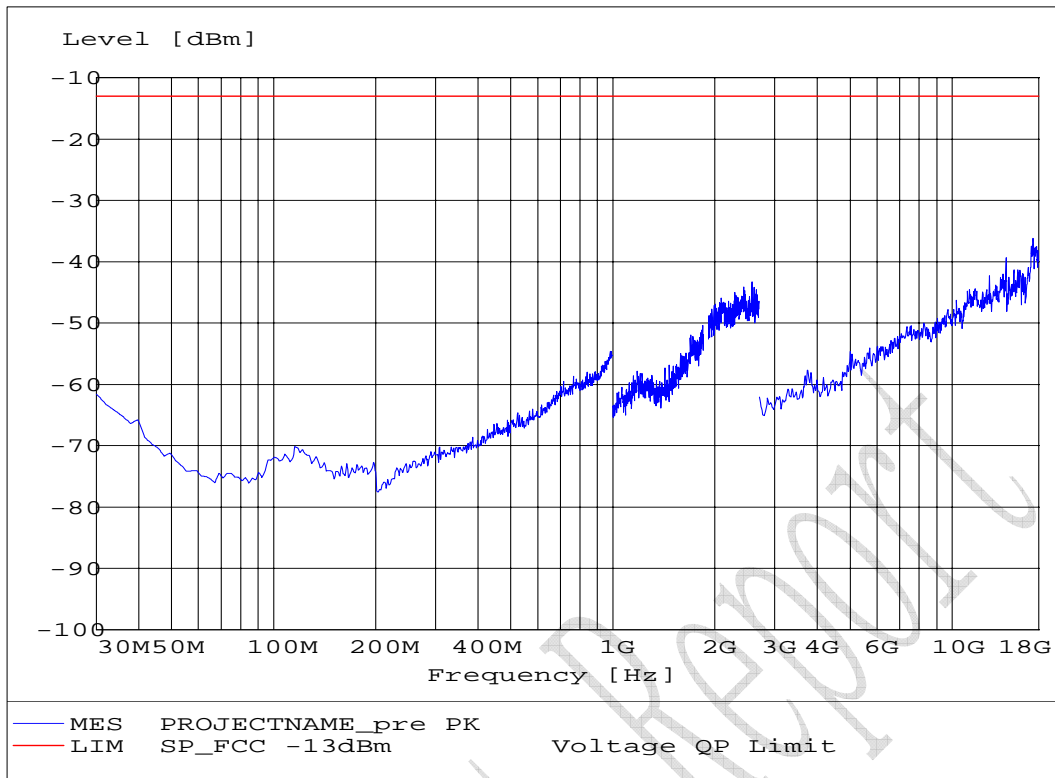

S9400VF for FDD II mode

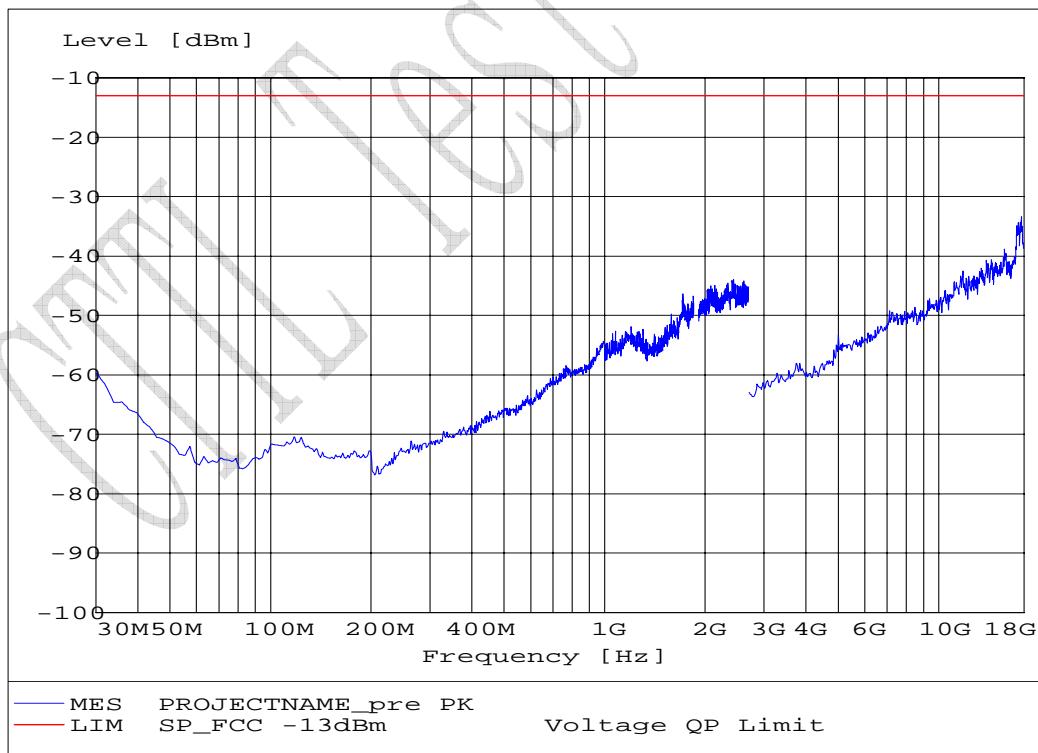

S9400HF for FDD II mode

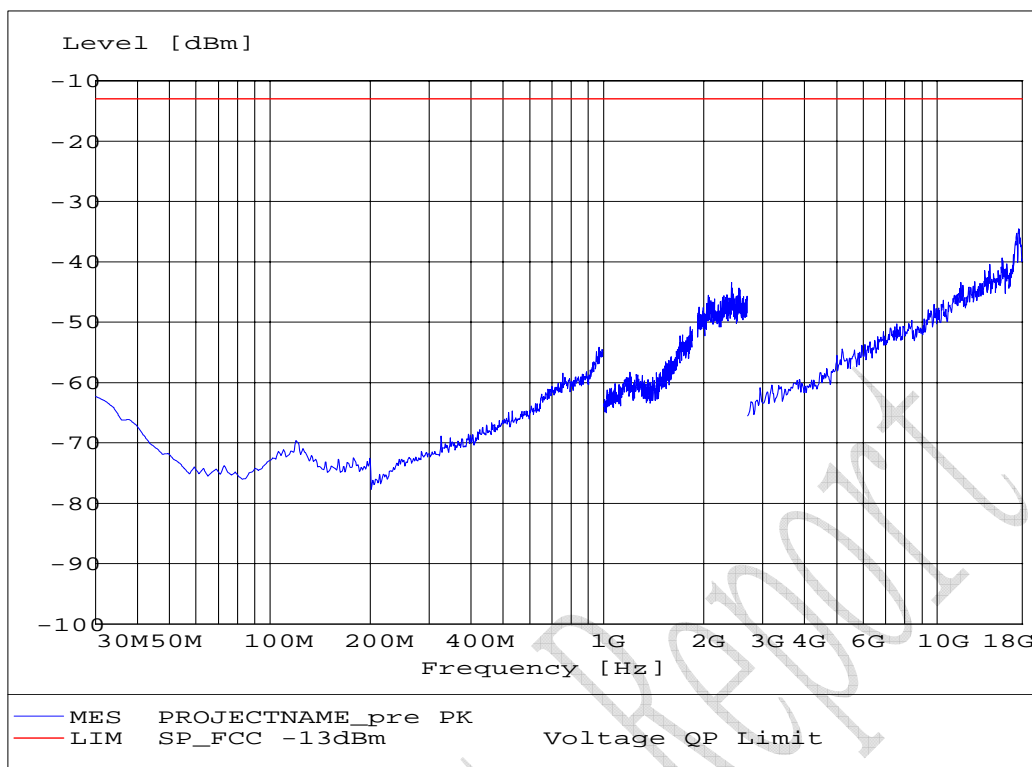

S9400VT for FDD II mode

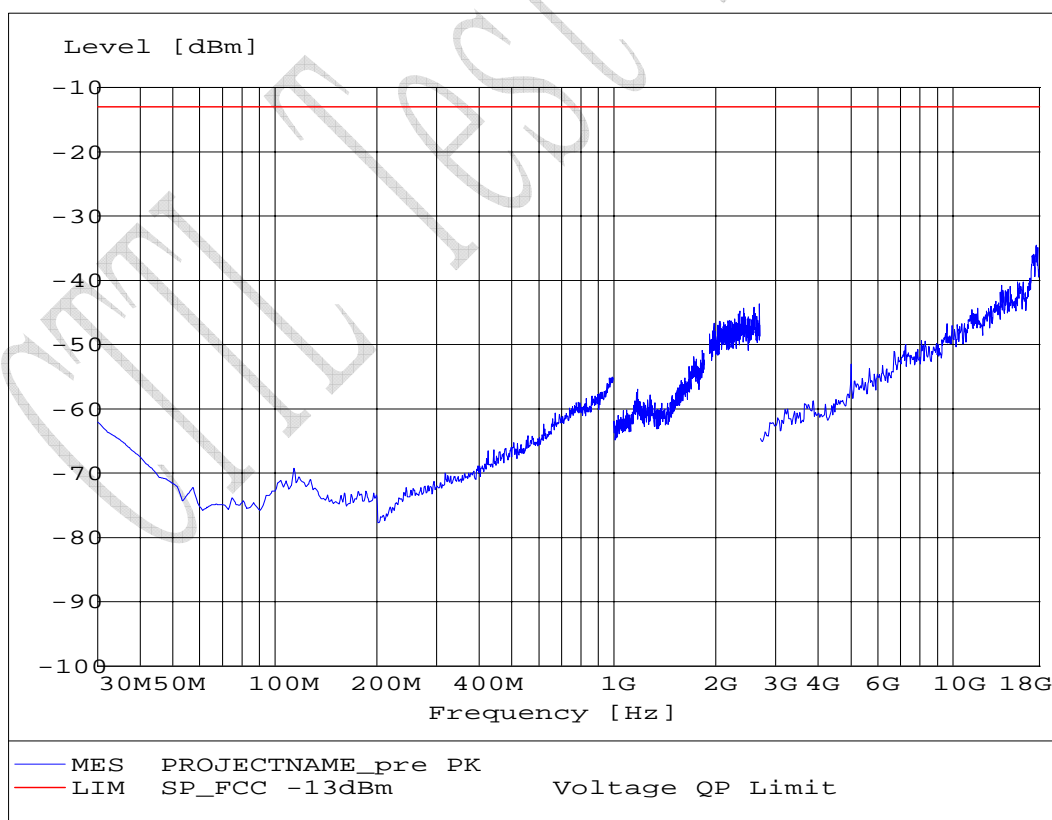

S9400HT for FDD II mode

4.2 Radiated RF Power Output and ERP

Specifications:	2.1046,24.232,22.913(a)					
Date of Tests	2009-9-16					
Test conditions:	Ambient Temperature: 15°C-35°C Relative Humidity: 30%-60% Air pressure: 86-106kPa					
Operation Mode	TX on, channel128, 190, 251, 512, 661 and 810 for GPRS and EGPRS; channel 4133, 4175, 4232, 9263, 9400 and 9537 for WCDMA.					
Test Results:	Pass					
Test equipment Used:						
Asset Number	Description	Manufacturer	Model Number	Serial Number	Cal Due	State
7805	EMI Test Receiver	R/S	ESI26	100211	2010-01-11	Normal
7330	Ultra Broadband Antenna	SCHWARZBECK	VULB 9160	--	2010-10-26	Normal
7330	Double-Ridged Horn Antenna	R/S	HF906	100037	2010-01-09	Normal
713	Fully-Anechoic Chamber	ETS	11.8m×6.5m×6.3m	--	2010-11-16	Normal
023	Wireless Communications Test Set	Agilent	8960(E5515C)	GB41450323	2010-06-09	Normal
111835	Wireless Communications Test Set	R&S	CMU200	1100000802	--	Normal

Limit Level Construction:

(a) Radiated RF Power Output

According to Part 24.232(b), i.e., Mobile/portable stations are limited to 2 watts EIRP peak power and the equipment must employ means to limit the power to the minimum necessary for successful communications, so the limit level is 2 W or 33 dBm.

(b) ERP

According to Part 22.913(a), the ERP of mobile transmitters and auxiliary test transmitters must not exceed 7 Watts.

Limits for Radiated RF Power Output	
Frequency range	Limit Level (EIRP)/Resolution Bandwidth
TX channel	33dBm/1MHz
Limits for ERP	
Frequency range	Limit Level (ERP)
TX channel	7W

Test Setup:

The EUT was set in an anechoic chamber, which is connected to the Wireless Communications Test Set located outside the chamber over the air. The test was done using an automated test system, where all test equipments were controlled by a computer.

Test Method

The measurement was performed accordance with section 2.2.17 of ANSI/TIA-603-B-2002: *Land Mobile FM or PM Communications Equipment Measurement and Performance Standards*.

1 The maximum power was searched by turning the azimuth of the turntable, shifting the polarization of the measuring antenna and changing the pose of the EUT.

2 The measured levels are EIRP values corrected in the automated test system with the correction factors given by a substitution calibration made before the measurement. The calibration is made separately for vertical and horizontal polarization and the system uses different correction factors depending on the measuring antenna polarization.

3 The corrected maximum levels were reported for EIRP values, and ERP values can be calculated from EIRP values.

Note:

ERP dBm = EIRP dBm – 2.15dB.

ERP Value for GPRS 850 band mode:

ARFCN	Frequency [MHz]	EIRP [dBm]
128	824.1282	21.78
190	836.6533	22.31
251	848.7776	19.47

EIRP Value for GPRS 1900 band mode:

ARFCN	Frequency [MHz]	EIRP [dBm]
512	1850.26052	20.33
661	1880.08016	20.30
810	1909.7394	20.70

ERP Value for EGPRS 850 band mode:

ARFCN	Frequency [MHz]	EIRP [dBm]
128	824.2284	25.29
190	836.6533	24.30
251	848.8777	23.09

EIRP Value for EGPRS 1900 band mode:

ARFCN	Frequency [MHz]	EIRP [dBm]
512	1850.2605	20.33
661	1880.0916	20.61
810	1909.7394	20.68

ERP Value for WCDMA FDD V band mode:

ARFCN	Frequency [MHz]	EIRP [dBm]
4133	827.2344	14.85
4175	835.5511	16.24
4232	845.5711	16.77

EIRP Value for WCDMA FDD II band mode:

ARFCN	Frequency [MHz]	EIRP [dBm]
9263	1853.9478	14.64
9400	1879.1182	13.88
9537	1908.1362	12.87

4.3 Occupied bandwidth

Specifications:	2.1049,22.917(b),24.238(b)					
Date of Test	2009-9-4/11/15					
Test conditions:	Ambient Temperature: 15°C-35°C Relative Humidity: 30%-60% Air pressure: 86-106kPa					
Operation Mode	TX on, channel128, 190, 251, 512, 661 and 810 for GPRS and EGPRS; channel 4133, 4175, 4232, 9263, 9400 and 9537 for WCDMA.					
Test Results:	--					
Test equipment Used:						
Asset Number	Description	Manufacturer	Model Number	Serial Number	Cal Due	State
7805	EMI Test Receiver	R/S	ESI26	100211	2010-01-11	Normal
7330	Ultra Broadband Antenna	SCHWARZBECK	VULB 9160	--	2010-10-26	Normal
7330	Double-Ridged Horn Antenna	R/S	HF906	100037	2010-01-09	Normal
713	Fully-Anechoic Chamber	ETS	11.8m×6.5m×6.3m	--	2010-11-16	Normal
023	Wireless Communications Test Set	Agilent	8960(E5515C)	GB41450323	2010-06-09	Normal
111835	Wireless Communications Test Set	R&S	CMU200	1100000802	--	Normal

Test Setup

During the process of testing, the EUT was controlled via Wireless Communications Test Set to ensure max power transmission and proper modulation and measured by Rhode & Schwarz EMI test receiver (ESI26)

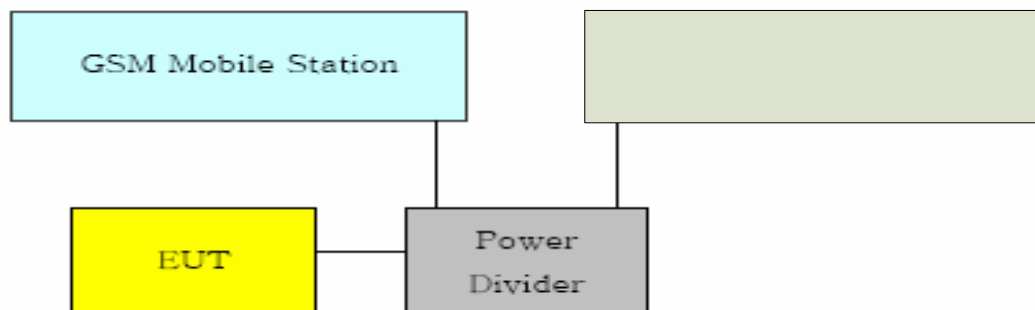

Test Method

The 99% occupied bandwidth was calculated from the spectrum analyzer.

Markers in the spectrum analyzer were then placed between the calculated frequencies to show the calculated 99% power band.

Note:

--

Results data of GPRS mode:

EUT channel	99% occupied bandwidth [kHz]
128	248.49
190	244.49
251	252.40
512	240.48
661	248.49
810	244.49

Graphical results for GPRS mode:

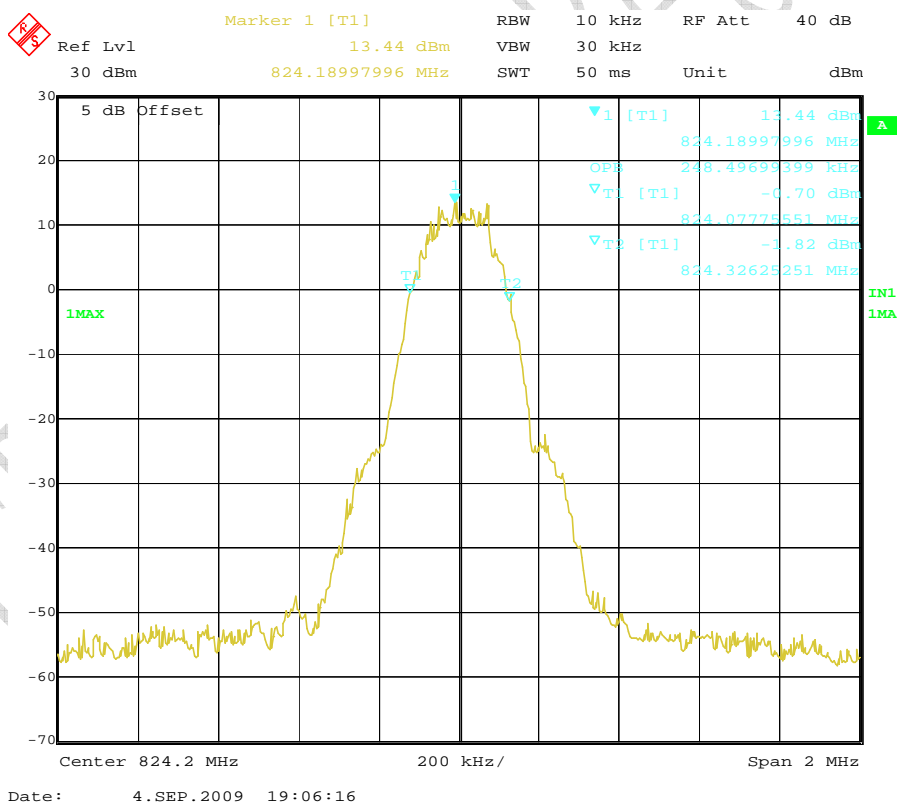

Channel 128

FCC Parts 2, 22, 24
Equipment: MC8795V

REPORT NO.: I09GW6944-FCC-EMC-3

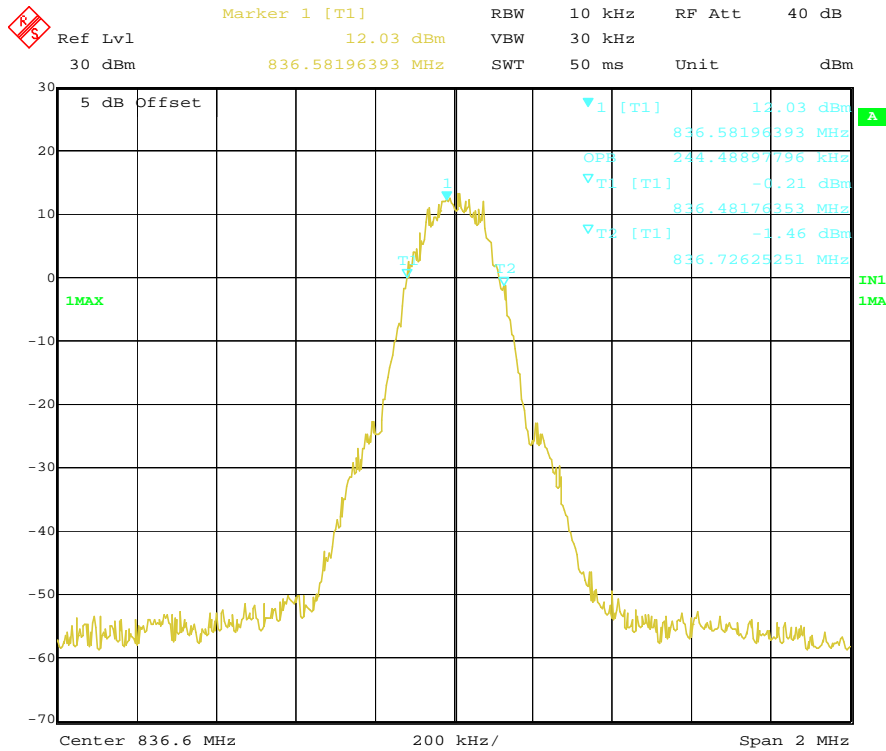

Date: 4.SEP.2009 19:08:04

Channel 190

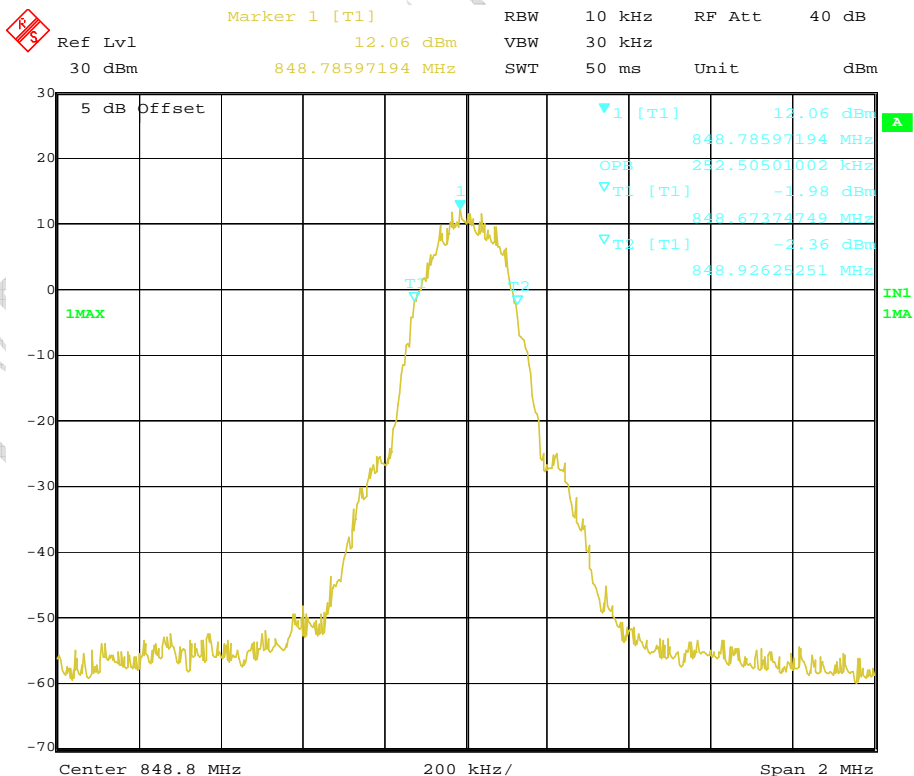

Date: 4.SEP.2009 19:09:29

Channel 251

FCC Parts 2, 22, 24
Equipment: MC8795V

REPORT NO.: I09GW6944-FCC-EMC-3

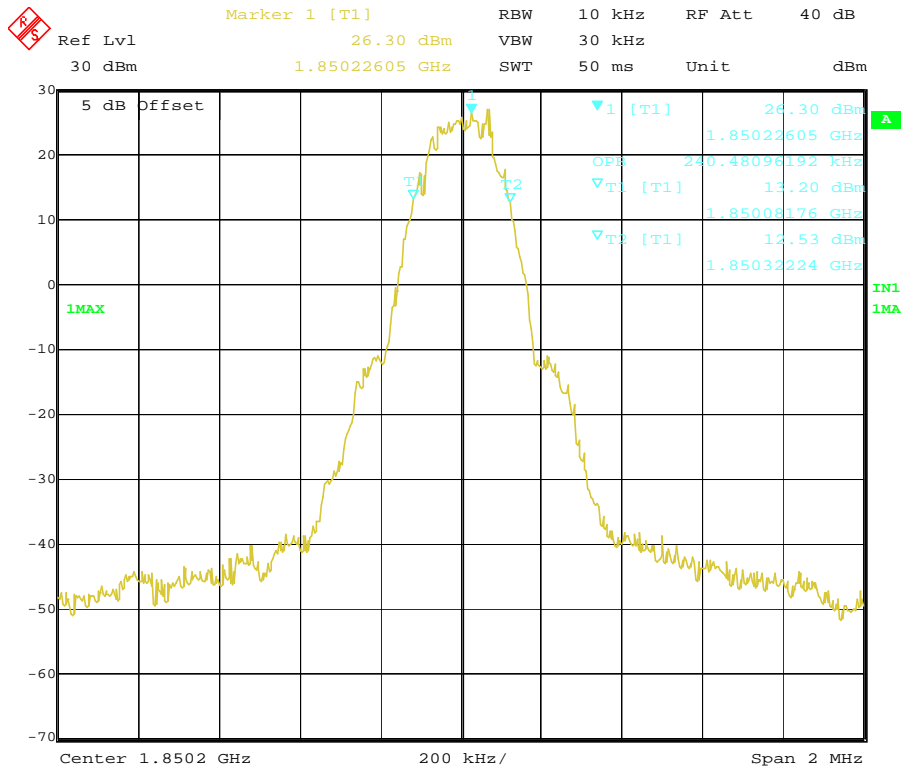

Date: 4.SEP.2009 19:12:19

Channel 512

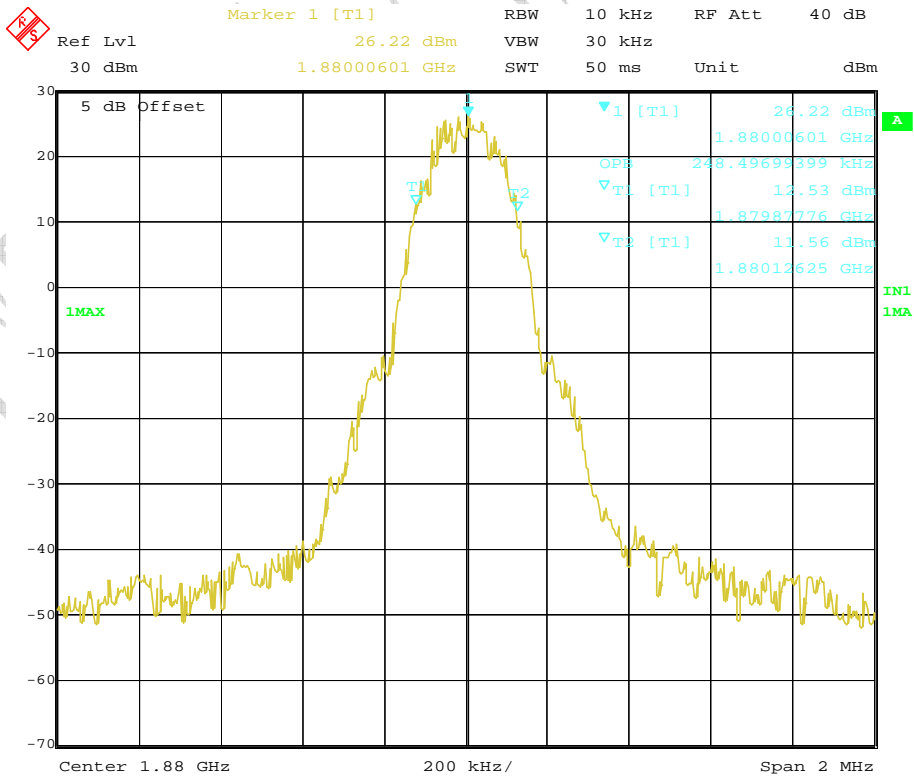

Date: 4.SEP.2009 19:16:26

Channel 661

FCC Parts 2, 22, 24
Equipment: MC8795V

REPORT NO.: I09GW6944-FCC-EMC-3

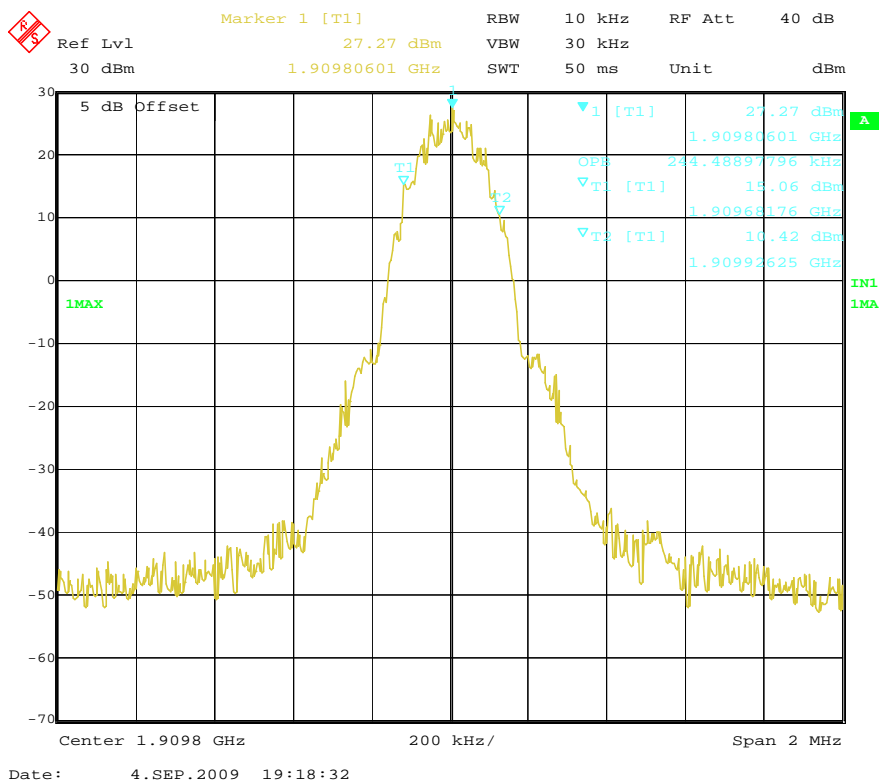

Channel 810

Results data of EGPRS mode:

EUT channel	99% occupied bandwidth [kHz]
128	244.48
190	248.49
251	244.48
512	244.48
661	240.49
810	244.48

Graphical results for EGPRS mode:

FCC Parts 2, 22, 24
Equipment: MC8795V

REPORT NO.: I09GW6944-FCC-EMC-3

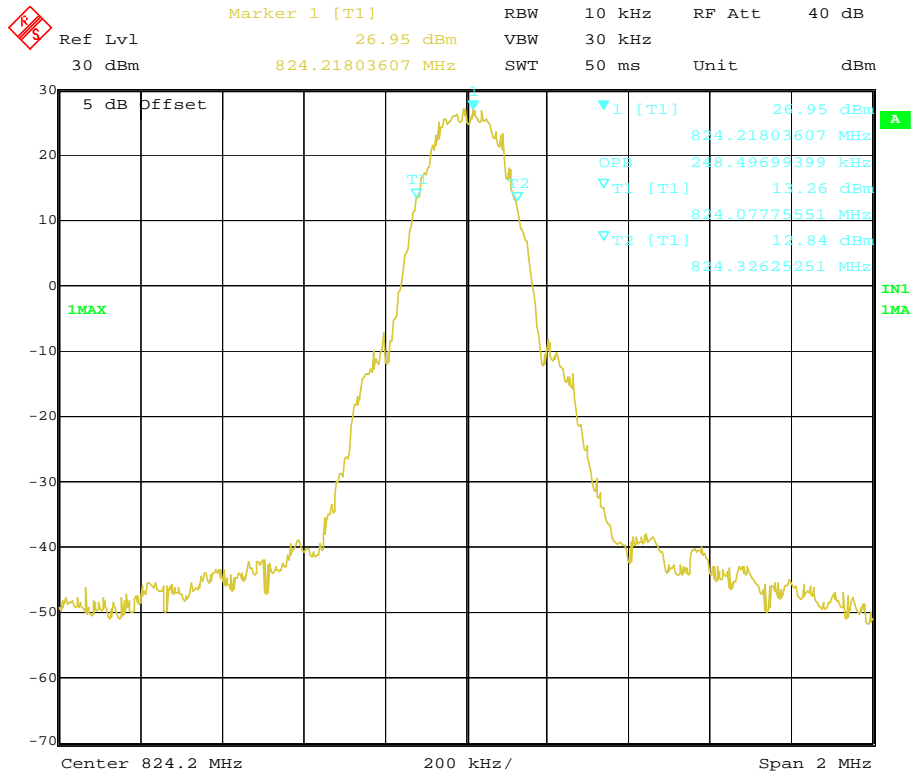

Date: 4.SEP.2009 19:25:58

Channel 128

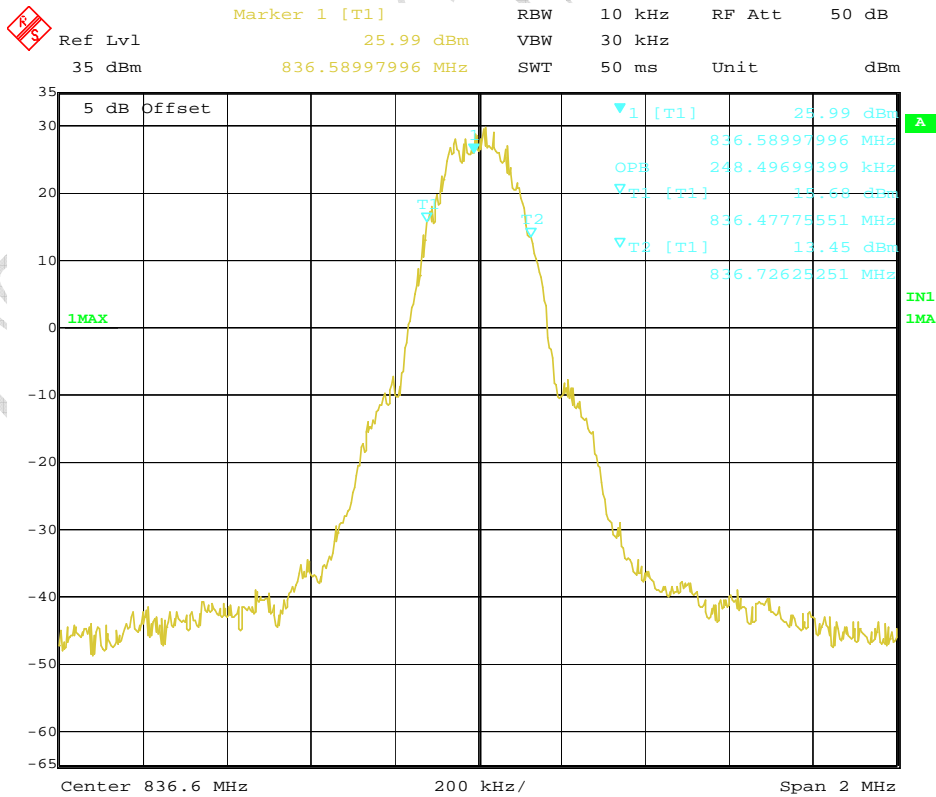

Date: 4.SEP.2009 19:30:51

Channel 190

FCC Parts 2, 22, 24
Equipment: MC8795V

REPORT NO.: I09GW6944-FCC-EMC-3

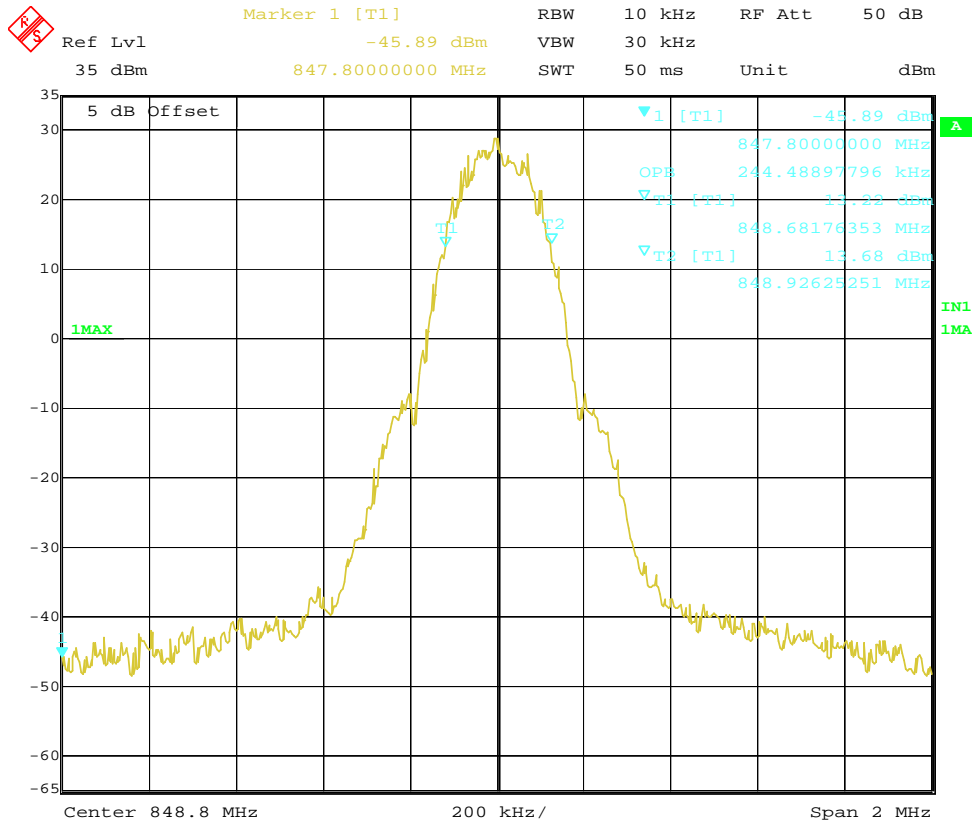

Date: 4.SEP.2009 19:32:55

Channel 251

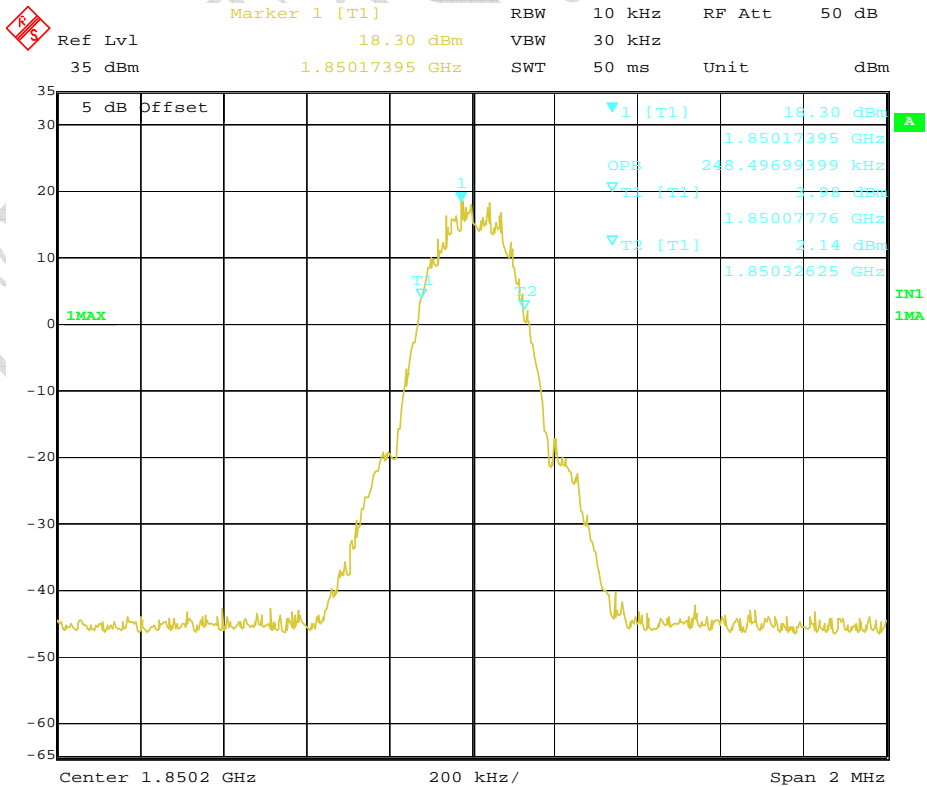

Date: 4.SEP.2009 19:35:18

Channel 512

FCC Parts 2, 22, 24
Equipment: MC8795V

REPORT NO.: I09GW6944-FCC-EMC-3

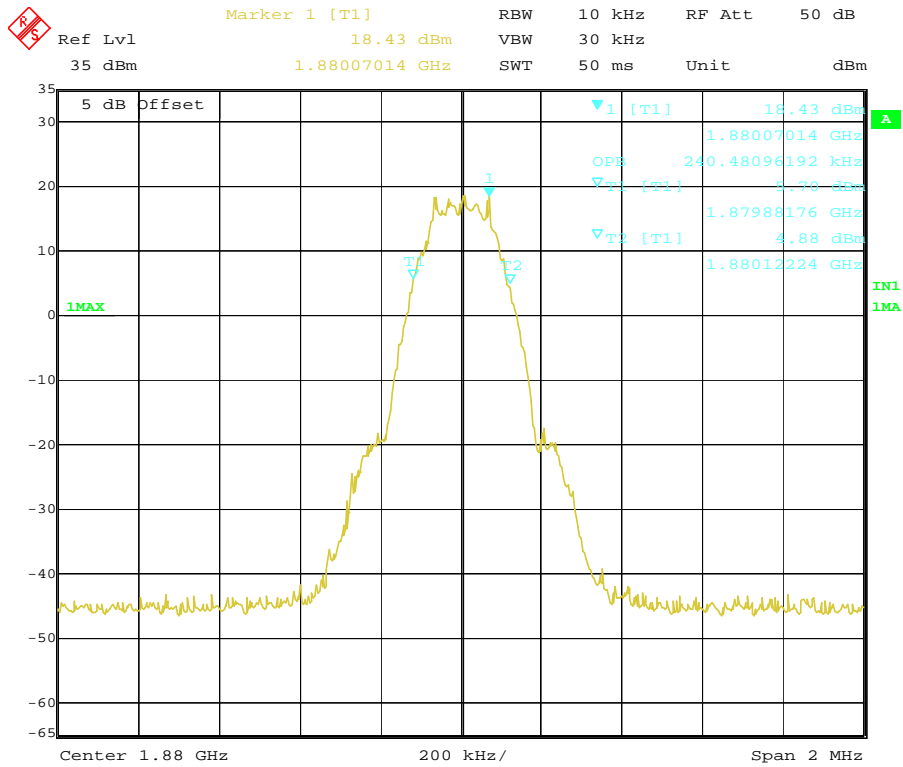

Channel 661

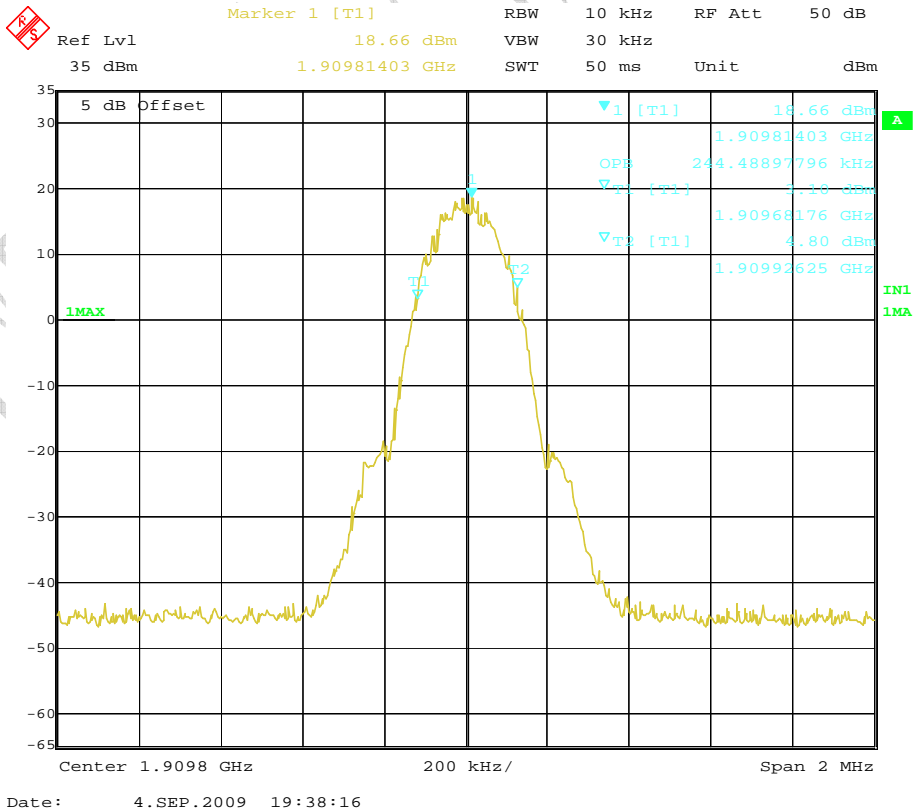

Channel 810

Results data of WCDMA mode:

EUT channel	99% occupied bandwidth [MHz]
4133	4.188
4175	4.168
4232	4.168
9263	4.208
9400	4.208
9537	4.208

Graphical results for WCDMA mode:

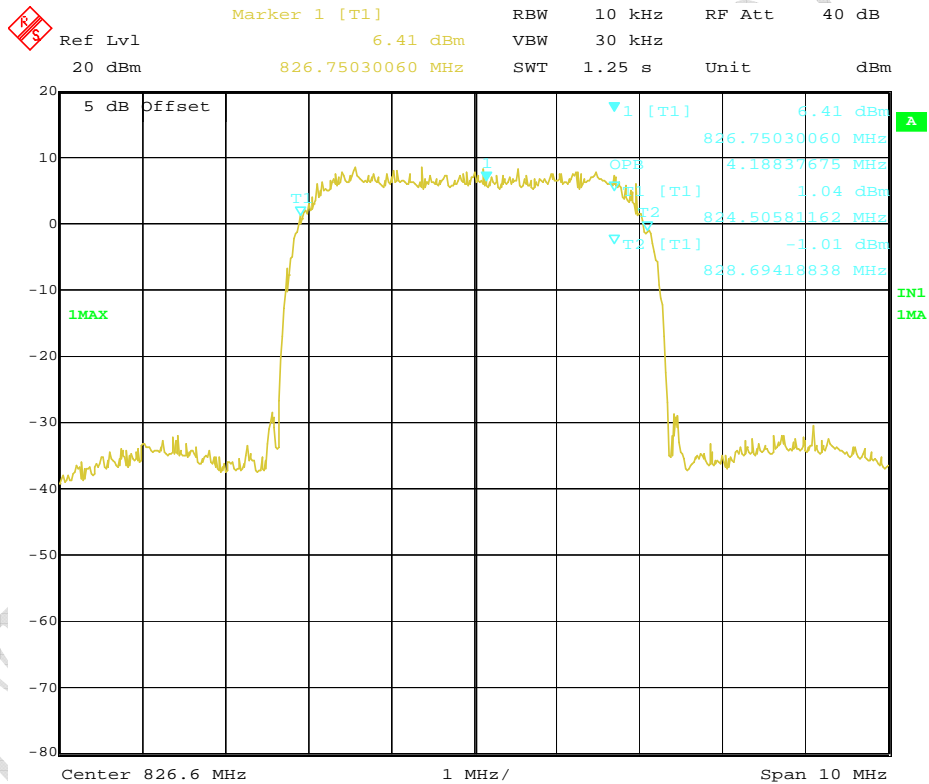

Date: 11.SEP.2009 18:37:42

Channel 4133

FCC Parts 2, 22, 24
Equipment: MC8795V

REPORT NO.: I09GW6944-FCC-EMC-3

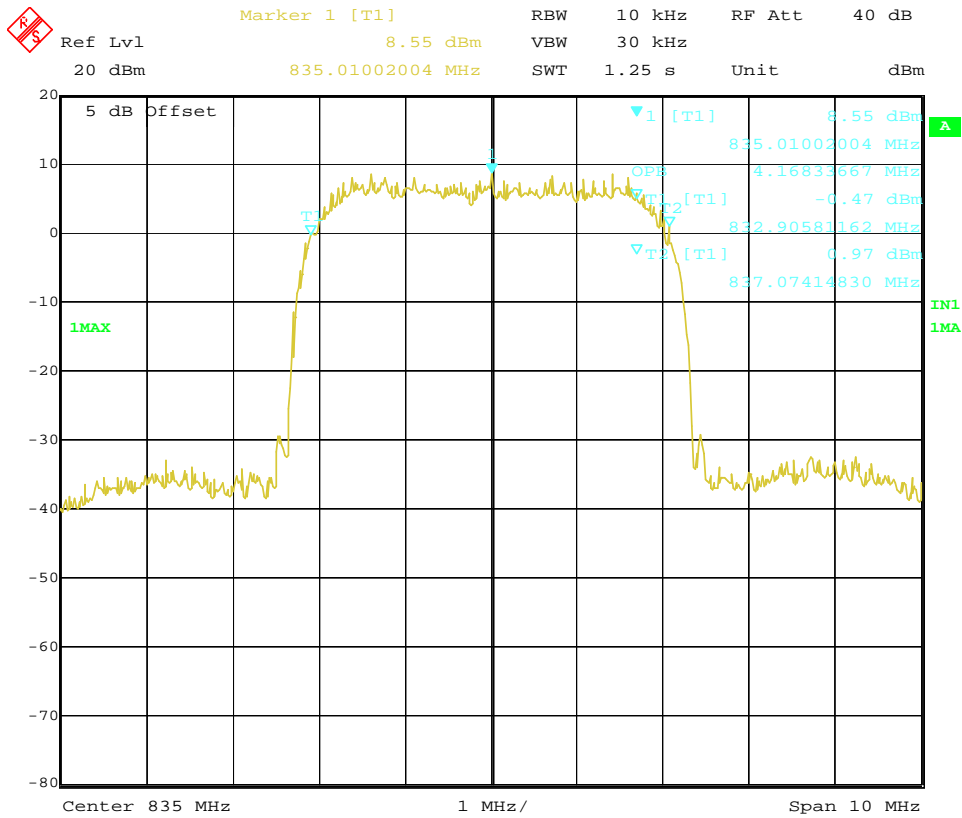

Date: 11.SEP.2009 18:39:56

Channel 4175

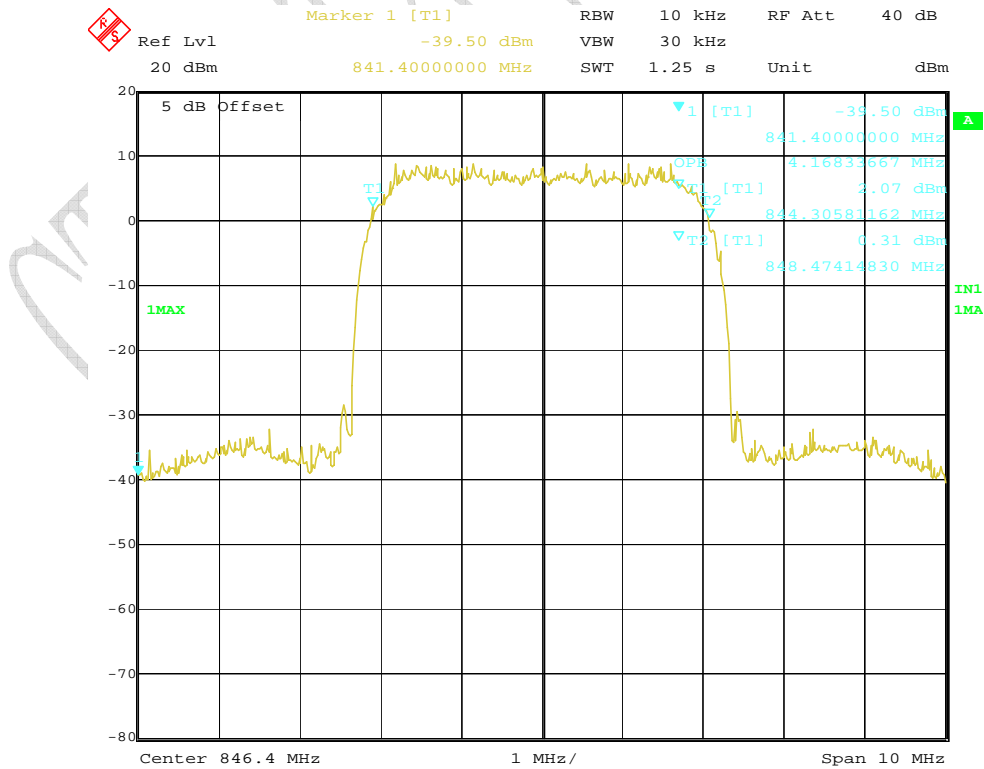

Date: 11.SEP.2009 18:45:12

Channel 4232

FCC Parts 2, 22, 24
Equipment: MC8795V

REPORT NO.: I09GW6944-FCC-EMC-3

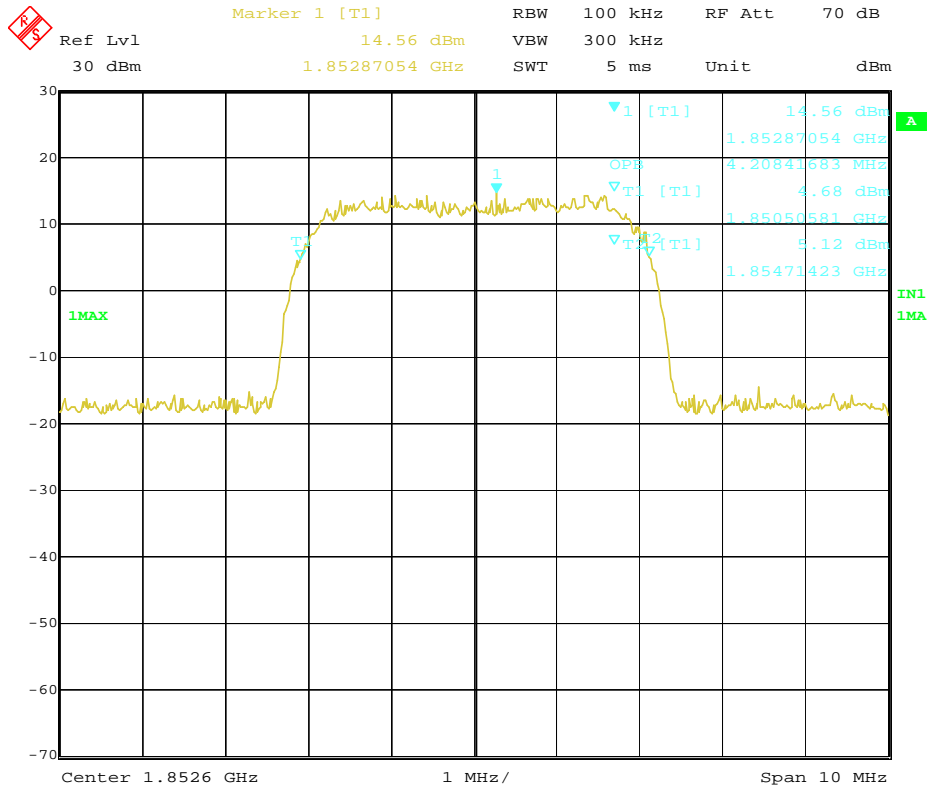

Channel 9263

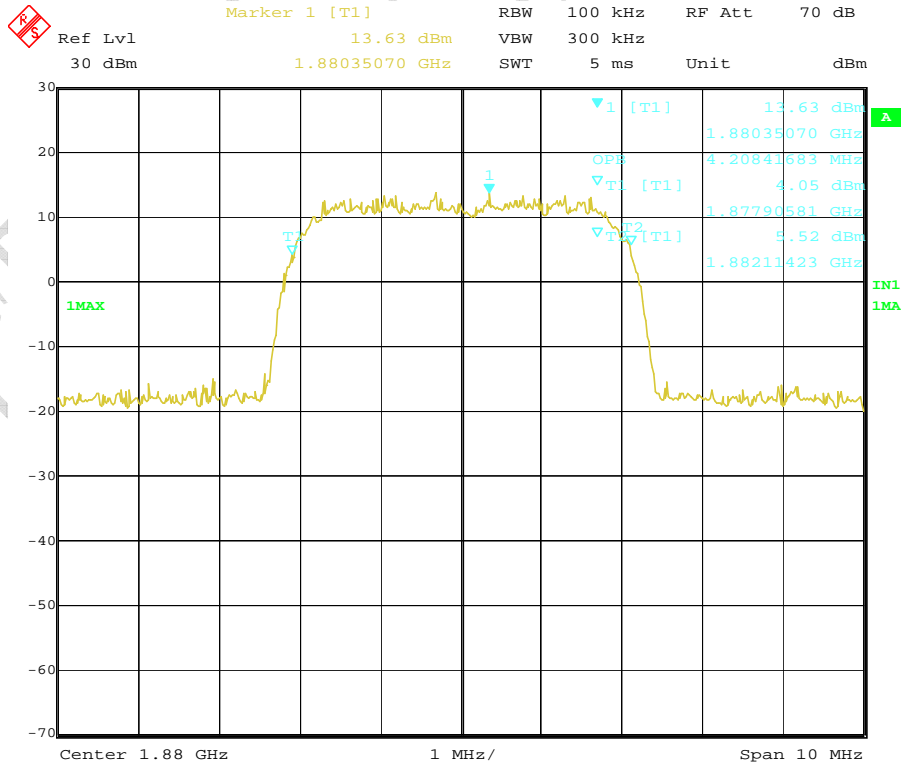

Channel 9400

FCC Parts 2, 22, 24
Equipment: MC8795V

REPORT NO.: I09GW6944-FCC-EMC-3

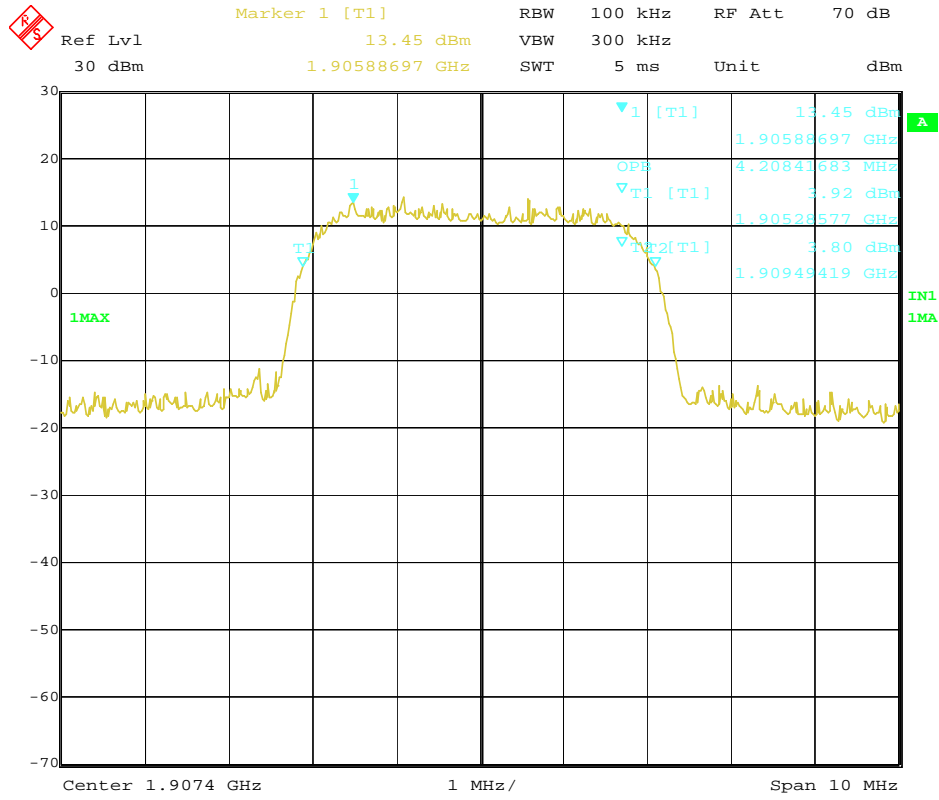

Date: 15.SEP.2009 12:32:19

Channel 9537

TTL TEST

4.4 Frequency Stability over Temperature Variation

Specifications:	2.1055,22.355,24.235					
Date of Test	2009-9-11/15					
Test conditions:	Ambient Temperature: -30°C-50°C Relative Humidity: 30%-60% Air pressure: 86-106kPa					
Operation Mode	TX on, channel 190 and 661 for GPRS and EGPRS, and 4175 and 9400 for WCDMA					
Test Results:	Pass					
Test equipment Used:						
Asset Number	Description	Manufacturer	Model Number	Serial Number	Cal Due	State
023	Wireless Communications Test Set	Agilent	8960(E5515C)	GB41450323	2010-06-09	Normal
561	Temperature Chamber	Terchy Environmental Technology LTD.	MHU-800SR	84121202	2011-01-06	Normal
111835	Wireless Communications Test Set	R&S	CMU200	1100000802	--	Normal
Limit						
Frequency deviation [ppm]	±2.5					

Test Setup

The EUT was placed in a temperature chamber, demonstrated as figure T. The wireless communications test set (test simulator) was used to set the TX channel and power levels, modulate the TX signal with different bit patterns and measure the frequency of TX.

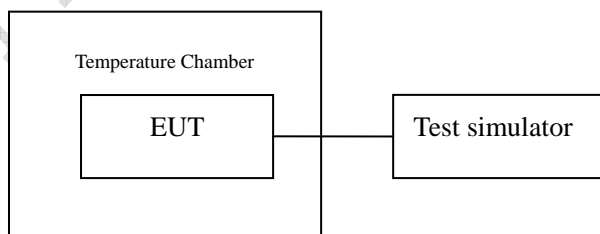

Figure T: setup for measurement of frequency stability over temperature variation

Test Method

1. The EUT was turned off and placed in the temperature chamber.
2. The temperature of the chamber was set to -30°C and allowed to stabilize.
3. The EUT temperature was allowed to stabilize for 45 minutes.
4. The EUT was turned on and set to transmit with 8960.
5. The maximum transmit frequency deviation during one minute period was measured by Wireless Communications Test Set.
6. The steps 3-5 were repeated for -20°C, -10°C, 0°C, 10°C, 20°C, 30°C, 40°C and 50°C.

Test results data for GPRS mode:

Channel 190: Compliance windows: 2091.5Hz

Temperature[°C]	Deviation[Hz]	Remarks
-30	25	Pass
-20	20	Pass
-10	18	Pass
0	25	Pass
10	23	Pass
20	30	Pass
30	18	Pass
40	23	Pass
50	17	Pass

Channel 661: Compliance windows: 4700Hz

Temperature[°C]	Deviation[Hz]	Remarks
-30	19	Pass
-20	23	Pass
-10	20	Pass
0	8	Pass
10	5	Pass
20	9	Pass
30	6	Pass
40	8	Pass
50	15	Pass

Test results data for EGPRS mode:

Channel 190: Compliance windows: 2091.5Hz

Temperature[°C]	Deviation[Hz]	Remarks
-30	27	Pass
-20	25	Pass
-10	18	Pass
0	28	Pass
10	21	Pass
20	33	Pass
30	30	Pass
40	-2	Pass
50	-7	Pass

Channel 661: Compliance windows: 4700Hz

Temperature[°C]	Deviation[Hz]	Remarks
-30	23	Pass
-20	18	Pass
-10	19	Pass
0	10	Pass
10	8	Pass
20	3	Pass
30	6	Pass
40	10	Pass
50	17	Pass

Test results data for WCDMA mode:

Channel 4175: Compliance windows: 2087.5Hz

Temperature[°C]	Deviation[Hz]	Remarks
-30	-33	Pass
-20	-22	Pass
-10	-21	Pass
0	-24	Pass
10	-26	Pass
20	-22	Pass
30	-23	Pass
40	-22	Pass
50	-23	Pass

Channel 661: Compliance windows: 4700Hz

Temperature[°C]	Deviation[Hz]	Remarks
-30	-26	Pass
-20	-37	Pass
-10	-34	Pass
0	-38	Pass
10	-32	Pass
20	-36	Pass
30	-44	Pass
40	-26	Pass
50	-46	Pass

4.5 Frequency Stability over Voltage Variation

Specifications:	2.1055,22.355,24.235					
Date of Test	2009-9-11/15					
Test conditions:	Ambient Temperature: 15°C-35°C Relative Humidity: 30%-60% Air pressure: 86-106kPa					
Operation Mode	TX on, channel 190 and 661 for GPRS and EGPRS, and 4175 and 9400 for WCDMA					
Test Results:	Pass					
Test equipment Used:						
Asset Number	Description	Manufacturer	Model Number	Serial Number	Cal Due	State
023	Wireless Communications Test Set	Agilent	8960(E5515C)	GB41450323	2010-06-09	Normal
7982	DC Power Source	4NIC	DH1715A-3	004224	--	Normal
Limit						
Frequency deviation [ppm]	±2.5					

Test Setup

The EUT was placed in a shielding chamber and powered by the dummy battery which is connected to a DC power source, demonstrated as figure V. The wireless communications test set was used to set the TX channel and power level, modulate the TX signal with different bit patterns and measure the frequency of TX.

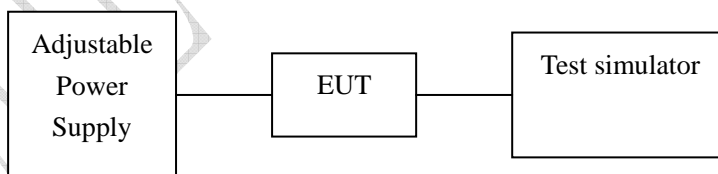

Figure V: test setup for measurement of frequency stability over voltage variation

Test Results data for GPRS mode:

Channel 190: Compliance windows: 2091.5Hz

Level	Voltage[V]	Deviation[Hz]	Remarks
Nominal	3.3	23	Pass
Cut-off point	3.0	25	Pass

Channel 661: Compliance windows: 4700Hz

Level	Voltage[V]	Deviation[Hz]	Remarks
Nominal	3.3	23	Pass
Cut-off point	3.0	25	Pass

Test Results data for EGPRS mode:

Channel 190: Compliance windows: 2091.5Hz

Level	Voltage[V]	Deviation[Hz]	Remarks
Nominal	3.3	21	Pass
Cut-off point	3.0	24	Pass

Channel 661: Compliance windows: 4700Hz

Level	Voltage[V]	Deviation[Hz]	Remarks
Nominal	3.3	28	Pass
Cut-off point	3.0	29	Pass

Test Results data for WCDMA mode:

Channel 4175: Compliance windows: 2087.5Hz

Level	Voltage[V]	Deviation[Hz]	Remarks
Nominal	3.3	22	Pass
Cut-off point	3.0	-209	Pass

Channel 9400: Compliance windows: 4700Hz

Level	Voltage[V]	Deviation[Hz]	Remarks
Nominal	3.3	49	Pass
Cut-off point	3.0	-187	Pass

4.6 Conducted RF Power Output

Specifications:	2.1046,22.913(a),24.232(c)					
Date of Tests	2009-9-11/14, 2009-11-26					
Test conditions:	Ambient Temperature: 15°C-35°C Relative Humidity: 30%-60% Air pressure: 86-106kPa					
Operation Mode	TX on, channel 128, 190, 251 and 512, 661, 810 for GPRS and EGPRS, and 4132, 4175, 4233 and 9262, 9400, 9538 for WCDMA					
Test Results:	Pass					
Test equipment Used:						
Asset Number	Description	Manufacturer	Model Number	Serial Number	Cal Due	State
7805	EMI Test Receiver	R/S	ESI26	100211	2010-01-11	Normal
023	Wireless Communications Test Set	Agilent	8960(E5515C)	GB41450323	2010-06-09	Normal
---	Power splitter	Jie sai	---	1000132	2010-01-04	Normal
111835	Wireless Communications Test Set	R&S	CMU200	1100000802	--	Normal

Limits for Radiated RF Power Output	
Frequency range	Limit Level (EIRP)/Resolution Bandwidth
TX channel	33dBm/1MHz
Limits for ERP	
Frequency range	Limit Level (ERP)
TX channel	7W

Test Setup:

During the process of testing, the EUT was controlled via the Wireless Communications Test Set to ensure max power transmission and proper modulation and measured by Rhode & Schwarz EMI test receiver (ESI26).

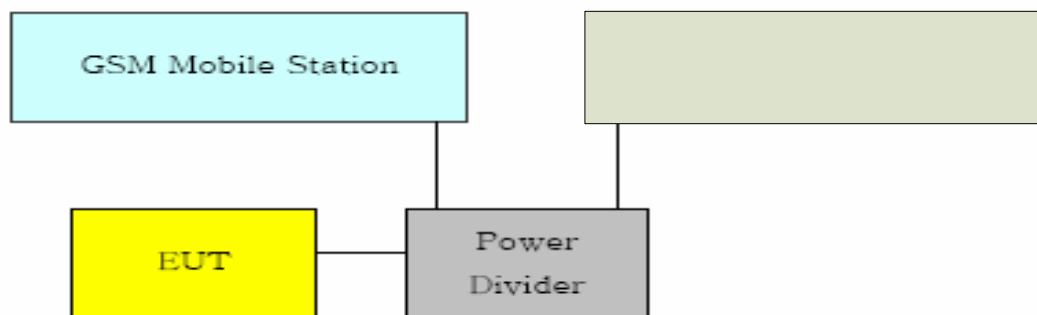

Test Method

- 1) The EUT was coupled to the EMI test receiver analyzer mode and the base station simulator through a power divider. The radio frequency load attached to the EUT antenna terminal was 50 Ohm. The lost of the cables the test system is calibrated to correct the readings.
- 2) The spectrum analyzer was set to Maxpeak Detector function and Maximum hold mode.
- 3) The resolution bandwidth of the spectrum analyzer was comparable to the emission bandwidth.

Note: --

Test Results for GPRS mode:

ARFCN	Peak output power 1 slot [dBm]
128	31.98
190	31.29
251	31.79
512	29.05
661	29.40
810	29.57

Test Results for EGPRS mode:

ARFCN	Peak output power 1 slot [dBm]
128	31.97
190	31.29
251	31.79
512	29.41
661	29.81
810	29.98

Test Results for WCDMA mode:

ARFCN	Peak output power [dBm]	RMS power [dBm]
4132	24.53	22.98
4175	24.65	22.77
4233	24.21	22.54
9262	23.48	22.30
9400	22.63	22.08
9538	22.09	21.72

Release 6 HSDPA mode:

The following 4 Sub-Test were completed according to the test requirements outlined in section 5.2A of the 3Gpp TS34.121 V8.4.0 specification. All TX RMS power requirements for power Class 3 were met according to table 5.2AA.5 and 5.2b.5. All UE channels and power ratio are set according to table C10.1.4&11.1.3 in the 3Gpp34.121 V8.4.0. RMC12.2kps is used for this testing.

HSDPA SUB-TEST Setting:

Sub-test	β_c	β_d	β_d (SF)	β_c/β_d	β_{hs}	CM(dB)	MPR(dB)
1	2/15	15/15	64	2/15	4/15	0.0	0.0
2	12/15	15/15	64	12/15	24/15	1.0	0.0
3	15/15	8/15	64	15/8	30/15	1.5	0.5
4	15/15	4/15	64	15/4	30/15	1.5	0.5

Note: the recommended HSDPA MPRs are implemented as per following sub-test.

Result:

Sub-test	RMS power [dBm]					
	Band V channel			Band II channel		
	4132	4175	4233	9262	9400	9538
1	21.72	21.55	21.46	21.29	22.00	22.12
2	21.39	21.17	21.02	21.35	21.73	21.85
3	20.62	20.69	20.62	20.61	21.03	20.83
4	20.61	20.6	20.41	20.45	20.99	20.82

Release 6 HSUPA mode:

The following 5 Sub-Test were completed according to the test requirements outlined in section 5.2A of the 3Gpp TS34.121 V8.4.0 specification. All TX RMS power requirements for power Class 3 were met according to table 5.2AA.5 and 5.2B.5. All UE channels and power ratio are set according to table C11.1.3 in the 3Gpp34.121 V8.4.0. RMC12.2kps is used for this testing.

HSUPA SUB-TEST Setting:

Sub-test	β_c	β_d	β_d (SF)	β_c/β_d	β_{hs}	β_{ec}
1	11/15	15/15	64	11/15	22/15	209/225
2	6/15	15/15	64	6/15	12/15	12/15
3	15/15	9/15	64	15/9	30/15	30/15
4	2/15	15/15	64	2/15	4/15	2/15
5	15/15	15/15	64	15/15	30/15	24/15

Sub-test	β_{ed} (SF)	β_{ed} (Codes)	CM (dB)	MPR (dB)	AG Index	E-TFCI
1	4	1	1.0	0.0	20	75
2	4	1	3.0	2.0	12	67
3	4	2	2.0	1.0	15	92
4	4	1	3.0	2.0	17	71
5	4	1	1.0	0.0	21	81

Note: the recommended HSUPA MPRs are implemented as per following sub-test.

Result:

Sub-test	RMS power [dBm]					
	Band V channel			Band II channel		
	4132	4175	4233	9262	9400	9538
1	21.05	20.65	20.85	21.67	21.03	20.6
2	19.71	19.9	19.76	19.92	19.5	19.48
3	20.38	20.2	20.22	20.36	20.13	20.15
4	19.83	19.45	19.39	19.99	19.95	20.03
5	21.05	21.08	21.41	19.58	20.5	20.32

4.7 Conducted Spurious Emission

Specifications:	2.1051,22.917,24.238					
Date of Tests	2009-9-11/14					
Test conditions:	Ambient Temperature: 15°C-35°C Relative Humidity: 30%-60% Air pressure: 86-106kPa					
Operation Mode	TX on, channel 190 and 661 for GPRS and EGPRS, and 4175 and 9400 for WCDMA					
Test Results:	Pass					
Test equipment Used:						
Asset Number	Description	Manufacturer	Model Number	Serial Number	Cal Due	State
7805	EMI Test Receiver	R/S	ESI26	100211	2010-01-11	Normal
023	Wireless Communications Test Set	Agilent	8960(E5515C)	GB41450323	2010-06-09	Normal
---	Power splitter	Jie sai	---	1000132	2010-01-04	Normal
111835	Wireless Communications Test Set	R&S	CMU200	1100000802	--	Normal

Limit Level Construction:

According to Part 24.238 (a), i.e., Out of band emissions. The power of any emission outside of the authorized operating frequency ranges must be attenuated below the transmitting power (P) by a factor of at least 43 + 10 log(P) dB, so the limit level is:
 $P(\text{dBm}) - (43 + 10 \log(P)) \text{ dB} = -13\text{dBm}$

Limits for Radiated spurious emissions(UE)

Frequency range	Limit Level /Resolution Bandwidth
30 MHz to 20000 MHz	-13dBm/1MHz

Test Setup:

During the process of testing, the EUT was controlled via Wireless Communications Test Set to ensure max power transmission and proper modulation and measured by Rhode & Schwarz EMI test receiver (ES126)

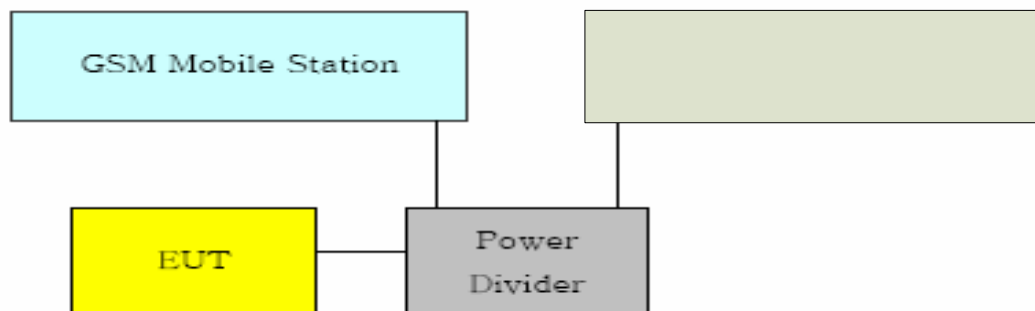

Test Method

The measurement was performed accordance with section 2.2.13 of ANSI/TIA-603-B-2002: *Land Mobile FM or PM Communications Equipment Measurement and Performance Standards*.

The following steps outline the procedure used to measure the conducted emissions from the EUT.

1. Determine frequency range for measurements: From CFR 2.1057 the spectrum should be investigated from the lowest radio frequency generated in the equipment up to at least the 10th harmonic of the carrier frequency. For the equipment under test, this equates to a frequency range of 30 MHz to 19.1 GHz, data taken from 30 MHz to 20 GHz.
2. Determine EUT transmit frequencies: below outlines the band edge frequencies pertinent to conducted emissions testing.

Note: --

Test Results for GPRS mode:

Out of band emission	
Frequency [MHz]	Level (dBm)
--	--

Graphical results for GPRS mode:

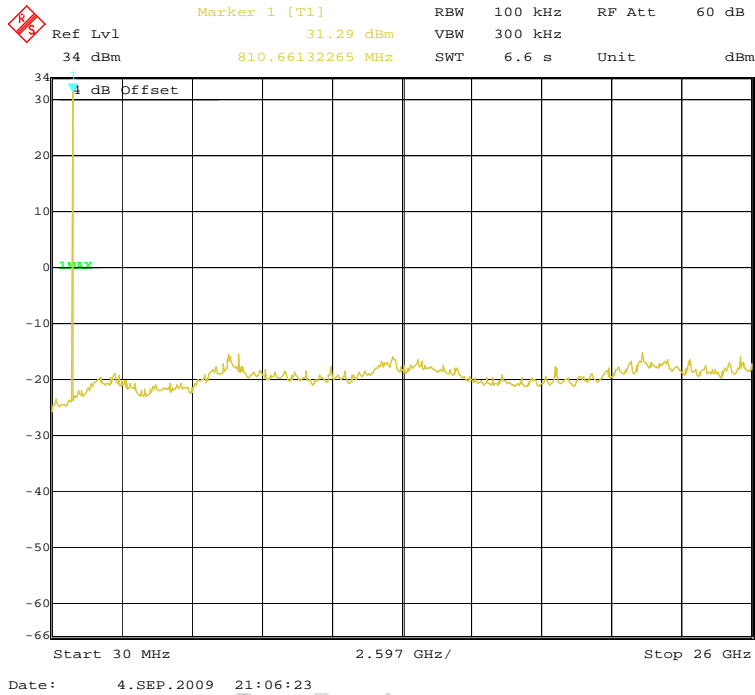

Channel 190

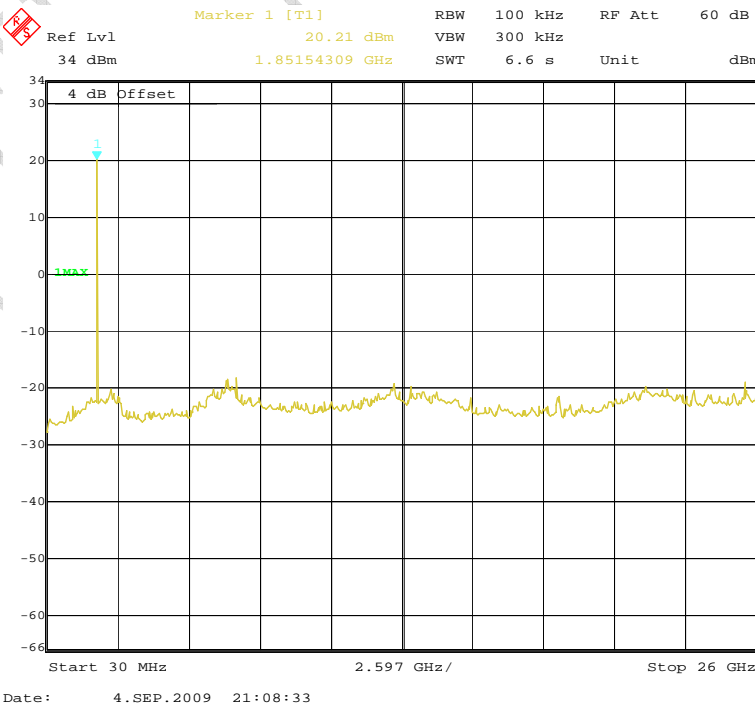

Channel 661

Test Results for EGPRS mode:

Out of band emission	
Frequency [MHz]	Level (dBm)
--	--

Graphical results for EGPRS mode:

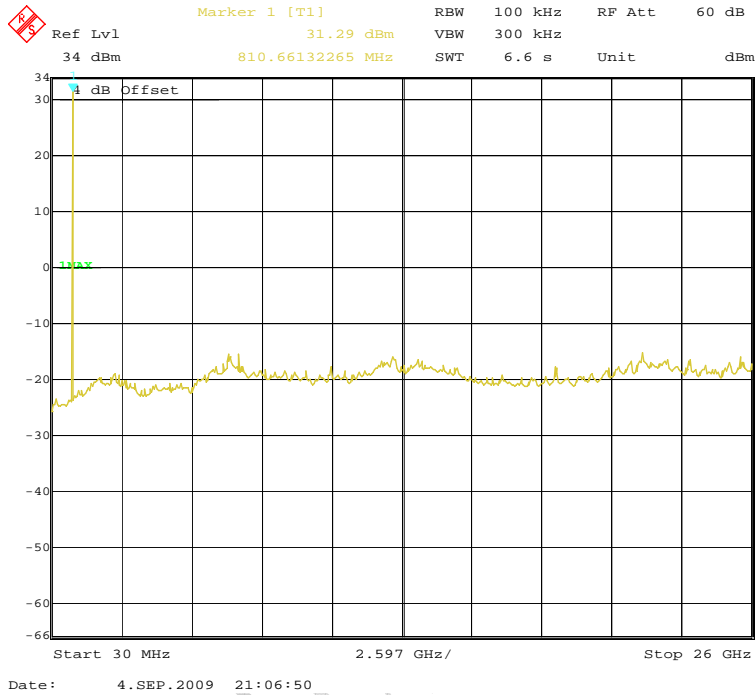

Channel 190

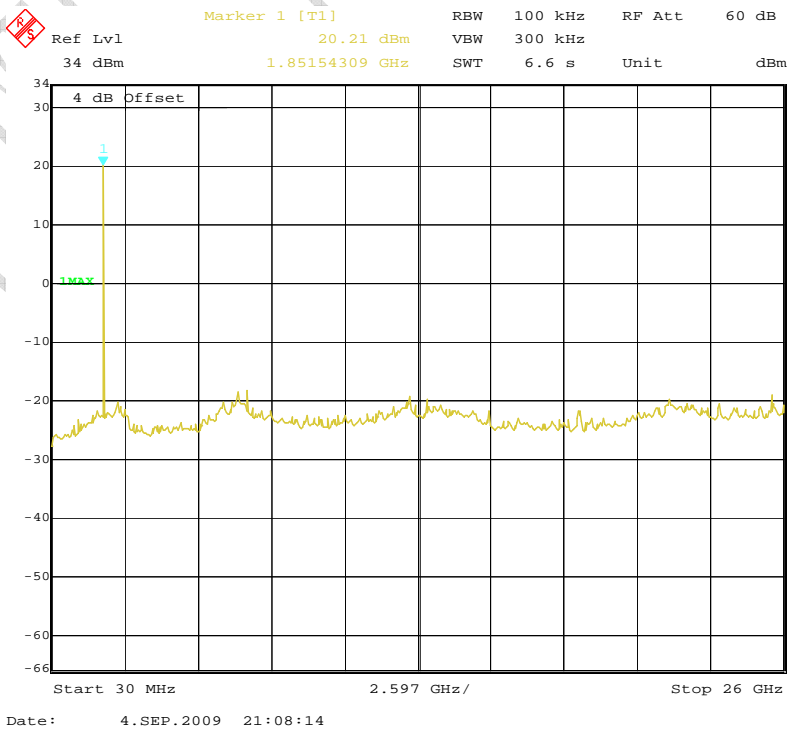

Channel 661

Test Results for WCDMA mode:

Out of band emission	
Frequency [MHz]	Level (dBm)
--	--

Graphical results for WCDMA mode:

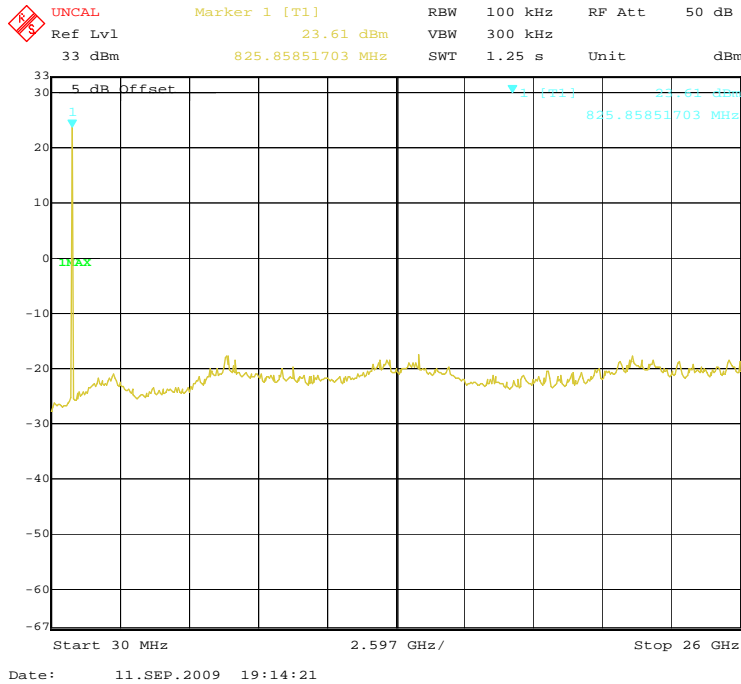

Channel 4175

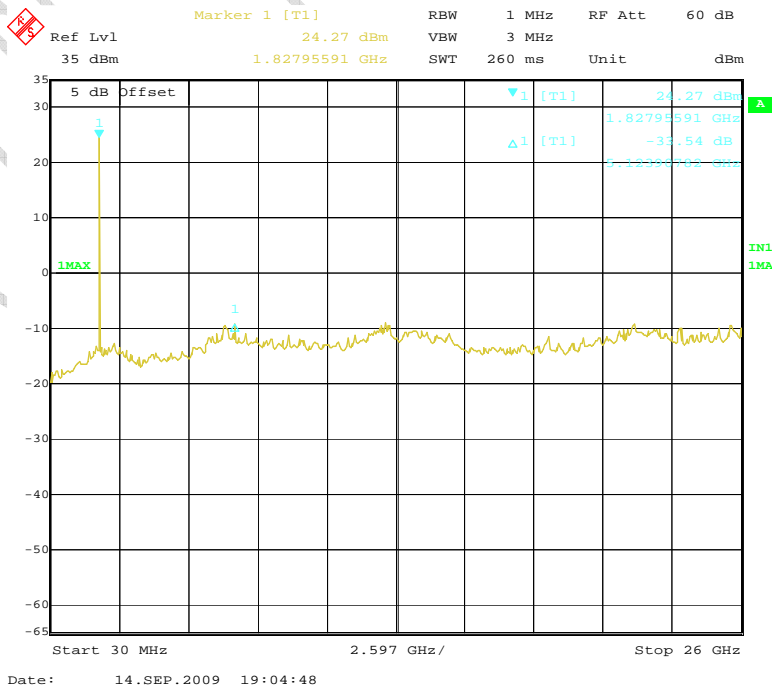

Channel 9400

4.8 Band Edge

Specifications:	2.1051, 24.238, 2.1053, 22.917					
Date of Tests	2009-9-11/15					
Test conditions:	Ambient Temperature: 15°C-35°C Relative Humidity: 30%-60% Air pressure: 86-106kPa					
Operation Mode	TX on, channel 128, 251, 512 and 810 for GSM and 4132, 4233, 9262 and 9538 for WCDMA					
Test Results:	Pass					
Test equipment Used:						
Asset Number	Description	Manufacturer	Model Number	Serial Number	Cal Due	State
7805	EMI Test Receiver	R/S	ESI26	100211	2010-01-11	Normal
023	Wireless Communications Test Set	Agilent	8960(E5515C)	GB41450323	2010-06-09	Normal
---	Power splitter	Jie sai	---	1000132	2010-01-04	Normal
111835	Wireless Communications Test Set	R&S	CMU200	1100000802	--	Normal

Limit Level Construction:

According to Part 24.238 (a), i.e., Out of band emissions. The power of any emission outside of the authorized operating frequency ranges must be attenuated below the transmitting power (P) by a factor of at least $43 + 10 \log(P)$ dB, so the limit level is:
 $P(\text{dBm}) - (43 + 10 \log(P)) \text{ dB} = -13\text{dBm}$

Limits for Radiated spurious emissions(UE)

Frequency range	Limit Level /Resolution Bandwidth
30 MHz to 20000 MHz	-13dBm/1MHz

Test Setup:

During the process of testing, the EUT was controlled via the Wireless Communications Test Set to ensure max power transmission and proper modulation and measured by Rhode & Schwarz EMI test receiver (ESI26).

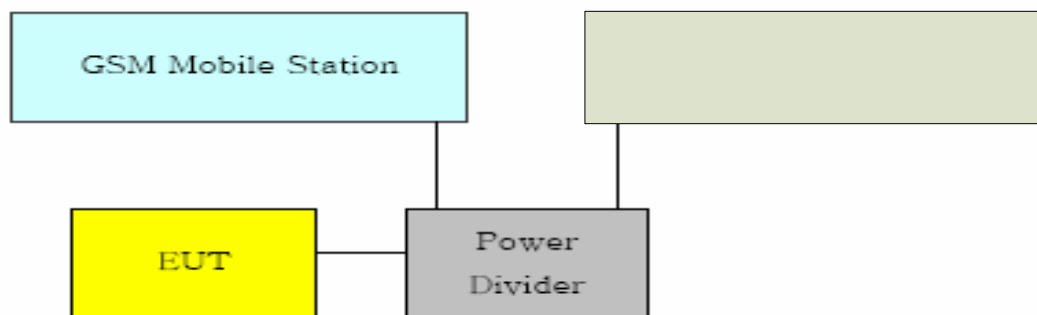

Test Method

- 1) The EUT was coupled to the EMI test receiver analyzer mode and the base station simulator through a power divider. The radio frequency load attached to the EUT antenna terminal was 50 Ohm. The loss of the cables the test system is calibrated to correct the readings.
- 2) The spectrum analyzer was set to Maxpeak Detector function and Maximum hold mode.
- 3) The resolution bandwidth of the spectrum analyzer was comparable to the emission bandwidth.

Note: --

Test Results:

GPRS mode:

Band-edge emission		
EUT Channel	Frequency [MHz]	Level [dBm]
128 Left band edge	823.99759519	-15.26
251 Right band edge	849.00240481	-17.11
512 Left band edge	1849.99760	-18.31
810 Right band edge	1910.00240	-18.97

EGPRS mode:

Band-edge emission		
EUT Channel	Frequency [MHz]	Level [dBm]
128 Left band edge	823.99358717	-15.57
251 Right band edge	849.00240481	-16.39
512 Left band edge	1849.99760	-17.90
810 Right band edge	1910.01844	-19.40

WCDMA mode:

Band-edge emission		
EUT Channel	Frequency [MHz]	Level [dBm]
4132 Left band edge	824.04979960	-20.64
4233 Right band edge	848.99478958	-17.76
9262 Left band edge	1850.20521	-14.95
9538 Right band edge	1910.03487	-14.23

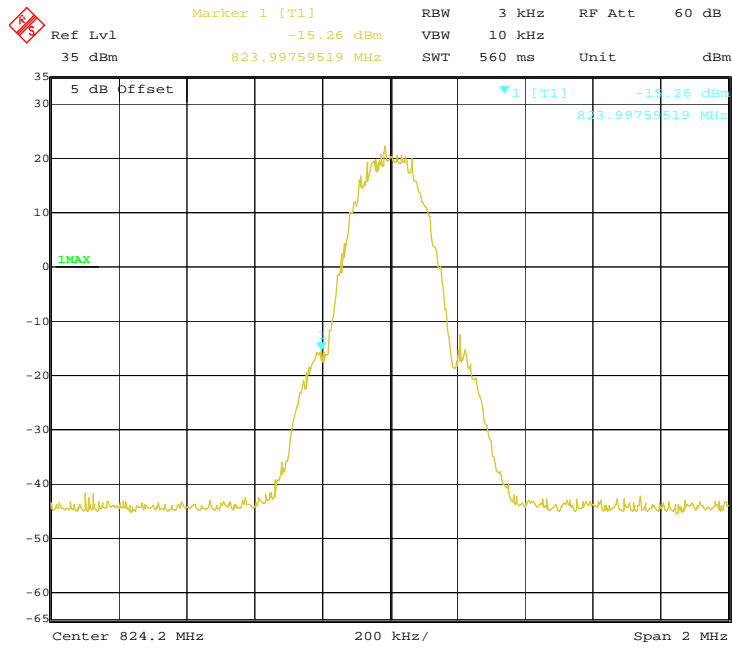

Date: 11.SEP.2009 12:03:50

GPRS channel 128 Left band edge

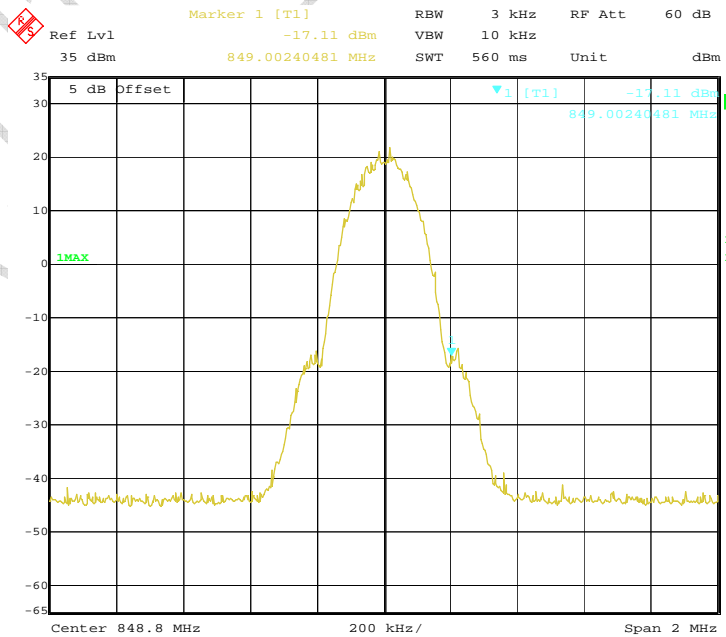

Date: 11.SEP.2009 12:10:41

GPRS channel 251 Right band edge

FCC Parts 2, 22, 24
Equipment: MC8795V

REPORT NO.: I09GW6944-FCC-EMC-3

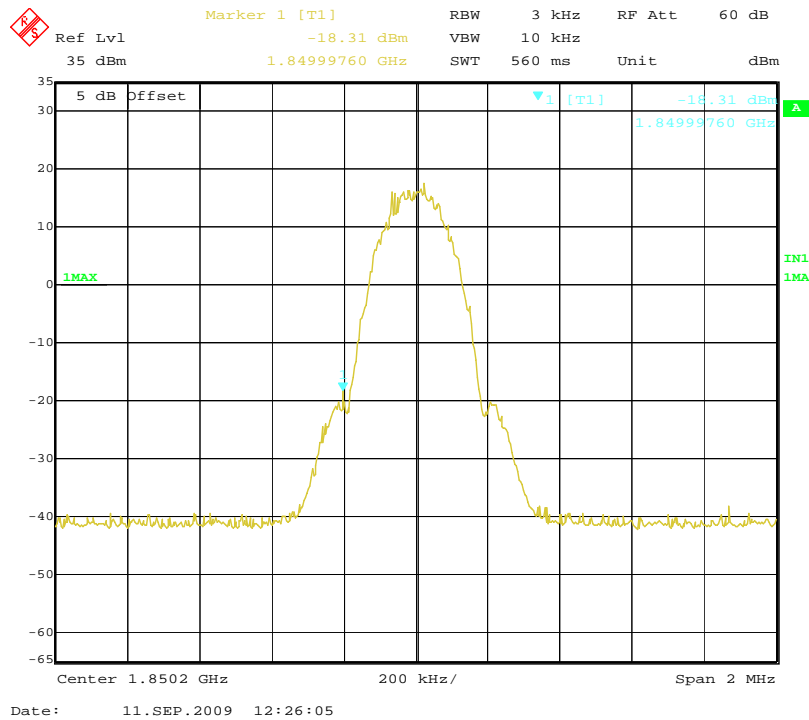

GPRS channel 512 Left band edge

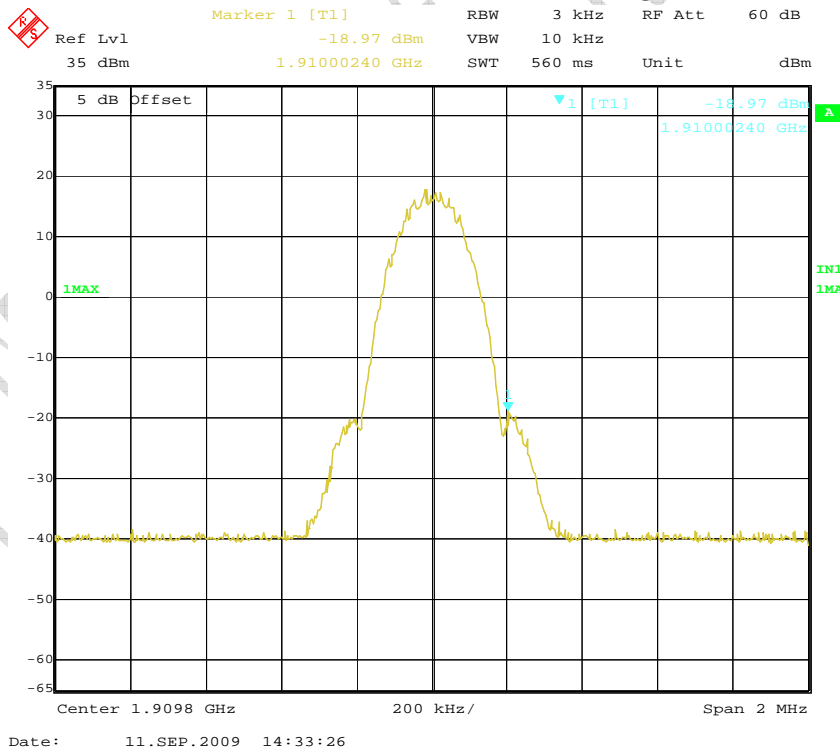

GPRS channel 810 Right band edge

FCC Parts 2, 22, 24
Equipment: MC8795V

REPORT NO.: I09GW6944-FCC-EMC-3

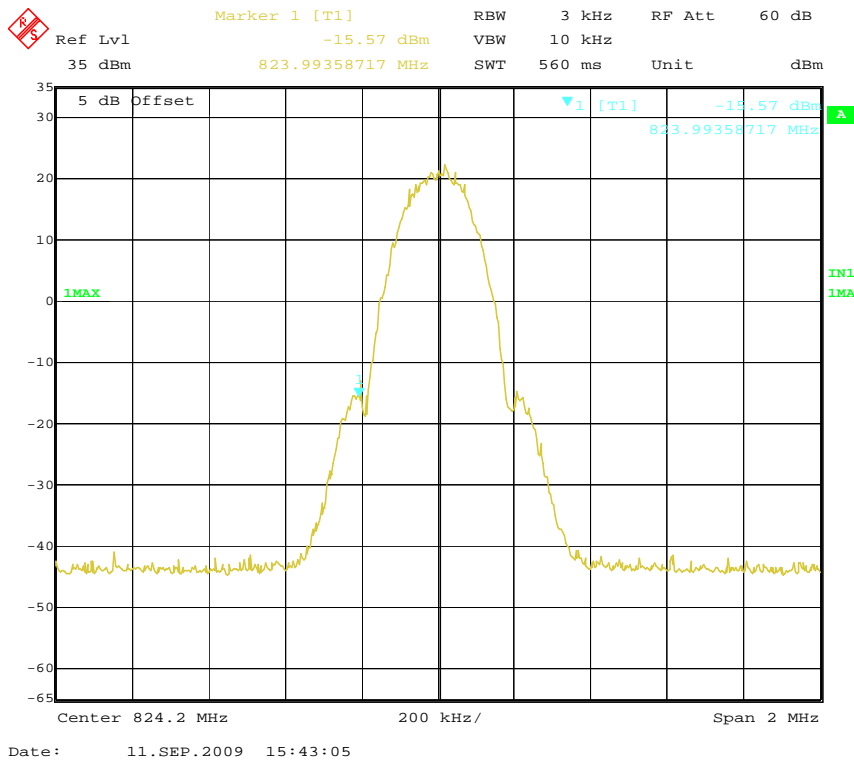

EGPRS channel 128 Left band edge

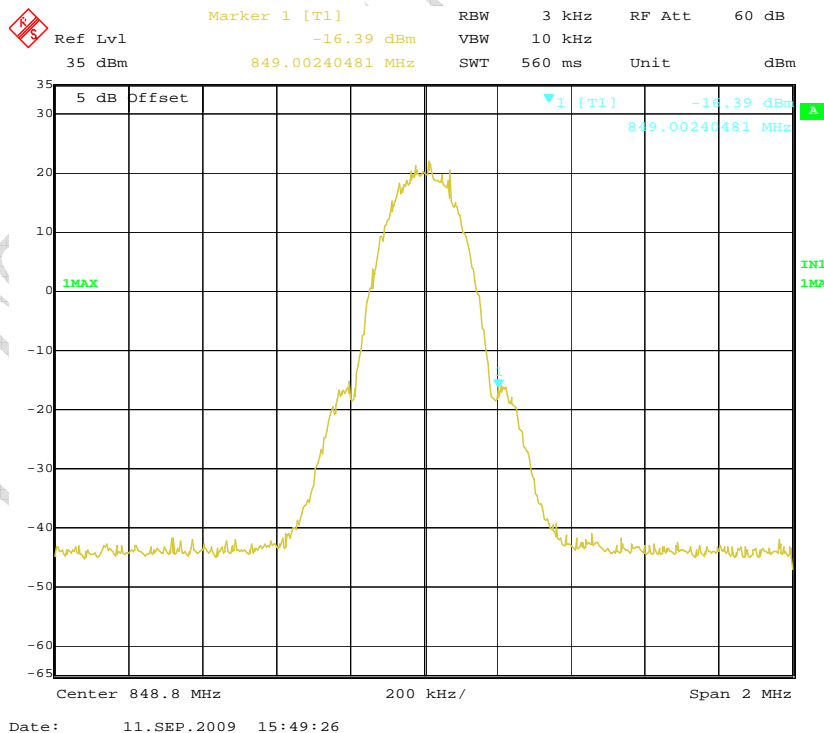

EGPRS channel 251 Right band edge

FCC Parts 2, 22, 24
Equipment: MC8795V

REPORT NO.: I09GW6944-FCC-EMC-3

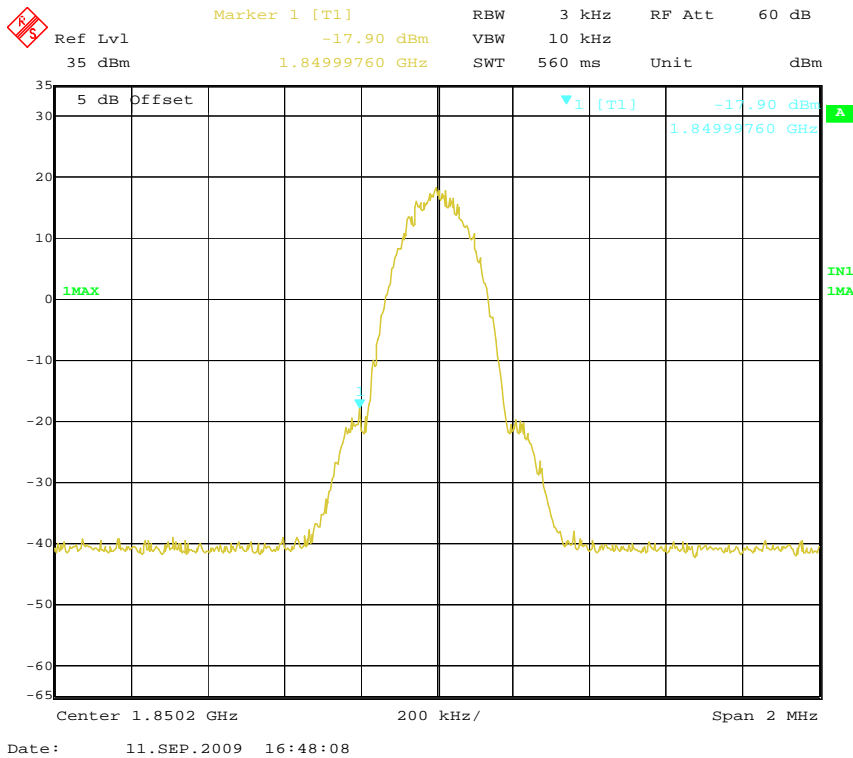

EGPRS channel 512 Left band edge

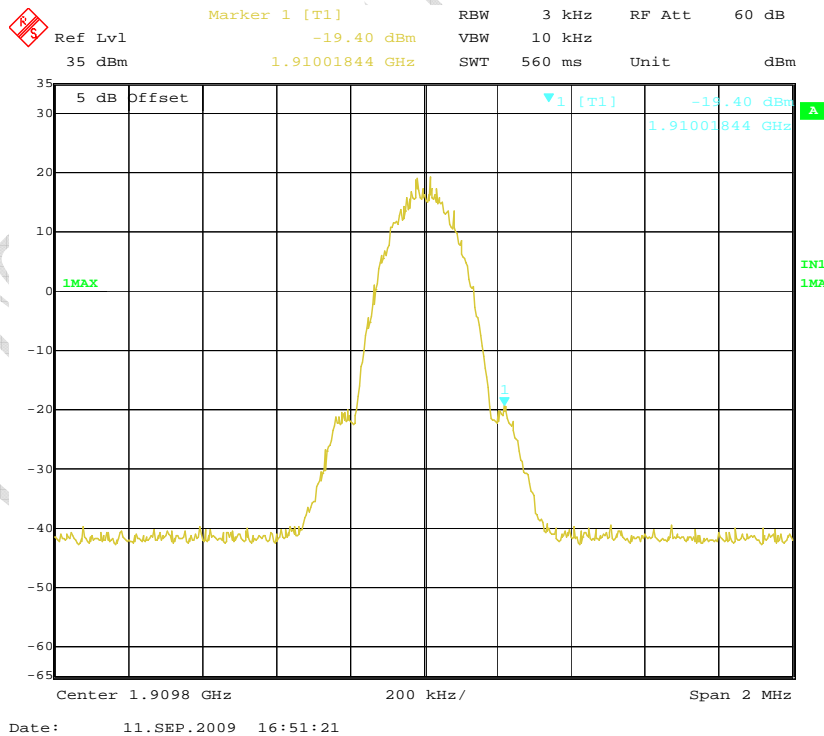

EGPRS channel 810 Right band edge

FCC Parts 2, 22, 24
Equipment: MC8795V

REPORT NO.: I09GW6944-FCC-EMC-3

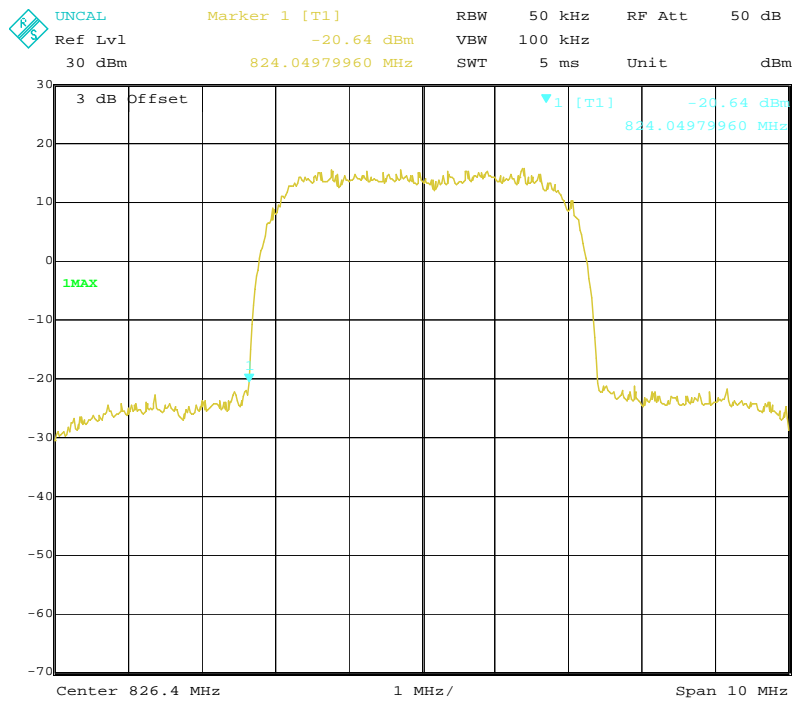

Date: 27.SEP.2009 17:45:44

WCDMA channel 4132 left band edge

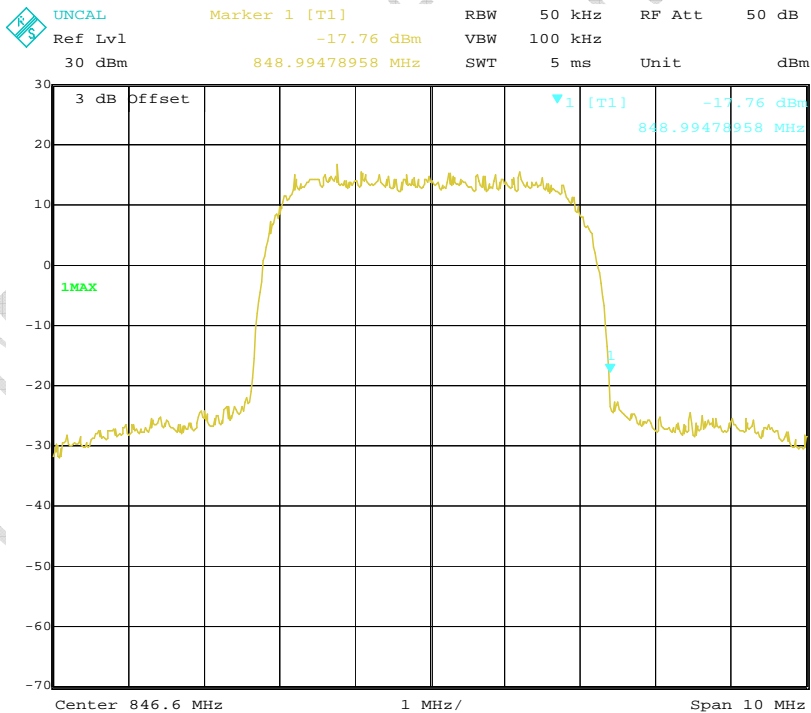

Date: 27.SEP.2009 17:46:46

WCDMA channel 4233 right band edge

FCC Parts 2, 22, 24
Equipment: MC8795V

REPORT NO.: I09GW6944-FCC-EMC-3

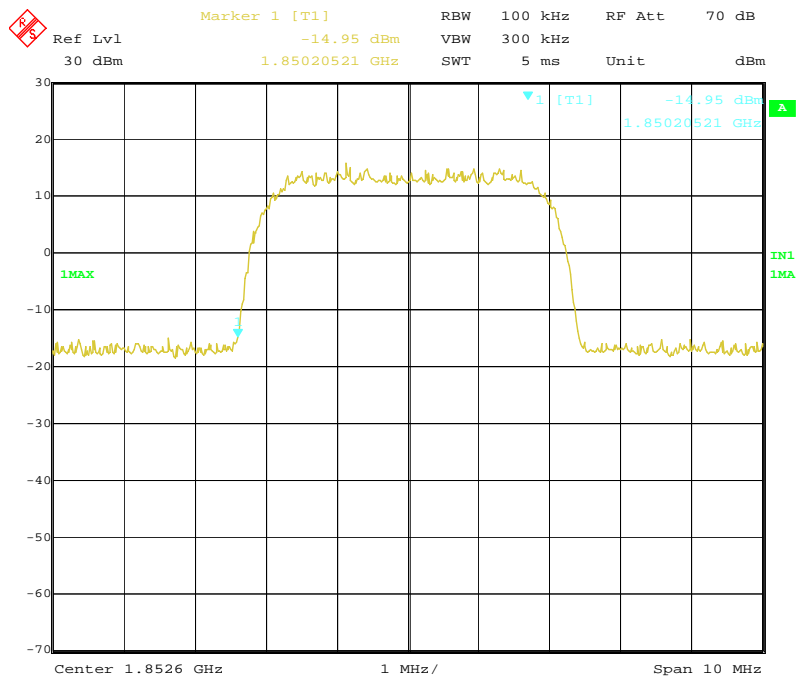

Date: 15.SEP.2009 12:30:16

WCDMA channel 9262 left band edge

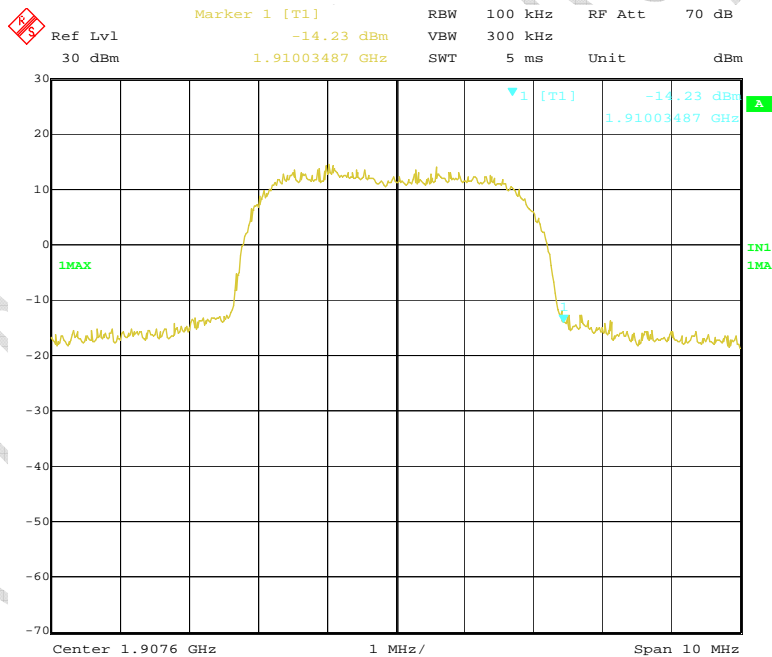

Date: 15.SEP.2009 12:31:17

WCDMA channel 9538 right band edge

Annex A External Photos

The EUT is a PCI card. There is no enclosure. So there is no external photo.

TTL Test Report

ANNEX C Deviations from Prescribed Test Methods

No deviation from Prescribed Test Methods.

————— The End of this Report —————

CITL Test Report