





PRE-RELEASE

APPROVED SOURCE(S) OF SUPPLY	PART NUMBER
1. LAIRD	CAF96332AA
2.	
3.	
4.	
5.	
6.	

REVISION	REV STATUS OF SHEETS
5	SHEET
4	
3	
2	
1	

REVISIONS					
DWG REV	ECN	ZONE	DESCRIPTION	DATE	DRAWN & APPROVED
1			INITIAL DRAWING CREATION		
2			ADDED PADS; SHORTEN ADHES.	8-1-08	DWG
A	320687	-	RELEASED, FORMERLY REV 2	8-27-08	RZ

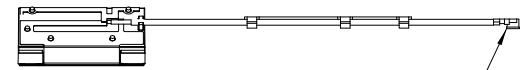

CONNECTOR ORIENTED IN THIS DIRECTION

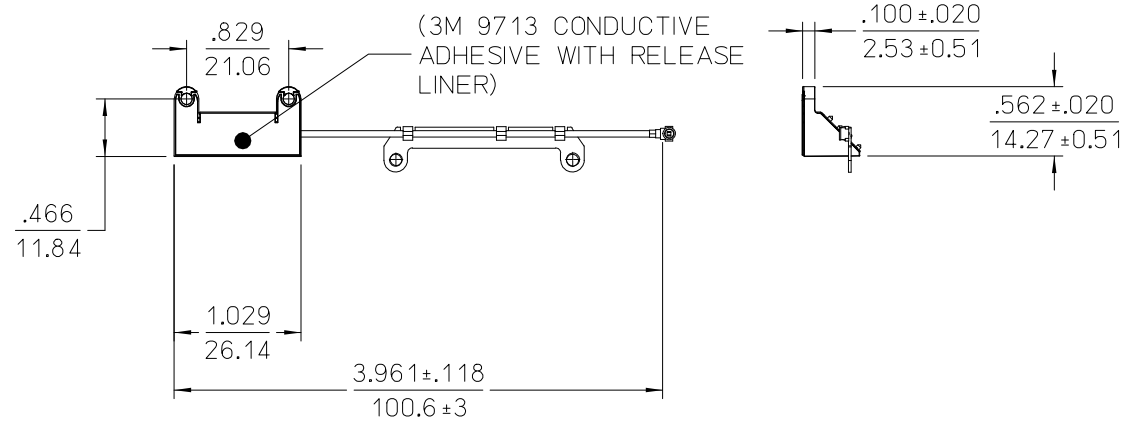

NOTES: UNLESS OTHERWISE SPECIFIED

- COUNTRY OF ORIGIN REQUIREMENTS SHALL CONFORM TO SPECIFICATION 609030.
- THIS PART OR ASSEMBLY MUST CONFORM TO DOCUMENT 631869 INTERMEC RESTRICTED SUBSTANCES COMPLIANCE REQUIREMENTS, MOST CURRENT REVISION.
- PART REVISION CONTROLLED BY REVISION HISTORY DOCUMENT.
- REFER TO MANUFACTURERS COMPLETE DESIGN PARAMETERS FOR ADDITIONAL INFORMATION.
- DIMENSIONS: INCH  
MM
- FREQUENCY RANGE: 2.4-2.497 GHZ (BG)  
4.9-5.825 GHZ (A)
- CHANGES REQUIRE SAC APPROVAL.

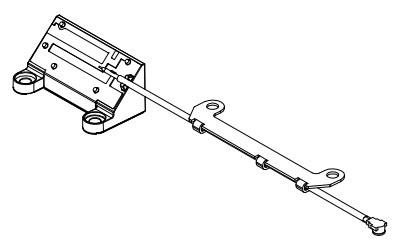

-001

SOURCE CONTROL CONTROL

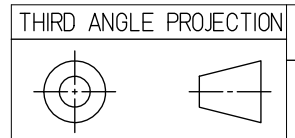

CAD DB.REF- WM  
SYSTEM - HP-ME10  
UNLESS OTHERWISE SPECIFIED, DIMENSIONS ARE IN INCHES.

NOTICE  
THIS DRAWING SHALL NOT BE DUPLICATED OR USED FOR ANY PURPOSE OTHER THAN THAT FOR WHICH PROVIDED. THE INFORMATION DISCLOSED HEREIN ORIGINATED BY AND IS THE PROPERTY OF INTERMEC TECHNOLOGIES CORPORATION AND EXCEPT FOR RIGHTS EXPRESSLY GRANTED BY WRITTEN CONSENT, SUCH INFORMATION SHALL NOT BE DISCLOSED OR DISSEMINATED WHOLE OR IN PART. INTERMEC TECHNOLOGIES CORPORATION RESERVES ALL PATENT, PROPRIETARY, DESIGN, USE, SALE, MANUFACTURING AND REPRODUCTION RIGHTS THERETO.

.X ± .1  
.XX ± .02  
.XXX ± .010  
ANGLES ± 1°

APPROVALS		DATE
DRAWN	G.RAVEN	4-3-08
CHECKED	R.ZIGLER	8-27-08
RESP ENG	D.GILPIN	8-27-08

SEE ECN FOR MFG, QA AND SAC APPROVALS

**Intermec Technologies Corporation** 6001 36TH AVENUE WEST EVERETT, WA 98203

TITLE: ANTENNA, DIVERSITY, CK3

SIZE	CAGE CODE	DRAWING NUMBER
C	33825	805-828
SCALE	NONE	USED ON CK3
		SHEET 1 OF 1

PRE-RELEASE