

FCC 47 CFR PART 15 SUBPART E

TEST REPORT

For

Data Collection PC

Model: CV61, 1011CM01

Trade Name: INTERMEC

Issued to

**Intermec Technologies Corporation
9680 Old Bailes Road, Fort Mill, South Carolina, United States 29707**

Issued by

**Compliance Certification Services Inc.
No.11, Wugong 6th Rd., Wugu Dist.,
New Taipei City 24891, Taiwan. (R.O.C.)
<http://www.ccsrf.com>
service@ccsrf.com
Issued Date: June 16, 2016**



Note: This report shall not be reproduced except in full, without the written approval of Compliance Certification Services Inc. This document may be altered or revised by Compliance Certification Services Inc. personnel only, and shall be noted in the revision section of the document.

Revision History

Rev.	Issue Date	Revisions	Effect Page	Revised By
00	June 16, 2016	Initial Issue	ALL	Doris Chu

TABLE OF CONTENTS

1. TEST RESULT CERTIFICATION	4
2. EUT DESCRIPTION.....	5
3. TEST METHODOLOGY.....	6
3.1 EUT CONFIGURATION	6
3.2 EUT EXERCISE	6
3.3 GENERAL TEST PROCEDURES	6
3.4 FCC PART 15.205 RESTRICTED BANDS OF OPERATIONS.....	7
3.5 DESCRIPTION OF TEST MODES	8
4. INSTRUMENT CALIBRATION	9
4.1 MEASURING INSTRUMENT CALIBRATION.....	9
4.2 MEASUREMENT EQUIPMENT USED.....	9
4.3 MEASUREMENT UNCERTAINTY	10
5 FACILITIES AND ACCREDITATIONS	11
5.1 FACILITIES	11
5.2 LABORATORY ACCREDITATIONS AND LISTING	11
5.3 TABLE OF ACCREDITATIONS AND LISTINGS	12
6 SETUP OF EQUIPMENT UNDER TEST	13
6.1 SETUP CONFIGURATION OF EUT	13
6.2 SUPPORT EQUIPMENT	13
7 FCC PART 15 REQUIREMENTS	14
7.1 6DB BANDWIDTH	14
7.2 MAXIMUM CONDUCTED OUTPUT POWER	24
7.3 BAND EDGES MEASUREMENT	26
7.4 PEAK POWER SPECTRAL DENSITY	44
7.5 RADIATED EMISSIONS.....	54
7.6 POWERLINE CONDUCTED EMISSIONS	76
APPENDIX I PHOTOGRAPHS OF TEST SETUP.....	79

1. TEST RESULT CERTIFICATION

Applicant: Intermec Technologies Corporation
9680 Old Bailes Road, Fort Mill, South Carolina, United States 29707

Manufacturer: Intermec Technologies Corporation
9680 Old Bailes Road, Fort Mill, South Carolina, United States 29707

Equipment Under Test: Data Collection PC

Model Number: CV61, 1011CM01

Trade Name: INTERMEC

Date of Test: December 16, 2011 and June 16, 2016.

APPLICABLE STANDARDS	
STANDARD	TEST RESULT
FCC 47 CFR Part 15 Subpart E	No non-compliance noted

We hereby certify that:

Compliance Certification Services Inc. tested the above equipment in accordance with the requirements set forth in the above standards. The test results show that the equipment tested is capable of demonstrating compliance with the requirements as documented in this report.

The test results of this report relate only to the tested sample identified in this report.

Approved by

Tested by

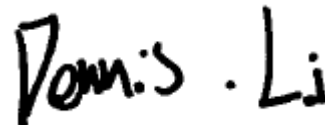
Miller Lee
Manager
Compliance Certification Services Inc.

Dennis Li
Engineer
Compliance Certification Services Inc.

2. EUT DESCRIPTION

Product	Data Collection PC
Model Number	CV61, 1011CM01
Model Discrepancy	All the specification and layout are identical except they come with different model numbers for marketing purposes.
Trade Name	INTERMEC
Power Supply	Power from Power Adapter Intermec Technologies Corporation / 9006AE01 I/P: 100-240V, 50-60Hz, 1500mA O/P: 12V, 8300mA, 100W
Received Date	May 4, 2016
Frequency Range	IEEE 802.11a/ IEEE 802.11n HT 20 MHz: 5745~5825 MHz IEEE 802.11n HT 40 MHz: 5755~5795 MHz
Transmit Power	IEEE 802.11a mode: 13.57 dBm IEEE 802.11n HT 20 MHz mode: 16.22 dBm IEEE 802.11n HT 40 MHz mode: 15.58 dBm
Number of Channels	IEEE 802.11a mode: 5 Channels IEEE 802.11n HT 20 MHz mode: 5 Channels IEEE 802.11n HT 40 MHz mode: 2 Channels
Antenna Specification	1. External antenna 1 Laird Technologies / Model Number: CAF94606AA Main: Patch Antenna / Gain: 3.0 dBi 2. External antenna 2 Laird Technologies / Model Number: OEM2689-P110 Main: Omni Antenna / 2.4G Gain: 3.0 dBi, 5G Gain: 5.0 dBi 3. Internal MIMO antenna Venture Corp. Ltd / MIMO1 antenna: Part No.: VE027-6007-A0 MIMO2 antenna: Part No.: VE027-6008-A0 Main: PIFA Antenna / 2.4G Gain: 3.0 dBi, 5G Gain:5.25 dBi Aux: PIFA Antenna / 2.4G Gain:4.92 dBi, 5G Gain:5.36 dBi 2.4G MIMO: $10 \cdot \text{LOG}(((10^{(4.38/20)}+10^{(4.92/20)})^2)/2)=7.66$ dBi 5G MIMO: $10 \cdot \text{LOG}(((10^{(5.25/20)}+10^{(5.36/20)})^2)/2)=8.32$ dBi

3. TEST METHODOLOGY

The tests documented in this report were performed in accordance with ANSI C63.10: 2013 and FCC CFR 47 Part 15.207, 15.209, 15.407 and KDB 789033 D02 General UNII Test Procedures New Rules v01r02.

3.1 EUT CONFIGURATION

The EUT configuration for testing is installed for RF field strength measurement to meet the Commissions requirement, and is operated in a manner intended to generate the maximum emission in a continuous normal application.

3.2 EUT EXERCISE

The EUT is operated in the engineering mode to fix the Tx frequency for the purposes of measurement.

According to its specifications, the EUT must comply with the requirements of Section 15.407 under the FCC Rules Part 15 Subpart E.

3.3 GENERAL TEST PROCEDURES

Conducted Emissions

According to the requirements in ANSI C63.10: 2013, the conducted emission from the EUT is measured in the frequency range between 0.15 MHz and 30MHz, using the CISPR Quasi-Peak detector mode.

Radiated Emissions

The EUT is placed on the turntable, which is 1.5 m above the ground plane. The turntable is then rotated for 360 degrees to determine the proper orientation for the maximum emission level. The EUT is set 3m away from the receiving antenna, which is varied from 1m to 4m to find out the highest emission level. And, each emission is to be maximized by changing the horizontal and vertical polarization of the receiving antenna. In order to find out the maximum emissions, exploratory radiated emission measurements were made according to the requirements in ANSI C63.10: 2013.

3.4 FCC PART 15.205 RESTRICTED BANDS OF OPERATIONS

(a) Except as shown in paragraph (d) of this section, only spurious emissions are permitted in any of the frequency bands listed below:

MHz	MHz	MHz	GHz
0.090 - 0.110	16.42 - 16.423	399.9 - 410	4.5 - 5.15
¹ 0.495 - 0.505	16.69475 - 16.69525	608 - 614	5.35 - 5.46
2.1735 - 2.1905	16.80425 - 16.80475	960 - 1240	7.25 - 7.75
4.125 - 4.128	25.5 - 25.67	1300 - 1427	8.025 - 8.5
4.17725 - 4.17775	37.5 - 38.25	1435 - 1626.5	9.0 - 9.2
4.20725 - 4.20775	73 - 74.6	1645.5 - 1646.5	9.3 - 9.5
6.215 - 6.218	74.8 - 75.2	1660 - 1710	10.6 - 12.7
6.26775 - 6.26825	108 - 121.94	1718.8 - 1722.2	13.25 - 13.4
6.31175 - 6.31225	123 - 138	2200 - 2300	14.47 - 14.5
8.291 - 8.294	149.9 - 150.05	2310 - 2390	15.35 - 16.2
8.362 - 8.366	156.52475 -	2483.5 - 2500	17.7 - 21.4
8.37625 - 8.38675	156.52525	2655 - 2900	22.01 - 23.12
8.41425 - 8.41475	156.7 - 156.9	3260 - 3267	23.6 - 24.0
12.29 - 12.293	162.0125 - 167.17	3332 - 3339	31.2 - 31.8
12.51975 - 12.52025	167.72 - 173.2	3345.8 - 3358	36.43 - 36.5
12.57675 - 12.57725	240 - 285	3600 - 4400	(²)
13.36 - 13.41	322 - 335.4		

¹ Until February 1, 1999, this restricted band shall be 0.490-0.510 MHz.

² Above 38.6

(b) Except as provided in paragraphs (d) and (e), the field strength of emissions appearing within these frequency bands shall not exceed the limits shown in Section 15.209. At frequencies equal to or less than 1000 MHz, compliance with the limits in Section 15.209 shall be demonstrated using measurement instrumentation employing a CISPR quasi-peak detector. Above 1000 MHz, compliance with the emission limits in Section 15.209 shall be demonstrated based on the average value of the measured emissions. The provisions in Section 15.35 apply to these measurements.

3.5 DESCRIPTION OF TEST MODES

The EUT (model: CV61) had been tested under operating condition.

The EUT is a 2x2 configuration spatial MIMO (2Tx & 2Rx) without beam forming function that operate in double TX chains and double RX chains. The 2x2 configuration is implemented with two outside TX & RX chains (Chain 0 and 1).

Software used to control the EUT for staying in continuous transmitting and receiving mode was programmed.

After verification, all tests were carried out with the worst case test modes as shown below except radiated spurious emission below 1GHz, which worst case was in normal link mode only.

IEEE 802.11a mode / 5745 ~ 5825MHz

Channel Low (5745MHz), Channel Mid (5785MHz) and Channel High (5825MHz) with 6Mbps data rate were chosen for full testing.

IEEE 802.11n HT 20 MHz mode / 5745 ~ 5825MHz

Channel Low(5745MHz), Channel Mid(5785MHz) and Channel High(5825MHz) with 6.5Mbps data rate were chosen for full testing.

IEEE 802.11n HT 40 MHz mode / 5755 ~ 5795MHz

Channel Low(5755MHz) and Channel High(5795MHz) with 13.5Mbps data rate were chosen for full testing.

The field strength of spurious emission was measured in the following position: EUT stand-up position (Z axis), lie-down position (X, Y axis). The worst emission was found in stand-up position (Z axis) and the worst case was recorded.

4. INSTRUMENT CALIBRATION

4.1 MEASURING INSTRUMENT CALIBRATION

The measuring equipment, which was utilized in performing the tests documented herein, has been calibrated in accordance with the manufacturer's recommendations for utilizing calibration equipment, which is traceable to recognized national standards.

4.2 MEASUREMENT EQUIPMENT USED

Equipment Used for Emissions Measurement

Remark: Each piece of equipment is scheduled for calibration once a year and Loop Antenna is scheduled for calibration once three years.

Wugu 966 Chamber A					
Name of Equipment	Manufacturer	Model	Serial Number	Calibration Date	Calibration Due
Bilog Antenna	Sunol Sciences	JB3	A030105	08/06/2015	08/05/2016
EMI Test Receiver	R&S	ESCI	100064	05/31/2016	05/30/2017
Horn Antenna	EMCO	3117	55165	02/24/2016	02/23/2017
Horn Antenna	EMCO	3116	26370	01/15/2016	01/14/2017
K Type Cable	Huber+Suhner	SUCOFLEX 102	29406/2	01/12/2016	01/11/2017
K Type Cable	Huber+Suhner	SUCOFLEX 102	22470/2	01/12/2016	01/11/2017
Pre-Amplifier	MITEQ	AMF-6F-260400-40-8P	985646	01/14/2016	01/13/2017
Pre-Amplifier	EMCI	EMC 012635	980151	06/08/2016	06/07/2017
Pre-Amplifier	EMCI	EM330	N/A	06/08/2016	06/07/2017
Spectrum Analyzer	Agilent	E4446A	US42510252	12/08/2015	12/07/2016
Antenna Tower	CCS	CC-A-1F	N/A	N.C.R	N.C.R
Controller	CCS	CC-C-1F	N/A	N.C.R	N.C.R
Turn Table	CCS	CC-T-1F	N/A	N.C.R	N.C.R
Test S/W	EZ-EMC (CCS-3A1RE)				

Conducted Emissions Test Site					
Name of Equipment	Manufacturer	Model	Serial Number	Calibration Date	Calibration Due
DC Power Supplies	GW Instek	SPS-3610	GPE880163	01/19/2016	01/18/2017
Power Meter	Anritsu	ML2495A	1012009	07/08/2015	07/07/2016
Power Sensor	Anritsu	MA2411B	917072	07/08/2015	07/07/2016
Signal Analyzer	R&S	FSV 40	101073	07/20/2015	07/19/2016
Spectrum Analyzer	Agilent	E4446A	US42510268	02/15/2016	02/14/2017
Thermostatic/Hrgrosatic Chamber	TAICHY	MHG-150LF	930619	10/08/2015	10/07/2016
Vector Signal Generator	R&S	SMU 200A	102239	03/10/2016	03/09/2017
AC Power Source	EXTECH	6205	1140845	N.C.R	N.C.R

Conducted Emission room # A					
Name of Equipment	Manufacturer	Model	Serial Number	Calibration Date	Calibration Due
TEST RECEIVER	R&S	ESCI	101201	09/06/2011	09/05/2012
LISN (EUT)	SCHWARZBECK	NSLK 8127	8127527	12/14/2011	12/13/2012
LISN	SCHWARZBECK	NSLK 8127	8127526	12/14/2011	12/13/2012
BNC CABLE	EMCI	5Dr	BNC A6	12/08/2011	12/07/2012
THERMO-HYGRO METER	TECPEL	DTM-303	NO.3	11/22/2011	11/21/2012

4.3 MEASUREMENT UNCERTAINTY

PARAMETER	UNCERTAINTY
AC Powerline Conducted Emission	+/- 1.2575
Emission bandwidth, 6dB bandwidth	+/- 0.0014
RF output power, conducted	+/- 1.1372
Power density, conducted	+/- 1.9240
3M Semi Anechoic Chamber / 30M~200M	+/- 4.0138
3M Semi Anechoic Chamber / 200M~1000M	+/- 3.9483
3M Semi Anechoic Chamber / 1G~6G	+/- 2.5975
3M Semi Anechoic Chamber / 6G~18G	+/- 2.6112
3M Semi Anechoic Chamber / 18G~26G	+/- 2.7389
3M Semi Anechoic Chamber / 26G~40G	+/- 2.9683

Remark: This uncertainty represents an expanded uncertainty expressed at approximately the 95% confidence level using a coverage factor of $k=2$.

5 FACILITIES AND ACCREDITATIONS

5.1 FACILITIES

All measurement facilities used to collect the measurement data are located at

- No.199, Chunghsen Road, Hsintien City, Taipei Hsien, Taiwan, R.O.C.
Tel: 886-2-2217-0894 / Fax: 886-2-2217-1029
- No.11, Wugong 6th Rd., Wugu Dist., New Taipei City 248, Taiwan (R.O.C.)
Tel: 886-2-2299-9720 / Fax: 886-2-2298-4045
- No.81-1, Lane 210, Bade 2nd Rd., Lujhu Township, Taoyuan County 33841, TAIWAN, R.O.C.
Tel: 886-3-324-0332 / Fax: 886-3-324-5235



The sites are constructed in conformance with the requirements of ANSI C63.7, ANSI C63.10: 2013 and CISPR Publication 22.

All receiving equipment conforms to CISPR Publication 16-1, "Radio Interference Measuring Apparatus and Measurement Methods."

5.2 LABORATORY ACCREDITATIONS AND LISTING

The test facilities used to perform radiated and conducted emissions tests are accredited by American Association for Laboratory Accreditation Program for the specific scope accreditation under Lab Code: 0824-01 to perform Electromagnetic Interference tests according to FCC Part 15 and CISPR 22 requirements. In addition, the test facilities are listed with Industry Canada, Certification and Engineering Bureau, IC 2324G-1 for 3M Semi Anechoic Chamber A, IC 2324G-2 for 3M Semi Anechoic Chamber B.

5.3 TABLE OF ACCREDITATIONS AND LISTINGS

Country	Agency	Scope of Accreditation	Logo
USA	FCC	3M Semi Anechoic Chamber (FCC MRA: TW1039) to perform FCC Part 15 measurements	 FCC MRA: TW1039
Taiwan	TAF	LP0002, RTTE01, FCC Method-47 CFR Part 15 Subpart C, D, E, RSS-247, RSS-310 IDA TS SRD, AS/NZS 4268, AS/NZS 4771, TS 12.1 & 12.2, ETSI EN 300 440-1, ETSI EN 300 440-2, ETSI EN 300 328, ETSI EN 300 220-1, ETSI EN 300 220-2, ETSI EN 301 893, ETSI EN 301 489-1/3/7/17 FCC OET Bulletin 65 + Supplement C, EN 50360, EN 50361, EN 50371, RSS 102, EN 50383, EN 50385, EN 50392, IEC 62209, CNS 14958-1, CNS 14959 FCC Method -47 CFR Part 15 Subpart B IEC / EN 61000-3-2, IEC / EN 61000-3-3, IEC / EN 61000-4-2/3/4/5/6/8/11	
Canada	Industry Canada	3M Semi Anechoic Chamber (IC 2324G-1 / IC 2324G-2) to perform	 IC 2324G-1 IC 2324G-2

* No part of this report may be used to claim or imply product endorsement by A2LA or any agency of the US Government.

6 SETUP OF EQUIPMENT UNDER TEST

6.1 SETUP CONFIGURATION OF EUT

See test photographs attached in Appendix I for the actual connections between EUT and support equipment.

6.2 SUPPORT EQUIPMENT

No.	Device Type	Brand	Model	Series No.	FCC ID	Data Cable	Power Cord
	N/A						

Remark:

1. *All the equipment/cables were placed in the worst-case configuration to maximize the emission during the test.*
2. *Grounding was established in accordance with the manufacturer's requirements and conditions for the intended use.*

7 FCC PART 15 REQUIREMENTS

7.1 6DB BANDWIDTH

LIMIT

According to §15.407, systems using digital modulation techniques may operate in the 5725 - 5850 MHz bands. The minimum 6dB bandwidth shall be at least 500 kHz.

Test Configuration

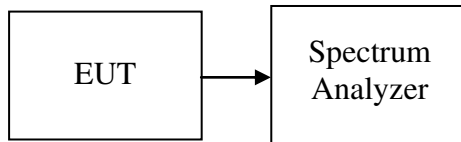

TEST PROCEDURE

1. Place the EUT on the table and set it in the transmitting mode.
2. Remove the antenna from the EUT and then connect a low loss RF cable from the antenna port to the spectrum analyzer.
3. Set the spectrum analyzer as RBW = 100kHz, VBW = 3 x RBW, Span = 50MHz, Sweep = auto.
4. Mark the peak frequency and -6dB (upper and lower) frequency.
5. Repeat until all the rest channels are investigated.

TEST RESULTS

No non-compliance noted

Test Data

Test mode: IEEE 802.11a mode

Channel	Frequency (MHz)	6dB Bandwidth (MHz)	Limit (kHz)	Result
Low	5745	16.1070	>500	PASS
Mid	5785	16.3240		PASS
High	5825	16.2370		PASS

Test mode: IEEE 802.11n HT 20 MHz mode / Chain 0

Channel	Frequency (MHz)	6dB Bandwidth (MHz)	Limit (kHz)	Result
Low	5745	17.5400	>500	PASS
Mid	5785	17.5400		PASS
High	5825	17.3230		PASS

Test mode: IEEE 802.11n HT 20 MHz mode / Chain 1

Channel	Frequency (MHz)	6dB Bandwidth (MHz)	Limit (kHz)	Result
Low	5745	17.5400	>500	PASS
Mid	5785	17.5400		PASS
High	5825	17.5400		PASS

Test mode: IEEE 802.11n HT 40 MHz mode / Chain 0

Channel	Frequency (MHz)	6dB Bandwidth (MHz)	Limit (kHz)	Result
Low	5755	35.6600	>500	PASS
High	5795	35.7700		PASS

Test mode: IEEE 802.11n HT 40 MHz mode / Chain 1

Channel	Frequency (MHz)	6dB Bandwidth (MHz)	Limit (kHz)	Result
Low	5755	35.5400	>500	PASS
High	5795	35.6600		PASS

Test Plot

IEEE 802.11a mode / 5745 ~ 5825MHz
6dB Bandwidth (CH Low)

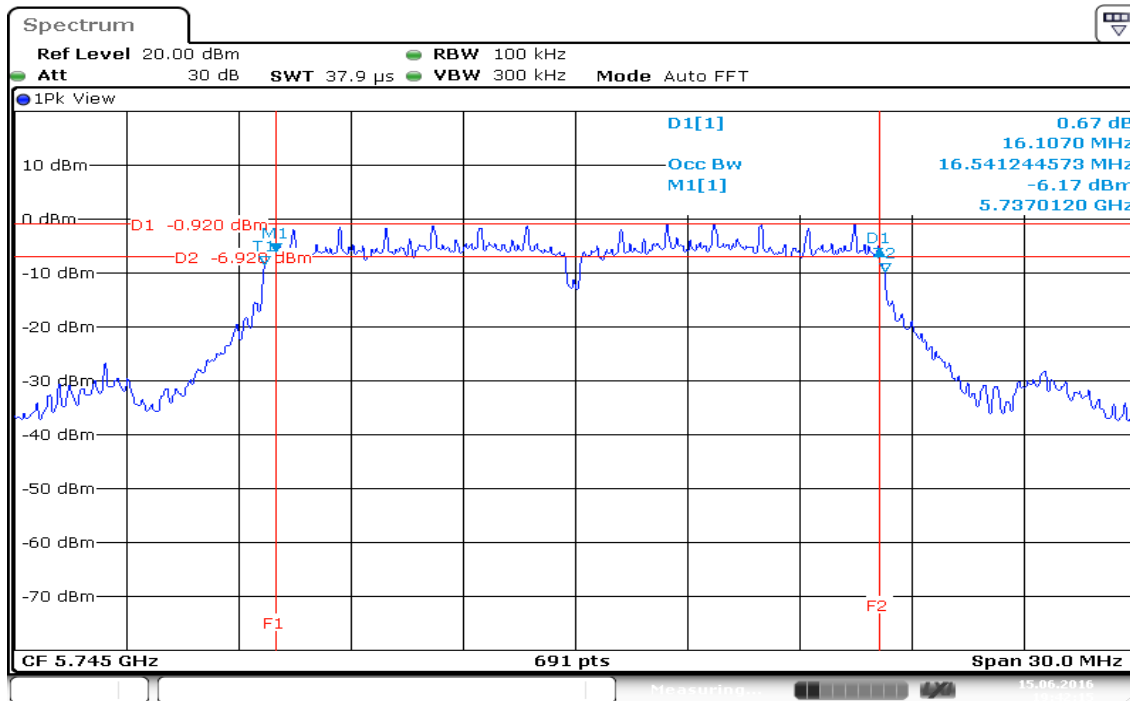

6dB Bandwidth (CH Mid)

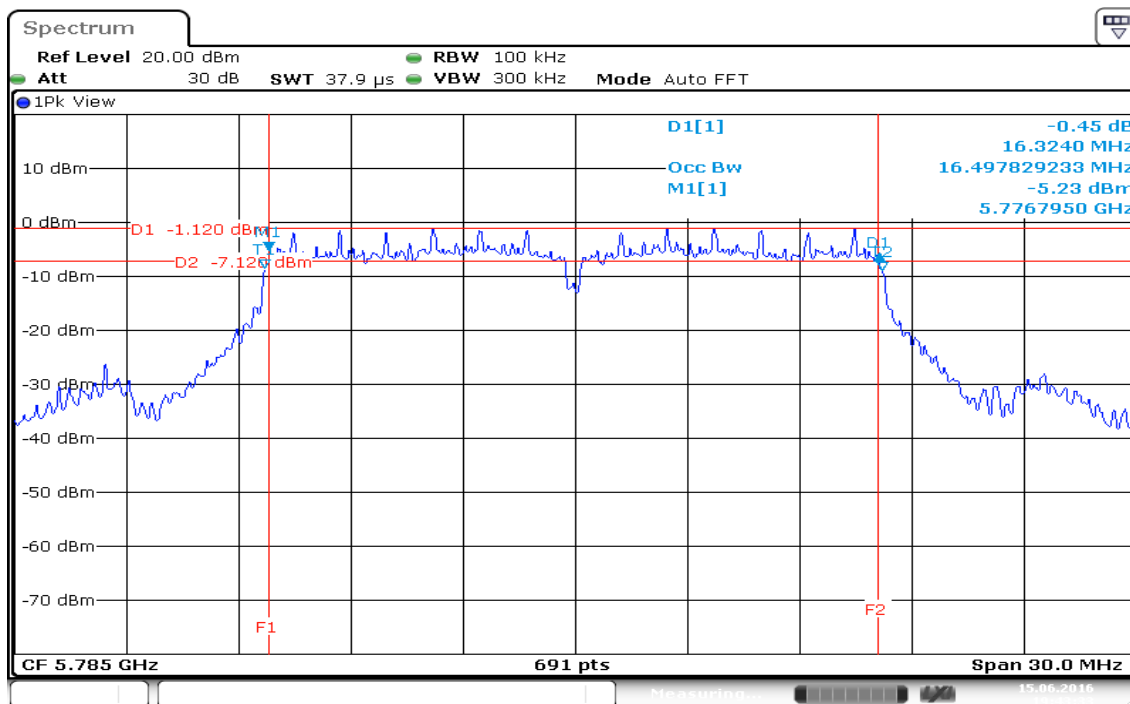

6dB Bandwidth (CH High)

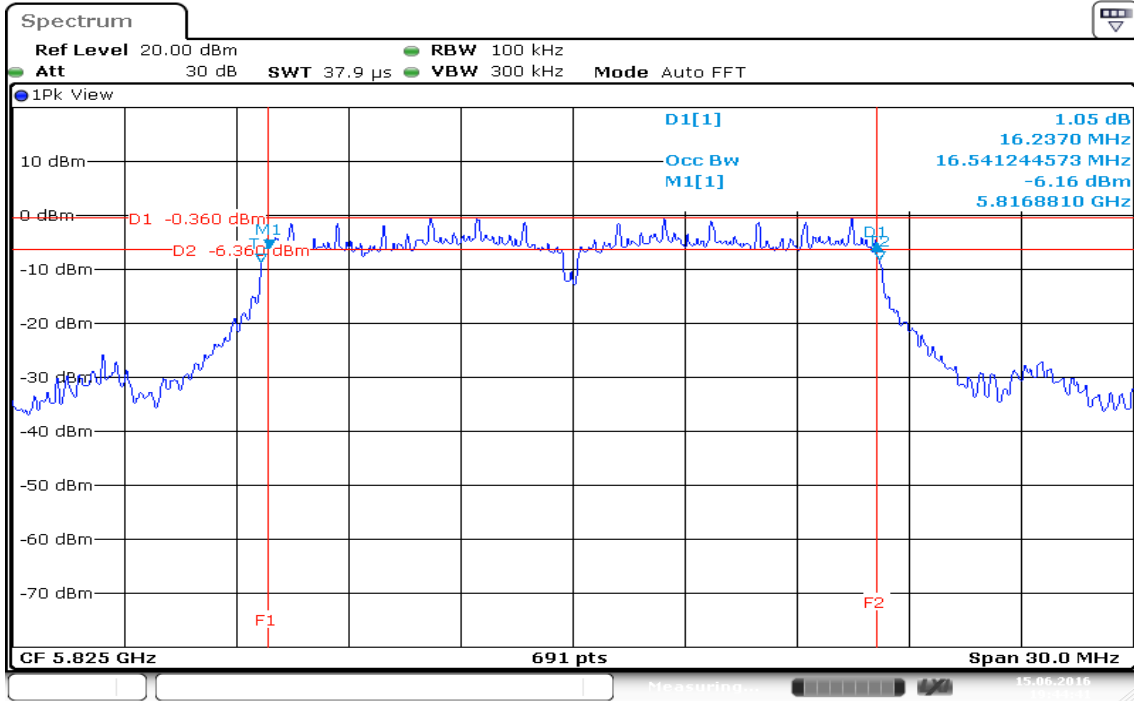

Date: 15.JUN.2016 19:44:41

IEEE 802.11n HT 20 MHz mode / 5745 ~ 5825MHz / Chain 0

6dB Bandwidth (CH Low)

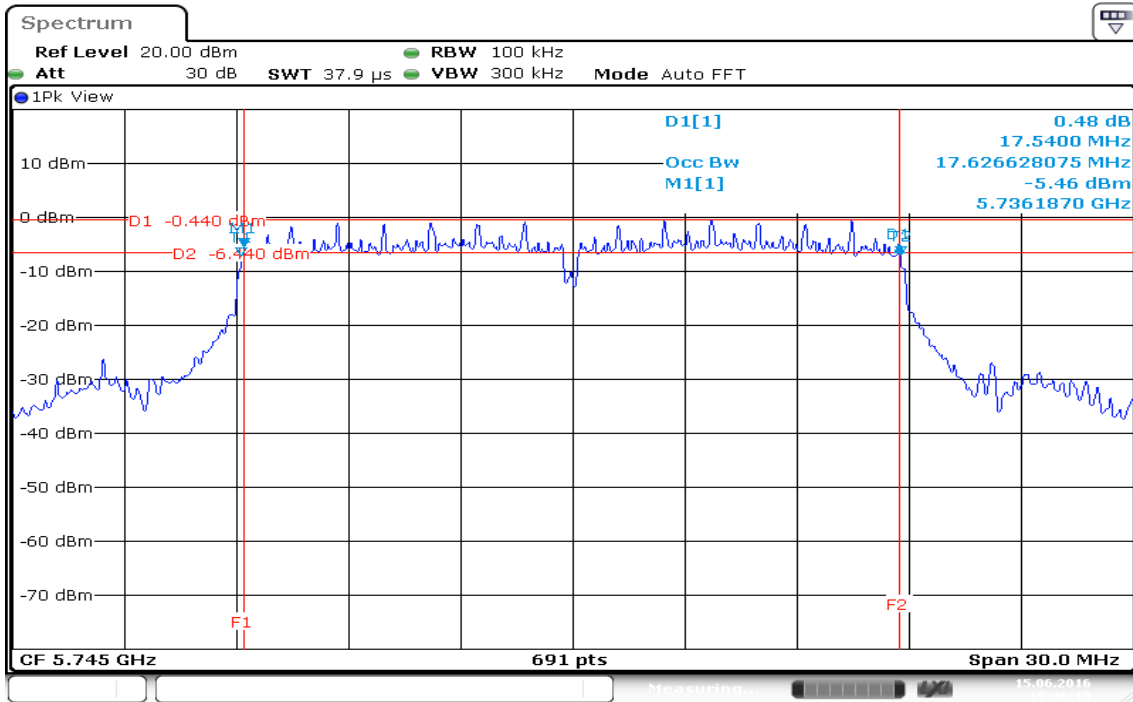

6dB Bandwidth (CH Mid)

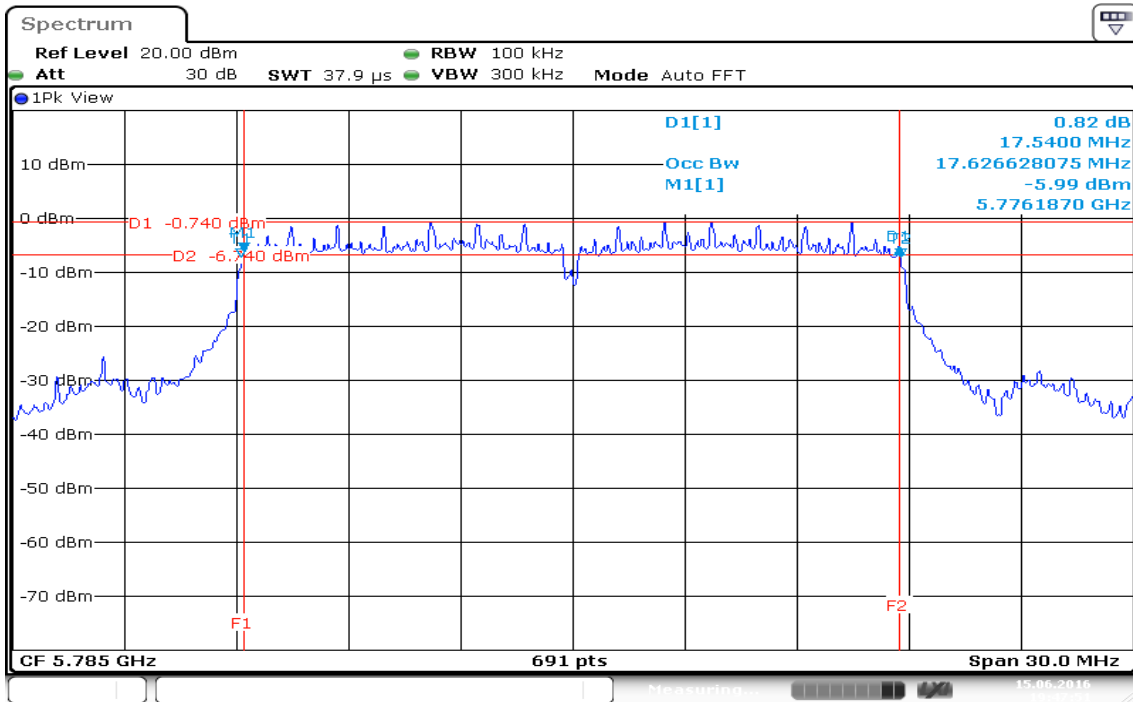

6dB Bandwidth (CH High)

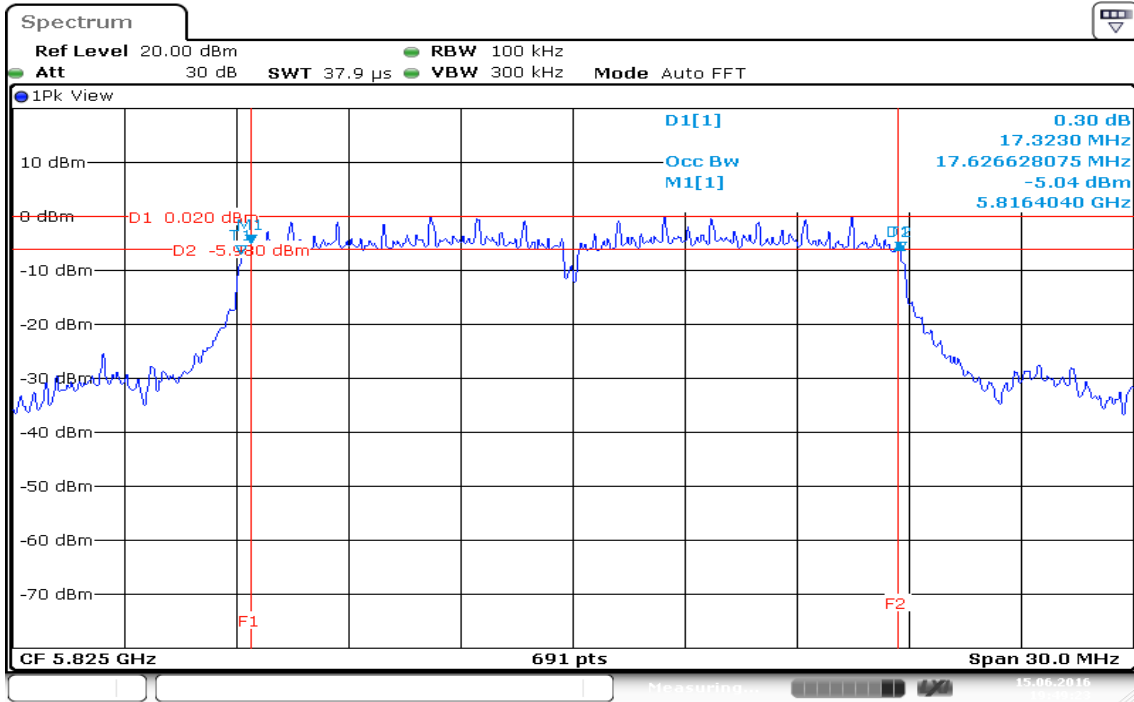

Date: 15.JUN.2016 19:49:23

IEEE 802.11n HT 20 MHz mode / 5745 ~ 5825MHz / Chain 1

6dB Bandwidth (CH Low)

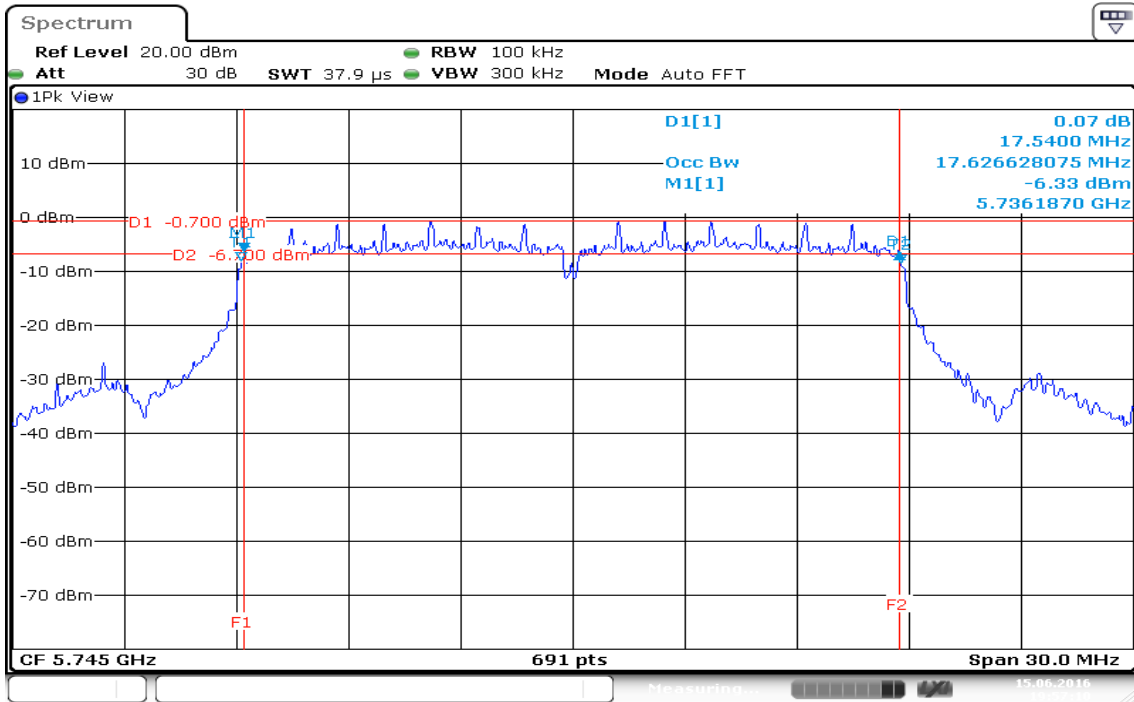

6dB Bandwidth (CH Mid)

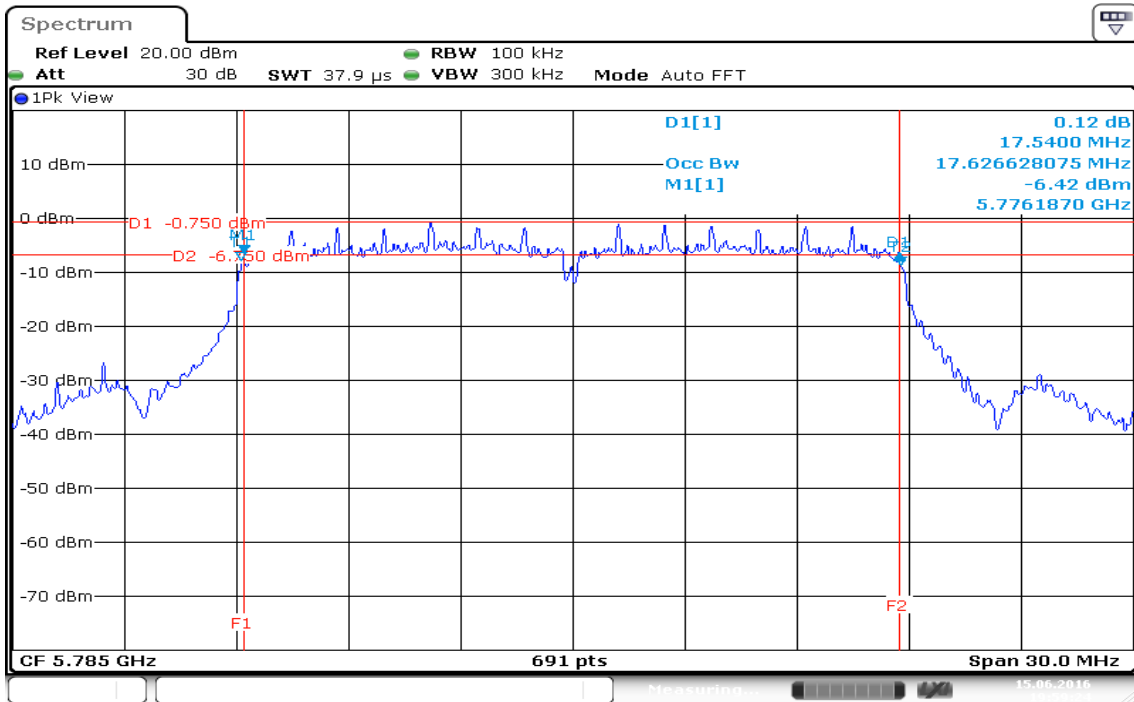

6dB Bandwidth (CH High)

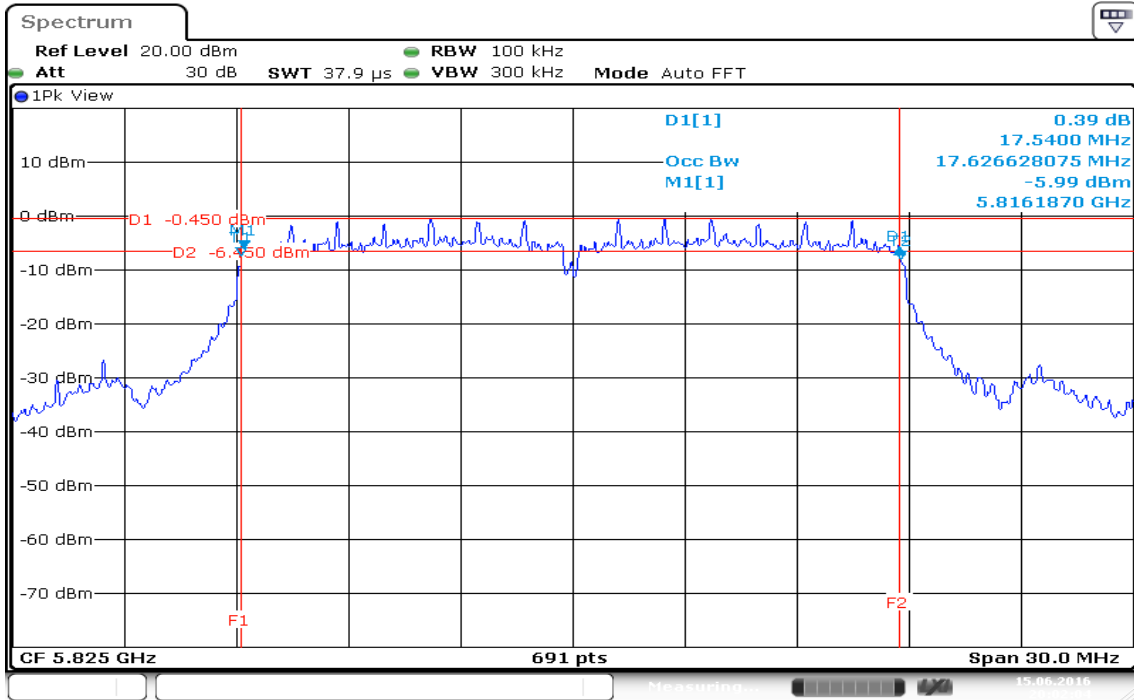

Date: 15.JUN.2016 20:02:04

IEEE 802.11n HT 40 MHz mode / 5755 ~ 5815MHz / Chain 0

6dB Bandwidth (CH Low)

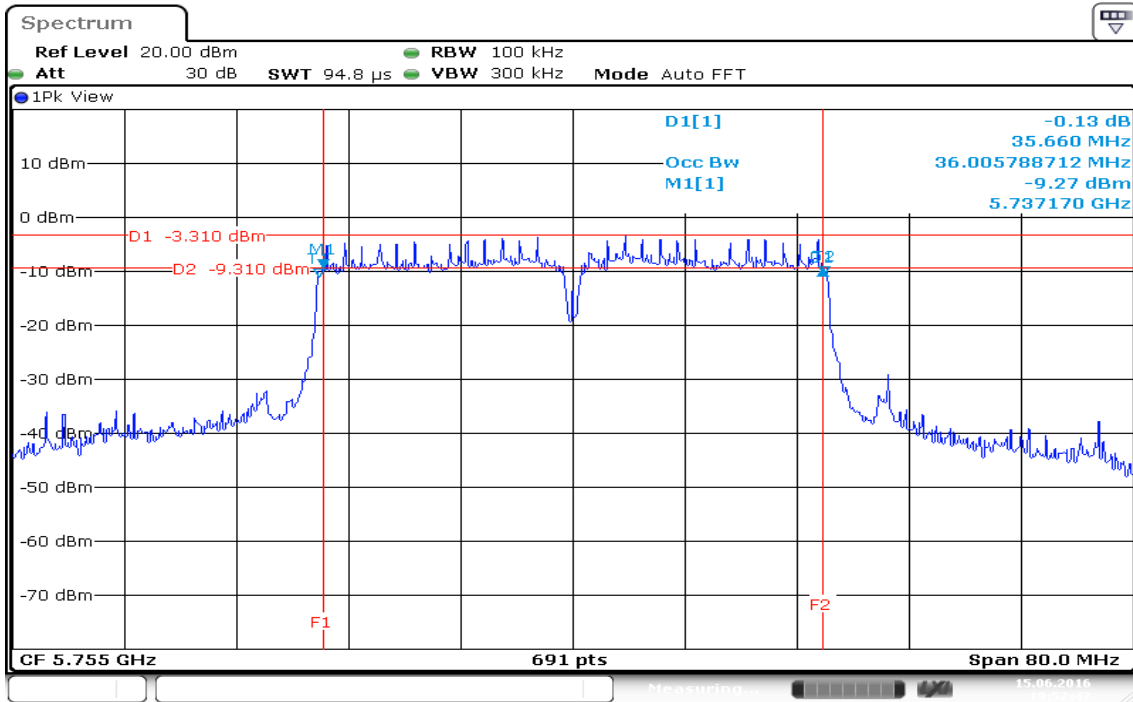

Date: 15.JUN.2016 19:52:42

6dB Bandwidth (CH High)

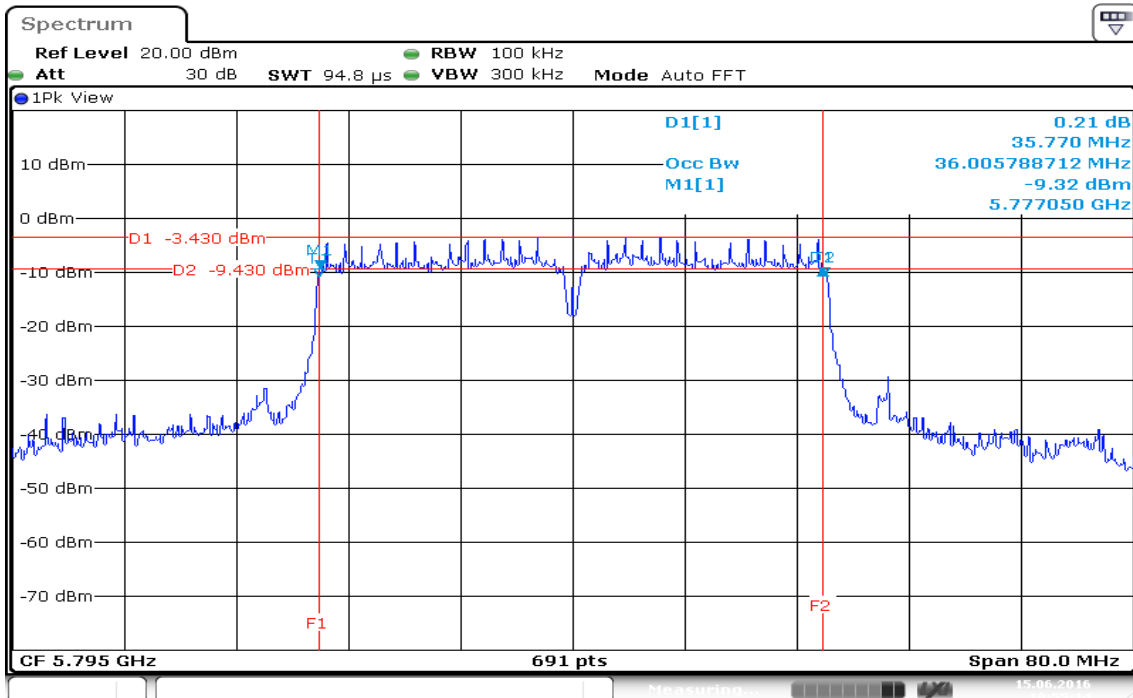

Date: 15.JUN.2016 19:55:14

IEEE 802.11n HT 40 MHz mode / 5755 ~ 5815MHz / Chain 1

6dB Bandwidth (CH Low)

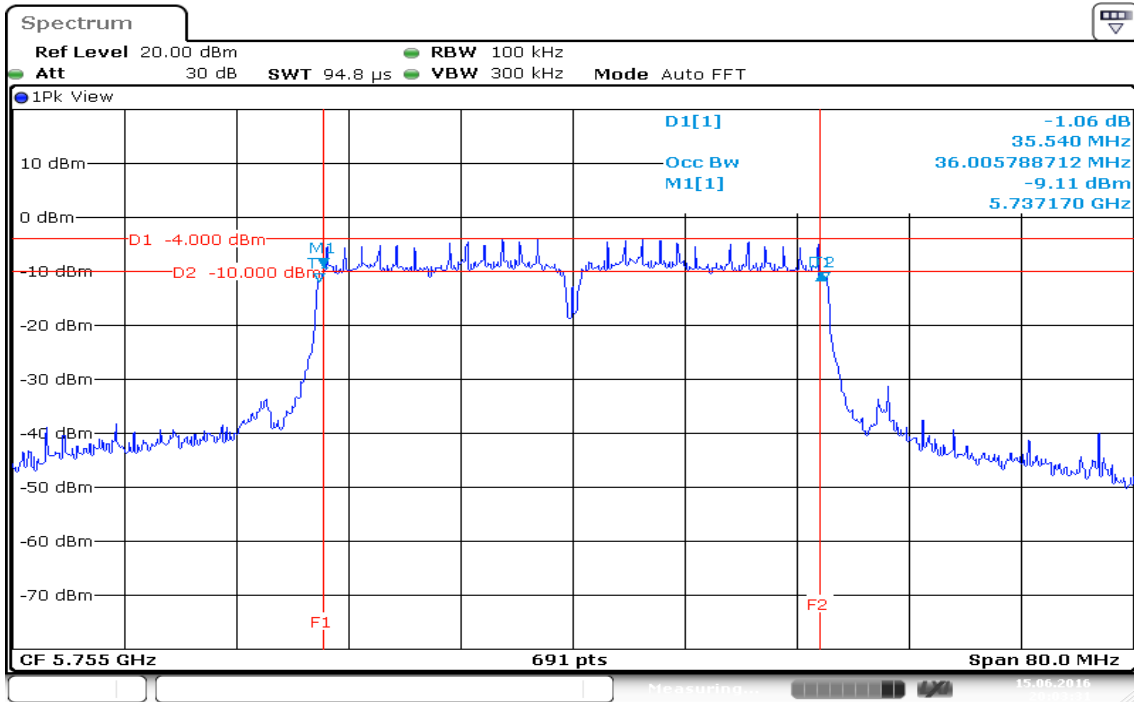

Date: 15.JUN.2016 20:03:31

6dB Bandwidth (CH High)

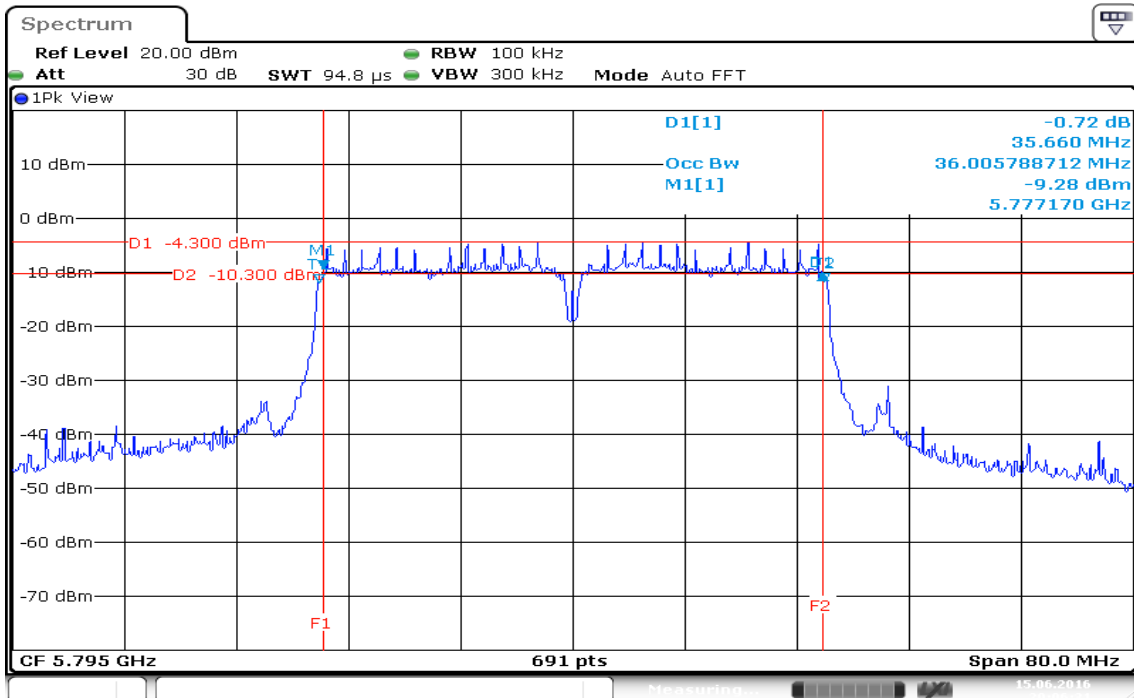

Date: 15.JUN.2016 20:06:31

7.2 MAXIMUM CONDUCTED OUTPUT POWER

LIMIT

The maximum peak output power of the intentional radiator shall not exceed the following:

1. According to §15.407, for systems using digital modulation in the bands of 5725-5850 MHz: 1 Watt.

Test Configuration

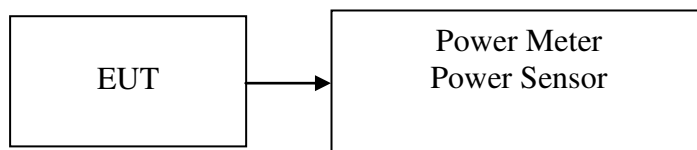

TEST PROCEDURE

The transmitter output is connected to the Power Meter. The Power Meter is set to the peak power detection.

TEST RESULTS

No non-compliance noted

Test Data

Test mode: IEEE 802.11a mode / 5745 ~ 5825MHz

Channel	Frequency (MHz)	Output Power (dBm)	Output Power (W)	Limit (dBm)
Low	5745	*13.57	0.0228	27.68
Mid	5785	13.06	0.0202	27.68
High	5825	12.99	0.0199	27.68

Test mode: IEEE 802.11n HT 20 MHz mode / 5745 ~ 5825MHz

Channel	Frequency (MHz)	Chain 0 Output Power (dBm)	Chain 1 Output Power (dBm)	Output Power (dBm)	Output Power (W)	Limit (dBm)
Low	5745	13.39	12.45	*16.22	0.0419	27.68
Mid	5785	12.91	12.21	15.85	0.0385	27.68
High	5825	12.89	11.89	15.70	0.0372	27.68

Test mode: IEEE 802.11n HT 40 MHz mode / 5755 ~ 5795MHz

Channel	Frequency (MHz)	Chain 0 Output Power (dBm)	Chain 1 Output Power (dBm)	Output Power (dBm)	Output Power (W)	Limit (dBm)
Low	5755	12.74	11.25	*15.58	0.0361	27.68
High	5795	12.46	11.01	14.81	0.0303	27.68

Remark:

1. Total PPSD (dBm) = $10 \cdot \text{LOG}(10^{(\text{Chain 0 PPSD} / 10)} + 10^{(\text{Chain 1 PPSD} / 10)})$
2. The maximum antenna gain is 8.32dBi; therefore the reduction due to antenna gain is 2.32dBi, so the limit is 27.68dBm.

7.3 BAND EDGES MEASUREMENT

LIMIT

According to §15.407(d), in any 100 kHz bandwidth outside the frequency bands in which the spread spectrum intentional radiator is operating, the radio frequency power that is produced by the intentional radiator shall be at least 20 dB below that in the 100 kHz bandwidth within the band that contains the highest level of the desired power, based on either an RF conducted or a radiated measurement, provided the transmitter demonstrates compliance with the peak conducted power limits. In addition, radiated emissions which fall in the restricted bands, as defined in §15.205(a), must also comply with the radiated emission limits specified in 15.209(a) (see Section 15.205(c)).

Test Configuration

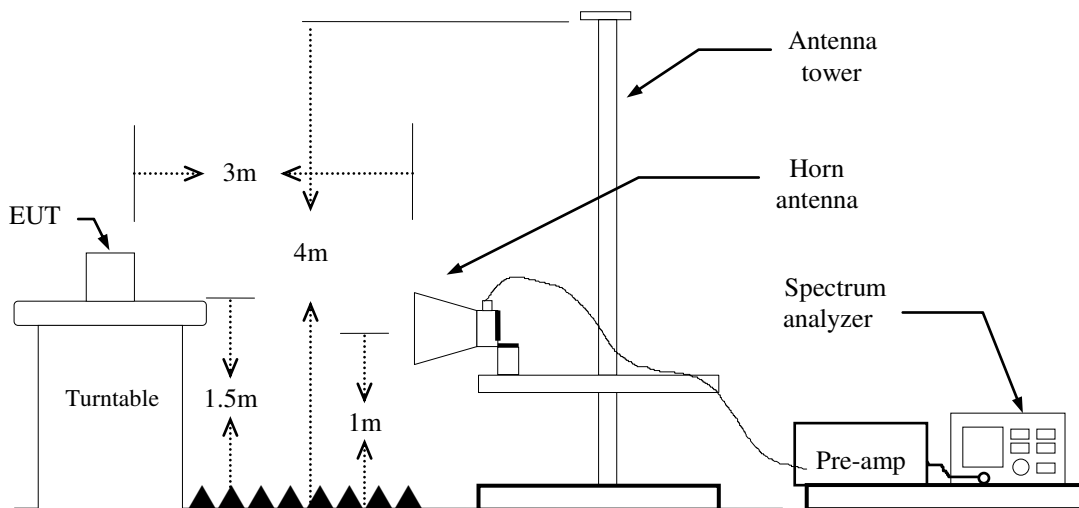

TEST PROCEDURE

1. The EUT is placed on a turntable, which is 1.5m above the ground plane.
2. The turntable shall be rotated for 360 degrees to determine the position of maximum emission level.
3. EUT is set 3m away from the receiving antenna, which is varied from 1m to 4m to find out the highest emission.
4. Set the spectrum analyzer in the following setting in order to capture the lower and upper band-edges of the emission:
 - (a) PEAK: RBW=VBW=1MHz / Sweep=AUTO
 - (b) AVERAGE: RBW=1MHz,
if duty cycle $\geq 98\%$, VBW=10Hz.
if duty cycle $< 98\%$ VBW=1/T.
IEEE 802.11a mode: $\geq 94\%$, VBW=750Hz
IEEE 802.11n HT 20 MHz mode: $\geq 94\%$, VBW=750Hz
IEEE 802.11n HT 40 MHz mode: $\geq 87\%$, VBW=1.5kHz
5. Repeat the procedures until all the PEAK and AVERAGE versus POLARIZATION are measured.
6. Result = Spectrum Reading + cable loss(spectrum to Amp) - Amp Gain + Cable loss(Amp to receive Ant)+ Receive Ant

TEST RESULTS

Refer to attach spectrum analyzer data chart.

Band Edges (IEEE 802.11a mode / CH Low)

Detector mode: Peak

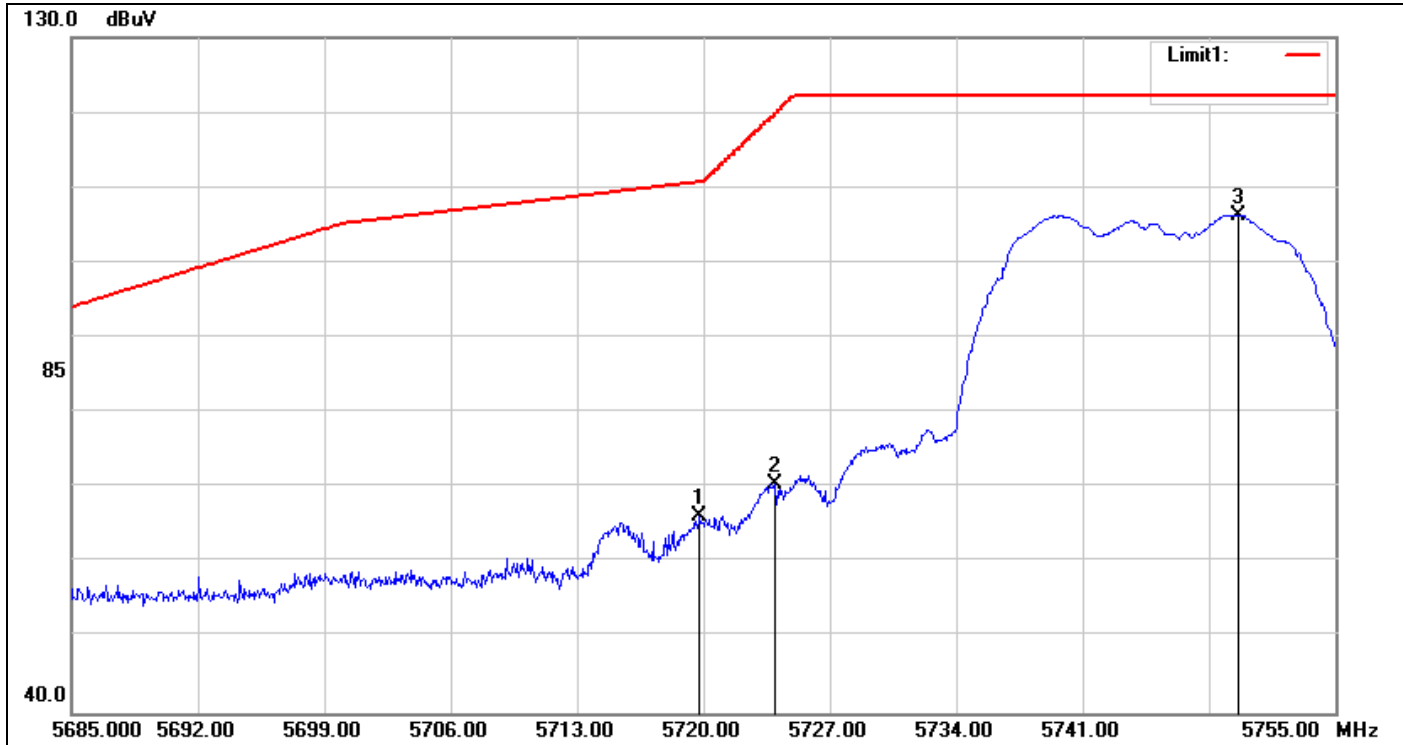

No.	Frequency (MHz)	Reading (dBuV)	Correct Factor (dB)	Result (dBuV)	Limit (dBuV)	Margin (dB)	Remark
1	5719.790	60.13	6.19	66.32	110.74	-44.42	peak
2	5723.990	64.34	6.20	70.54	119.90	-49.36	peak
3	5749.610	100.06	6.31	106.37	-	-	peak

Detector mode: Average

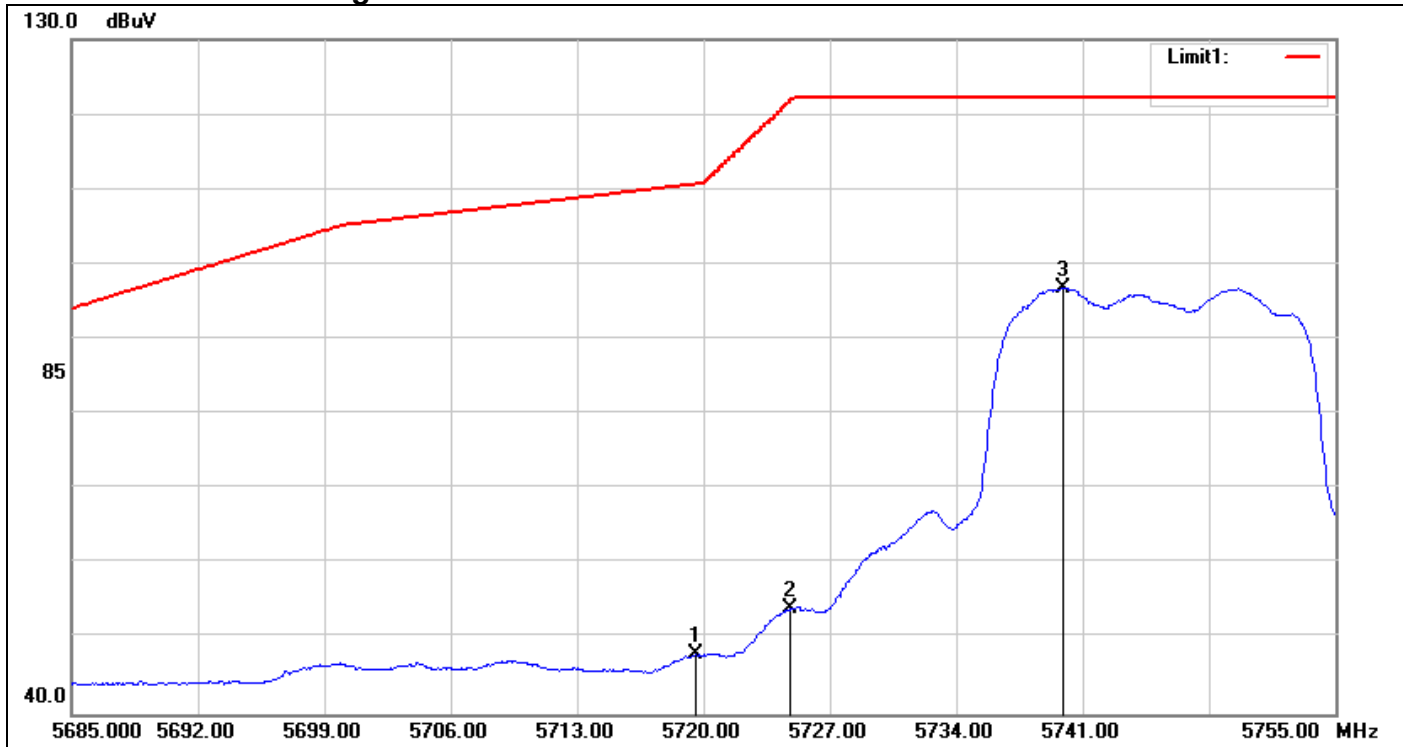

No.	Frequency (MHz)	Reading (dBuV)	Correct Factor(dB)	Result (dBuV)	Limit (dBuV)	Margin (dB)	Remark
1	5719.580	41.74	6.19	47.93	110.68	-62.75	AVG
2	5724.830	47.95	6.21	54.16	121.81	-67.65	AVG
3	5739.950	90.65	6.27	96.92	-	-	AVG

Band Edges (IEEE 802.11a mode / CH Mid)

Detector mode: Peak

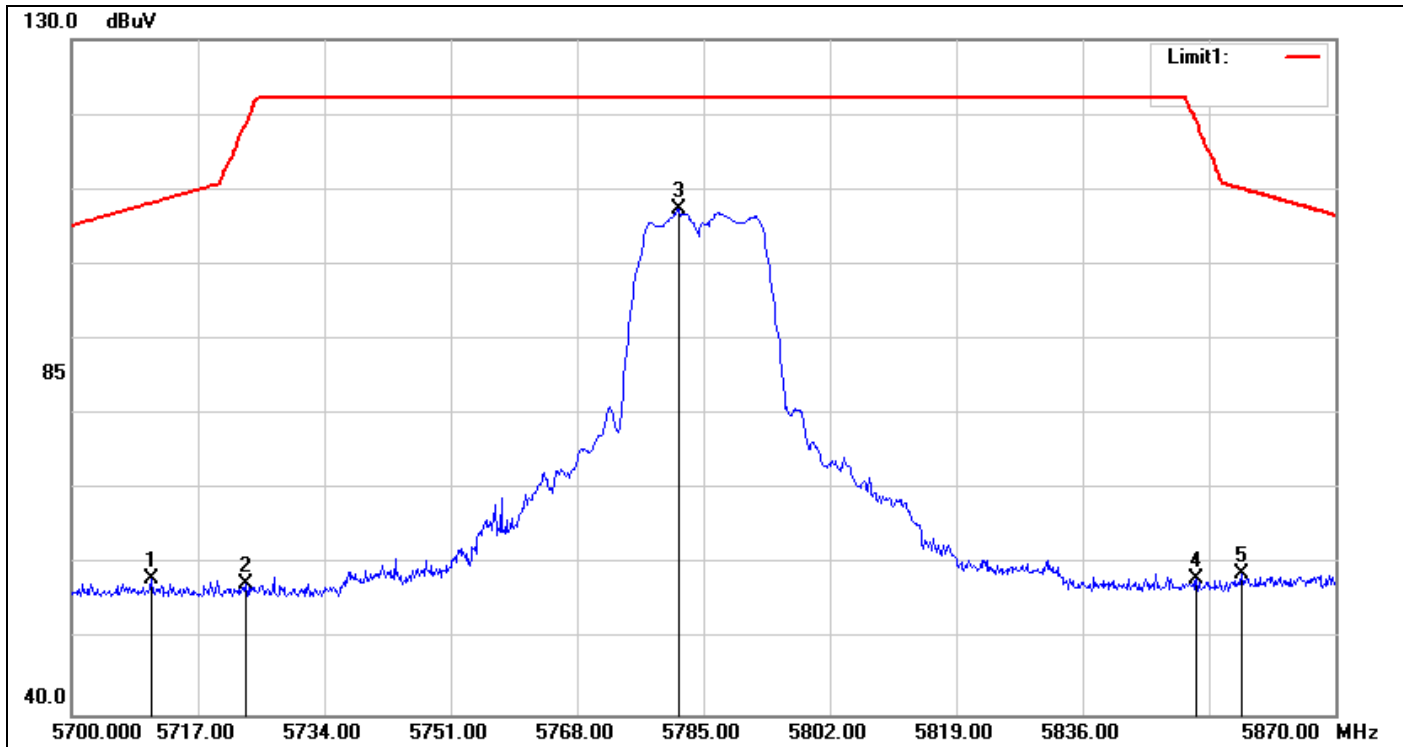

No.	Frequency (MHz)	Reading (dBuV)	Correct Factor(dB)	Result (dBuV)	Limit (dBuV)	Margin (dB)	Remark
1	5710.710	51.93	6.15	58.08	108.20	-50.12	peak
2	5723.460	51.21	6.20	57.41	118.69	-61.28	peak
3	5781.600	100.87	6.45	107.32	-	-	peak
4	5851.300	51.30	6.75	58.05	119.24	-61.19	peak
5	5857.420	51.98	6.77	58.75	110.12	-51.37	peak

Detector mode: Average

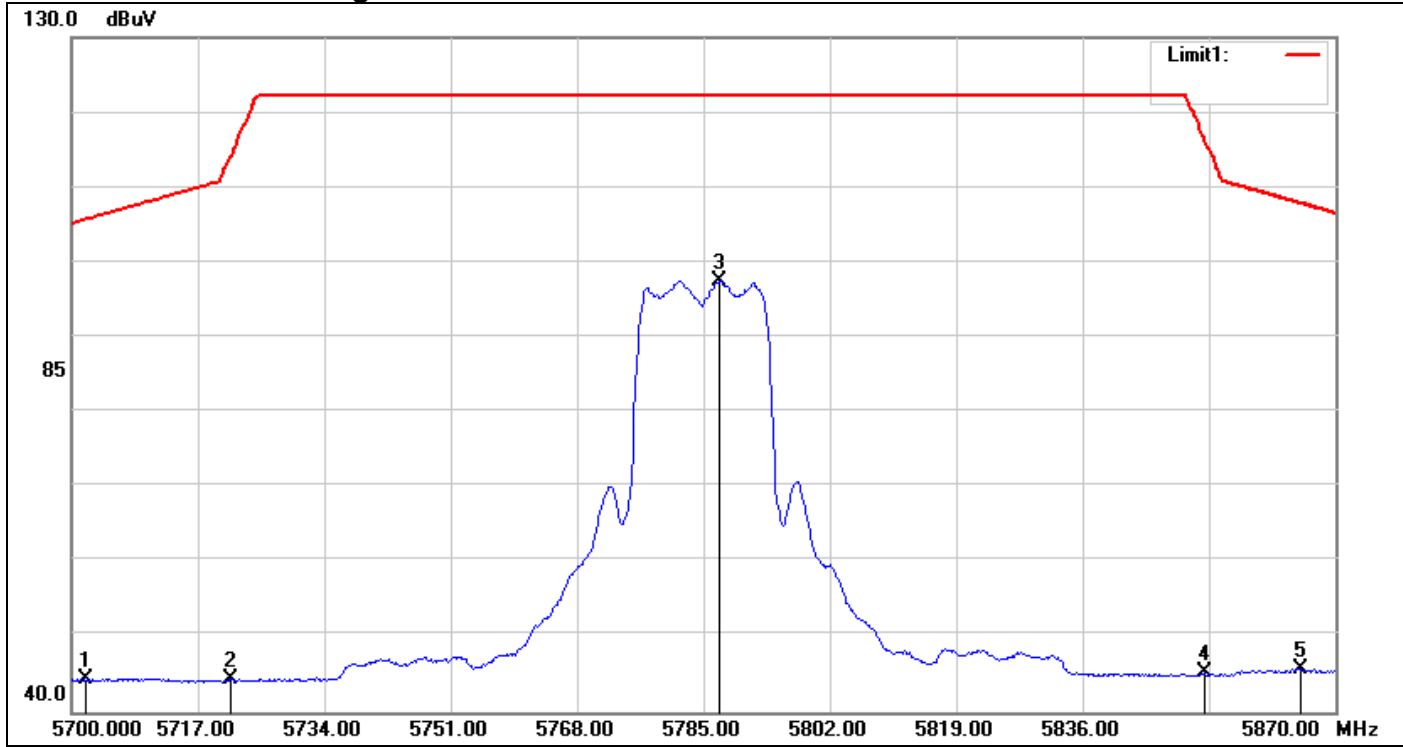

No.	Frequency (MHz)	Reading (dBuV)	Correct Factor(dB)	Result (dBuV)	Limit (dBuV)	Margin (dB)	Remark
1	5701.870	38.39	6.11	44.50	105.72	-61.22	AVG
2	5721.420	38.24	6.19	44.43	114.04	-69.61	AVG
3	5787.210	90.98	6.47	97.45	-	-	AVG
4	5852.490	38.44	6.75	45.19	116.52	-71.33	AVG
5	5865.240	38.96	6.81	45.77	107.93	-62.16	AVG

Band Edges (IEEE 802.11a mode / CH High)

Detector mode: Peak

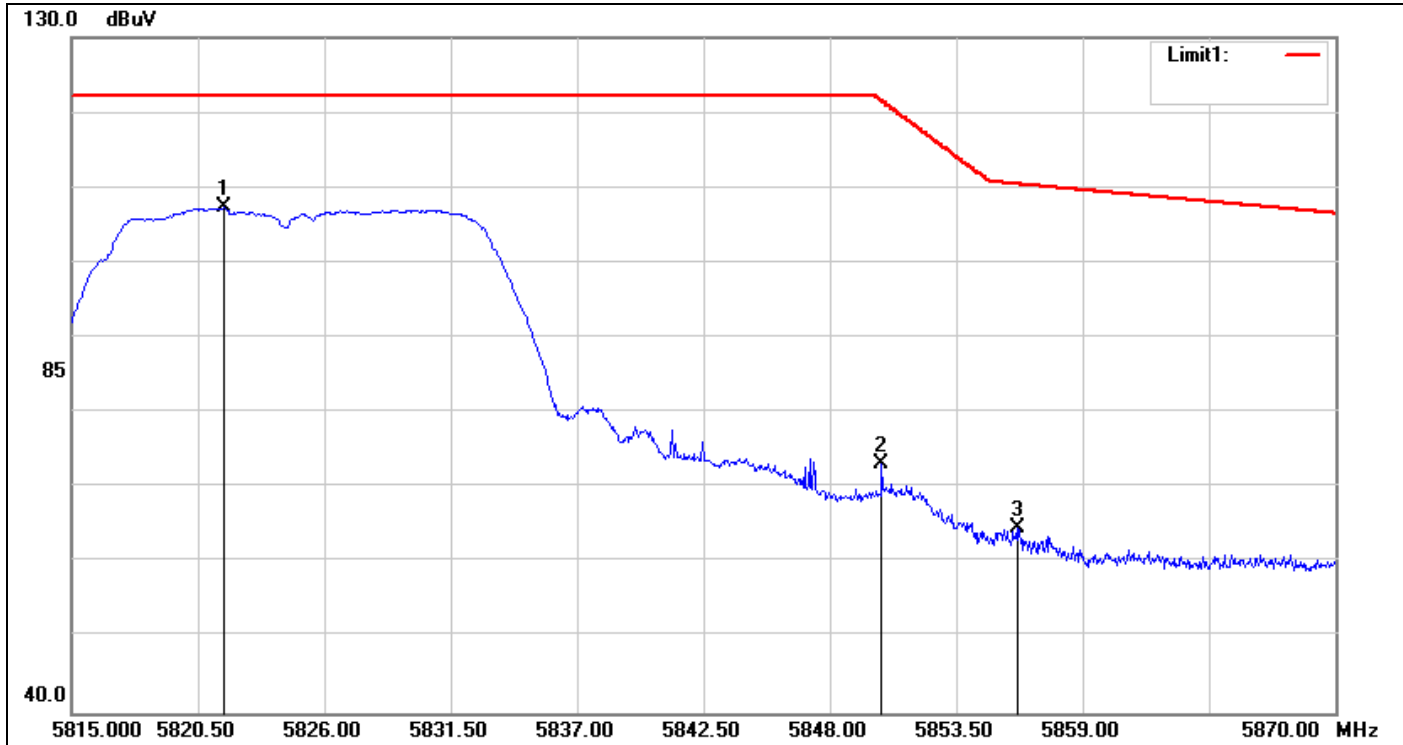

No.	Frequency (MHz)	Reading (dBuV)	Correct Factor (dB)	Result (dBuV)	Limit (dBuV)	Margin (dB)	Remark
1	5821.600	100.66	6.62	107.28	-	-	peak
2	5850.255	66.47	6.74	73.21	121.62	-48.41	peak
3	5856.140	57.91	6.77	64.68	110.48	-45.80	peak

Detector mode: Average

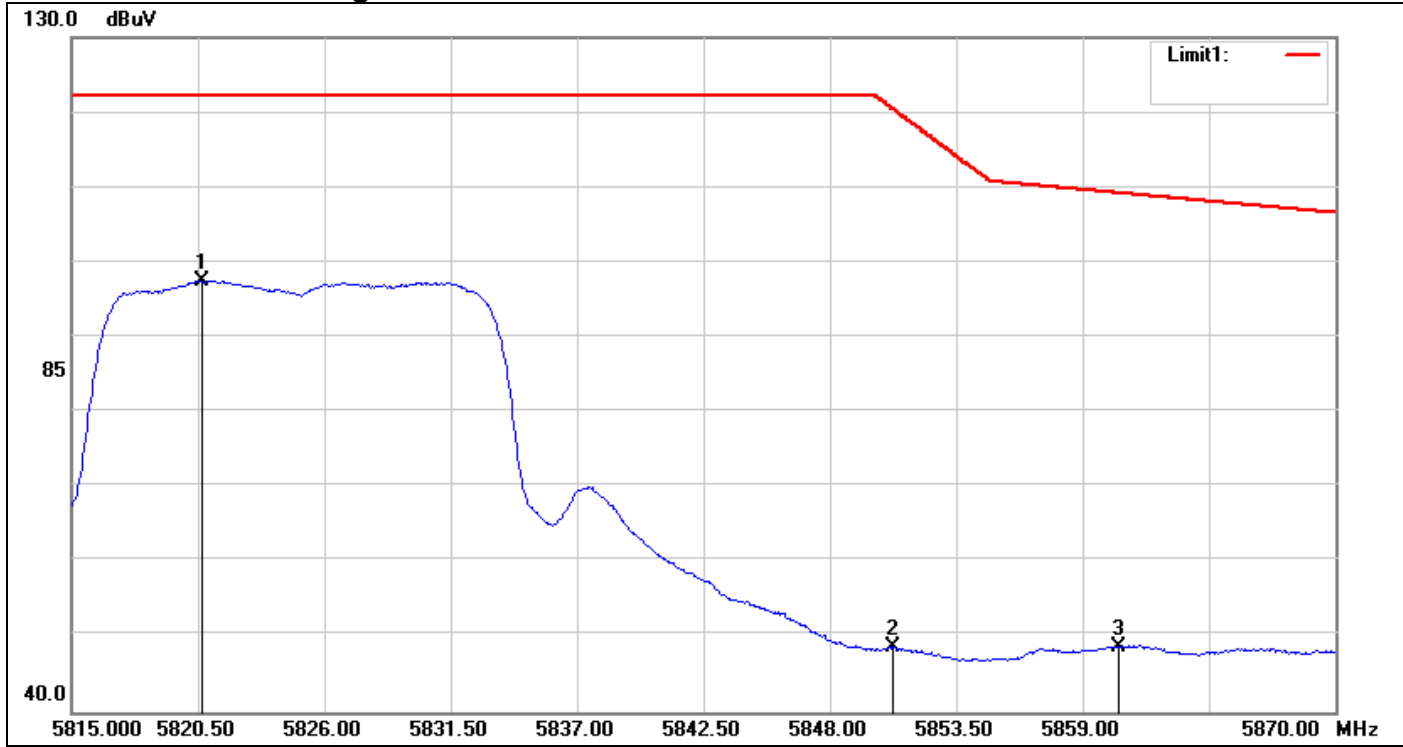

No.	Frequency (MHz)	Reading (dBuV)	Correct Factor(dB)	Result (dBuV)	Limit (dBuV)	Margin (dB)	Remark
1	5820.665	90.97	6.62	97.59	-	-	AVG
2	5850.750	41.92	6.74	48.66	120.49	-71.83	AVG
3	5860.595	41.95	6.79	48.74	109.23	-60.49	AVG

Band Edges (IEEE 802.11n HT 20 MHz mode / CH Low)

Detector mode: Peak

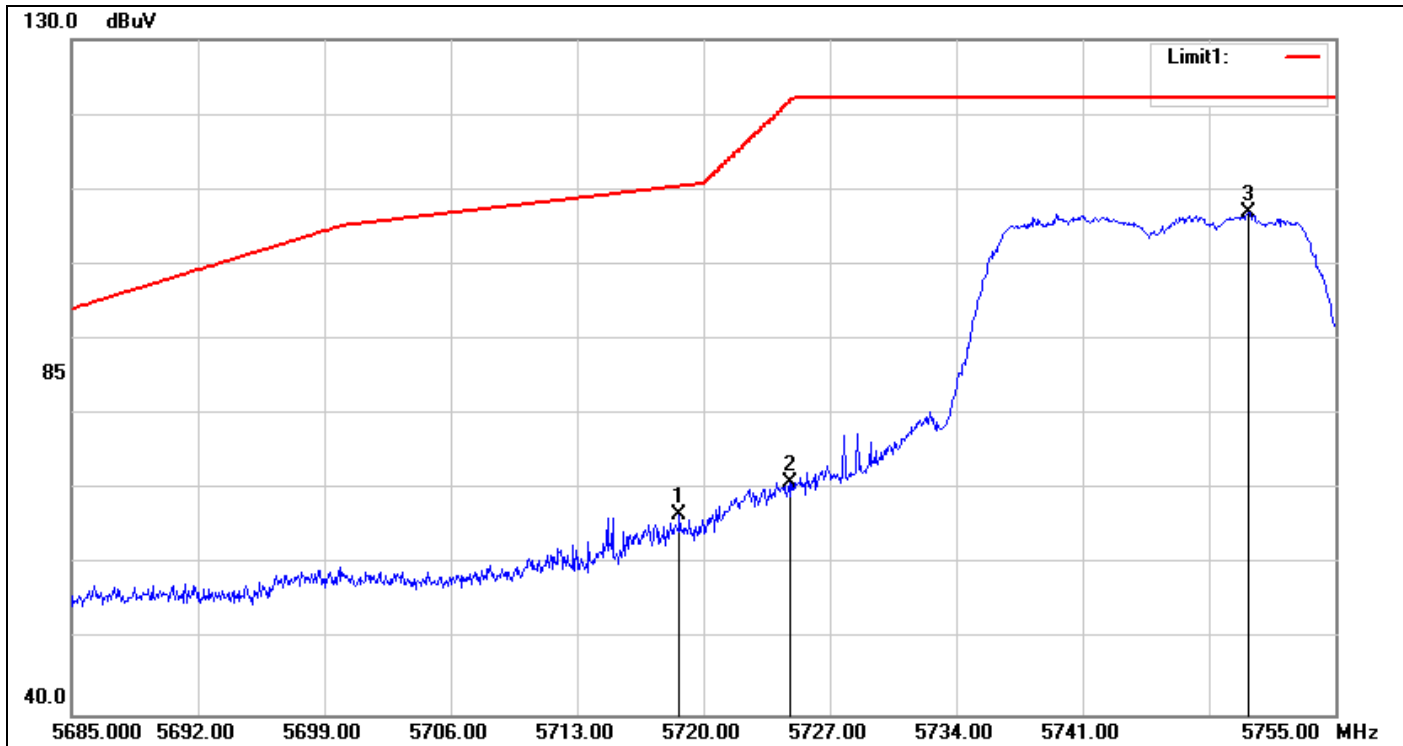

No.	Frequency (MHz)	Reading (dBuV)	Correct Factor(dB)	Result (dBuV)	Limit (dBuV)	Margin (dB)	Remark
1	5718.670	60.56	6.18	66.74	110.43	-43.69	peak
2	5724.760	64.76	6.21	70.97	121.65	-50.68	peak
3	5750.170	100.71	6.32	107.03	-	-	peak

Detector mode: Average

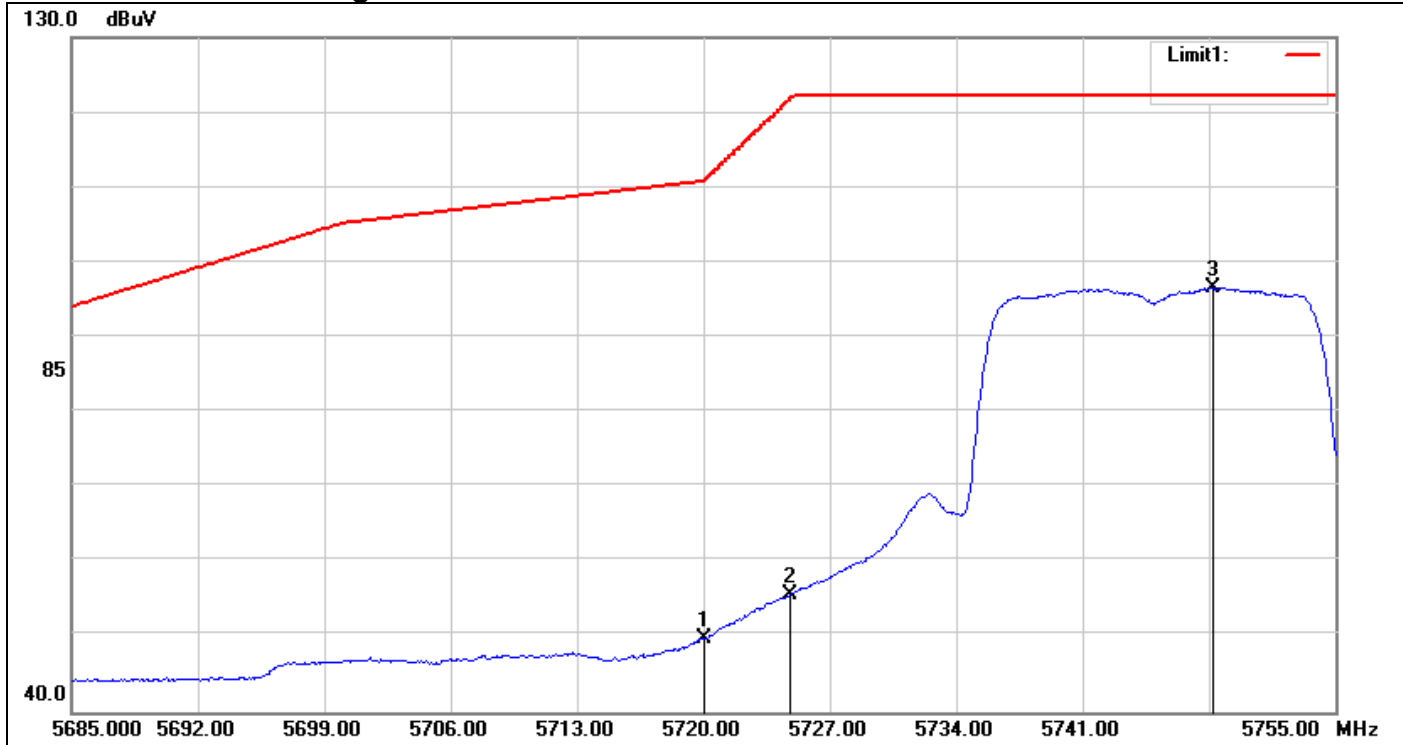

No.	Frequency (MHz)	Reading (dBuV)	Correct Factor(dB)	Result (dBuV)	Limit (dBuV)	Margin (dB)	Remark
1	5720.070	43.66	6.19	49.85	110.96	-61.11	AVG
2	5724.830	49.53	6.21	55.74	121.81	-66.07	AVG
3	5748.210	90.37	6.31	96.68	-	-	AVG

Band Edges (IEEE 802.11n HT 20 MHz mode / CH Mid)

Detector mode: Peak

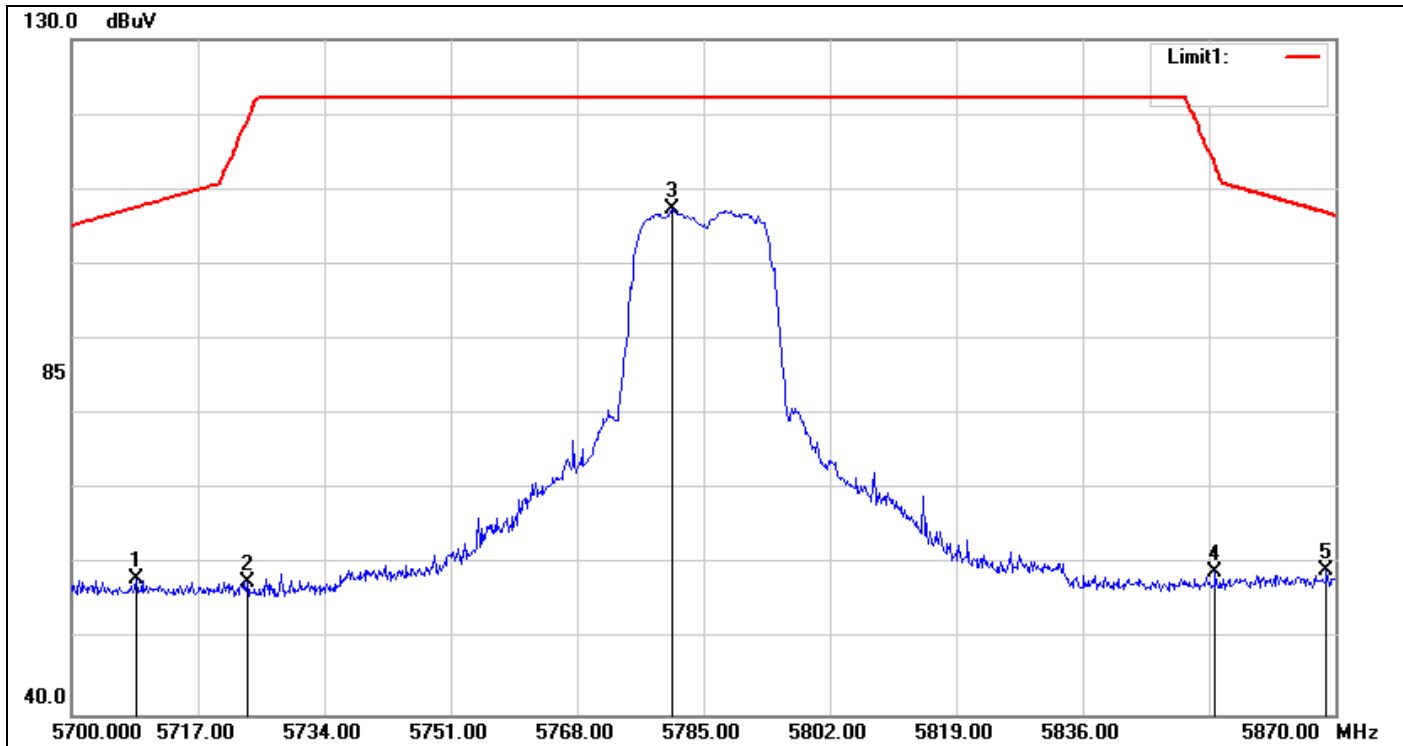

No.	Frequency (MHz)	Reading (dBuV)	Correct Factor(dB)	Result (dBuV)	Limit (dBuV)	Margin (dB)	Remark
1	5708.670	51.91	6.14	58.05	107.63	-49.58	peak
2	5723.630	51.53	6.20	57.73	119.08	-61.35	peak
3	5780.750	100.94	6.45	107.39	-	-	peak
4	5853.850	52.15	6.76	58.91	113.42	-54.51	peak
5	5868.810	52.52	6.82	59.34	106.93	-47.59	peak

Detector mode: Average

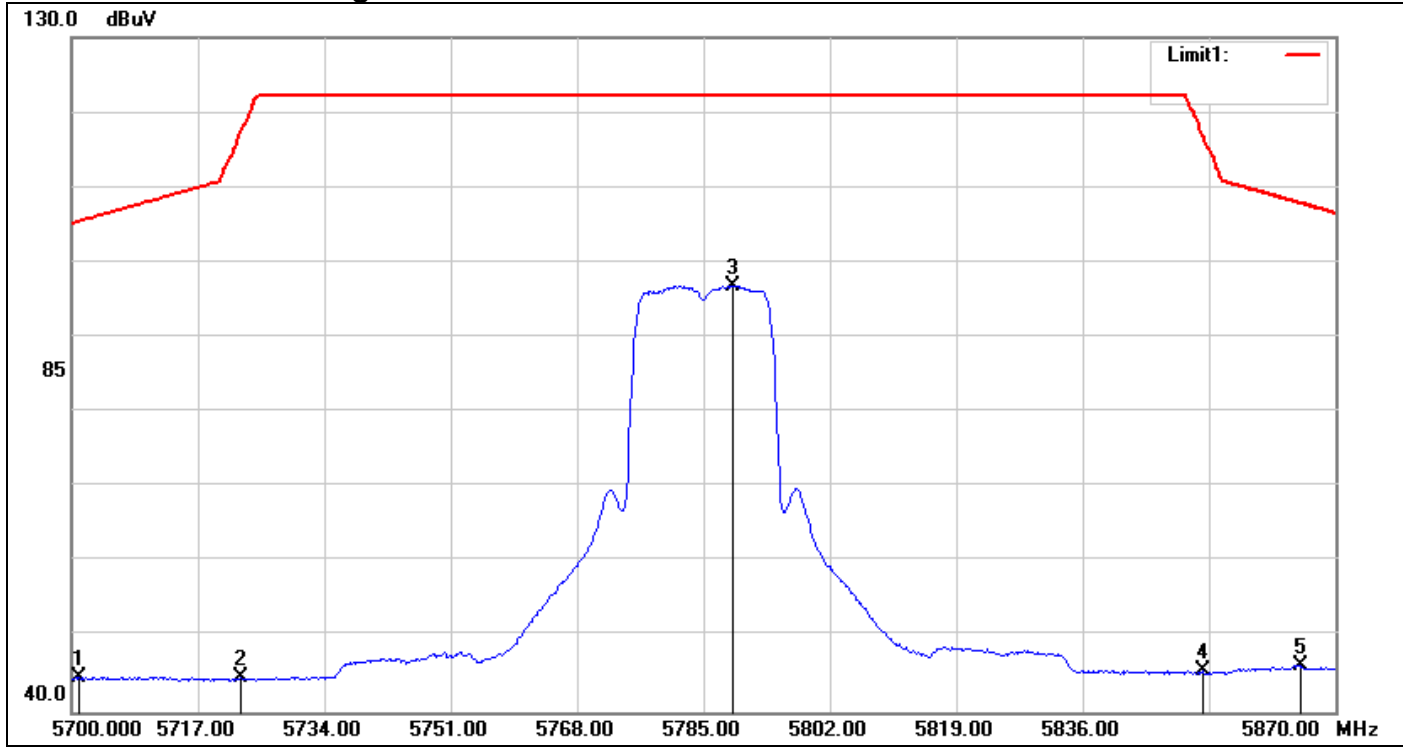

No.	Frequency (MHz)	Reading (dBuV)	Correct Factor(dB)	Result (dBuV)	Limit (dBuV)	Margin (dB)	Remark
1	5701.020	38.55	6.11	44.66	105.49	-60.83	AVG
2	5722.780	38.36	6.20	44.56	117.14	-72.58	AVG
3	5788.910	90.36	6.48	96.84	-	-	AVG
4	5852.150	38.70	6.75	45.45	117.30	-71.85	AVG
5	5865.240	39.39	6.81	46.20	107.93	-61.73	AVG

Band Edges (IEEE 802.11n HT 20 MHz mode / CH High)

Detector mode: Peak

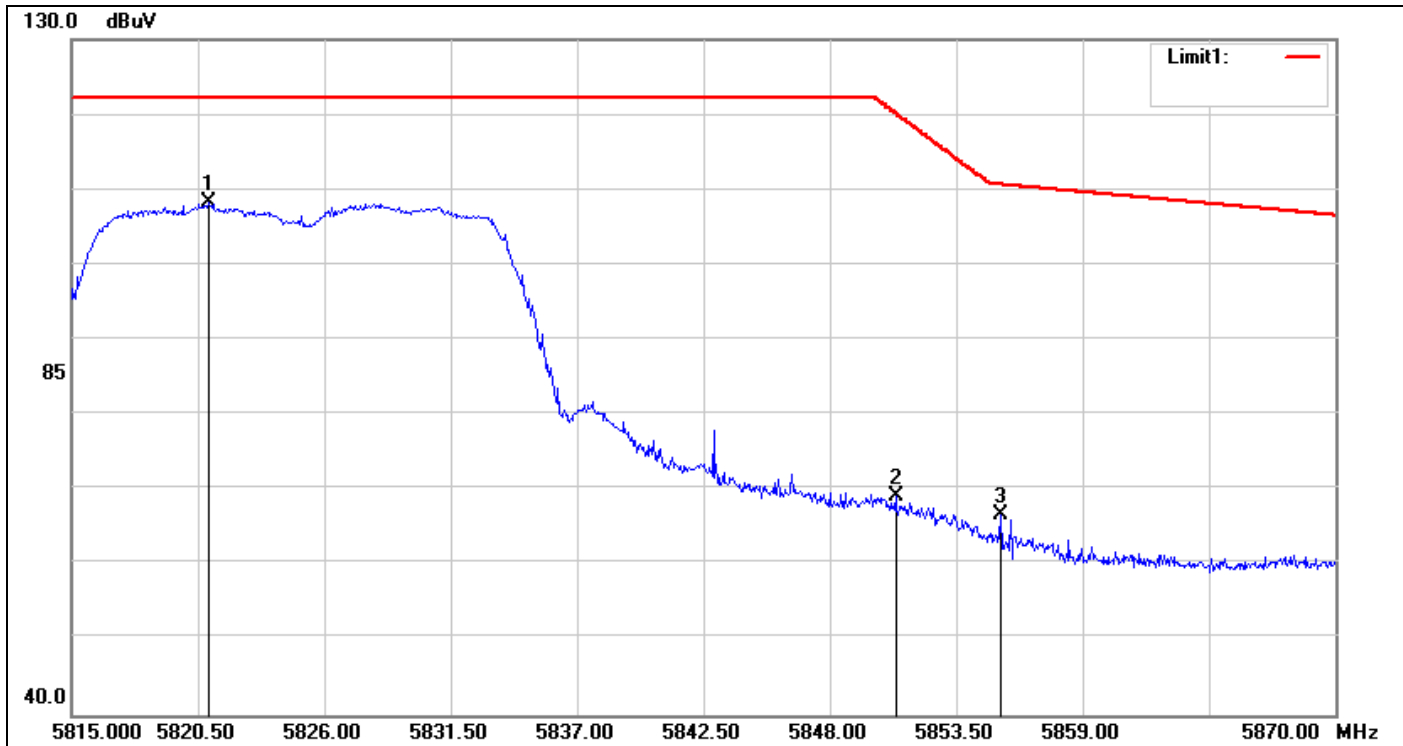

No.	Frequency (MHz)	Reading (dBuV)	Correct Factor(dB)	Result (dBuV)	Limit (dBuV)	Margin (dB)	Remark
1	5820.995	101.76	6.62	108.38	-	-	peak
2	5850.860	62.38	6.74	69.12	120.24	-51.12	peak
3	5855.425	59.95	6.76	66.71	110.68	-43.97	peak

Detector mode: Average

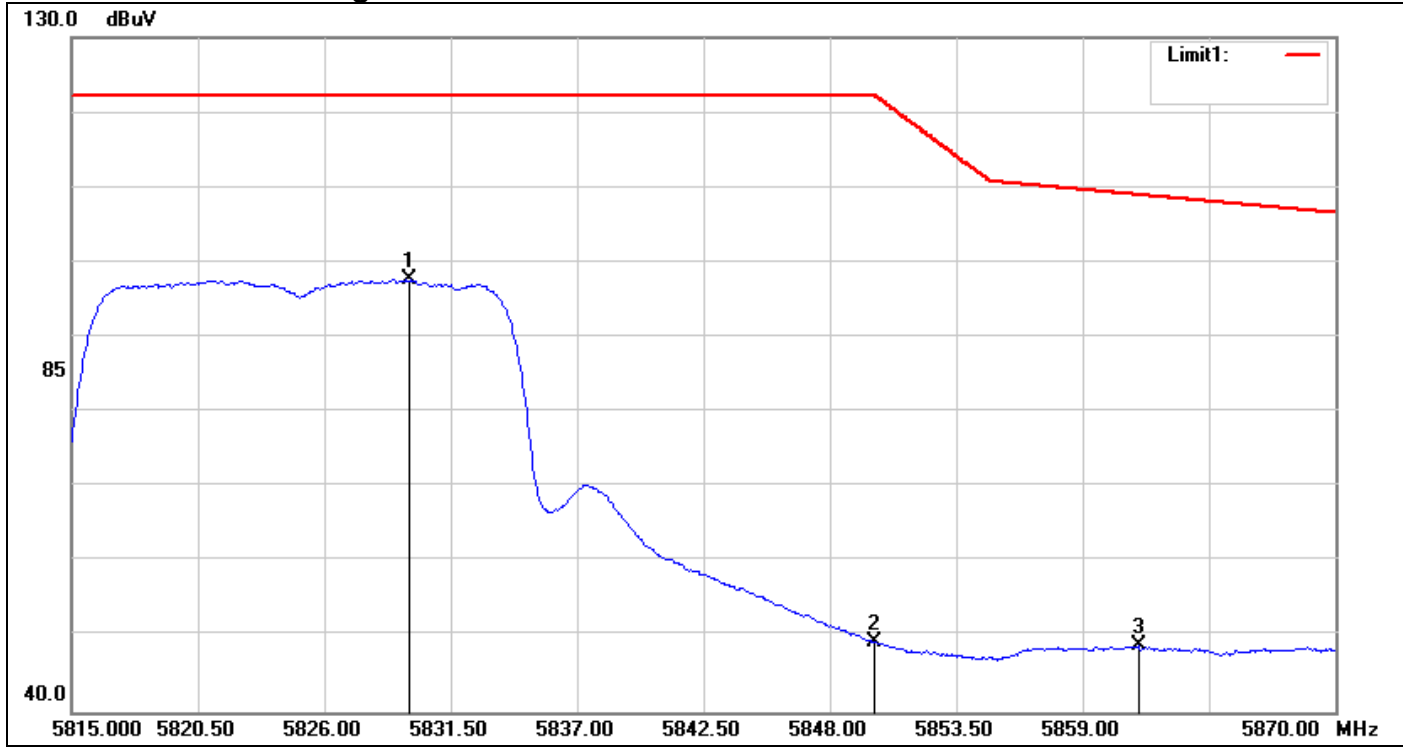

No.	Frequency (MHz)	Reading (dBuV)	Correct Factor(dB)	Result (dBuV)	Limit (dBuV)	Margin (dB)	Remark
1	5829.740	90.99	6.65	97.64	-	-	AVG
2	5849.980	42.55	6.74	49.29	122.20	-72.91	AVG
3	5861.420	41.99	6.79	48.78	109.00	-60.22	AVG

Band Edges (IEEE 802.11n HT 40 MHz mode / CH Low)

Detector mode: Peak

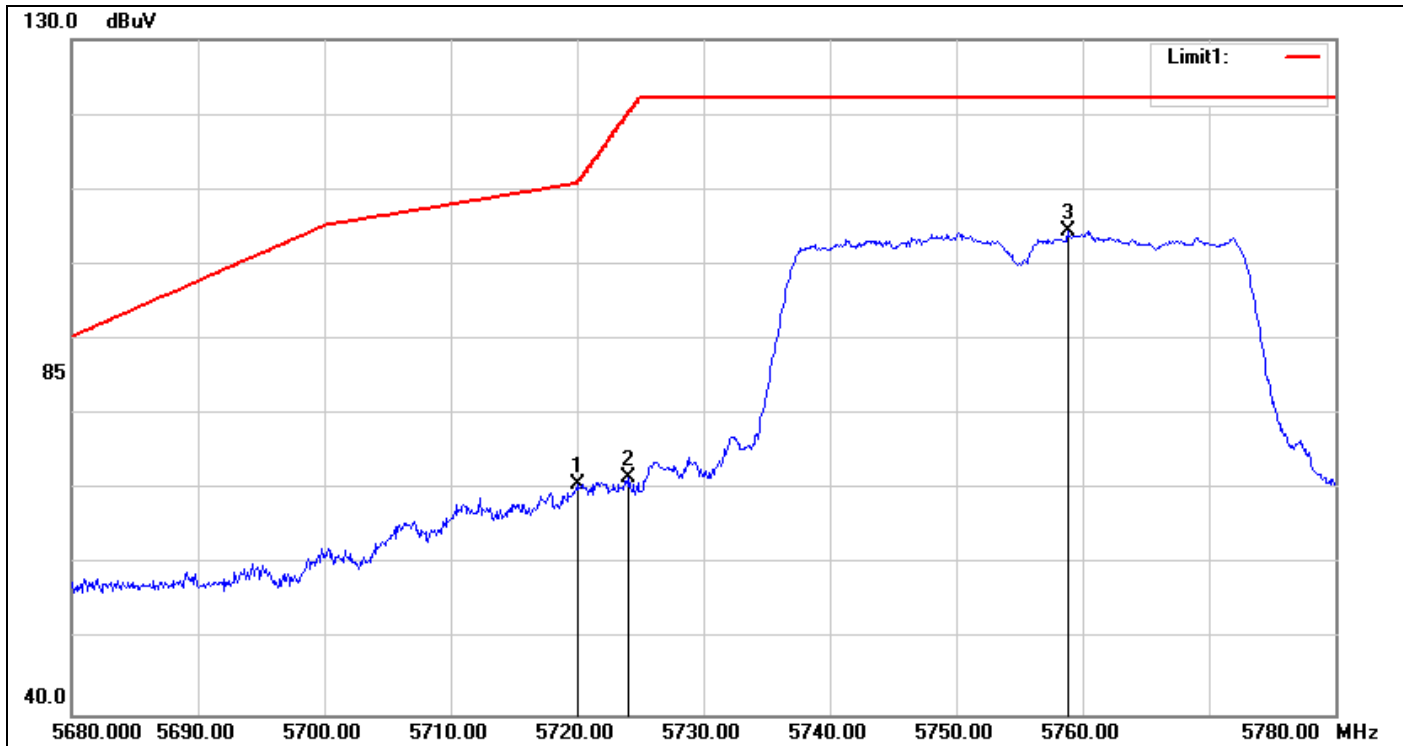

No.	Frequency (MHz)	Reading (dBuV)	Correct Factor (dB)	Result (dBuV)	Limit (dBuV)	Margin (dB)	Remark
1	5720.100	64.48	6.19	70.67	111.03	-40.36	peak
2	5724.100	65.48	6.20	71.68	120.15	-48.47	peak
3	5758.800	98.15	6.35	104.50	-	-	peak

Detector mode: Average

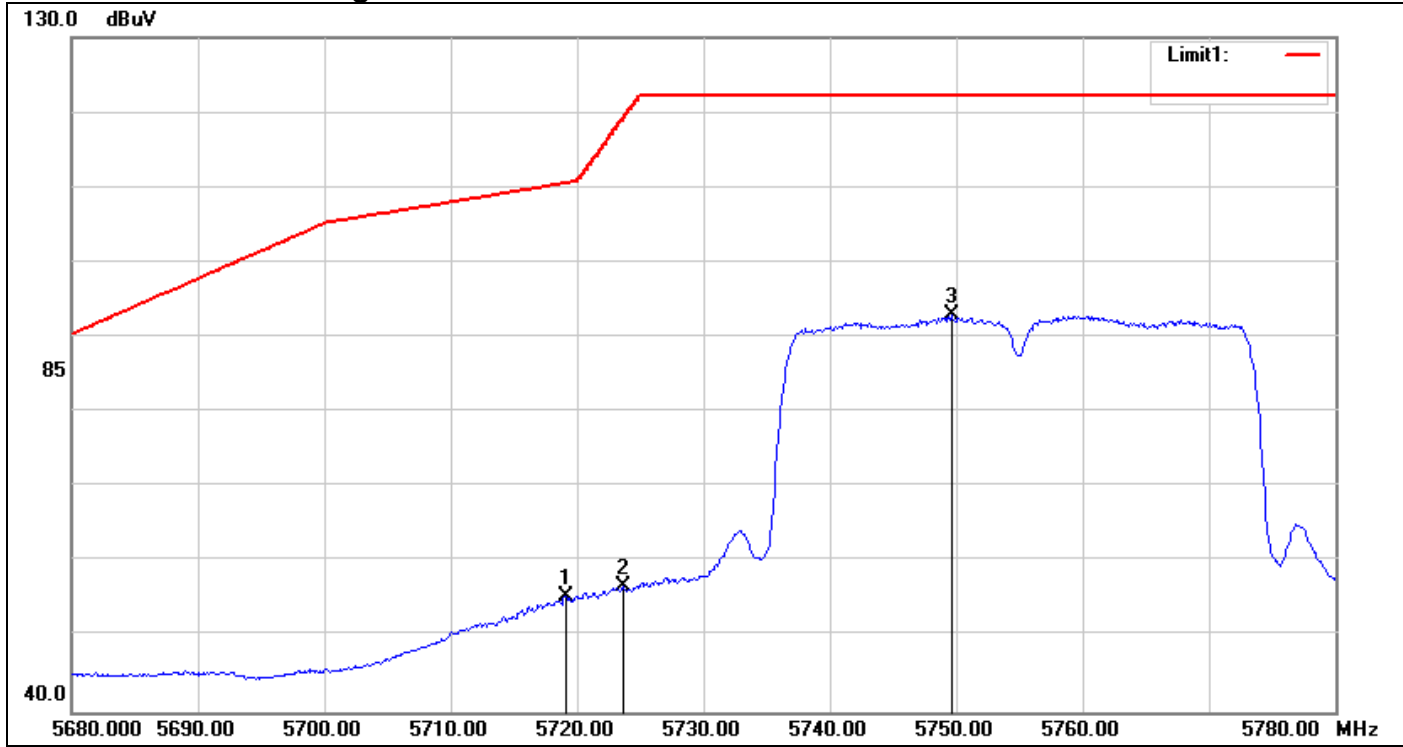

No.	Frequency (MHz)	Reading (dBuV)	Correct Factor(dB)	Result (dBuV)	Limit (dBuV)	Margin (dB)	Remark
1	5719.100	49.29	6.18	55.47	110.55	-55.08	AVG
2	5723.600	50.57	6.20	56.77	119.01	-62.24	AVG
3	5749.600	86.62	6.31	92.93	-	-	AVG

Band Edges (IEEE 802.11n HT 40 MHz mode / CH High)

Detector mode: Peak

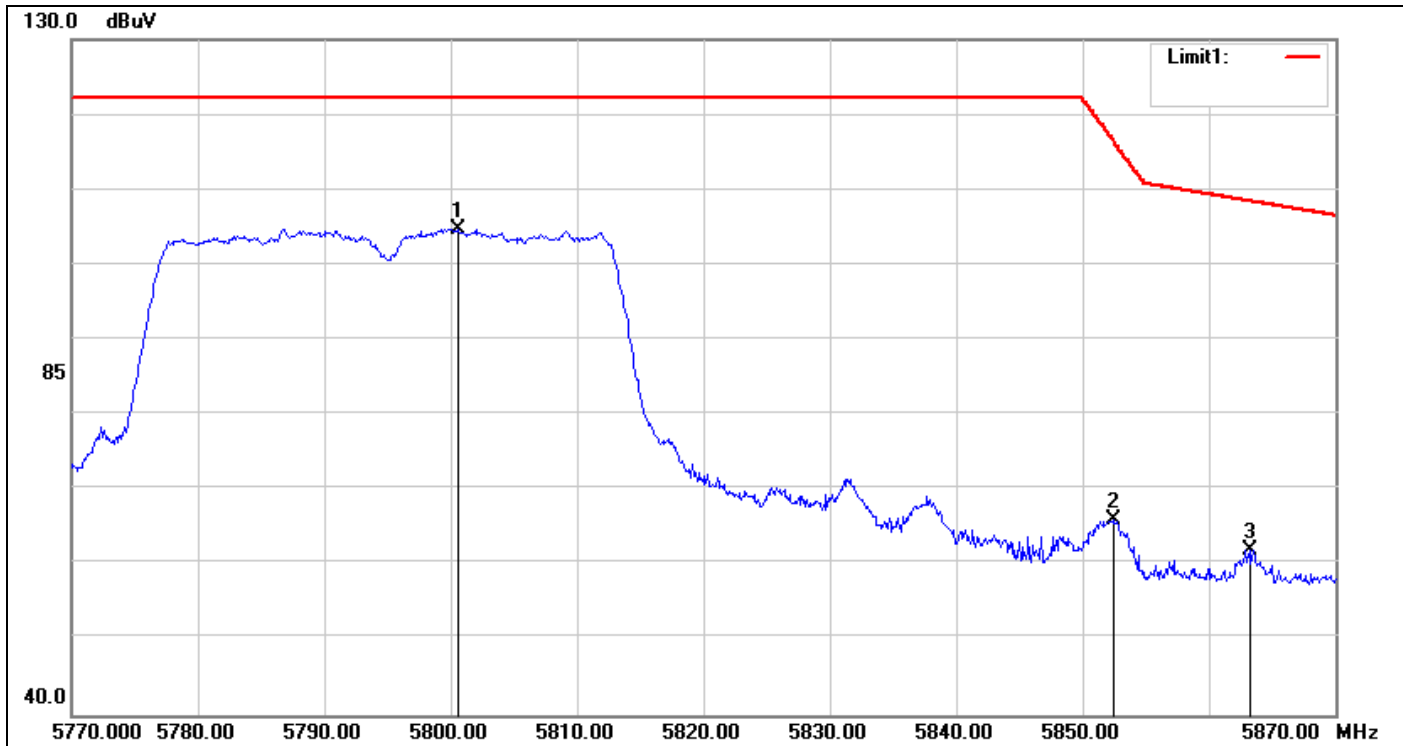

No.	Frequency (MHz)	Reading (dBuV)	Correct Factor(dB)	Result (dBuV)	Limit (dBuV)	Margin (dB)	Remark
1	5800.600	98.19	6.53	104.72	-	-	peak
2	5852.400	59.34	6.75	66.09	116.73	-50.64	peak
3	5863.200	55.16	6.80	61.96	108.50	-46.54	peak

Detector mode: Average

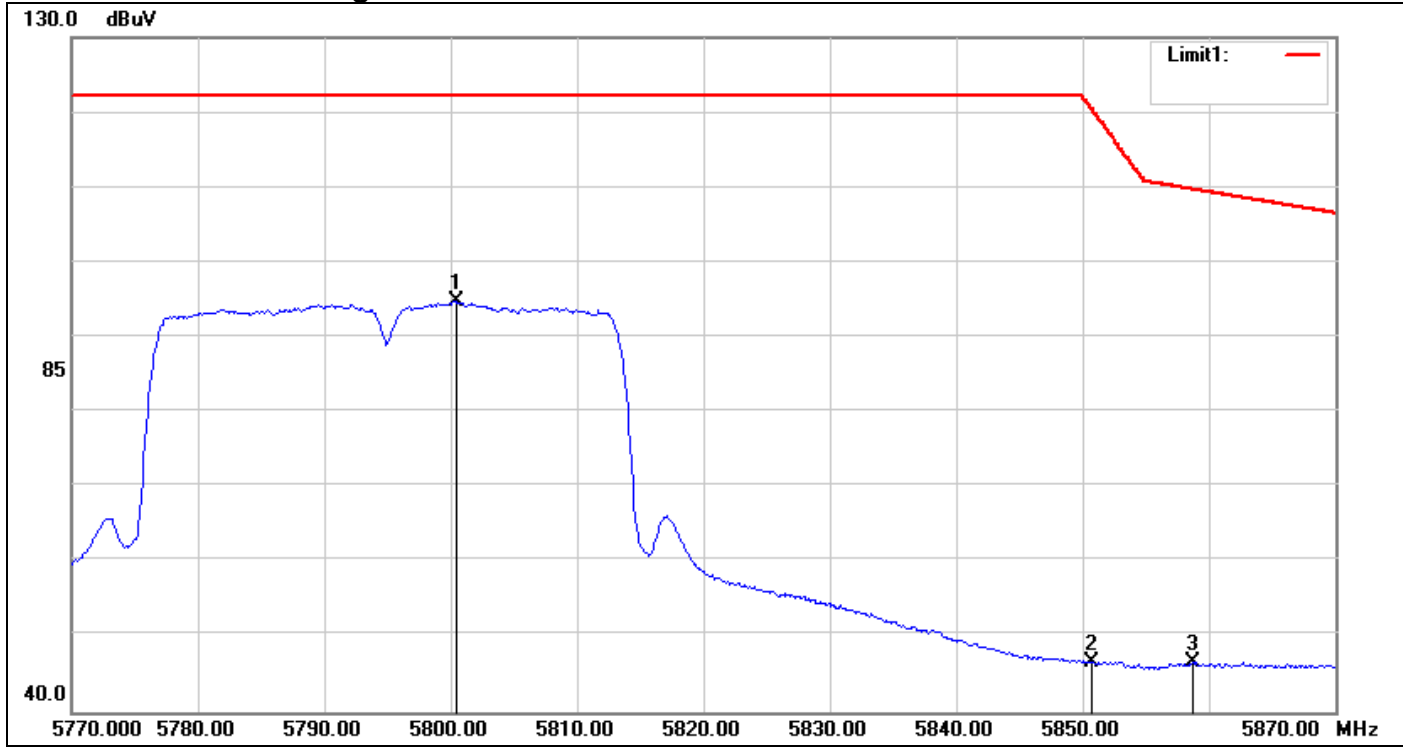

No.	Frequency (MHz)	Reading (dBuV)	Correct Factor(dB)	Result (dBuV)	Limit (dBuV)	Margin (dB)	Remark
1	5800.400	88.17	6.53	94.70	-	-	AVG
2	5850.700	40.01	6.74	46.75	120.60	-73.85	AVG
3	5858.700	39.82	6.78	46.60	109.76	-63.16	AVG

7.4 PEAK POWER SPECTRAL DENSITY

LIMIT

1. According to §15.407, for digitally modulated systems, the power spectral density conducted from the intentional radiator to the antenna shall not be greater than 30 dBm in any 500 kHz band during any time interval of continuous transmission.

Test Configuration

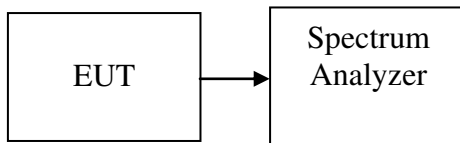

TEST PROCEDURE

1. Place the EUT on the table and set it in transmitting mode. Remove the antenna from the EUT and then connect a low loss RF cable from the antenna port to the spectrum analyzer.
2. Set the spectrum analyzer as RBW = 500kHz, VBW = 3 x RBW, Span = 1.5 x bandwidth, Sweep=auto
3. Record the max reading.
4. Repeat the above procedure until the measurements for all frequencies are completed.

TEST RESULTS

No non-compliance noted

Test Data

Test mode: IEEE 802.11a mode/ 5745 ~ 5825MHz

Channel	Frequency (MHz)	PPSD (dBm)	Limit (dBm)	Result
Low	5745	6.88	27.68	PASS
Mid	5785	7.33		PASS
High	5825	7.57		PASS

Test mode: IEEE 802.11n HT 20 MHz mode / 5745 ~ 5825MHz

Channel	Frequency (MHz)	Chain 0 PPSD (dBm)	Chain 1 PPSD (dBm)	PPSD (dBm)	Limit (dBm)	Result
Low	5745	7.85	5.25	9.75	27.68	PASS
Mid	5785	7.31	4.45	9.12		PASS
High	5825	7.68	5.28	9.65		PASS

Test mode: IEEE 802.11n HT 40 MHz mode / 5755 ~ 5795MHz

Channel	Frequency (MHz)	Chain 0 PPSD (dBm)	Chain 1 PPSD (dBm)	PPSD (dBm)	Limit (dBm)	Result
Low	5755	4.09	2.15	6.24	27.68	PASS
High	5795	3.93	1.80	6.00		PASS

Remark:

1. Total PPSD (dBm) = $10 \cdot \text{LOG}(10^{(\text{Chain 0 PPSD} / 10)} + 10^{(\text{Chain 1 PPSD} / 10)})$
2. The maximum antenna gain is 8.32dBi; therefore the reduction due to antenna gain is 2.32dBi, so the limit is 27.68dBm.

Test Plot

IEEE 802.11a MHz mode / 5745 ~ 5825MHz

PPSD (CH Low)

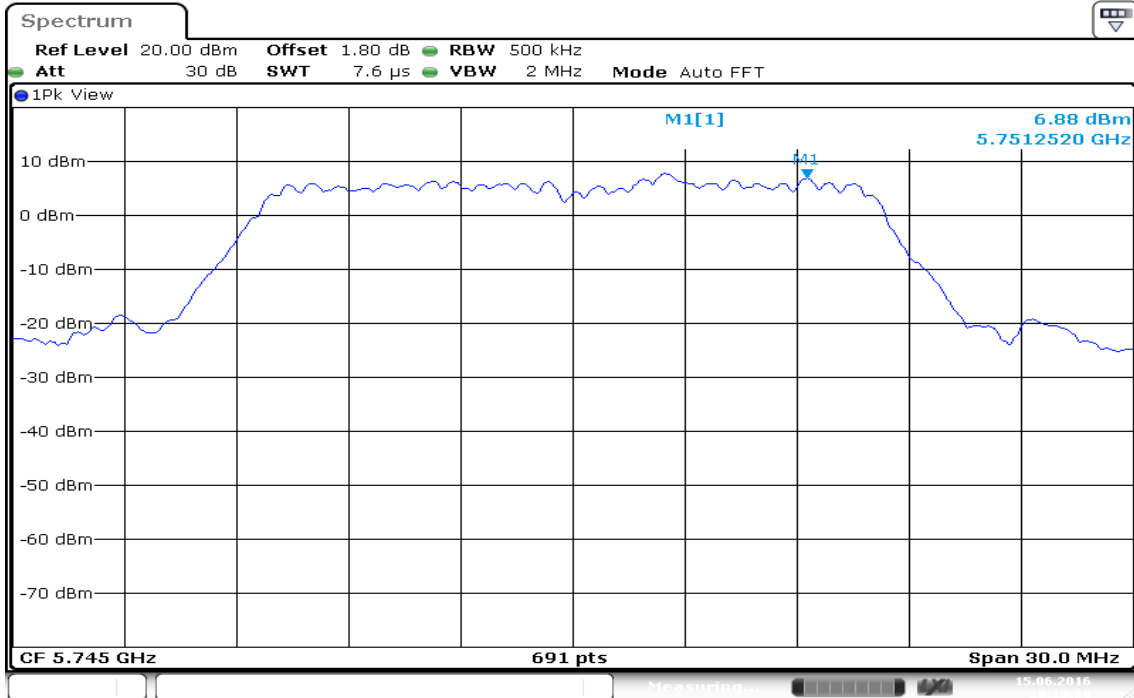

Date: 15.JUN.2016 20:18:29

PPSD (CH Mid)

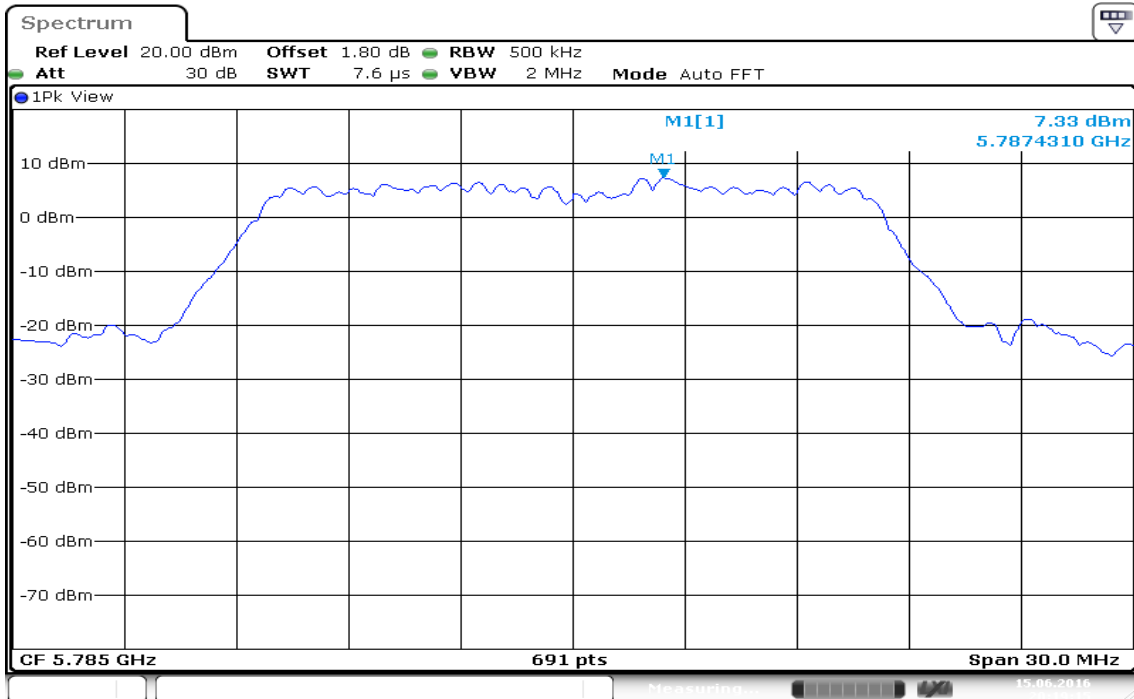

Date: 15.JUN.2016 20:19:15

PPSD (CH High)

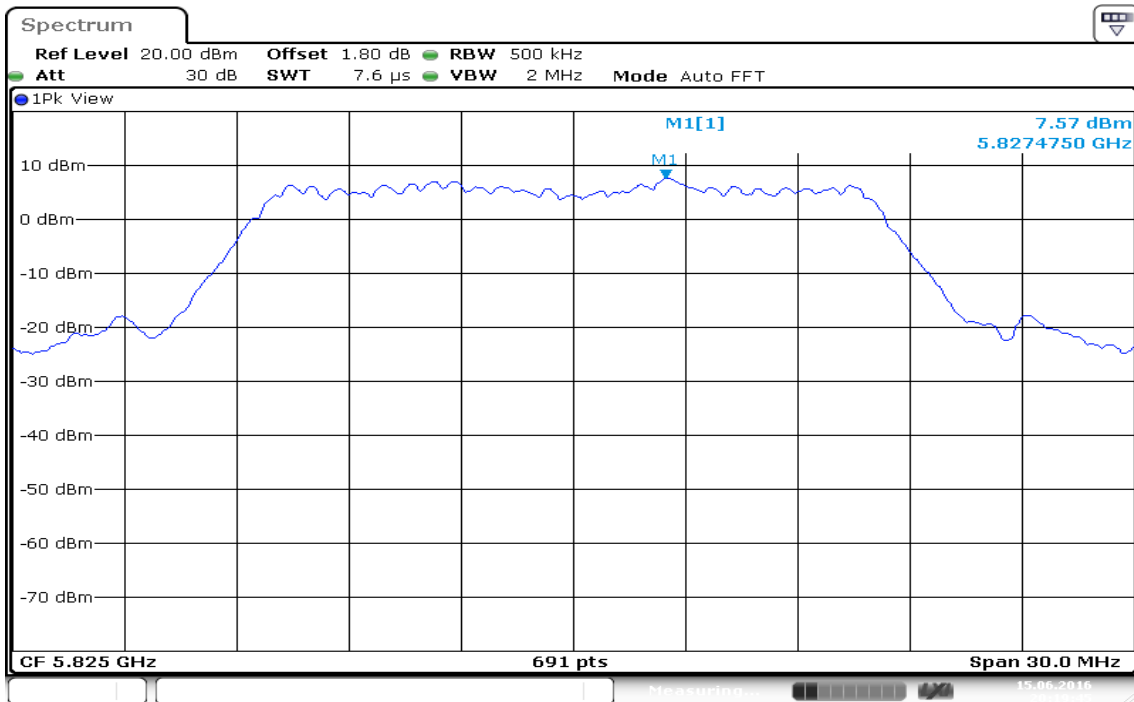

Date: 15.JUN.2016 20:19:45

IEEE 802.11n HT 20 MHz mode / 5745 ~ 5825MHz / Chain 0

PPSD (CH Low)

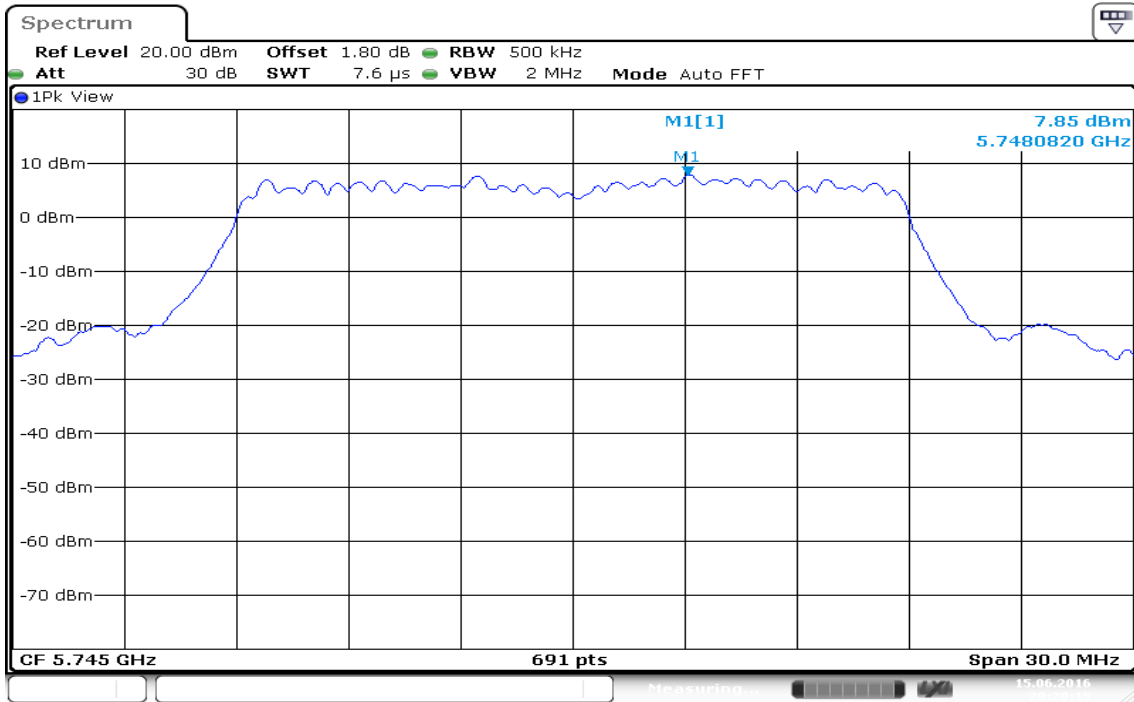

Date: 15.JUN.2016 20:20:15

PPSD (CH Mid)

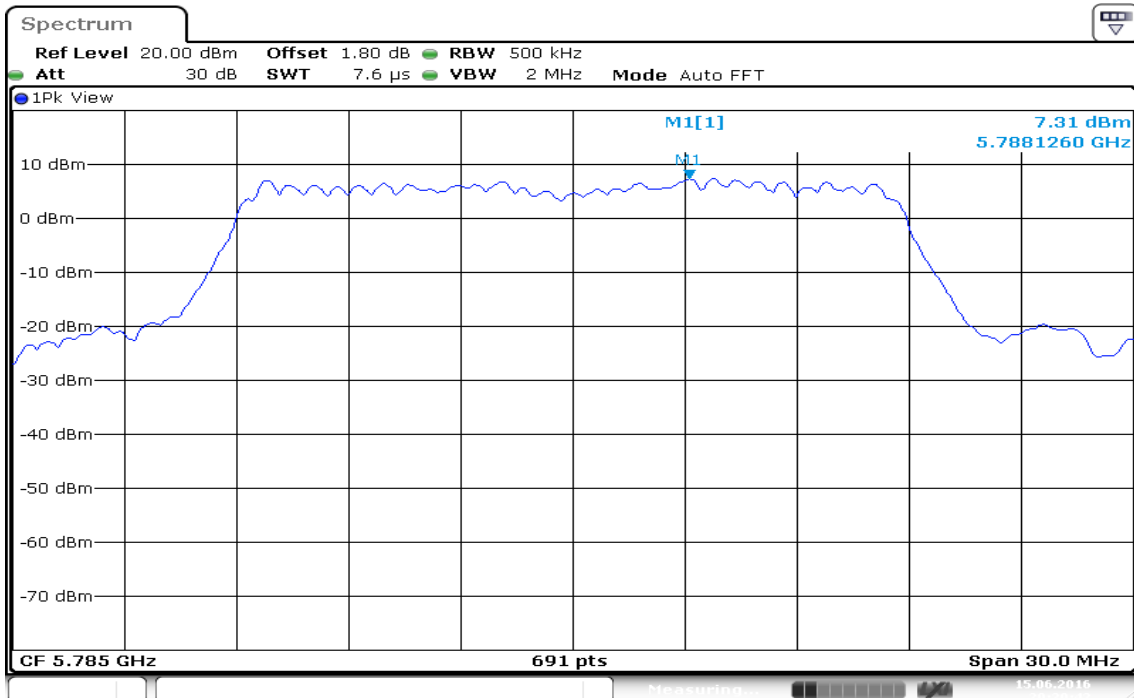

Date: 15.JUN.2016 20:20:42

PPSD (CH High)

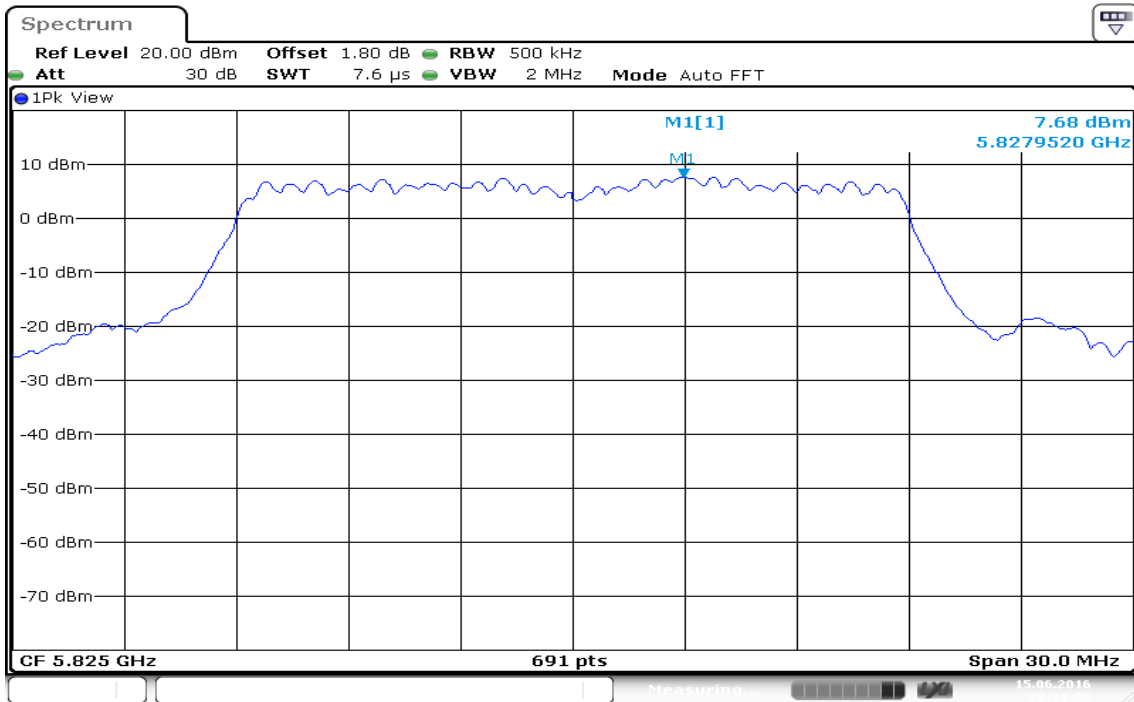

Date: 15.JUN.2016 20:21:07

IEEE 802.11n HT 20 MHz mode / 5745 ~ 5825MHz / Chain 1
PPSD (CH Low)

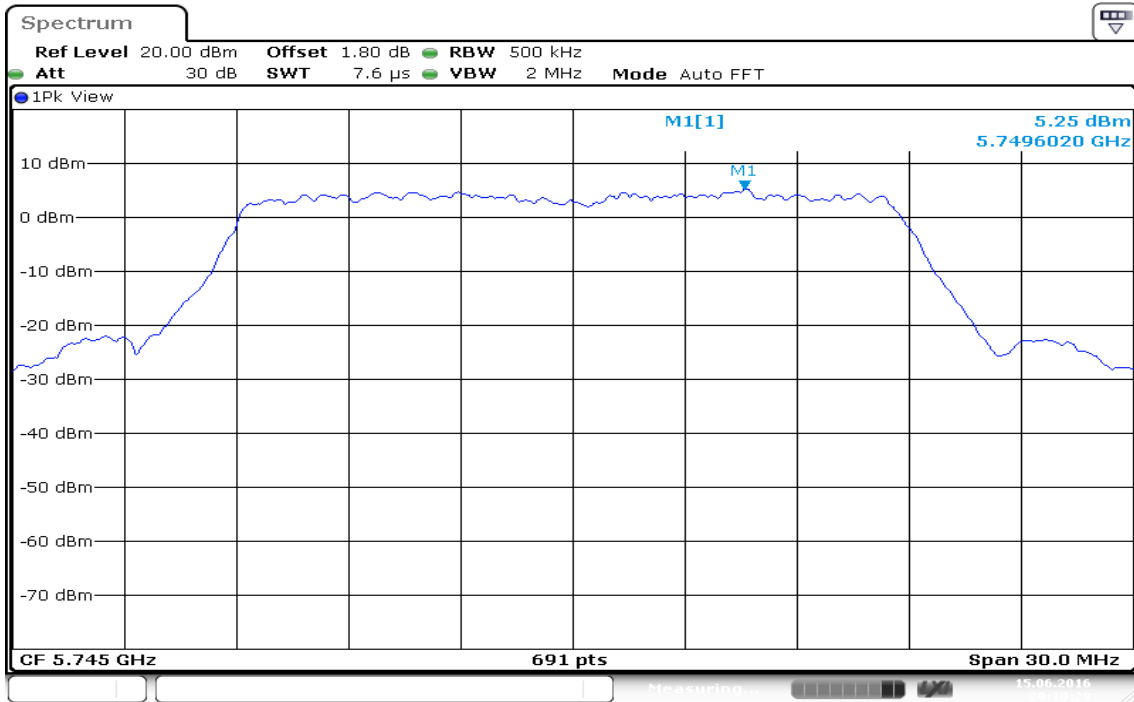

Date: 15.JUN.2016 20:10:29

PPSD (CH Mid)

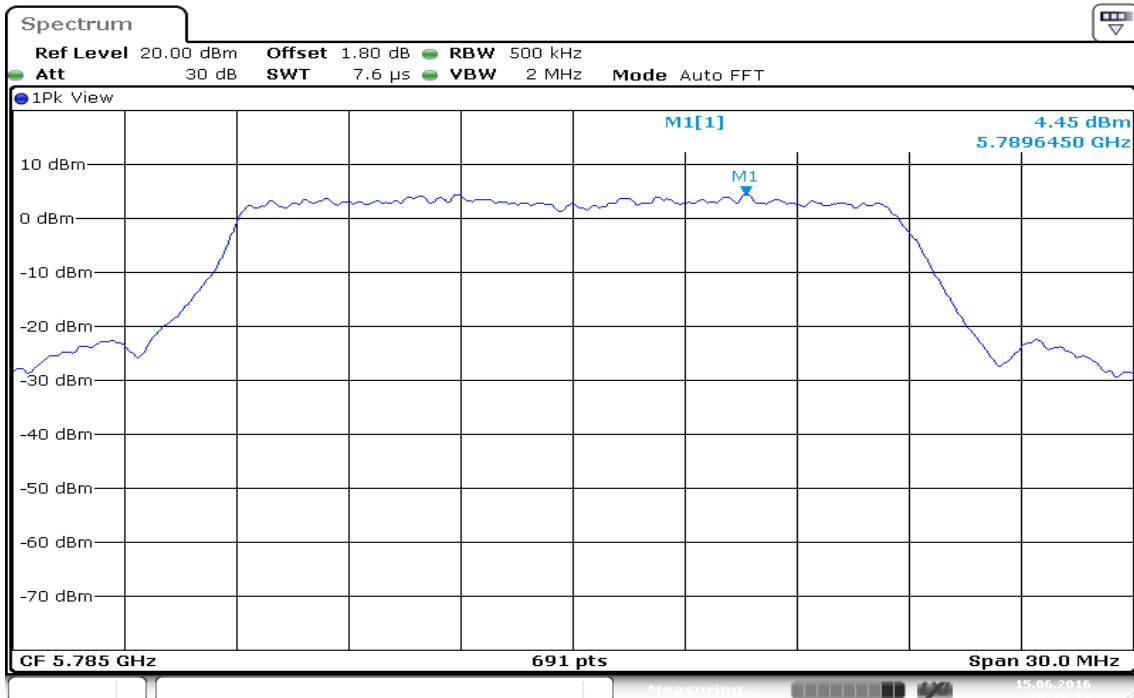

Date: 15.JUN.2016 20:16:11

PPSD (CH High)

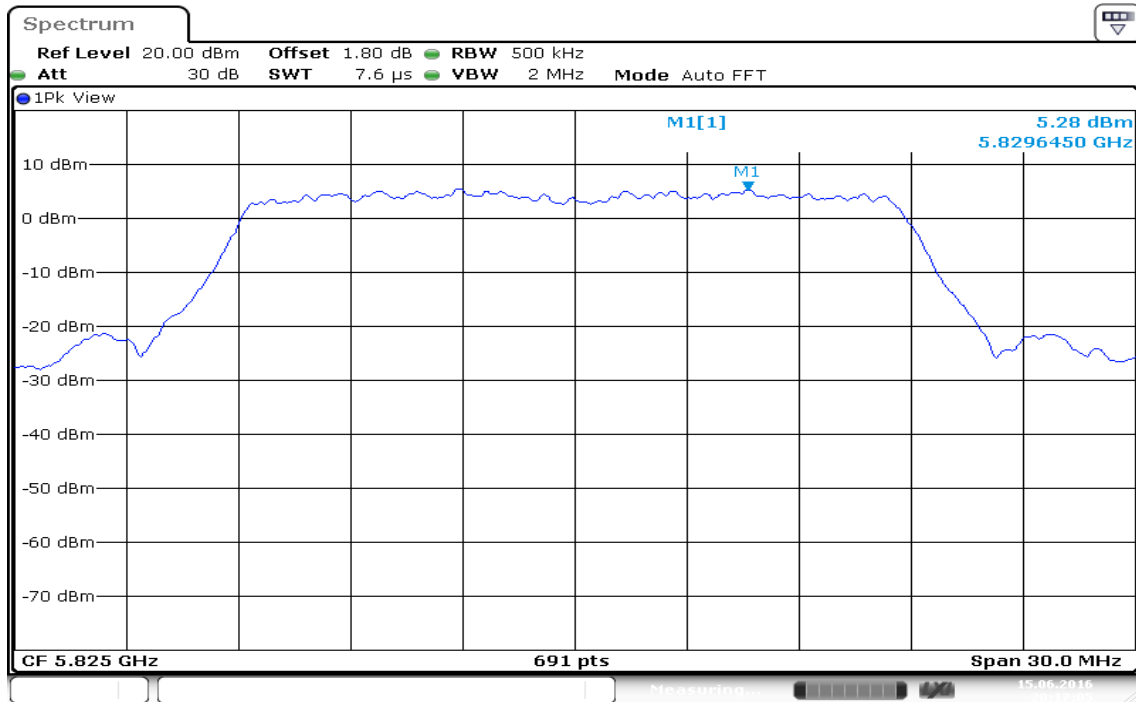

Date: 15.JUN.2016 20:17:05

IEEE 802.11n HT 40 MHz mode / 5755 ~ 5795MHz / Chain 0
PPSD (CH Low)

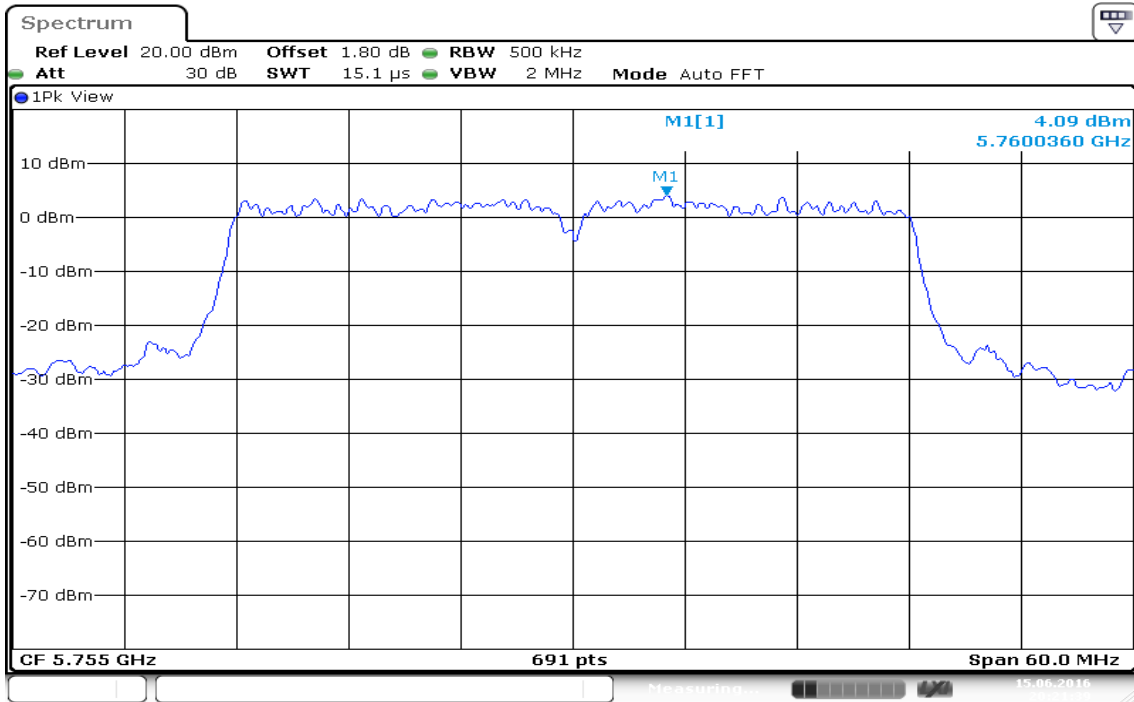

PPSD (CH High)

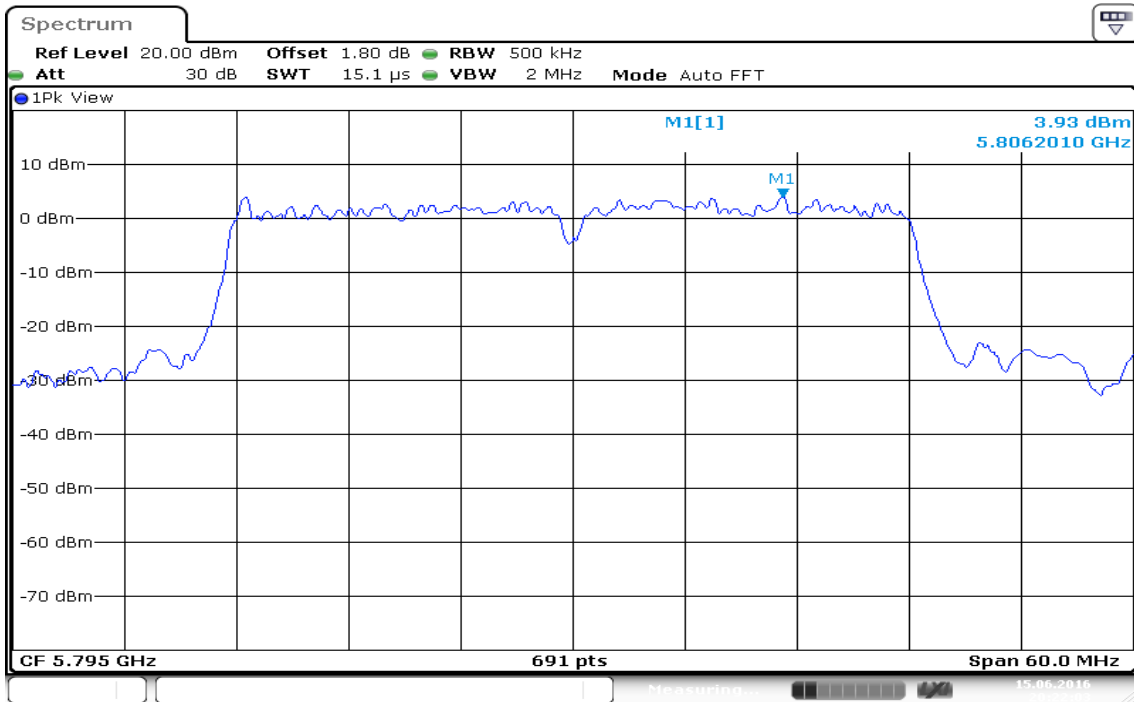

IEEE 802.11n HT 40 MHz mode / 5755 ~ 5795MHz / Chain 1 PPSD (CH Low)

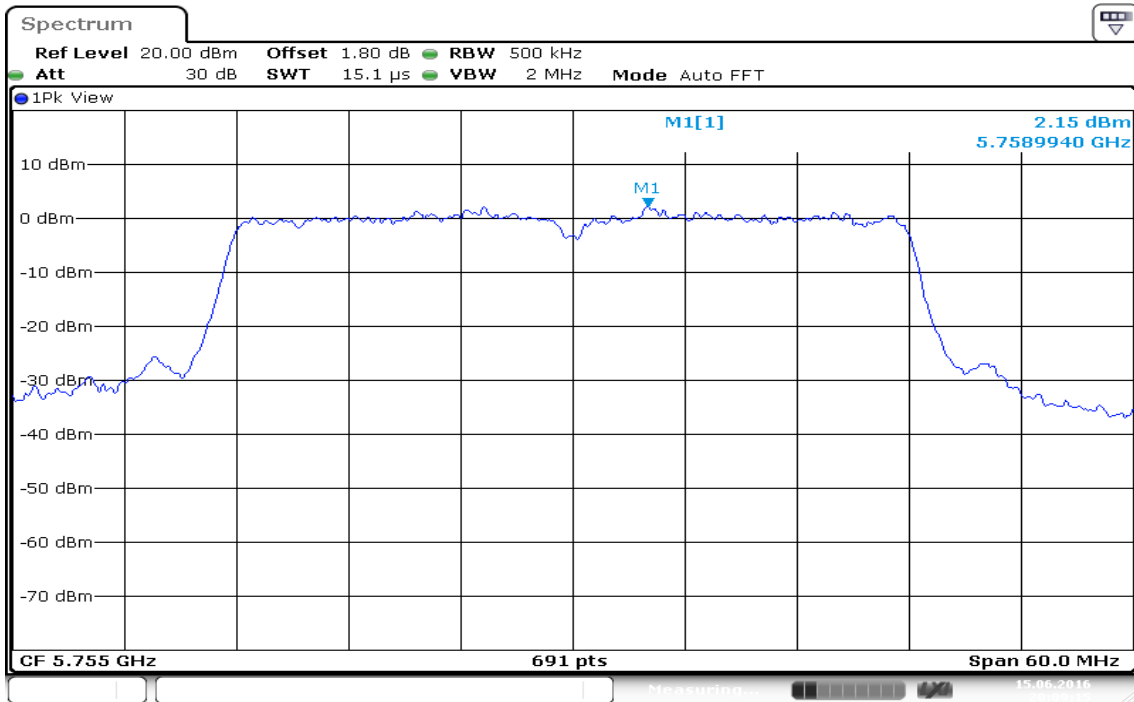

Date: 15.JUN.2016 20:09:15

PPSD (CH High)

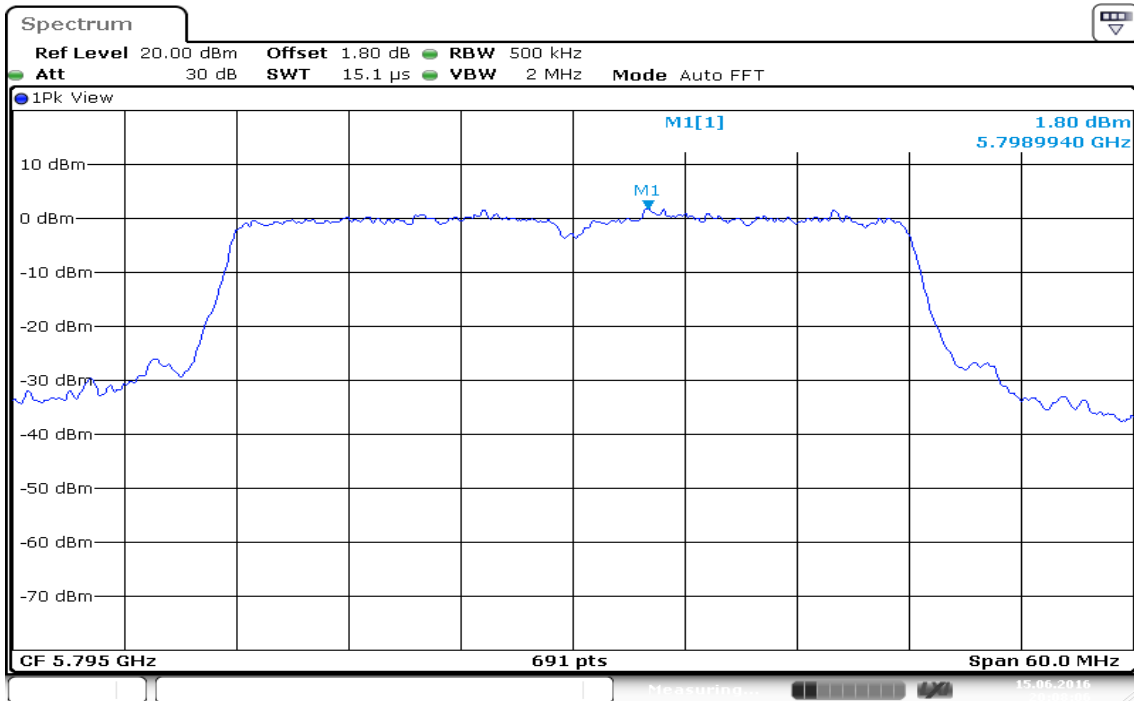

Date: 15.JUN.2016 20:08:06

7.5 RADIATED EMISSIONS

LIMIT

1. According to §15.209(a), except as provided elsewhere in this Subpart, the emissions from an intentional radiator shall not exceed the field strength levels specified in the following table:

Frequency (MHz)	Field Strength (µV/m)	Measurement Distance (m)
0.009 - 0.490	2400/F(kHz)	300
0.490 - 1.705	24000/F(kHz)	30
1.705 – 30.0	30	30
30-88	100	3
88-216	150	3
216-960	200	3
Above 960	500	3

Remark: Except as provided in paragraph (g), fundamental emissions from intentional radiators operating under this Section shall not be located in the frequency bands 54-72 MHz, 76-88 MHz, 174-216 MHz or 470-806 MHz. However, operation within these frequency bands is permitted under other sections of this Part, e.g., Sections 15.231 and 15.241.

2. In the emission table above, the tighter limit applies at the band edges.

Frequency (MHz)	Field Strength (µV/m at 3-meter)	Field Strength (dBµV/m at 3-meter)
0.009 - 0.490	2400/F(kHz) +80	20LOG((2400/F(kHz))+80)
0.490 - 1.705	24000/F(kHz) +40	20LOG((24000/F(kHz))+40)
1.705 – 30.0	30	69.54
30-88	100	40
88-216	150	43.5
216-960	200	46
Above 960	500	54

Test Configuration

9kHz ~ 30MHz

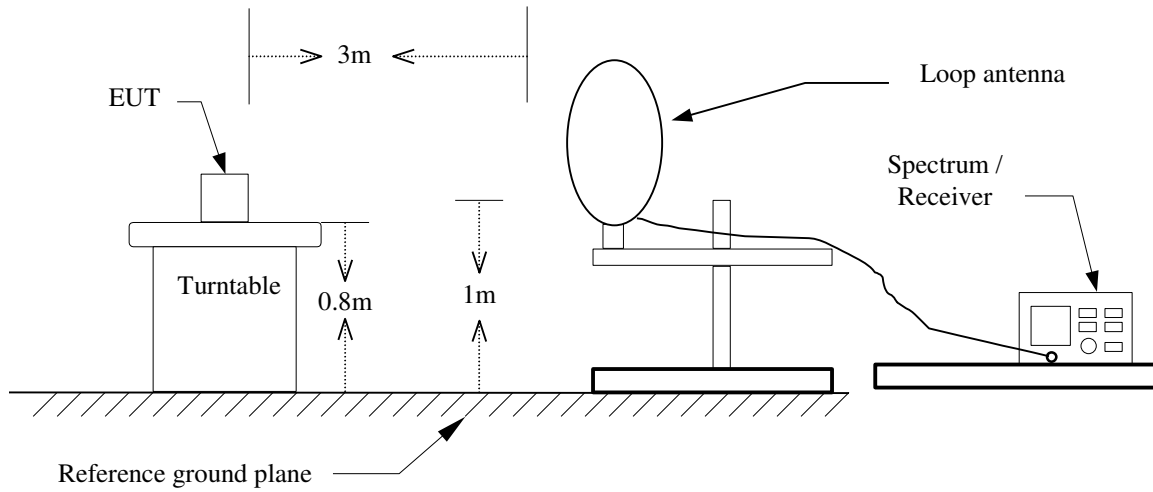

30MHz ~ 1GHz

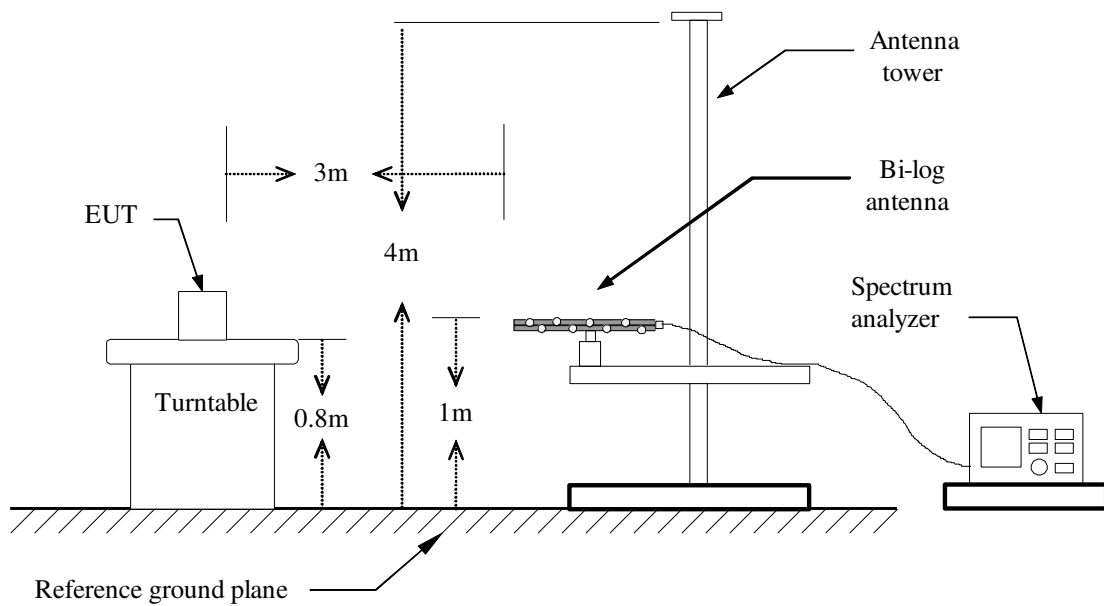

Above 1 GHz

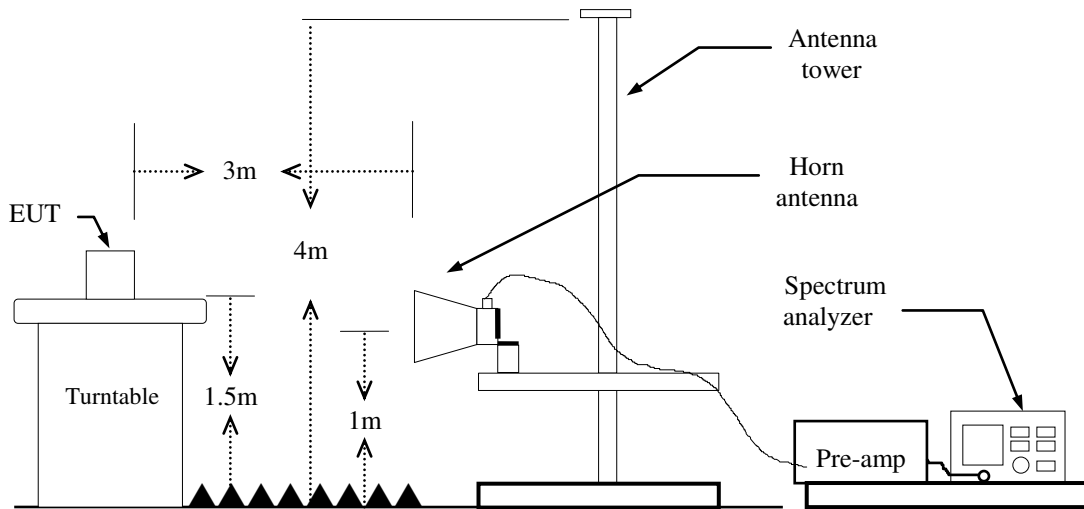

TEST PROCEDURE

1. The EUT is placed on a turntable, Above 1 GHz is 1.5m high and below 1 GHz is 0.8m high above ground plane.
2. The turntable shall be rotated for 360 degrees to determine the position of maximum emission level.
3. EUT is set 3m away from the receiving antenna, which is varied from 1m to 4m to find out the highest emissions.
4. Maximum procedure was performed on the six highest emissions to ensure EUT compliance.
5. And also, each emission was to be maximized by changing the polarization of receiving antenna both horizontal and vertical.
6. Set the spectrum analyzer in the following setting as:

Below 1GHz:

RBW=100kHz / VBW=300kHz / Sweep=AUTO

Above 1GHz:

(a) PEAK: RBW=VBW=1MHz / Sweep=AUTO

(b) AVERAGE: RBW=1MHz,
if duty cycle $\geq 98\%$, VBW=10Hz.
if duty cycle $< 98\%$ VBW=1/T.

IEEE 802.11a mode: $\geq 94\%$, VBW=750Hz

IEEE 802.11n HT 20 MHz mode: $\geq 94\%$, VBW=750Hz

IEEE 802.11n HT 40 MHz mode: $\geq 87\%$, VBW=1.5kHz

7. Repeat above procedures until the measurements for all frequencies are complete.
8. Result = Spectrum Reading + cable loss(spectrum to Amp) - Amp Gain + Cable loss(Amp to receive Ant)+ Receive Ant

Below 1 GHz

Operation Mode: Normal Link

Test Date: June 15, 2016

Temperature: 27°C

Tested by: Dennis Li

Humidity: 53% RH

Polarity: Ver.

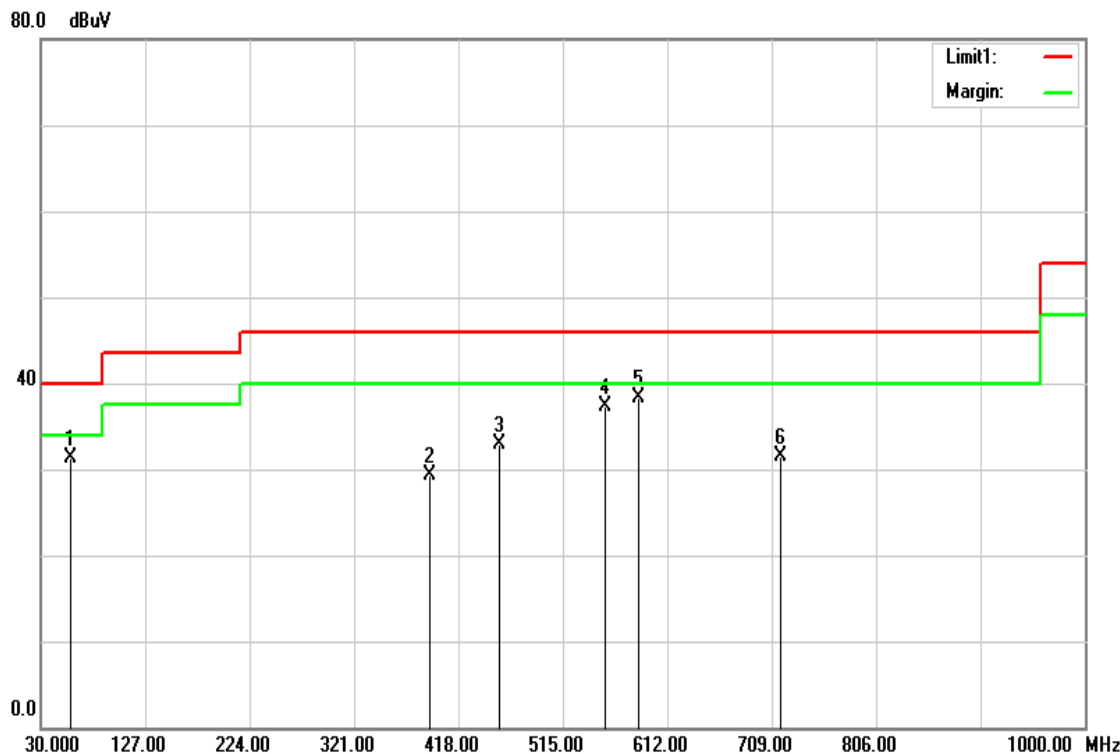

Frequency (MHz)	Reading (dBuV)	Correction Factor (dB/m)	Result (dBuV/m)	Limit (dBuV/m)	Margin (dB)	Remark	Ant.Pol. (H/V)
57.1600	53.16	-21.81	31.35	40.00	-8.65	peak	V
390.8400	41.25	-11.92	29.33	46.00	-16.67	peak	V
455.8300	42.99	-10.08	32.91	46.00	-13.09	peak	V
553.8000	45.76	-8.43	37.33	46.00	-8.67	peak	V
585.8100	46.34	-7.97	38.37	46.00	-7.63	peak	V
716.7600	37.09	-5.68	31.41	46.00	-14.59	peak	V

Remark:

1. No emission found between lowest internal used/generated frequency to 30MHz (9kHz~30MHz).
2. Radiated emissions measured in frequency range from 30 MHz to 1000MHz were made with an instrument using peak/quasi-peak detector mode.
3. Quasi-peak test would be performed if the peak result were greater than the quasi-peak limit or as required by the applicant.
4. Measurements above show only up to 6 maximum emissions noted, or would be lesser, with " N/A " remark, if no specific emissions from the EUT are recorded (ie: margin>20dB from the applicable limit) and considered that's already beyond the background noise floor.
5. Margin (dB) = Remark result (dBuV/m) – Quasi-peak limit (dBuV/m).

Operation Mode: Normal Link

Test Date: June 15, 2016

Temperature: 27°C

Tested by: Dennis Li

Humidity: 53% RH

Polarity: Hor.

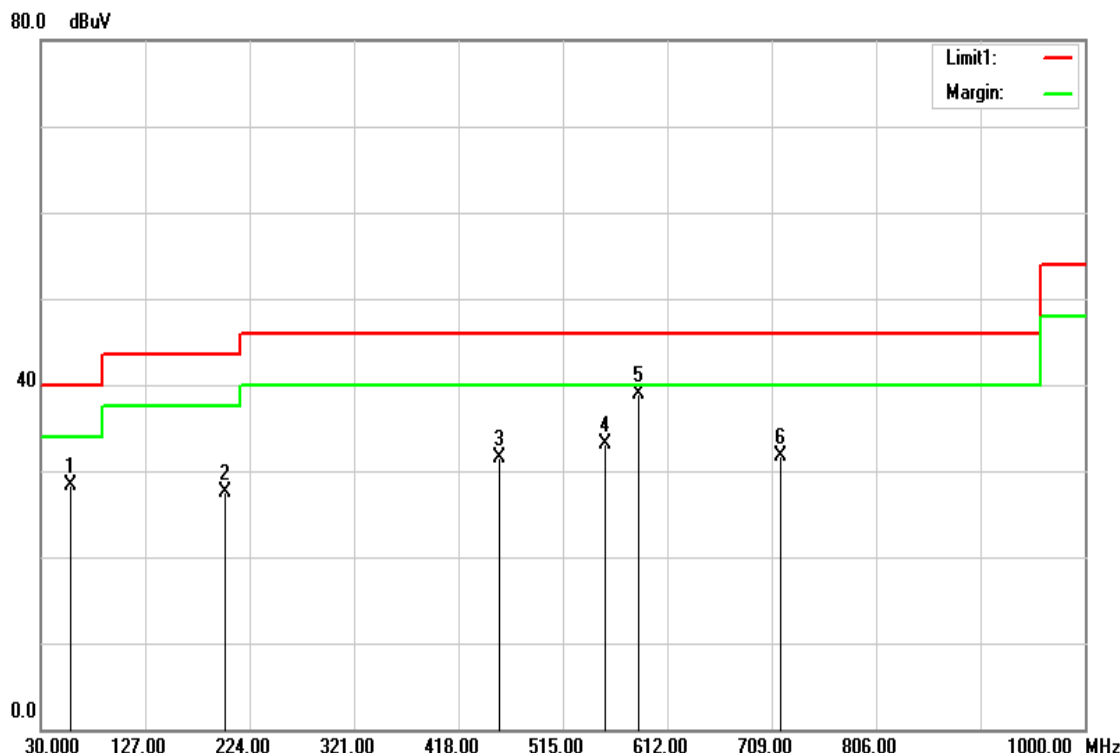

Frequency (MHz)	Reading (dBuV)	Correction Factor (dB/m)	Result (dBuV/m)	Limit (dBuV/m)	Margin (dB)	Remark	Ant.Pol. (H/V)
57.1600	50.20	-21.81	28.39	40.00	-11.61	peak	H
200.7200	43.19	-15.60	27.59	43.50	-15.91	peak	H
455.8300	41.63	-10.08	31.55	46.00	-14.45	peak	H
553.8000	41.47	-8.43	33.04	46.00	-12.96	peak	H
585.8100	46.89	-7.97	38.92	46.00	-7.08	peak	H
716.7600	37.37	-5.68	31.69	46.00	-14.31	peak	H

Remark:

1. No emission found between lowest internal used/generated frequency to 30MHz (9kHz~30MHz).
2. Radiated emissions measured in frequency range from 30 MHz to 1000MHz were made with an instrument using peak/quasi-peak detector mode.
3. Quasi-peak test would be performed if the peak result were greater than the quasi-peak limit or as required by the applicant.
4. Measurements above show only up to 6 maximum emissions noted, or would be lesser, with " N/A " remark, if no specific emissions from the EUT are recorded (ie: margin>20dB from the applicable limit) and considered that's already beyond the background noise floor.
5. Margin (dB) = Remark result (dBuV/m) – Quasi-peak limit (dBuV/m).

Above 1 GHz

TX / IEEE 802.11a mode / CH Low

Polarity: Vertical

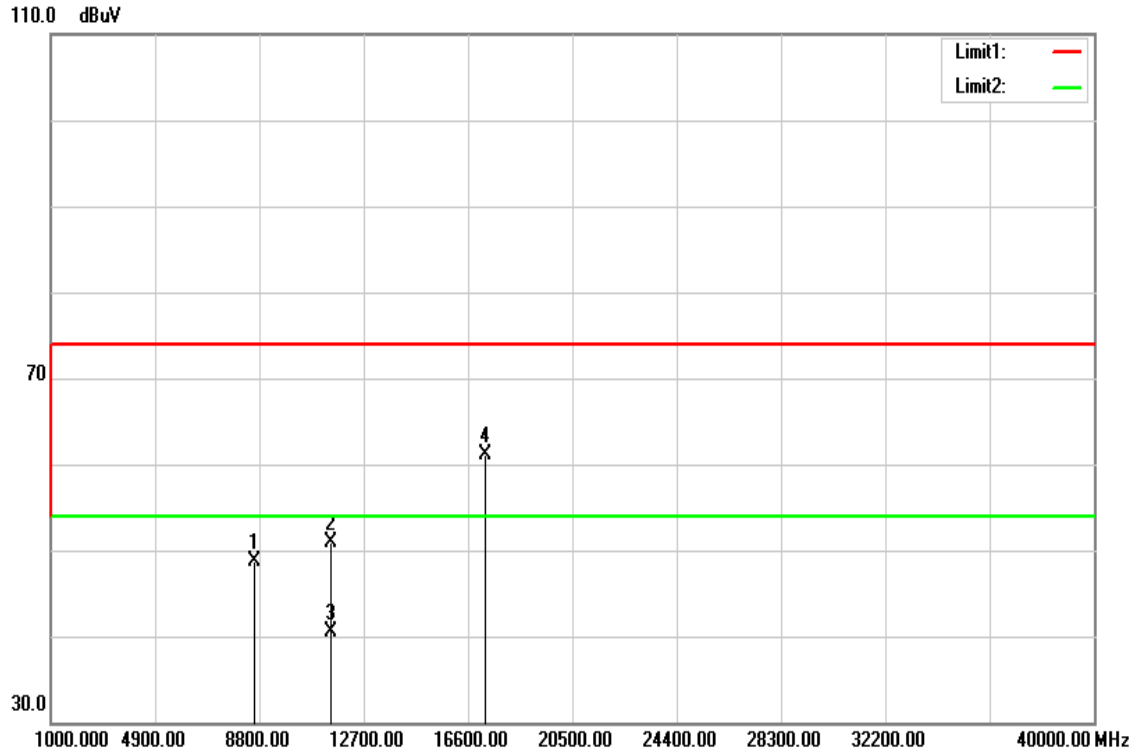

Polarity: Horizontal

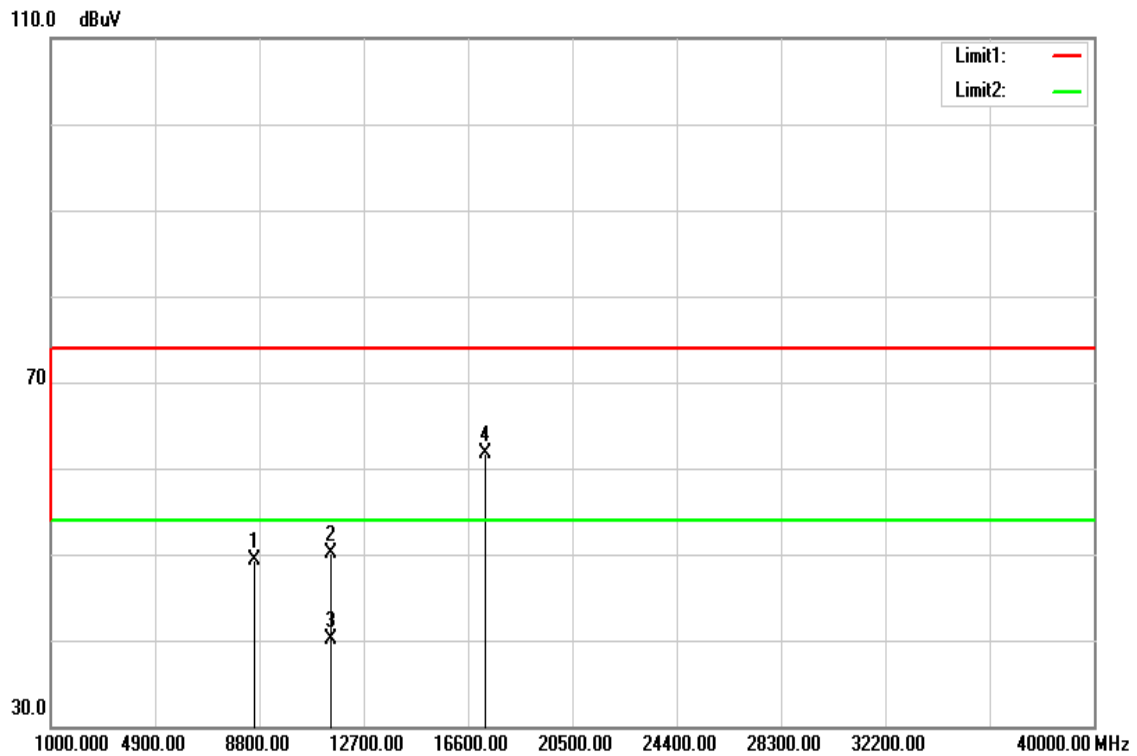

Operation Mode: TX / IEEE 802.11a mode / CH Low **Test Date:** June 15, 2016
Temperature: 27°C **Tested by:** Dennis Li
Humidity: 53% RH **Polarity:** Ver. / Hor.

Frequency (MHz)	Reading (dBuV)	Correction (dB/m)	Result (dBuV/m)	Limit (dBuV/m)	Margin (dB)	Remark	Ant.Pol. (H/V)
8639.000	34.91	13.70	48.61	74.00	-25.39	peak	V
11490.000	34.11	16.78	50.89	74.00	-23.11	peak	V
11490.000	23.69	16.78	40.47	54.00	-13.53	AVG	V
17235.000	35.88	25.28	61.16	74.00	-12.84	peak	V
N/A							
8639.000	35.69	13.70	49.39	74.00	-24.61	peak	H
11490.000	33.33	16.78	50.11	74.00	-23.89	peak	H
11490.000	23.34	16.78	40.12	54.00	-13.88	AVG	H
17235.000	36.46	25.28	61.74	74.00	-12.26	peak	H
N/A							

Remark:

1. Measuring frequencies from 1 GHz to the 10th harmonic of highest fundamental frequency.
2. Radiated emissions measured in frequency above 1000MHz were made with an instrument using peak/average detector mode.
3. Average test would be performed if the peak result were greater than the average limit.
4. Data of measurement within this frequency range shown " --- " in the table above means the reading of emissions are attenuated more than 20dB below the permissible limits or the field strength is too small to be measured.
5. Measurements above show only up to 6 maximum emissions noted, or would be lesser, with " N/A " remark, if no specific emissions from the EUT are recorded (ie: margin>20dB from the applicable limit) and considered that's already beyond the background noise floor.
6. Margin (dB) = Remark result (dBuV/m) – Average limit (dBuV/m).

TX / IEEE 802.11a mode / CH Mid

Polarity: Vertical

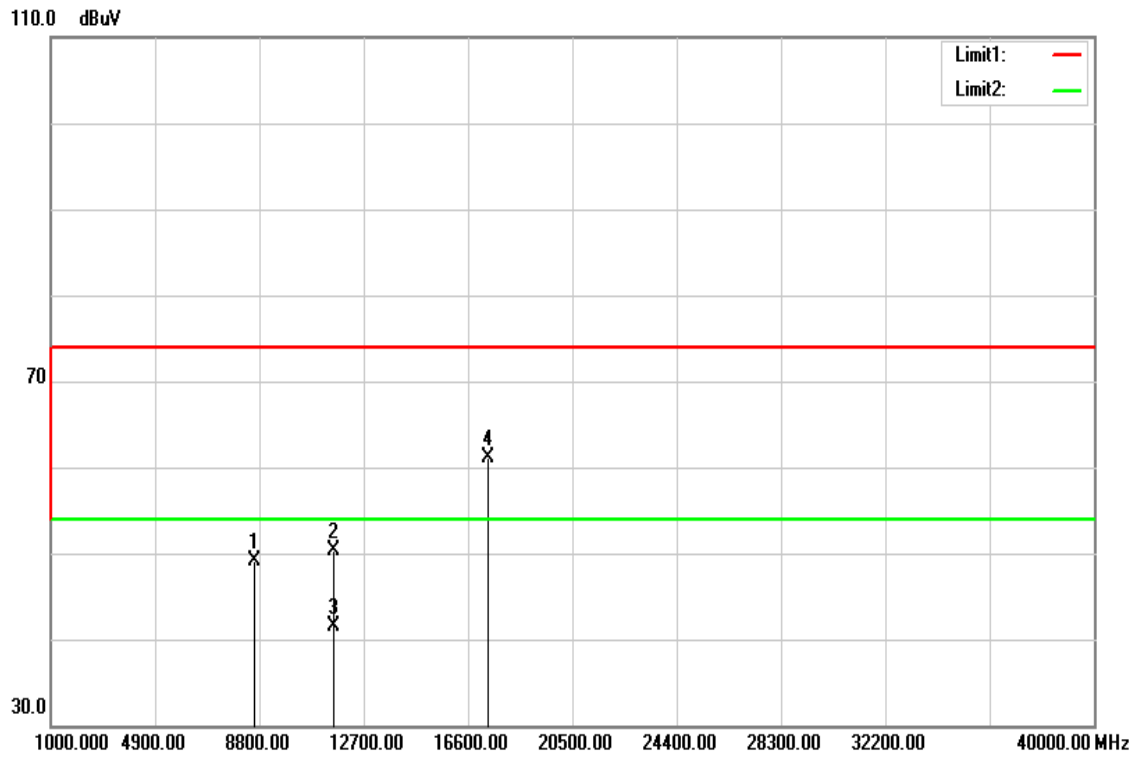

Polarity: Horizontal

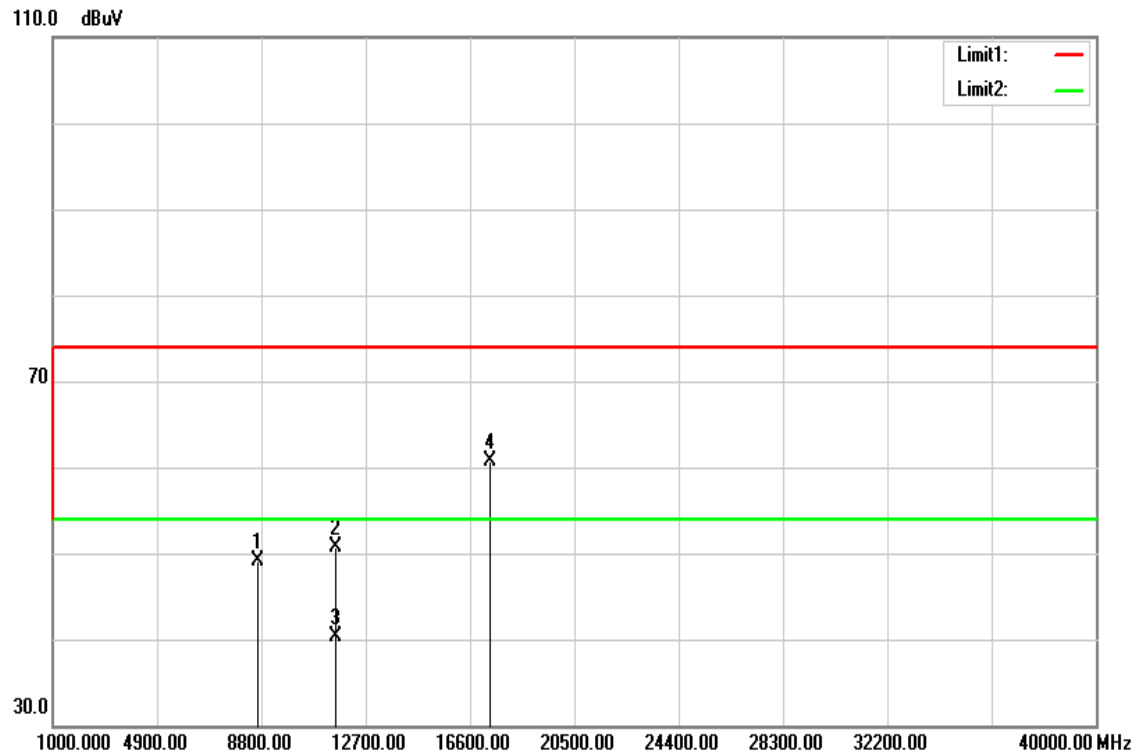

Operation Mode: TX / IEEE 802.11a mode / CH Mid **Test Date:** June 15, 2016
Temperature: 27°C **Tested by:** Dennis Li
Humidity: 53% RH **Polarity:** Ver. / Hor.

Frequency (MHz)	Reading (dBuV)	Correction (dB/m)	Result (dBuV/m)	Limit (dBuV/m)	Margin (dB)	Remark	Ant.Pol. (H/V)
8613.000	35.45	13.69	49.14	74.00	-24.86	peak	V
11570.000	33.51	16.84	50.35	74.00	-23.65	peak	V
11570.000	24.72	16.84	41.56	54.00	-12.44	AVG	V
17355.000	35.40	25.75	61.15	74.00	-12.85	peak	V
N/A							
8656.000	35.46	13.71	49.17	74.00	-24.83	peak	H
11570.000	33.87	16.84	50.71	74.00	-23.29	peak	H
11570.000	23.52	16.84	40.36	54.00	-13.64	AVG	H
17355.000	34.92	25.75	60.67	74.00	-13.33	peak	H
N/A							

Remark:

1. Measuring frequencies from 1 GHz to the 10th harmonic of highest fundamental frequency.
2. Radiated emissions measured in frequency above 1000MHz were made with an instrument using peak/average detector mode.
3. Average test would be performed if the peak result were greater than the average limit.
4. Data of measurement within this frequency range shown “ --- ” in the table above means the reading of emissions are attenuated more than 20dB below the permissible limits or the field strength is too small to be measured.
5. Measurements above show only up to 6 maximum emissions noted, or would be lesser, with “ N/A ” remark, if no specific emissions from the EUT are recorded (ie: margin>20dB from the applicable limit) and considered that's already beyond the background noise floor.
6. Margin (dB) = Remark result (dBuV/m) – Average limit (dBuV/m).

TX / IEEE 802.11a mode / CH High

Polarity: Vertical

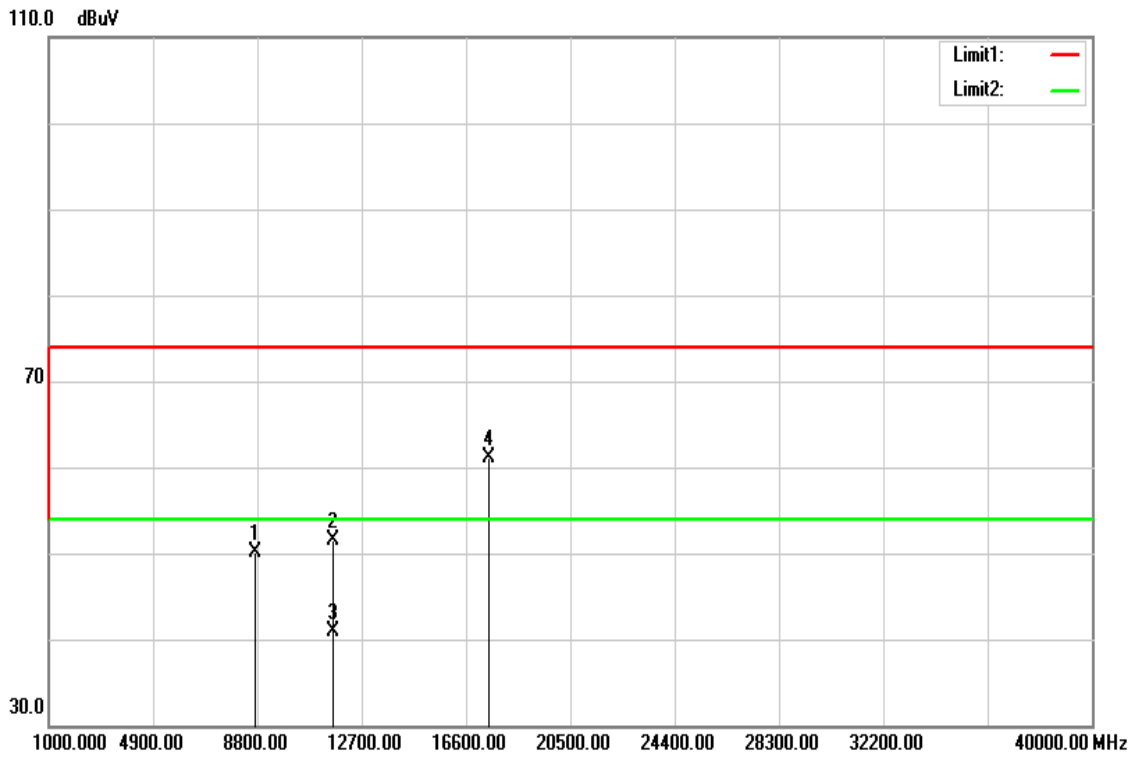

Polarity: Horizontal

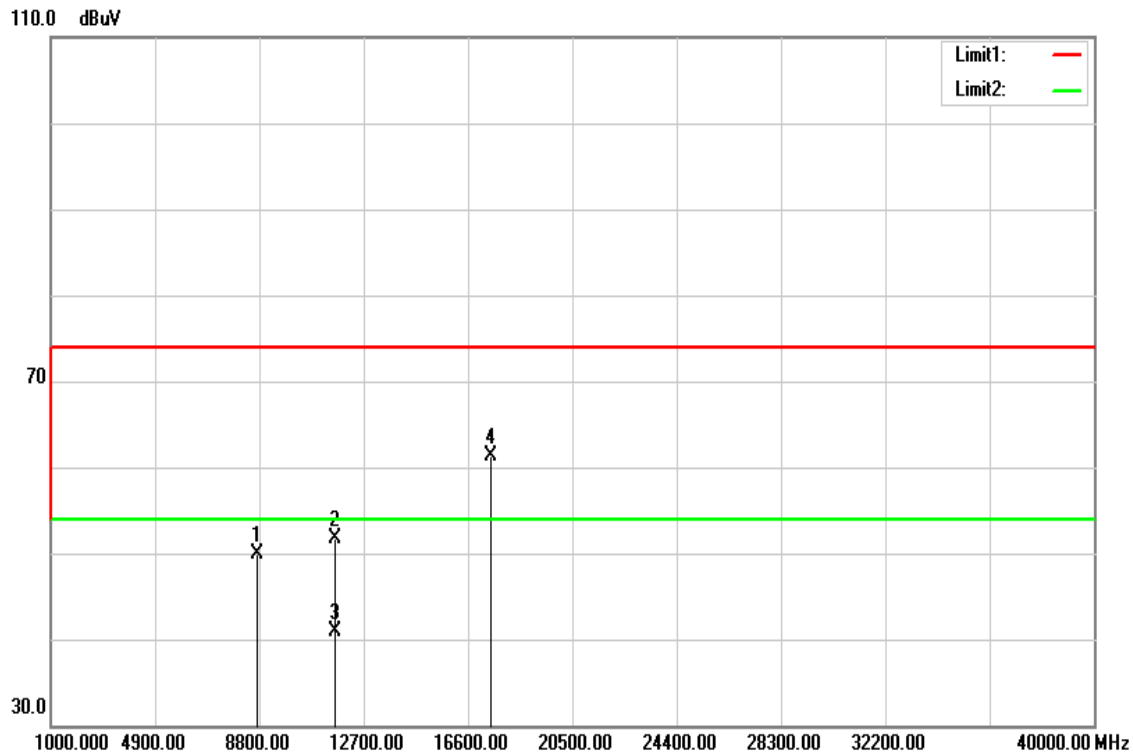

Operation Mode: TX / IEEE 802.11a mode / CH High **Test Date:** June 15, 2016
Temperature: 27°C **Tested by:** Dennis Li
Humidity: 53% RH **Polarity:** Ver. / Hor.

Frequency (MHz)	Reading (dBuV)	Correction (dB/m)	Result (dBuV/m)	Limit (dBuV/m)	Margin (dB)	Remark	Ant.Pol. (H/V)
8745.000	36.36	13.75	50.11	74.00	-23.89	peak	V
11650.000	34.55	16.91	51.46	74.00	-22.54	peak	V
11650.000	24.07	16.91	40.98	54.00	-13.02	AVG	V
17475.000	34.88	26.22	61.10	74.00	-12.90	peak	V
N/A							
8697.000	36.25	13.73	49.98	74.00	-24.02	peak	H
11650.000	34.84	16.91	51.75	74.00	-22.25	peak	H
11650.000	24.07	16.91	40.98	54.00	-13.02	AVG	H
17475.000	35.03	26.22	61.25	74.00	-12.75	peak	H
N/A							

Remark:

1. *Measuring frequencies from 1 GHz to the 10th harmonic of highest fundamental frequency.*
2. *Radiated emissions measured in frequency above 1000MHz were made with an instrument using peak/average detector mode.*
3. *Average test would be performed if the peak result were greater than the average limit.*
4. *Data of measurement within this frequency range shown “ --- ” in the table above means the reading of emissions are attenuated more than 20dB below the permissible limits or the field strength is too small to be measured.*
5. *Measurements above show only up to 6 maximum emissions noted, or would be lesser, with “ N/A ” remark, if no specific emissions from the EUT are recorded (ie: margin>20dB from the applicable limit) and considered that's already beyond the background noise floor.*
6. *Margin (dB) = Remark result (dBuV/m) – Average limit (dBuV/m).*

TX / IEEE 802.11n HT 20 MHz mode / CH Low

Polarity: Vertical

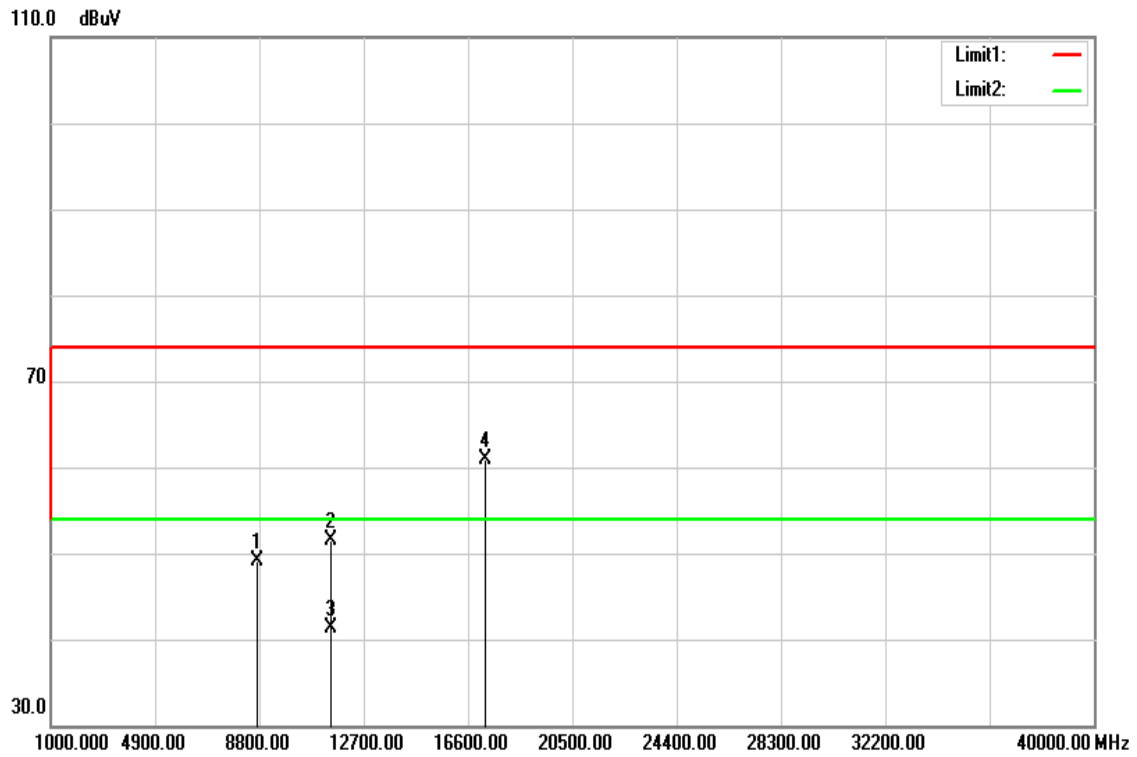

Polarity: Horizontal

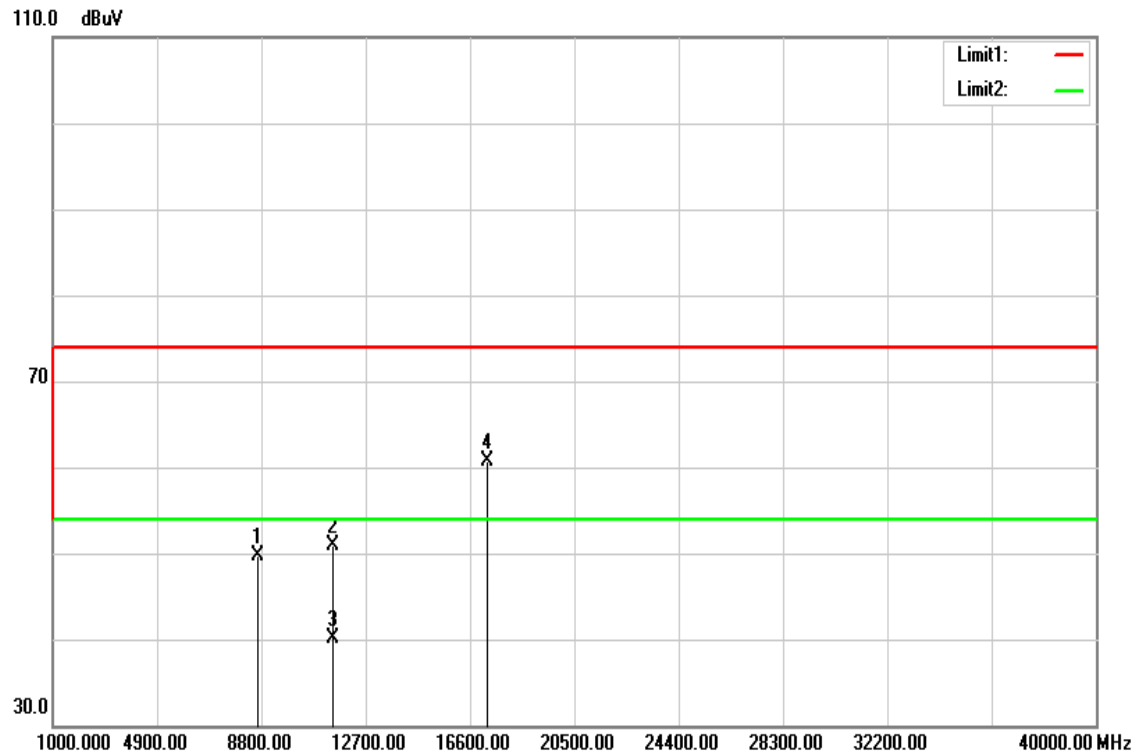

Operation Mode: TX / IEEE 802.11n HT 20 MHz mode / CH Low **Test Date:** June 15, 2016
Temperature: 27°C **Tested by:** Dennis Li
Humidity: 53% RH **Polarity:** Ver. / Hor.

Frequency (MHz)	Reading (dBuV)	Correction (dB/m)	Result (dBuV/m)	Limit (dBuV/m)	Margin (dB)	Remark	Ant.Pol. (H/V)
8709.000	35.35	13.74	49.09	74.00	-24.91	peak	V
11490.000	34.67	16.78	51.45	74.00	-22.55	peak	V
11490.000	24.58	16.78	41.36	54.00	-12.64	AVG	V
17235.000	35.66	25.28	60.94	74.00	-13.06	peak	V
N/A							
8669.000	35.90	13.72	49.62	74.00	-24.38	peak	H
11490.000	34.03	16.78	50.81	74.00	-23.19	peak	H
11490.000	23.34	16.78	40.12	54.00	-13.88	AVG	H
17235.000	35.37	25.28	60.65	74.00	-13.35	peak	H
N/A							

Remark:

1. Measuring frequencies from 1 GHz to the 10th harmonic of highest fundamental frequency.
2. Radiated emissions measured in frequency above 1000MHz were made with an instrument using peak/average detector mode.
3. Average test would be performed if the peak result were greater than the average limit or as required by the applicant.
4. Data of measurement within this frequency range shown “ --- ” in the table above means the reading of emissions are attenuated more than 20dB below the permissible limits or the field strength is too small to be measured.
5. Measurements above show only up to 6 maximum emissions noted, or would be lesser, with “ N/A ” remark, if no specific emissions from the EUT are recorded (ie: margin>20dB from the applicable limit) and considered that's already beyond the background noise floor.
6. Margin (dB) = Remark result (dBuV/m) – Average limit (dBuV/m).

TX / IEEE 802.11n HT 20 MHz mode / CH Mid

Polarity: Vertical

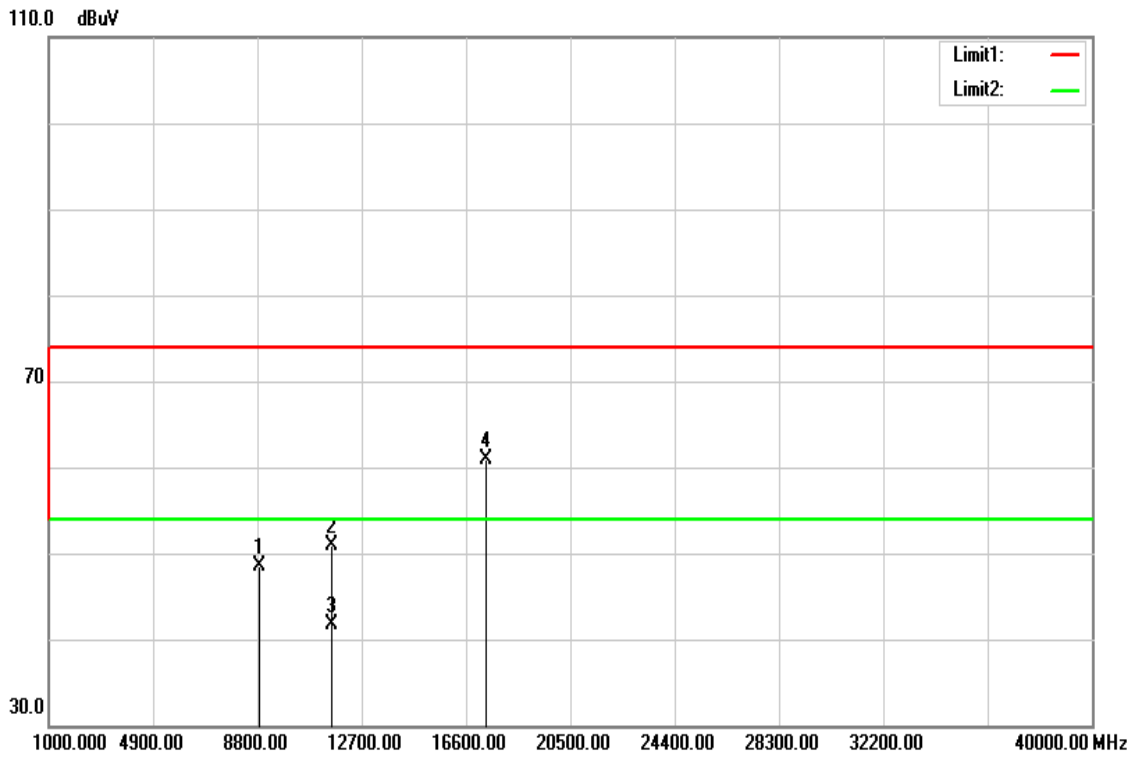

Polarity: Horizontal

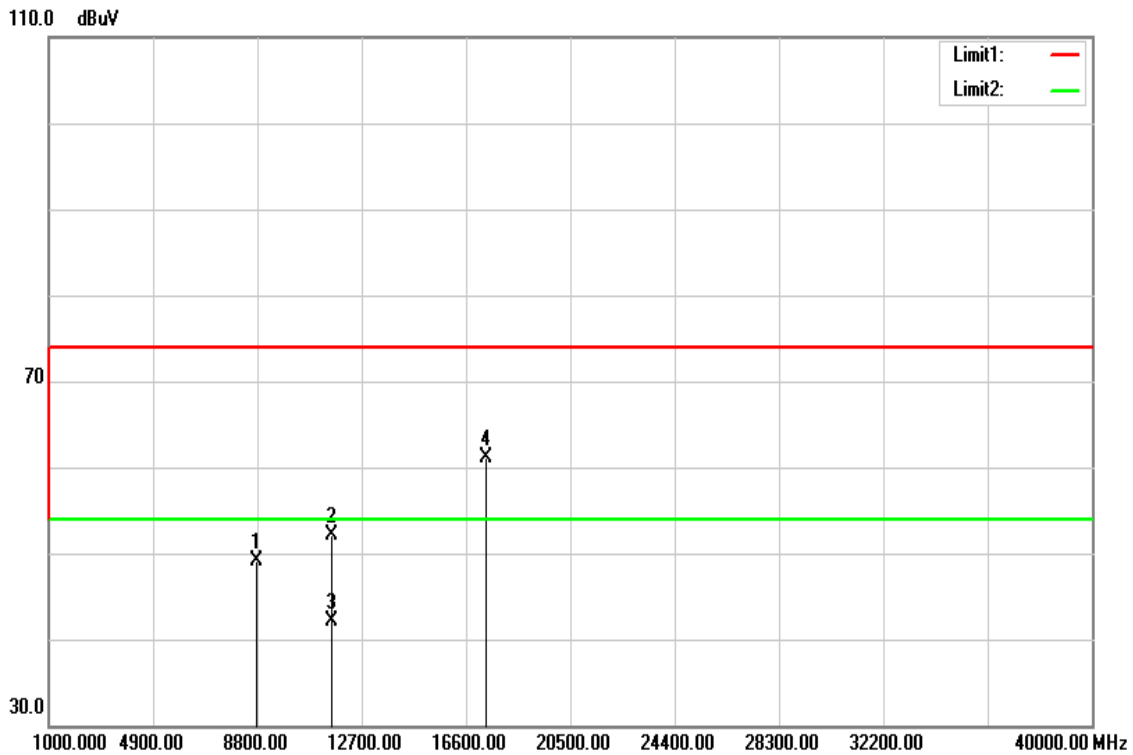

Operation Mode: TX / IEEE 802.11n HT 20 MHz mode / CH Mid

Test Date: June 15, 2016

Temperature: 27°C

Tested by: Dennis Li

Humidity: 53% RH

Polarity: Ver. / Hor.

Frequency (MHz)	Reading (dBuV)	Correction (dB/m)	Result (dBuV/m)	Limit (dBuV/m)	Margin (dB)	Remark	Ant.Pol. (H/V)
8865.000	34.63	13.81	48.44	74.00	-25.56	peak	V
11570.000	34.13	16.84	50.97	74.00	-23.03	peak	V
11570.000	24.94	16.84	41.78	54.00	-12.22	AVG	V
17355.000	35.16	25.75	60.91	74.00	-13.09	peak	V
N/A							
8794.000	35.32	13.78	49.10	74.00	-24.90	peak	H
11570.000	35.33	16.84	52.17	74.00	-21.83	peak	H
11570.000	25.29	16.84	42.13	54.00	-11.87	AVG	H
17355.000	35.36	25.75	61.11	74.00	-12.89	peak	H
N/A							

Remark:

1. Measuring frequencies from 1 GHz to the 10th harmonic of highest fundamental frequency.
2. Radiated emissions measured in frequency above 1000MHz were made with an instrument using peak/average detector mode.
3. Average test would be performed if the peak result were greater than the average limit or as required by the applicant.
4. Data of measurement within this frequency range shown " --- " in the table above means the reading of emissions are attenuated more than 20dB below the permissible limits or the field strength is too small to be measured.
5. Measurements above show only up to 6 maximum emissions noted, or would be lesser, with " N/A " remark, if no specific emissions from the EUT are recorded (ie: margin>20dB from the applicable limit) and considered that's already beyond the background noise floor.
6. Margin (dB) = Remark result (dBuV/m) – Average limit (dBuV/m).

TX / IEEE 802.11n HT 20 MHz mode / CH High

Polarity: Vertical

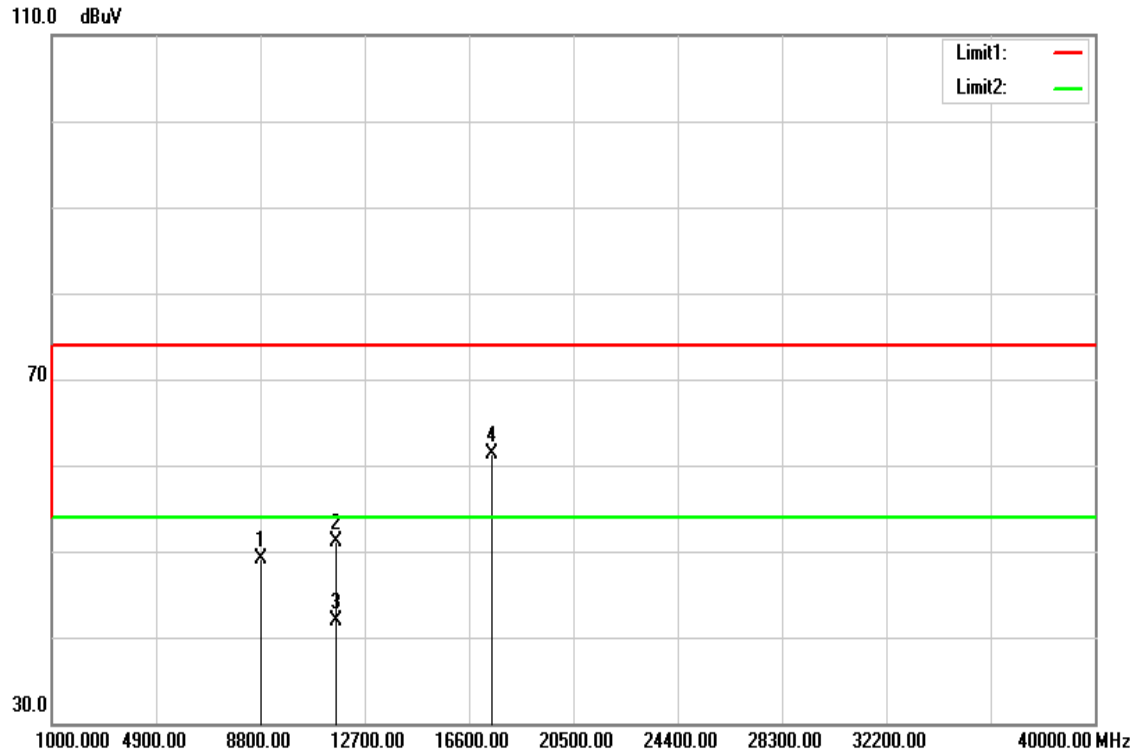

Polarity: Horizontal

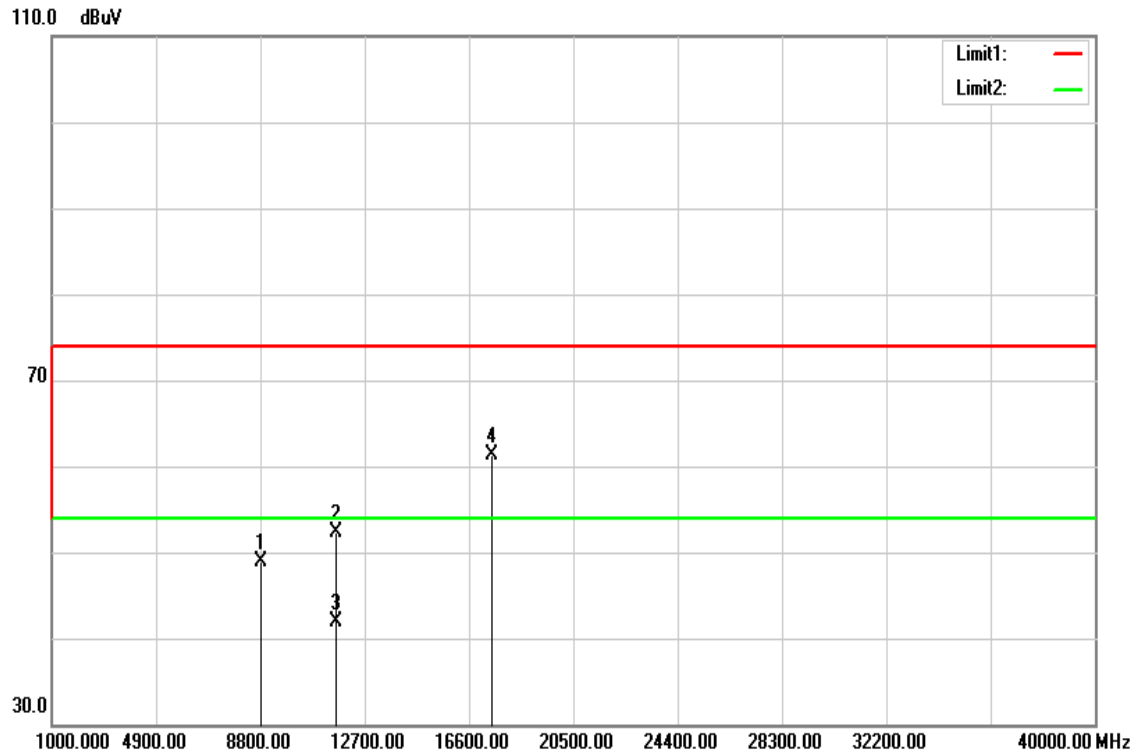

Operation Mode: TX / IEEE 802.11n HT 20 MHz mode / CH High **Test Date:** June 15, 2016
Temperature: 27°C **Tested by:** Dennis Li
Humidity: 53% RH **Polarity:** Ver. / Hor.

Frequency (MHz)	Reading (dBuV)	Correction (dB/m)	Result (dBuV/m)	Limit (dBuV/m)	Margin (dB)	Remark	Ant.Pol. (H/V)
8834.000	35.22	13.79	49.01	74.00	-24.99	peak	V
11650.000	34.22	16.91	51.13	74.00	-22.87	peak	V
11650.000	25.07	16.91	41.98	54.00	-12.02	AVG	V
17475.000	35.10	26.22	61.32	74.00	-12.68	peak	V
N/A							
8841.000	35.09	13.80	48.89	74.00	-25.11	peak	H
11650.000	35.32	16.91	52.23	74.00	-21.77	peak	H
11650.000	25.07	16.91	41.98	54.00	-12.02	AVG	H
17475.000	35.15	26.22	61.37	74.00	-12.63	peak	H
N/A							

Remark:

1. Measuring frequencies from 1 GHz to the 10th harmonic of highest fundamental frequency.
2. Radiated emissions measured in frequency above 1000MHz were made with an instrument using peak/average detector mode.
3. Average test would be performed if the peak result were greater than the average limit or as required by the applicant.
4. Data of measurement within this frequency range shown " --- " in the table above means the reading of emissions are attenuated more than 20dB below the permissible limits or the field strength is too small to be measured.
5. Measurements above show only up to 6 maximum emissions noted, or would be lesser, with " N/A " remark, if no specific emissions from the EUT are recorded (ie: margin>20dB from the applicable limit) and considered that's already beyond the background noise floor.
6. Margin (dB) = Remark result (dBuV/m) – Average limit (dBuV/m).

TX / IEEE 802.11n HT 40 MHz mode / CH Low

Polarity: Vertical

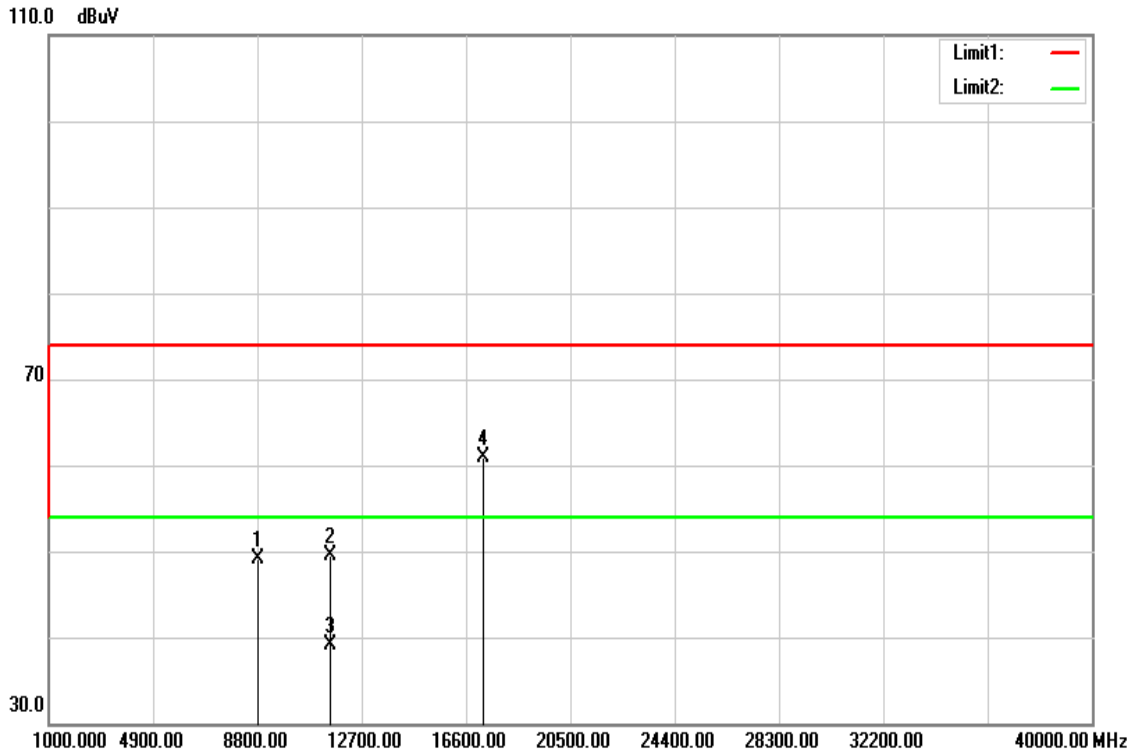

Polarity: Horizontal

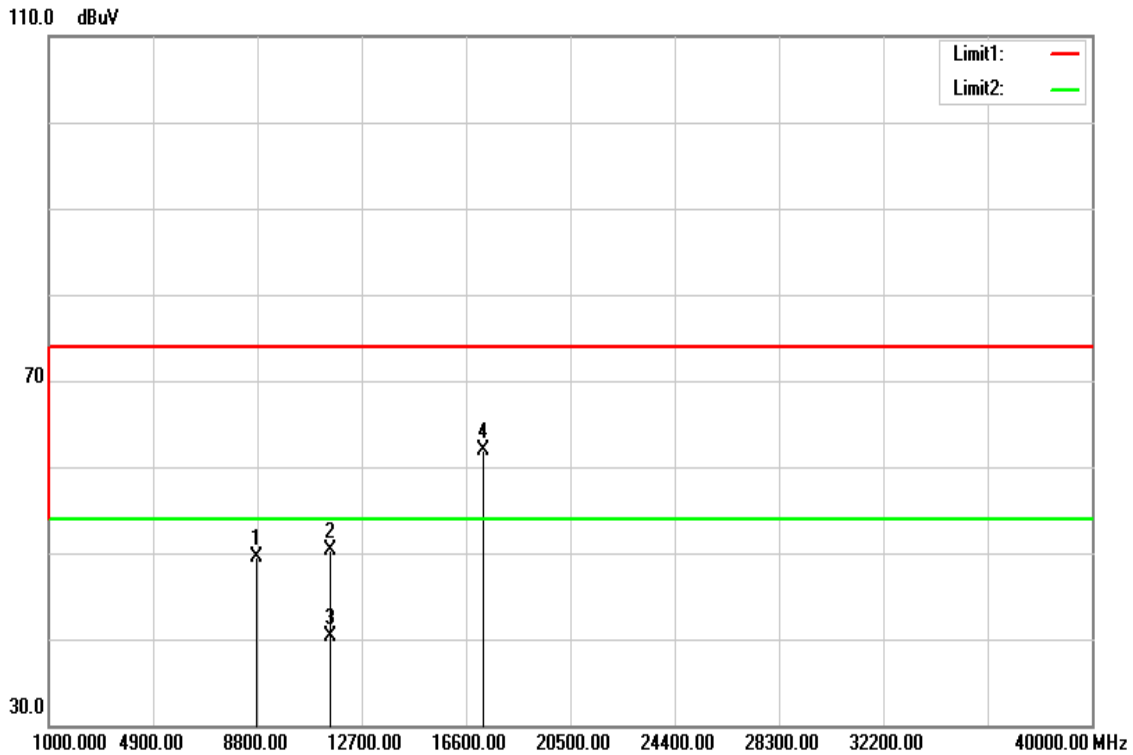

Operation Mode: TX / IEEE 802.11n HT 40 MHz mode
/ CH Low
Temperature: 27°C
Humidity: 53% RH

Test Date: June 15, 2016
Tested by: Dennis Li
Polarity: Ver. / Hor.

Frequency (MHz)	Reading (dBuV)	Correction (dB/m)	Result (dBuV/m)	Limit (dBuV/m)	Margin (dB)	Remark	Ant.Pol. (H/V)
8812.000	35.24	13.78	49.02	74.00	-24.98	peak	V
11510.000	32.75	16.79	49.54	74.00	-24.46	peak	V
11510.000	22.34	16.79	39.13	54.00	-14.87	AVG	V
17265.000	35.59	25.40	60.99	74.00	-13.01	peak	V
N/A							
8799.000	35.63	13.78	49.41	74.00	-24.59	peak	H
11510.000	33.51	16.79	50.30	74.00	-23.70	peak	H
11510.000	23.53	16.79	40.32	54.00	-13.68	AVG	H
17265.000	36.41	25.40	61.81	74.00	-12.19	peak	H
N/A							

Remark:

1. Measuring frequencies from 1 GHz to the 10th harmonic of highest fundamental frequency.
2. Radiated emissions measured in frequency above 1000MHz were made with an instrument using peak/average detector mode.
3. Average test would be performed if the peak result were greater than the average limit or as required by the applicant.
4. Data of measurement within this frequency range shown “ --- ” in the table above means the reading of emissions are attenuated more than 20dB below the permissible limits or the field strength is too small to be measured.
5. Measurements above show only up to 6 maximum emissions noted, or would be lesser, with “ N/A ” remark, if no specific emissions from the EUT are recorded (ie: margin>20dB from the applicable limit) and considered that's already beyond the background noise floor.
6. Margin (dB) = Remark result (dBuV/m) – Average limit (dBuV/m).

TX / IEEE 802.11n HT 40 MHz mode / CH High

Polarity: Vertical

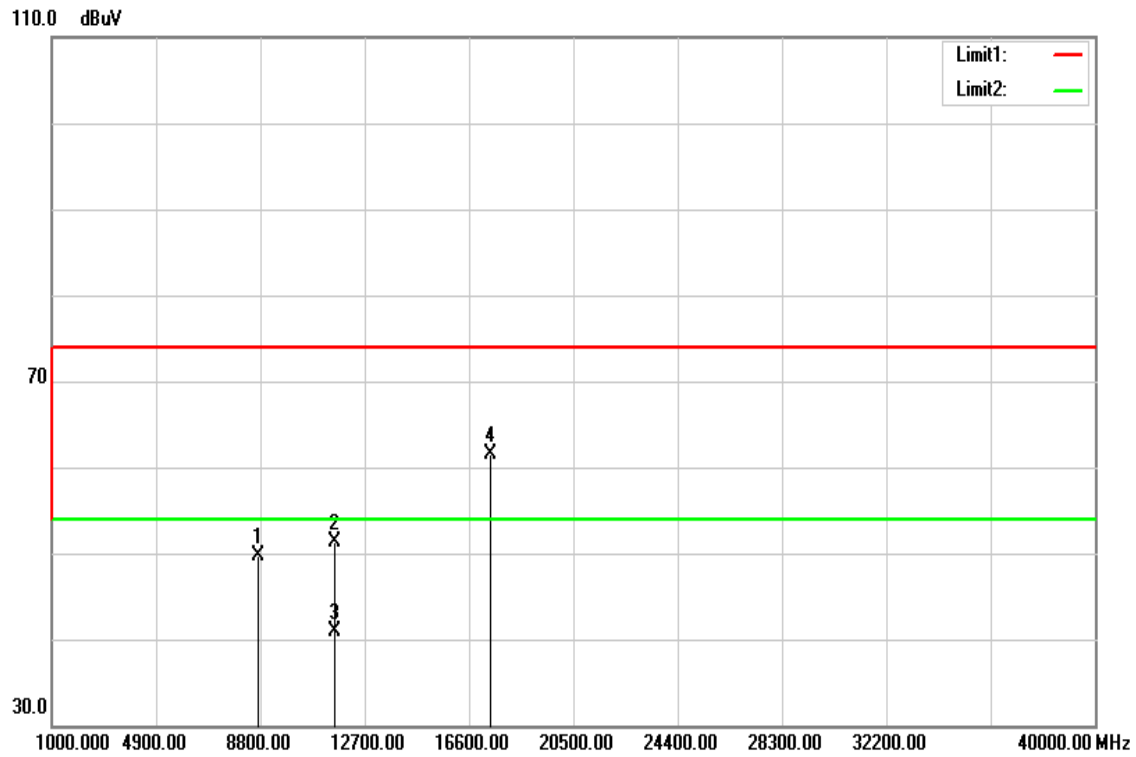

Polarity: Horizontal

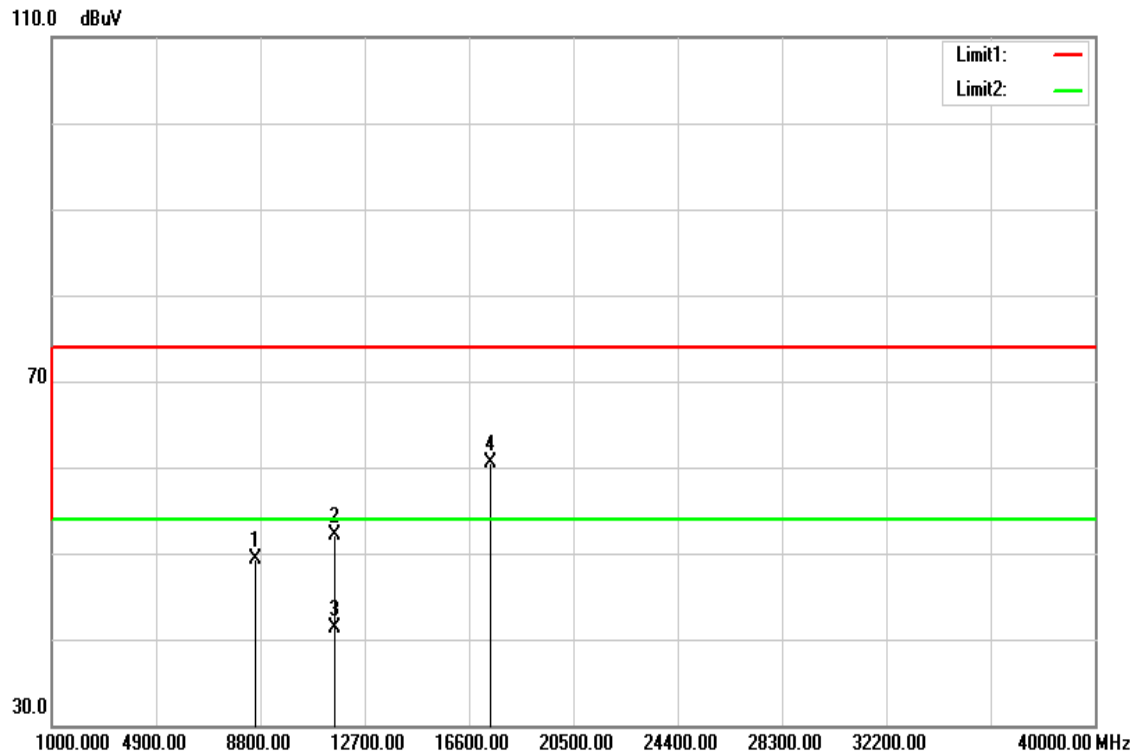

Operation Mode: TX / IEEE 802.11n HT 40 MHz mode
/ CH High

Test Date: June 15, 2016

Temperature: 27°C

Tested by: Dennis Li

Humidity: 53% RH

Polarity: Ver. / Hor.

Frequency (MHz)	Reading (dBuV)	Correction (dB/m)	Result (dBuV/m)	Limit (dBuV/m)	Margin (dB)	Remark	Ant.Pol. (H/V)
8712.000	35.89	13.74	49.63	74.00	-24.37	peak	V
11590.000	34.50	16.86	51.36	74.00	-22.64	peak	V
11590.000	24.11	16.86	40.97	54.00	-13.03	AVG	V
17385.000	35.55	25.87	61.42	74.00	-12.58	peak	V
N/A							
8633.000	35.50	13.70	49.20	74.00	-24.80	peak	H
11590.000	35.33	16.86	52.19	74.00	-21.81	peak	H
11590.000	24.50	16.86	41.36	54.00	-12.64	AVG	H
17385.000	34.71	25.87	60.58	74.00	-13.42	peak	H
N/A							

Remark:

1. Measuring frequencies from 1 GHz to the 10th harmonic of highest fundamental frequency.
2. Radiated emissions measured in frequency above 1000MHz were made with an instrument using peak/average detector mode.
3. Average test would be performed if the peak result were greater than the average limit or as required by the applicant.
4. Data of measurement within this frequency range shown " --- " in the table above means the reading of emissions are attenuated more than 20dB below the permissible limits or the field strength is too small to be measured.
5. Measurements above show only up to 6 maximum emissions noted, or would be lesser, with " N/A " remark, if no specific emissions from the EUT are recorded (ie: margin>20dB from the applicable limit) and considered that's already beyond the background noise floor.
6. Margin (dB) = Remark result (dBuV/m) – Average limit (dBuV/m).

7.6 POWERLINE CONDUCTED EMISSIONS

LIMIT

According to §15.207(a), except as shown in paragraphs (b) and (c) of this section, for an intentional radiator that is designed to be connected to the public utility (AC) power line, the radio frequency voltage that is conducted back onto the AC power line on any frequency or frequencies within the band 150 kHz to 30 MHz shall not exceed the limits in the following table, as measured using a 50 μ H/50 ohms line impedance stabilization network (LISN). Compliance with the provisions of this paragraph shall be based on the measurement of the radio frequency voltage between each power line and ground at the power terminal. The lower limit applies at the boundary between the frequency ranges.

Frequency Range (MHz)	Limits (dB μ V)	
	Quasi-peak	Average
0.15 to 0.50	66 to 56*	56 to 46*
0.50 to 5	56	46
5 to 30	60	50

* DECREASES WITH THE LOGARITHM OF THE FREQUENCY.

Test Configuration

See test photographs attached in Appendix 1 for the actual connections between EUT and support equipment.

TEST PROCEDURE

1. The EUT was placed on a table, which is 0.8m above ground plane.
2. Maximum procedure was performed on the six highest emissions to ensure EUT compliance.
3. Repeat above procedures until all frequency measured were complete.

TEST RESULTS

The initial step in collecting conducted data is a spectrum analyzer peak scan of the measurement range. Significant peaks are then marked as shown on the following data page, and these signals are then quasi-peaked.

Test Data

Operation Mode:	Normal Link	Test Date:	December 16, 2011
Temperature:	22°C	Tested by:	Howard Pang
Humidity:	55% RH		

No.	Frequency (MHz)	Reading (dBuV)	Factor (dB)	Result (dBuV)	Limit (dBuV)	Margin (dB)	Detector	Note
1	0.1500	41.18	10.08	51.26	65.99	-14.73	peak	L1
2	0.1780	40.39	10.04	50.43	64.57	-14.14	peak	L1
3	0.2380	39.15	10.01	49.16	62.16	-13.00	peak	L1
4	1.6940	33.79	10.12	43.91	56.00	-12.09	peak	L1
5	1.9860	33.66	10.15	43.81	56.00	-12.19	peak	L1
6	6.3980	27.64	10.36	38.00	60.00	-22.00	peak	L1
1	0.1819	41.45	10.02	51.47	64.39	-12.92	peak	L2
2	0.2340	37.52	10.00	47.52	62.30	-14.78	peak	L2
3	0.4740	31.50	10.02	41.52	56.44	-14.92	peak	L2
4	1.7340	34.16	10.12	44.28	56.00	-11.72	peak	L2
5	1.9620	36.51	10.14	46.65	56.00	-9.35	peak	L2
6	1.9620	24.72	10.14	34.86	46.00	-11.14	AVG	L2
7	6.3980	27.07	10.35	37.42	60.00	-22.58	peak	L2

Remark:

1. *Measuring frequencies from 0.15 MHz to 30MHz.*
2. *The emissions measured in frequency range from 0.15 MHz to 30MHz were made with an instrument using Quasi-peak detector and average detector.*
3. *The IF bandwidth of SPA between 0.15MHz to 30MHz was 10kHz; the IF bandwidth of Test Receiver between 0.15MHz to 30MHz was 9kHz;*
4. *L1 = Line One (Live Line) / L2 = Line Two (Neutral Line)*

Test Plots

Conducted emissions (Line 1)

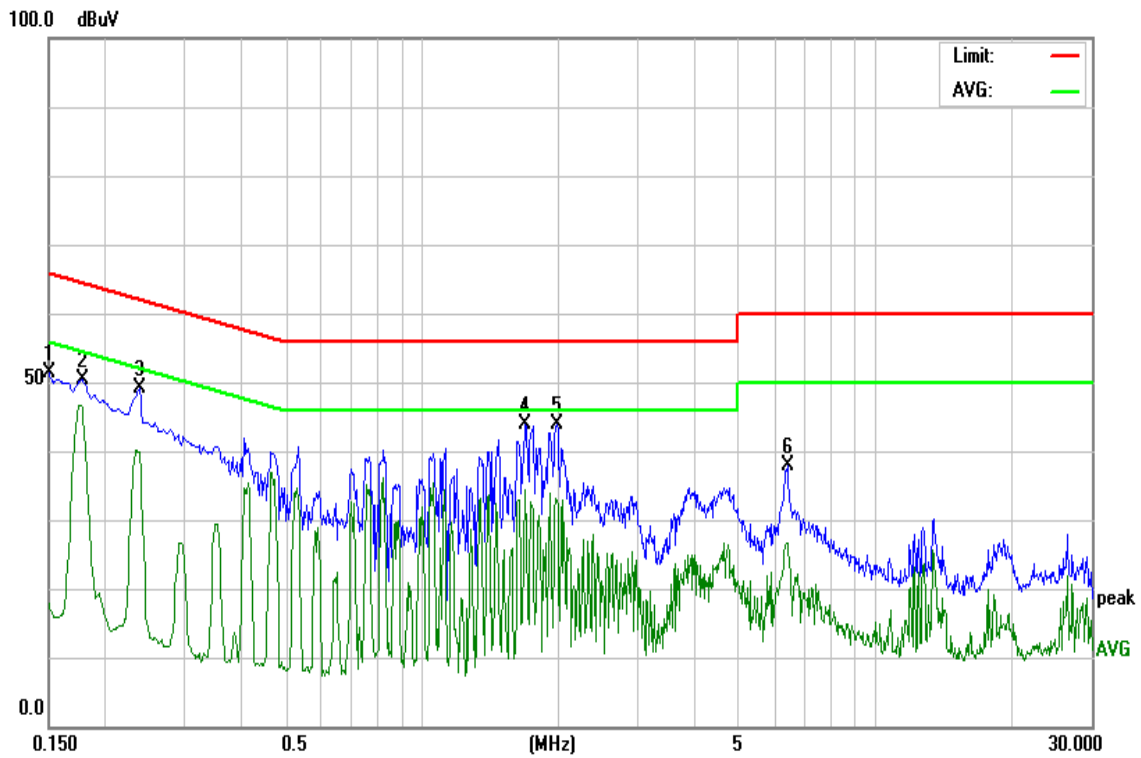

Conducted emissions (Line 2)

