

Intermec Technologies Corporation

Model: 1001CP01S

Evaluated to the following SAR Specifications:

FCC 2.1093: 2011
Health Safety Code 6:2009

Report No. ITRM0248.2

Report Prepared By



www.nwemc.com
1-888-EMI-CERT

© 2011 Northwest EMC, Inc

SAR Evaluation Report

Certificate of Evaluation
Last Date of Test: August 23, 2011
Intermec Technologies Corporation
Model: 1001CP01S

Applicable Standards			
Test Description	Specification	Test Method	Pass/Fail
SAR Evaluation	FCC 2.1093:2011	FCC OET 65C:2001	Pass
		IEEE Std 1528:2003	
		FCC KDB 447498 D01 v04	
		FCC KDB 941225 D01 v02, and D03	
	FCC KDB 648474 D01 v01r05	Pass	
Health Safety Code 6:2009	RSS-102, Issue 4:2010		

Highest SAR Values				
Frequency Band	Head 1g (W/kg)	Body 1g (W/kg)	Limit 1g (W/kg)	Exposure Environment
Cellular	.319	.486	1.6	General Population Uncontrolled
AWS	.596	.854		
PCS	.371	.371		

Modifications made to the product
See the Modifications section of this report

Test Facility

The measurement facility used to collect the data is located at:

Northwest EMC, Inc.
 22975 NW Evergreen Parkway, Suite 400
 Hillsboro, OR 97124

Phone: (503) 844-4066 Fax: 844-3826

Approved By:



Don Facteau, IS Manager



NVLAP Lab Code: 200630-0

This report must not be used to claim product certification, approval, or endorsement by NVLAP, NIST, or any agency of the federal government of the United States of America.

Product compliance is the responsibility of the client, therefore the tests and equipment modes of operation represented in this report were agreed upon by the client, prior to testing. This Report may only be duplicated in its entirety. The results of this test pertain only to the sample(s) tested. The specific description is noted in each of the individual sections of the test report supporting this certificate of test.

Revision Number	Description	Date	Page Number
00	None		

Barometric Pressure

The recorded barometric pressure has been normalized to sea level.



Accreditations and Authorizations

FCC

Accredited by NVLAP for performance of FCC radio, digital, and ISM device testing. Our Open Area Test Sites, certification chambers, and conducted measurement facilities have been fully described in reports filed with the FCC and accepted by the FCC in letters maintained in our files. Northwest EMC has been accredited by ANSI to ISO / IEC Guide 65 as a product certifier. We have been designated by the FCC as a Telecommunications Certification Body (TCB). This allows Northwest EMC to certify transmitters to FCC specifications in accordance with 47 CFR 2.960 and 2.962.

NVLAP

Northwest EMC, Inc. is accredited under the National Voluntary Laboratory Accreditation Program (NVLAP) for satisfactory compliance with the requirements of ISO/IEC 17025 for Testing Laboratories. NVLAP is administered by the National Institute of Standards and Technology (NIST), an agency of the U.S. Commerce Department. The NVLAP accreditation encompasses Electromagnetic Compatibility Testing in accordance with the European Union EMC Directive 2004/108/EC, and ANSI C63.4. Additionally, Northwest EMC is accredited by NVLAP to perform radio testing in accordance with the European Union R&TTE Directive 1999/5/EEC, the requirements of FCC, and the RSS radio standards for Industry Canada.

Industry Canada

Accredited by NVLAP for performance of Industry Canada RSS and ICES testing. Our Open Area Test Sites and certification chambers comply with RSS-Gen, Issue 2 and have been filed with Industry Canada and accepted. Northwest EMC has been accredited by ANSI to ISO / IEC Guide 65 as a product certifier. We have been designated by NIST and recognized by Industry Canada as a Certification Body (CB) per the APEC Mutual Recognition Arrangement (MRA). This allows Northwest EMC to certify transmitters to Industry Canada technical requirements. (*Site Filing Numbers - Hillsboro: 2834D-1, 2834D-2, Sultan: 2834C-1, Irvine: 2834B-1, 2834B-2, Brooklyn Park: 2834E-1*)

CAB

Designated by NIST and validated by the European Commission as a Conformity Assessment Body (CAB) to conduct tests and approve products to the EMC directive and transmitters to the R&TTE directive, as described in the U.S. - EU Mutual Recognition Agreement.

Australia/New Zealand

The National Association of Testing Authorities (NATA), Australia has been appointed by the ACA as an accreditation body to accredit test laboratories and competent bodies for EMC standards. Accredited test reports or assessments by competent bodies must carry the NATA logo. Test reports made by an overseas laboratory that has been accredited for the relevant standards by an overseas accreditation body that has a Mutual Recognition Agreement (MRA) with NATA are also accepted as technical grounds for product conformity. The report should be endorsed with the respective logo of the accreditation body (NVLAP).



Accreditations and Authorizations

VCCI

Accepted as an Associate Member to the VCCI, Acceptance No. 564. Conducted and radiated measurement facilities have been registered in accordance with Regulations for Voluntary Control Measures, Article 8. (*Registration Numbers. - Hillsboro: C-1071, R-1025, G-84, C-2687, T-1658, and R-2318, Irvine: R-1943, G-85, C-2766, and T-1659, Sultan: R-871, G-83, C-1784, and T-1511, Brooklyn Park: R-3125, G-86, G-141, C-3464, and T-1634.*)

BSMI

Northwest EMC has been designated by NIST and validated by C-Taipei (BSMI) as a CAB to conduct tests as described in the APEC Mutual Recognition Agreement (US0017).

GOST

Northwest EMC, Inc. has been assessed and accredited by the Russian Certification bodies Certinform VNIINMASH, CERTINFO, SAMTES, and Federal CHEC, to perform EMC and Hygienic testing for Information Technology Products. As a result of their laboratory assessment, they will accept test results from Northwest EMC, Inc. for product certification

KCC

Northwest EMC, Inc is a CAB designated by MRA partners and recognized by Korea. (*Assigned Lab Numbers: Hillsboro: US0017, Irvine: US0158, Sultan: US0157, Brooklyn Park: US0175*)

VIETNAM

Vietnam MIC has approved Northwest EMC as an accredited test lab. Per Decision No. 194/QD-QLCL (dated December 15, 2009), Northwest EMC test reports can be used for Vietnam approval submissions.

SCOPE

For details on the Scopes of our Accreditations, please visit:

<http://www.nwemc.com/accreditations/>



Northwest EMC Locations



Oregon
Labs EV01-EV12
22975 NW Evergreen Pkwy
Suite 400
Hillsboro, OR 97124
(503) 844-4066

California
Labs OC01-OC13
41 Tesla
Irvine, CA 92618
(949) 861-8918

Minnesota
Labs MN01-MN08
9349 W Broadway Ave.
Brooklyn Park,
MN 55445
(763) 425-2281

Washington
Labs SU01-SU07
14128 339th Ave. SE
Sultan, WA 98294
(360) 793-8675

New York
Labs WA01-WA04
4939 Jordan Rd.
Elbridge, NY 13060
(315) 685-0796

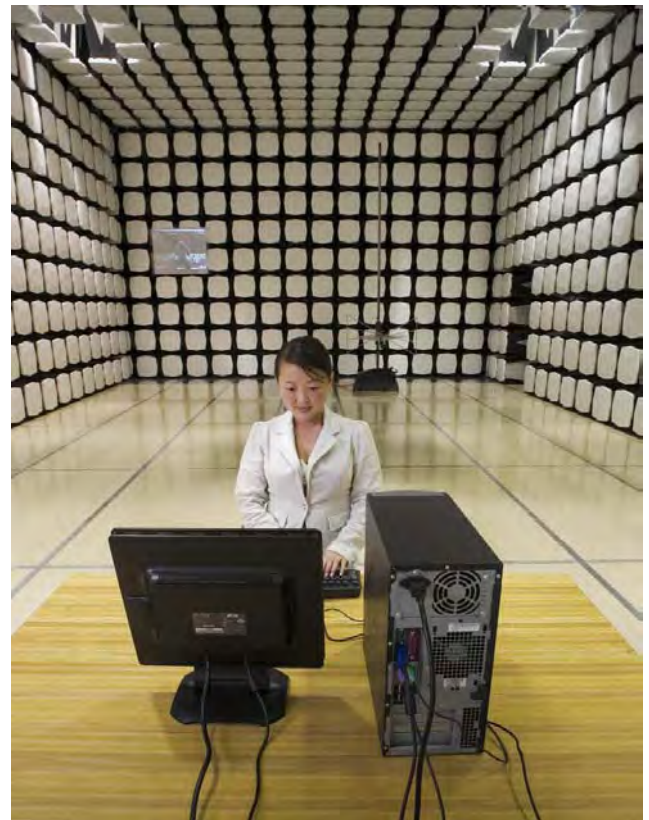
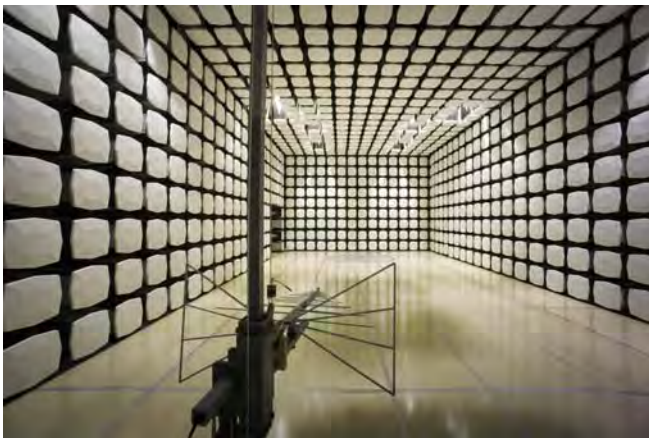

Party Requesting the Test

Company Name:	Intermec Technologies Corporation
Address:	6001 36 th Avenue West
City, State, Zip:	Everett, WA 98203-1264
Test Requested By:	Wayne Rieger
Model:	1001CP01S
First Date of Test:	August 8, 2011
Last Date of Test:	August 23, 2011
Receipt Date of Samples:	July 19, 2011
Equipment Design Stage:	Production
Equipment Condition:	No Damage

Information Provided by the Party Requesting the Test

Functional Description of the EUT (Equipment Under Test)

The EUT is a handheld computer containing two radio modules, the Intermec Model RC12 and the Sierra Wireless MC8355, each with their own integral antenna.

The Intermec Model RC12 radio module is an 802.11a/b/g/n – Bluetooth radio. It is not capable of 40 MHz channel operation. The 802.11a/b/g/n and Bluetooth radios share the same antenna, but cannot transmit simultaneously. The frequency range of the 802.11a/b/g/n radio:

- 2412 – 2462 MHz
- 5180 – 5320 MHz
- 5500 – 5700 MHz
- 5745 – 5825 MHz

The frequency range of the Bluetooth radio:

- 2402 – 2480 MHz

The Sierra Wireless MC8355 radio module is a UMTS radio. Its frequency range:

- 824.2 – 848.8 MHz (GPRS, EDGE)
- 826.4 – 846.6 MHz (WCDMA, HSDPA, HSUPA)
- 1850.2 – 1909.8 MHz (GPRS, EDGE)
- 1852.4 – 1907.5 MHz (WCDMA, HSDPA, HSUPA)
- 1712.4 – 1752.6 MHz (WCDMA)

The closest spacing between the UMTS antenna and 802.11a/b/g/n antenna is 3.7cm. The 802.11a/b/g/n antenna is on the right side of the handheld computer and the UMTS antenna is on the left side.

In normal operation, the EUT can be held in the hand, or next to the head like a cellular handset, or worn on the body. The only Intermec approved accessory for body worn operation is a holster that contains metal. The EUT can only fit in the holster with the top end of the unit pointing down. The holster cup can be attached to the holster belt with either the keypad facing the user, or the side facing the user. In no case can the back of the EUT face the user.

An optional snap-on audio accessory is available. It connects to the bottom end of the unit and provides a standard audio jack for connection of a VR10 headset.

The EUT is powered by a lithium-ion battery, Model 1001AB01.

Overview of the SAR Evaluation**Objective**

To demonstrate compliance with the SAR requirements of FCC 2.1093 and Canada's Health Safety Code 6.

Scope

The 802.11a/b/g/n – Bluetooth radio was evaluated under a separate SAR evaluation report.

Regarding the UMTS radio:

KDB 648474 D01 is the FCC's Policy for SAR evaluation of handsets with multiple transmitters and antennas. It states:

“Routine SAR evaluation with respect to Section 2.1093 of the rules is required for licensed transmitter to show compliance,”

The SAR evaluation documented in this report is for the UMTS portion of the EUT.

CONFIGURATION 7 ITRM0248**Software/Firmware Running during test**

Description	Version
Regulatory Test Tool	1.01.00.0016

EUT

Description	Manufacturer	Model/Part Number	Serial Number
C1 Handheld Computer	Intermec Technologies Corporation	1001CP01S	28311047275
C1 Holster	Intermec Technologies Corporation	X11236-V1	None
C1 Battery	Intermec Technologies Corporation	1001AB01	1666100990

CONFIGURATION 8 ITRM0248**Software/Firmware Running during test**

Description	Version
Regulatory Test Tool	1.01.00.0016

EUT

Description	Manufacturer	Model/Part Number	Serial Number
C1 Handheld Computer	Intermec Technologies Corporation	1001CP01S	28311047275
C1 Holster	Intermec Technologies Corporation	X11236-V1	None
Headset	Intermec Technologies Corporation	VR10	None
Standard Audio Snap-On	Intermec Technologies Corporation	225-771-001	Proto 2
C1 Battery	Intermec Technologies Corporation	1001AB01	1666100990

Cables

Cable Type	Shield	Length (m)	Ferrite	Connection 1	Connection 2
Audio Accessory	PA		PA	udio Accessory - Headset	Handheld Computer

PA = Cable is permanently attached to the device. Shielding and/or presence of ferrite may be unknown.

CONFIGURATION 9 ITRM0248**Software/Firmware Running during test**

Description	Version
Regulatory Test Tool	1.01.00.0016

EUT

Description	Manufacturer	Model/Part Number	Serial Number
C1 Handheld Computer	Intermec Technologies Corporation	1001CP01S	28311047275
C1 Battery	Intermec Technologies Corporation	1001AB01	1666100990

Equipment modifications					
Item	Date	Test	Modification	Note	Disposition of EUT
1	8/8/11	SAR Evaluation	Tested as delivered to Test Station.	No EMI suppression devices were added or modified during this test.	EUT remained at Northwest EMC following the test.
2	8/23/11	SAR Evaluation	Tested as delivered to Test Station.	No EMI suppression devices were added or modified during this test.	Scheduled testing was completed.

Per FCC KDB 941225, the conducted output power was measured at the low, middle and high channels in each band. An Agilent 8960 test set, Model E5515C, was used to control the EUT. The following applications were installed on the test set: GSM/GPRS Mobile Test A.13.12 and WCDMA Mobile Test A.17.10. This provided all the necessary tools to operate the EUT in the prescribed manner without any difficulties or equipment limitations.

Per KDB 648474, among the channels required for normal testing, SAR must be measured on the highest conducted output channel (highlighted in the following pages). When the SAR measured on the highest output channel is < 0.8 W/kg, SAR evaluation for the other required channels is unnecessary.

GPRS and EDGE

Per FCC KDB 941225 D03, "SAR must be measured according to these maximum output conditions"

- Maximum output power is verified on the High, Middle, and Low channels
- When multiple slots can be used, the device should be tested to account for the maximum source-based time-averaged output power. Measure GMSK and 8PSK modulations for both one and two time slots.
- When measuring EDGE or EGPRS modes, GMSK modulation should be used to minimize measurement error due to higher peak-to-average power (PAR) ratios inherent in 8-PSK

Results of the power measurement procedure are tabulated on the following pages.

WCDMA, HSDPA, HSUPA

Per FCC KDB 941225 D01 V02, measurements for WCDMA, HSDPA, and HSUPA were made according to the procedures in section section 5.2 of 3GPP2 TS 34.121.

- Maximum output power is verified on the High, Middle, and Low channels
- Use the appropriate RMC or AMR with TPC (transmit power control) set to all "1"s for WCDMA/HSDPA or applying the required inner loop power control procedures to maintain maximum output power while HSUPA is active. Maximum output power for all applicable physical channel configurations (DPCCH, DPDCHn and spreading codes, HSDPA, HSPA) should be measured
- Voice mode is measured using a 12.2 kbps RMC with TPC bits configured to all "1"s.
- 12.2 kbps AMR is measured with a 3.4 kbps SRB (signaling radio bearer)
- HSPA is measured with HS-DPCCH, E-DPCCH and E-DPDCH all enabled and a 12.2 kbps RMC. FRC is configured according to HS-DPCCH Sub-Test 1 using H-set 1 and QPSK.

The results are tabulated on the following pages.

The Agilent 8960 test set was configured as follows:

WCDMA Rel99

- Set a Test Mode 1 loop back with a 12.2 kbps Reference Measurement Channel (RMC).
- Set and send continuously Up power control commands to the EUT.

HSDPA Rel 6

- Use the “34.121 Preset Call Configs” within the Agilent 8960 which provide the required settings per the defined tables.
- Establish a Test Mode 1 loop back with both 12.2 kbps RMC channel and a Fixed Reference Channel (FRC) using H-Set 1 and QPSK
- Send continuously Up power control commands to the EUT.
- Repeat measurements for HSDPA Subtest 2, 3 and 4

HSUPA Rel 6

- Use the “34.121 Preset Call Configs” within the Agilent 8960 which provide the required settings per the defined tables.
- Use UL RMC 12.2 kbps and FRC H-Set 1 and QPSK, Test Mode 1 loop back.
- Set the Absolute Grant for HSPA Subtest 1 according to the defined tables.
- Set the EUT power to be at least 5 dB lower than the maximum output power
- Send power control bits to give one TPC_cmd = +1 command to the EUT. If the EUT doesn't send any E-DPCH data with decreased E-TFCl within 500 ms, then repeat this process until the decreased E-TFCl is reported.
- Confirm that the E-TFCl transmitted by the EUT is equal to the target E-TFCl in the defined table. If the E-TFCl transmitted by the EUT is not equal to the target E-TFCl, then send power control bits to give one TPC_cmd = -1 command to the EUT. If the EUT sends any E-DPCH data with decreased E-TFCl within 500ms, send new power control bits to give one TPC_cmd = -1 command to the EUT. Then confirm that the E-TFCl transmitted by the EUT is equal to the target E-TFCl in the defined table
- Repeat measurements for HSUPA Subtest 2, 3, 4 and 5.

EUT: 1001CP01S		Work Order: ITRM0248
Serial Number: 28311047275		Date: 07/19/11
Customer: Intermec Technologies Corporation		Temperature: 23
Attendees: None		Humidity: 49%
Project: ITRM0227		Barometric Pres.: 30.01"
Tested by: Rod Peloquin	EUT Power	Battery
Job Site: EV12		
TEST SPECIFICATIONS		
FCC 2.1093:2011		Test Method
		FCC OET 65C:2001
COMMENTS		
Conducted output power		
DEVIATIONS FROM TEST STANDARD		
None		
Configuration #	9	<i>Rodry Le Felings</i> Signature

GPRS / 1 slot		
Band	Channel	Power BAP
Cellular	128	32.57
	190	32.53
	251	32.52
PCS	512	29.28
	661	29.57
	810	29.09

GPRS / 2 slot		
Band	Channel	Power BAP
Cellular	128	32.56
	190	32.55
	251	32.33
PCS	512	29.20
	661	29.46
	810	28.97

E-GPRS / 1 slot / GMSK (MCS-4)		
Band	Channel	Power BAP
Cellular	128	32.70
	190	32.69
	251	32.45
PCS	512	29.04
	661	29.31
	810	29.14

E-GPRS / 2 slot / GMSK (MCS-4)		
Band	Channel	Power BAP
Cellular	128	32.44
	190	32.48
	251	32.27
PCS	512	28.84
	661	29.12
	810	28.97

EUT: 1001CP01S	Work Order: ITRM0248
Serial Number: 28311047275	Date: 07/20/11
Customer: Intermec Technologies Corporation	Temperature: 23
Attendees: None	Humidity: 45%
Project: ITRM0227	Barometric Pres.: 30.16"
Tested by: Rod Peloquin	Job Site: EV12
EUT Power	Battery
TEST SPECIFICATIONS	
FCC 2.1093:2011	Test Method FCC OET 65C:2001
COMMENTS	
Conducted output power	
DEVIATIONS FROM TEST STANDARD	
None	
Configuration #	4
	<i>Rod Peloquin</i> Signature

3GPP Release Version	Mode	Cellular Band MAP (dBm)			Sub-Test (See Table)
		4132	4183	4233	
99	WCDMA	24.46	24.50	24.41	
6	HSDPA	23.68	23.91	23.91	1
6		23.92	23.94	23.86	2
6		23.37	23.52	23.37	3
6		23.47	23.39	23.36	4
6	HSUPA	23.63	23.96	23.18	1
6		22.35	22.40	22.58	2
6		22.33	22.68	22.44	3
6		23.23	22.80	22.71	4
6		23.49	23.54	23.44	5

3GPP Release Version	Mode	PCS Band MAP (dBm)			Sub-Test (See Table)
		9262	9400	9538	
99	WCDMA	24.45	24.54	24.52	
6	HSDPA	24.15	24.10	23.96	1
6		24.14	24.19	23.87	2
6		23.64	23.53	23.50	3
6		23.60	23.62	23.45	4
6	HSUPA	23.33	24.06	23.80	1
6		22.71	22.77	22.34	2
6		22.92	22.68	22.67	3
6		23.02	22.88	22.82	4
6		23.57	23.65	23.50	5

3GPP Release Version	Mode	AWS Band MAP (dBm)			Sub-Test (See Table)
		1312	1427	1513	
99	WCDMA	23.90	23.99	23.99	
6	HSDPA	23.47	23.52	23.54	1
6		23.46	23.55	23.49	2
6		22.96	23.04	22.94	3
6		22.89	22.97	23.06	4
6	HSUPA	23.39	23.51	23.44	1
6		22.02	21.79	22.18	2
6		22.37	22.39	22.32	3
6		22.39	22.44	22.45	4
6		23.51	23.39	23.38	5

Characterization of tissue-equivalent liquid dielectric properties

Per IEEE 1528: 2003, Section 5.2.2, the permittivity and conductivity of the tissue material should be measured at least within 24 hours of any full-compliance test. The measured values must be within +/- 5% of the target values. The temperature variation in the liquid during SAR measurements must be within +/- 2 degrees C of that recorded when the dielectric properties were measured.

The dielectric parameters of the tissue-equivalent liquids were measured within 24 hours of testing using the HP85070E dielectric probe kit. The dielectric measurements were made at 50 MHz intervals. The attached data sheets show that the dielectric parameters of the liquid were within the required 5% tolerances.

Target values of dielectric parameters

Per FCC OET 65C, Appendix C:

“The head tissue dielectric parameters recommended by the IEEE SCC-34/SC-2 in P1528 have been incorporated in the following table. These head parameters are derived from planar layer models simulating the highest expected SAR for the dielectric properties and tissue thickness variations in a human head. Other head and body tissue parameters that have not been specified in P1528 are derived from the tissue dielectric parameters computed from the 4-Cole-Cole equations and extrapolated according to the head parameters specified in P1528.”

Target Frequency (MHz)	Head		Body	
	ϵ_r	σ (S/m)	ϵ_r	σ (S/m)
150	52.3	0.76	61.9	0.80
300	45.3	0.87	58.2	0.92
450	43.5	0.87	56.7	0.94
835	41.5	0.90	55.2	0.97
900	41.5	0.97	55.0	1.05
915	41.5	0.98	55.0	1.06
1450	40.5	1.20	54.0	1.30
1610	40.3	1.29	53.8	1.40
1800 – 2000	40.0	1.40	53.3	1.52
2450	39.2	1.80	52.7	1.95
3000	38.5	2.40	52.0	2.73
5800	35.3	5.27	48.2	6.00

(ϵ_r = relative permittivity, σ = conductivity and $\rho = 1000 \text{ kg/m}^3$)

Composition of Ingredients for Liquid Tissue Phantoms

Northwest EMC uses tissue-equivalent liquids prepared by SPEAG and confirmed by them to be within +/- 5% from the target values. Their recipes are based upon the following formulations as found in FCC OET 65C, Appendix C:

“The following tissue formulations are provided for reference only as some of the parameters have not been thoroughly verified. The composition of ingredients may be modified accordingly to achieve the desired target tissue parameters required for routine SAR evaluation.”

Ingredients (% by weight)	Frequency (MHz)									
	450		835		915		1900		2450	
Tissue Type	Head	Body	Head	Body	Head	Body	Head	Body	Head	Body
Water	38.56	51.16	41.45	52.4	41.05	56.0	54.9	40.4	62.7	73.2
Salt (NaCl)	3.95	1.49	1.45	1.4	1.35	0.76	0.18	0.5	0.5	0.04
Sugar	56.32	46.78	56.0	45.0	56.5	41.76	0.0	58.0	0.0	0.0
HEC	0.98	0.52	1.0	1.0	1.0	1.21	0.0	1.0	0.0	0.0
Bactericide	0.19	0.05	0.1	0.1	0.1	0.27	0.0	0.1	0.0	0.0
Triton X-100	0.0	0.0	0.0	0.0	0.0	0.0	0.0	0.0	36.8	0.0
DGBE	0.0	0.0	0.0	0.0	0.0	0.0	44.92	0.0	0.0	26.7
Dielectric Constant	43.42	58.0	42.54	56.1	42.0	56.8	39.9	54.0	39.8	52.5
Conductivity (S/m)	0.85	0.83	0.91	0.95	1.0	1.07	1.42	1.45	1.88	1.78

Salt: 99⁺% Pure Sodium Chloride

Sugar: 98⁺% Pure Sucrose

Water: De-ionized, 16 M Ω ⁺ resistivity

HEC: Hydroxyethyl Cellulose

DGBE: 99⁺% Di(ethylene glycol) butyl ether, [2-(2-butoxyethoxy)ethanol]

Triton X-100 (ultra pure): Polyethylene glycol mono [4-(1,1, 3, 3-tetramethylbutyl)phenyl]ether

NORTHWEST		EMC		Tissue - Equivalent Liquid		SAR 2011.02.21	
EUT: MSL900				Work Order: ITRM0248			
Serial Number: SAT				Date: 08/08/11			
Customer: Intermec Technologies Corporation				Temperature (°C): 23.1			
Attendees: None				Humidity: 43.4			
Project: ITRM0227				Barometric Pres. (mb): 1018.4			
Tested by: Jennifer Herrett				Power: None			
Job Site: Cal Lab							
TEST SPECIFICATIONS				Test Method			
FCC 2.1093:2011				FCC OET 65C:2001			
COMMENTS							
None							
DEVIATIONS FROM TEST STANDARD							
None							
Configuration #	None			Signature <i>Jennifer Herrett</i>			
Tissue: MSL900				Liquid Temperature (°C): 22			

Frequency (GHz)	Actual Values		Target Values		Deviation (%)	
	Relative Permittivity	Conductivity	Relative Permittivity	Conductivity	Relative Permittivity	Conductivity
835	56.512	1.011	55.200	0.970	-2.38	-4.24
700.0	57.7	0.887				
705.0	57.7	0.892				
710.0	57.7	0.896				
715.0	57.6	0.901				
720.0	57.6	0.906				
725.0	57.5	0.910				
730.0	57.4	0.915				
735.0	57.4	0.920				
740.0	57.3	0.924				
745.0	57.3	0.929				
750.0	57.2	0.933				
755.0	57.2	0.938				
760.0	57.1	0.943				
765.0	57.1	0.947				
770.0	57.0	0.952				
775.0	57.0	0.957				
780.0	56.9	0.961				
785.0	56.9	0.966				
790.0	56.8	0.970				
795.0	56.8	0.975				
800.0	56.7	0.979				
805.0	56.7	0.983				
810.0	56.7	0.988				
815.0	56.6	0.992				
820.0	56.6	0.996				
825.0	56.6	1.001				
830.0	56.5	1.006				
835.0	56.5	1.011				
840.0	56.5	1.017				
845.0	56.4	1.022				
850.0	56.4	1.028				
855.0	56.3	1.033				
860.0	56.3	1.038				
865.0	56.2	1.043				
870.0	56.2	1.048				
875.0	56.2	1.053				
880.0	56.1	1.058				
885.0	56.1	1.062				
890.0	56.0	1.067				
895.0	56.0	1.072				
900.0	55.9	1.077				
905.0	55.9	1.083				
910.0	55.8	1.087				
915.0	55.8	1.092				
920.0	55.7	1.097				
925.0	55.7	1.103				
930.0	55.6	1.107				
935.0	55.6	1.112				
940.0	55.6	1.116				
945.0	55.5	1.122				
950.0	55.5	1.126				
955.0	55.4	1.131				
960.0	55.4	1.136				
965.0	55.3	1.140				
970.0	55.3	1.145				
975.0	55.3	1.150				
980.0	55.2	1.155				
985.0	55.2	1.160				
990.0	55.2	1.165				
995.0	55.1	1.170				
1000.0	55.1	1.175				
1005.0	55.0	1.180				
1010.0	55.0	1.186				
1015.0	54.9	1.190				
1020.0	54.9	1.196				
1025.0	54.9	1.201				
1030.0	54.8	1.206				
1035.0	54.8	1.211				
1040.0	54.8	1.217				
1045.0	54.7	1.223				
1050.0	54.7	1.229				
1055.0	54.6	1.234				
1060.0	54.6	1.240				
1065.0	54.6	1.245				
1070.0	54.5	1.251				
1075.0	54.5	1.255				
1080.0	54.4	1.261				
1085.0	54.4	1.266				
1090.0	54.3	1.271				
1095.0	54.3	1.276				
1100.0	54.3	1.281				
1105.0	54.2	1.287				
1110.0	54.2	1.292				
1115.0	54.1	1.297				
1120.0	54.1	1.302				
1125.0	54.1	1.307				
1130.0	54.0	1.312				
1135.0	54.0	1.318				
1140.0	53.9	1.323				
1145.0	53.9	1.328				
1150.0	53.9	1.334				
1155.0	53.8	1.339				
1160.0	53.8	1.344				
1165.0	53.8	1.349				
1170.0	53.7	1.354				
1175.0	53.7	1.360				
1180.0	53.6	1.365				
1185.0	53.6	1.370				
1190.0	53.6	1.376				
1195.0	53.5	1.381				
1200.0	53.5	1.386				

NORTHWEST EMC		Tissue - Equivalent Liquid		SAR 2011.02.21	
EUT:	MSL900	Work Order:	ITRM0248		
Serial Number:	SAT	Date:	08/10/2011		
Customer:	Intermec Technologies Corporation	Temperature (°C):	23.6		
Attendees:	None	Humidity:	43.5		
Project:	ITRM0227	Barometric Pres. (mb):	1017		
Tested by:	Jennifer Herrett	Power:	None	Job Site:	Cal Lab
TEST SPECIFICATIONS		Test Method			
FCC 2.1093:2011		FCC OET 65C:2001			
COMMENTS					
None					
DEVIATIONS FROM TEST STANDARD					
None					
Configuration #	None	Signature <i>Jennifer Herrett</i>			
Tissue: MSL900			Liquid Temperature (°C): 22.1		

Frequency (GHz)	Actual Values		Target Values		Deviation (%)	
	Relative Permittivity	Conductivity	Relative Permittivity	Conductivity	Relative Permittivity	Conductivity
835	56.512	1.011	55.200	0.970	-2.38	-4.24
700.0	57.7	0.887				
705.0	57.7	0.892				
710.0	57.7	0.896				
715.0	57.6	0.901				
720.0	57.6	0.906				
725.0	57.5	0.910				
730.0	57.4	0.915				
735.0	57.4	0.920				
740.0	57.3	0.924				
745.0	57.3	0.929				
750.0	57.2	0.933				
755.0	57.2	0.938				
760.0	57.1	0.943				
765.0	57.1	0.947				
770.0	57.0	0.952				
775.0	57.0	0.957				
780.0	56.9	0.961				
785.0	56.9	0.966				
790.0	56.8	0.970				
795.0	56.8	0.975				
800.0	56.7	0.979				
805.0	56.7	0.983				
810.0	56.7	0.988				
815.0	56.6	0.992				
820.0	56.6	0.996				
825.0	56.6	1.001				
830.0	56.5	1.006				
835.0	56.5	1.011				
840.0	56.5	1.017				
845.0	56.4	1.022				
850.0	56.4	1.028				
855.0	56.3	1.033				
860.0	56.3	1.038				
865.0	56.2	1.043				
870.0	56.2	1.048				
875.0	56.2	1.053				
880.0	56.1	1.058				
885.0	56.1	1.062				
890.0	56.0	1.067				
895.0	56.0	1.072				
900.0	55.9	1.077				
905.0	55.9	1.083				
910.0	55.8	1.087				
915.0	55.8	1.092				
920.0	55.7	1.097				
925.0	55.7	1.103				
930.0	55.6	1.107				
935.0	55.6	1.112				
940.0	55.6	1.116				
945.0	55.5	1.122				
950.0	55.5	1.126				
955.0	55.4	1.131				
960.0	55.4	1.136				
965.0	55.3	1.140				
970.0	55.3	1.145				
975.0	55.3	1.150				
980.0	55.2	1.155				
985.0	55.2	1.160				
990.0	55.2	1.165				
995.0	55.1	1.170				
1000.0	55.1	1.175				
1005.0	55.0	1.180				
1010.0	55.0	1.186				
1015.0	54.9	1.190				
1020.0	54.9	1.196				
1025.0	54.9	1.201				
1030.0	54.8	1.206				
1035.0	54.8	1.211				
1040.0	54.8	1.217				
1045.0	54.7	1.223				
1050.0	54.7	1.229				
1055.0	54.6	1.234				
1060.0	54.6	1.240				
1065.0	54.6	1.245				
1070.0	54.5	1.251				
1075.0	54.5	1.255				
1080.0	54.4	1.261				
1085.0	54.4	1.266				
1090.0	54.3	1.271				
1095.0	54.3	1.276				
1100.0	54.3	1.281				
1105.0	54.2	1.287				
1110.0	54.2	1.292				
1115.0	54.1	1.297				
1120.0	54.1	1.302				
1125.0	54.1	1.307				
1130.0	54.0	1.312				
1135.0	54.0	1.318				
1140.0	53.9	1.323				
1145.0	53.9	1.328				
1150.0	53.9	1.334				
1155.0	53.8	1.339				
1160.0	53.8	1.344				
1165.0	53.8	1.349				
1170.0	53.7	1.354				
1175.0	53.7	1.360				
1180.0	53.6	1.365				
1185.0	53.6	1.370				
1190.0	53.6	1.376				
1195.0	53.5	1.381				
1200.0	53.5	1.386				

EMC**Tissue - Equivalent Liquid**

EUT: HSL1900	Work Order: ITRM0248
Serial Number: SAN	Date: 08/10/2011
Customer: Intermec Technologies Corporation	Temperature (°C): 23.6
Attendees: None	Humidity: 43.5
Project: ITRM0227	Barometric Pres. (mb): 1017
Tested by: Jennifer Herrett	Power: None
Job Site: Cal Lab	
TEST SPECIFICATIONS	
FCC 2.1093:2011	Test Method: FCC OET 65C:2001
COMMENTS	
None	
DEVIATIONS FROM TEST STANDARD	
None	
Configuration #	None
Signature <i>Jennifer Herrett</i>	
Tissue: HSL1900	
Liquid Temperature (°C): 22.1	

Frequency (GHz)	Actual Values		Target Values		Deviation (%)	
	Relative Permittivity	Conductivity	Relative Permittivity	Conductivity	Relative Permittivity	Conductivity
1900	39.865	1.397	40.000	1.400	0.34	0.20
1600.0	41.0	1.100				
1612.5	41.0	1.112				
1625.0	40.9	1.123				
1637.5	40.9	1.136				
1650.0	40.8	1.148				
1662.5	40.8	1.160				
1675.0	40.7	1.171				
1687.5	40.7	1.183				
1700.0	40.6	1.195				
1712.5	40.6	1.205				
1725.0	40.5	1.216				
1737.5	40.5	1.227				
1750.0	40.4	1.238				
1762.5	40.4	1.249				
1775.0	40.3	1.262				
1787.5	40.3	1.275				
1800.0	40.3	1.289				
1812.5	40.2	1.302				
1825.0	40.2	1.317				
1837.5	40.1	1.331				
1850.0	40.1	1.345				
1862.5	40.0	1.358				
1875.0	40.0	1.371				
1887.5	39.9	1.384				
1900.0	39.9	1.397				
1912.5	39.8	1.410				
1925.0	39.8	1.423				
1937.5	39.7	1.436				
1950.0	39.7	1.449				
1962.5	39.6	1.462				
1975.0	39.6	1.476				
1987.5	39.5	1.489				
2000.0	39.5	1.502				

EMC**Tissue - Equivalent Liquid**

EUT:	HSL1900	Work Order:	ITRM0248
Serial Number:	SAN	Date:	08/12/2011
Customer:	Intermec Technologies Corporation	Temperature (°C):	22.4
Attendees:	None	Humidity:	40.4
Project:	ITRM0227	Barometric Pres. (mb):	1016.7
Tested by:	Jennifer Herrett	Power:	None
TEST SPECIFICATIONS		Test Method	
FCC 2.1093:2011		FCC OET 65C:2001	
COMMENTS			
None			
DEVIATIONS FROM TEST STANDARD			
None			
Configuration #	None	Signature <i>Jennifer Herrett</i>	
Tissue: HSL1900		Liquid Temperature (°C): 22	

Frequency (GHz)	Actual Values		Target Values		Deviation (%)	
	Relative Permittivity	Conductivity	Relative Permittivity	Conductivity	Relative Permittivity	Conductivity
1900	39.782	1.387	40.000	1.400	0.54	0.96

1600.0	40.9	1.091
1612.5	40.9	1.102
1625.0	40.8	1.114
1637.5	40.8	1.126
1650.0	40.7	1.138
1662.5	40.7	1.151
1675.0	40.6	1.163
1687.5	40.5	1.174
1700.0	40.5	1.185
1712.5	40.4	1.197
1725.0	40.4	1.208
1737.5	40.4	1.218
1750.0	40.3	1.229
1762.5	40.3	1.240
1775.0	40.3	1.253
1787.5	40.2	1.266
1800.0	40.2	1.279
1812.5	40.1	1.293
1825.0	40.1	1.307
1837.5	40.0	1.320
1850.0	40.0	1.335
1862.5	39.9	1.348
1875.0	39.9	1.361
1887.5	39.8	1.374
1900.0	39.8	1.387
1912.5	39.7	1.399
1925.0	39.7	1.412
1937.5	39.6	1.424
1950.0	39.6	1.437
1962.5	39.5	1.450
1975.0	39.5	1.463
1987.5	39.4	1.476
2000.0	39.4	1.490

EMC**Tissue - Equivalent Liquid**

EUT: HSL1900	Work Order: ITRM0248
Serial Number: SAN	Date: 08/15/2011
Customer: Intermec Technologies Corporation	Temperature (°C): 23.3
Attendees: None	Humidity: 47.9
Project: ITRM0227	Barometric Pres. (mb): 1017.4
Tested by: Jennifer Herrett	Power: None
Job Site: Cal Lab	
TEST SPECIFICATIONS	
FCC 2.1093:2011	Test Method: FCC OET 65C:2001
COMMENTS	
None	
DEVIATIONS FROM TEST STANDARD	
None	
Configuration #	None
 <i>Signature</i>	
Tissue: HSL1900 Liquid Temperature (°C): 22.8	

Frequency (GHz)	Actual Values		Target Values		Deviation (%)	
	Relative Permittivity	Conductivity	Relative Permittivity	Conductivity	Relative Permittivity	Conductivity
1900	40.326	1.446	40.000	1.400	-0.82	-3.26
1600.0	41.7	1.132				
1612.5	41.6	1.145				
1625.0	41.6	1.159				
1637.5	41.5	1.173				
1650.0	41.5	1.186				
1662.5	41.4	1.199				
1675.0	41.3	1.211				
1687.5	41.3	1.224				
1700.0	41.2	1.235				
1712.5	41.1	1.247				
1725.0	41.1	1.259				
1737.5	41.0	1.271				
1750.0	41.0	1.283				
1762.5	40.9	1.296				
1775.0	40.9	1.309				
1787.5	40.8	1.322				
1800.0	40.8	1.336				
1812.5	40.7	1.351				
1825.0	40.7	1.365				
1837.5	40.6	1.379				
1850.0	40.6	1.394				
1862.5	40.5	1.407				
1875.0	40.5	1.420				
1887.5	40.4	1.433				
1900.0	40.3	1.446				
1912.5	40.3	1.459				
1925.0	40.2	1.472				
1937.5	40.1	1.486				
1950.0	40.1	1.498				
1962.5	40.0	1.514				
1975.0	40.0	1.527				
1987.5	39.9	1.541				
2000.0	39.9	1.555				

EMC**Tissue - Equivalent Liquid**

EUT: MSL1900	Work Order: ITRM0248
Serial Number: SAO	Date: 08/15/2011
Customer: Intermec Technologies Corporation	Temperature (°C): 23.3
Attendees: None	Humidity: 47.9
Project: ITRM0227	Barometric Pres. (mb): 1017.4
Tested by: Jennifer Herrett	Power: None
Job Site: Cal Lab	
TEST SPECIFICATIONS	
FCC 2.1093:2011	Test Method: FCC OET 65C:2001
COMMENTS	
None	
DEVIATIONS FROM TEST STANDARD	
None	
Configuration #	None
<i>Signature</i> 	
Tissue: MSL1900	
Liquid Temperature (°C): 22.8	

Frequency (GHz)	Actual Values		Target Values		Deviation (%)	
	Relative Permittivity	Conductivity	Relative Permittivity	Conductivity	Relative Permittivity	Conductivity
1900	52.907	1.508	53.300	1.520	0.74	0.78

1600.0	53.9	1.169
1612.5	53.9	1.184
1625.0	53.9	1.199
1637.5	53.8	1.213
1650.0	53.8	1.228
1662.5	53.7	1.241
1675.0	53.7	1.255
1687.5	53.6	1.268
1700.0	53.6	1.279
1712.5	53.5	1.292
1725.0	53.5	1.304
1737.5	53.4	1.316
1750.0	53.4	1.329
1762.5	53.4	1.342
1775.0	53.3	1.356
1787.5	53.3	1.370
1800.0	53.3	1.385
1812.5	53.2	1.401
1825.0	53.2	1.417
1837.5	53.2	1.433
1850.0	53.1	1.449
1862.5	53.1	1.464
1875.0	53.0	1.479
1887.5	53.0	1.494
1900.0	52.9	1.508
1912.5	52.9	1.522
1925.0	52.8	1.537
1937.5	52.8	1.551
1950.0	52.7	1.566
1962.5	52.7	1.581
1975.0	52.6	1.595
1987.5	52.6	1.611
2000.0	52.5	1.626

NORTHWEST EMC		Tissue - Equivalent Liquid		SAR 2011.02.21	
EUT:	HSL900	Work Order:	ITRM0248		
Serial Number:	SAS	Date:	08/16/2011		
Customer:	Intermec Technologies Corporation	Temperature (°C):	23.5		
Attendees:	None	Humidity:	43.5		
Project:	ITRM0227	Barometric Pres. (mb):	1018.5		
Tested by:	Jennifer Herrett	Power:	None	Job Site:	Cal Lab
TEST SPECIFICATIONS		Test Method			
FCC 2.1093:2011		FCC OET 65C:2001			
COMMENTS					
None					
DEVIATIONS FROM TEST STANDARD					
None					
Configuration #	None	Signature <i>Jennifer Herrett</i>			
Tissue: HSL900			Liquid Temperature (°C): 22.5		

Frequency (GHz)	Actual Values		Target Values		Deviation (%)	
	Relative Permittivity	Conductivity	Relative Permittivity	Conductivity	Relative Permittivity	Conductivity
835	39.922	0.858	41.500	0.900	3.80	4.64
700.0	41.7	0.735				
705.0	41.6	0.740				
710.0	41.5	0.745				
715.0	41.5	0.749				
720.0	41.4	0.753				
725.0	41.3	0.758				
730.0	41.3	0.763				
735.0	41.2	0.768				
740.0	41.1	0.772				
745.0	41.0	0.777				
750.0	41.0	0.781				
755.0	40.9	0.786				
760.0	40.9	0.790				
765.0	40.8	0.795				
770.0	40.7	0.800				
775.0	40.7	0.804				
780.0	40.6	0.809				
785.0	40.5	0.813				
790.0	40.5	0.818				
795.0	40.4	0.823				
800.0	40.3	0.827				
805.0	40.3	0.831				
810.0	40.2	0.836				
815.0	40.2	0.840				
820.0	40.1	0.845				
825.0	40.0	0.849				
830.0	40.0	0.854				
835.0	39.9	0.858				
840.0	39.9	0.863				
845.0	39.8	0.867				
850.0	39.7	0.872				
855.0	39.7	0.877				
860.0	39.6	0.881				
865.0	39.6	0.885				
870.0	39.5	0.890				
875.0	39.5	0.895				
880.0	39.4	0.899				
885.0	39.3	0.903				
890.0	39.3	0.908				
895.0	39.2	0.912				
900.0	39.2	0.917				
905.0	39.1	0.921				
910.0	39.1	0.926				
915.0	39.0	0.930				
920.0	38.9	0.935				
925.0	38.9	0.940				
930.0	38.8	0.944				
935.0	38.8	0.948				
940.0	38.7	0.953				
945.0	38.7	0.957				
950.0	38.6	0.961				
955.0	38.5	0.966				
960.0	38.5	0.971				
965.0	38.4	0.975				
970.0	38.4	0.979				
975.0	38.3	0.984				
980.0	38.3	0.988				
985.0	38.2	0.993				
990.0	38.2	0.997				
995.0	38.1	1.002				
1000.0	38.1	1.006				
1005.0	38.0	1.011				
1010.0	38.0	1.015				
1015.0	37.9	1.019				
1020.0	37.9	1.024				
1025.0	37.8	1.028				
1030.0	37.8	1.033				
1035.0	37.7	1.038				
1040.0	37.7	1.042				
1045.0	37.7	1.047				
1050.0	37.6	1.052				
1055.0	37.6	1.056				
1060.0	37.5	1.061				
1065.0	37.5	1.066				
1070.0	37.4	1.070				
1075.0	37.4	1.075				
1080.0	37.3	1.079				
1085.0	37.3	1.084				
1090.0	37.2	1.088				
1095.0	37.2	1.093				
1100.0	37.1	1.097				
1105.0	37.1	1.102				
1110.0	37.0	1.106				
1115.0	37.0	1.110				
1120.0	36.9	1.114				
1125.0	36.9	1.119				
1130.0	36.8	1.123				
1135.0	36.8	1.127				
1140.0	36.7	1.132				
1145.0	36.7	1.136				
1150.0	36.6	1.140				
1155.0	36.6	1.145				
1160.0	36.5	1.150				
1165.0	36.5	1.154				
1170.0	36.5	1.158				
1175.0	36.4	1.163				
1180.0	36.4	1.167				
1185.0	36.3	1.171				
1190.0	36.3	1.176				
1195.0	36.2	1.180				
1200.0	36.2	1.185				

NORTHWEST EMC		Tissue - Equivalent Liquid		SAR 2011.02.21	
EUT:	HSL900	Work Order:	ITRM0248		
Serial Number:	SAS	Date:	08/18/2011		
Customer:	Intermec Technologies Corporation	Temperature (°C):	23.1		
Attendees:	None	Humidity:	43		
Project:	ITRM0227	Barometric Pres. (mb):	1022.5		
Tested by:	Jennifer Herrett	Power:	None	Job Site:	Cal Lab
TEST SPECIFICATIONS		Test Method			
FCC 2.1093:2011		FCC OET 65C:2001			
COMMENTS					
None					
DEVIATIONS FROM TEST STANDARD					
None					
Configuration #	None	Signature <i>Jennifer Herrett</i>			
Tissue: HSL900			Liquid Temperature (°C): 21.8		

Frequency (GHz)	Actual Values		Target Values		Deviation (%)	
	Relative Permittivity	Conductivity	Relative Permittivity	Conductivity	Relative Permittivity	Conductivity
835	39.546	0.856	41.500	0.900	4.71	4.86
700.0	41.3	0.734				
705.0	41.2	0.739				
710.0	41.2	0.743				
715.0	41.1	0.748				
720.0	41.0	0.752				
725.0	41.0	0.756				
730.0	40.9	0.761				
735.0	40.8	0.765				
740.0	40.8	0.770				
745.0	40.7	0.774				
750.0	40.6	0.779				
755.0	40.6	0.783				
760.0	40.5	0.787				
765.0	40.4	0.792				
770.0	40.4	0.797				
775.0	40.3	0.801				
780.0	40.2	0.806				
785.0	40.2	0.811				
790.0	40.1	0.816				
795.0	40.0	0.820				
800.0	40.0	0.824				
805.0	39.9	0.829				
810.0	39.8	0.834				
815.0	39.8	0.838				
820.0	39.7	0.843				
825.0	39.7	0.847				
830.0	39.6	0.852				
835.0	39.5	0.856				
840.0	39.5	0.861				
845.0	39.4	0.866				
850.0	39.4	0.870				
855.0	39.3	0.875				
860.0	39.3	0.879				
865.0	39.2	0.883				
870.0	39.2	0.888				
875.0	39.1	0.892				
880.0	39.1	0.896				
885.0	39.0	0.901				
890.0	38.9	0.905				
895.0	38.9	0.909				
900.0	38.8	0.914				
905.0	38.8	0.918				
910.0	38.7	0.922				
915.0	38.6	0.927				
920.0	38.6	0.931				
925.0	38.5	0.935				
930.0	38.5	0.940				
935.0	38.4	0.944				
940.0	38.3	0.949				
945.0	38.3	0.953				
950.0	38.2	0.958				
955.0	38.2	0.962				
960.0	38.1	0.967				
965.0	38.1	0.971				
970.0	38.0	0.976				
975.0	37.9	0.980				
980.0	37.9	0.984				
985.0	37.8	0.989				
990.0	37.8	0.993				
995.0	37.7	0.997				
1000.0	37.7	1.002				
1005.0	37.7	1.006				
1010.0	37.6	1.011				
1015.0	37.6	1.015				
1020.0	37.5	1.019				
1025.0	37.5	1.024				
1030.0	37.4	1.028				
1035.0	37.4	1.033				
1040.0	37.3	1.037				
1045.0	37.3	1.041				
1050.0	37.2	1.046				
1055.0	37.2	1.050				
1060.0	37.1	1.054				
1065.0	37.1	1.059				
1070.0	37.0	1.063				
1075.0	37.0	1.068				
1080.0	36.9	1.072				
1085.0	36.9	1.077				
1090.0	36.8	1.081				
1095.0	36.8	1.086				
1100.0	36.7	1.090				
1105.0	36.7	1.095				
1110.0	36.6	1.099				
1115.0	36.6	1.104				
1120.0	36.5	1.108				
1125.0	36.5	1.112				
1130.0	36.4	1.117				
1135.0	36.4	1.121				
1140.0	36.3	1.125				
1145.0	36.3	1.130				
1150.0	36.2	1.134				
1155.0	36.2	1.138				
1160.0	36.1	1.142				
1165.0	36.1	1.147				
1170.0	36.0	1.151				
1175.0	36.0	1.156				
1180.0	35.9	1.160				
1185.0	35.9	1.164				
1190.0	35.8	1.169				
1195.0	35.8	1.173				
1200.0	35.8	1.177				

EMC**Tissue - Equivalent Liquid**

EUT: MSL1900	Work Order: ITRM0248
Serial Number: SAO	Date: 08/19/2011
Customer: Intermec Technologies Corporation	Temperature (°C): 23.1
Attendees: None	Humidity: 44.1
Project: ITRM0227	Barometric Pres. (mb): 1017.9
Tested by: Jennifer Herrett	Power: None
Job Site: Cal Lab	
TEST SPECIFICATIONS	
FCC 2.1093:2011	Test Method FCC OET 65C:2001
COMMENTS	
None	
DEVIATIONS FROM TEST STANDARD	
None	
Configuration #	None
Signature <i>Jennifer Herrett</i>	
Tissue: MSL1900	
Liquid Temperature (°C): 22.8	

Frequency (GHz)	Actual Values		Target Values		Deviation (%)	
	Relative Permittivity	Conductivity	Relative Permittivity	Conductivity	Relative Permittivity	Conductivity
1900	52.609	1.504	53.300	1.520	1.30	1.08

1600.0	53.7	1.178
1612.5	53.6	1.191
1625.0	53.6	1.204
1637.5	53.6	1.218
1650.0	53.5	1.232
1662.5	53.5	1.246
1675.0	53.4	1.260
1687.5	53.4	1.273
1700.0	53.3	1.286
1712.5	53.3	1.298
1725.0	53.2	1.311
1737.5	53.2	1.322
1750.0	53.1	1.334
1762.5	53.1	1.348
1775.0	53.1	1.361
1787.5	53.0	1.375
1800.0	53.0	1.391
1812.5	52.9	1.405
1825.0	52.9	1.420
1837.5	52.8	1.435
1850.0	52.8	1.449
1862.5	52.7	1.463
1875.0	52.7	1.477
1887.5	52.6	1.490
1900.0	52.6	1.504
1912.5	52.6	1.517
1925.0	52.5	1.531
1937.5	52.5	1.546
1950.0	52.5	1.560
1962.5	52.4	1.575
1975.0	52.4	1.590
1987.5	52.4	1.605
2000.0	52.3	1.620

EMC**Tissue - Equivalent Liquid**

EUT: HSL1750	Work Order: ITRM0248
Serial Number: SAP	Date: 08/20/2011
Customer: Intermec Technologies Corporation	Temperature (°C): 23.6
Attendees: None	Humidity: 45.5
Project: ITRM0227	Barometric Pres. (mb): 1009.7
Tested by: Jennifer Herrett	Power: None
Job Site: Cal Lab	
TEST SPECIFICATIONS	
FCC 2.1093:2011	Test Method
	FCC OET 65C:2001
COMMENTS	
None	
DEVIATIONS FROM TEST STANDARD	
None	
Configuration #	None
<i>Signature</i> 	
Tissue: HSL1750 Liquid Temperature (°C): 21.5	

Frequency (GHz)	Actual Values		Target Values		Deviation (%)	
	Relative Permittivity	Conductivity	Relative Permittivity	Conductivity	Relative Permittivity	Conductivity
1800	40.532	1.432	40.000	1.400	-1.33	-2.30
1400.0	42.4	1.038				
1425.0	42.3	1.062				
1450.0	42.2	1.085				
1475.0	42.0	1.109				
1500.0	41.9	1.133				
1525.0	41.8	1.157				
1550.0	41.7	1.182				
1575.0	41.6	1.206				
1600.0	41.5	1.230				
1625.0	41.4	1.254				
1650.0	41.3	1.280				
1675.0	41.1	1.306				
1700.0	41.0	1.333				
1725.0	40.9	1.359				
1750.0	40.8	1.384				
1775.0	40.6	1.408				
1800.0	40.5	1.432				
1825.0	40.4	1.458				
1850.0	40.3	1.485				
1875.0	40.2	1.513				
1900.0	40.1	1.540				

EMC**Tissue - Equivalent Liquid**

EUT: MSL1750	Work Order: ITRM0248
Serial Number: SAQ	Date: 08/22/2011
Customer: Intermec Technologies Corporation	Temperature (°C): 21.2
Attendees: None	Humidity: 55.5
Project: ITRM0227	Barometric Pres. (mb): 1016.5
Tested by: Jennifer Herrett	Power: None
Job Site: Cal Lab	
TEST SPECIFICATIONS	
FCC 2.1093:2011	Test Method
	FCC OET 65C:2001
COMMENTS	
None	
DEVIATIONS FROM TEST STANDARD	
None	
Configuration #	None
Signature <i>Jennifer Herrett</i>	
Tissue: MSL1750	
Liquid Temperature (°C): 22.4	

Frequency (GHz)	Actual Values		Target Values		Deviation (%)	
	Relative Permittivity	Conductivity	Relative Permittivity	Conductivity	Relative Permittivity	Conductivity
1800	52.788	1.503	53.300	1.520	0.96	1.13
1400.0	54.2	1.089				
1425.0	54.1	1.115				
1450.0	54.0	1.139				
1475.0	53.9	1.162				
1500.0	53.8	1.186				
1525.0	53.7	1.211				
1550.0	53.6	1.239				
1575.0	53.5	1.268				
1600.0	53.4	1.291				
1625.0	53.4	1.315				
1650.0	53.3	1.341				
1675.0	53.2	1.368				
1700.0	53.1	1.398				
1725.0	53.0	1.427				
1750.0	52.9	1.454				
1775.0	52.9	1.479				
1800.0	52.8	1.503				
1825.0	52.7	1.529				
1850.0	52.6	1.557				
1875.0	52.5	1.588				
1900.0	52.5	1.617				

EMC**Tissue - Equivalent Liquid**

EUT: HSL1900	Work Order: ITRM0248
Serial Number: SAN	Date: 08/23/2011
Customer: Intermec Technologies Corporation	Temperature (°C): 23.2
Attendees: None	Humidity: 49.4
Project: ITRM0227	Barometric Pres. (mb): 1017.6
Tested by: Jennifer Herrett	Power: None
Job Site: Cal Lab	
TEST SPECIFICATIONS	
FCC 2.1093:2011	Test Method: FCC OET 65C:2001
COMMENTS	
None	
DEVIATIONS FROM TEST STANDARD	
None	
Configuration #	None
 Signature	
Tissue: HSL1900 Liquid Temperature (°C): 22.1	

Frequency (GHz)	Actual Values		Target Values		Deviation (%)	
	Relative Permittivity	Conductivity	Relative Permittivity	Conductivity	Relative Permittivity	Conductivity
1900	39.197	1.420	40.000	1.400	2.01	-1.41
1600.0	40.5	1.115				
1612.5	40.5	1.127				
1625.0	40.4	1.139				
1637.5	40.4	1.151				
1650.0	40.3	1.163				
1662.5	40.3	1.176				
1675.0	40.2	1.189				
1687.5	40.1	1.201				
1700.0	40.1	1.215				
1712.5	40.0	1.228				
1725.0	40.0	1.241				
1737.5	39.9	1.253				
1750.0	39.8	1.265				
1762.5	39.8	1.277				
1775.0	39.7	1.290				
1787.5	39.7	1.302				
1800.0	39.6	1.315				
1812.5	39.6	1.328				
1825.0	39.5	1.341				
1837.5	39.5	1.355				
1850.0	39.4	1.368				
1862.5	39.4	1.381				
1875.0	39.3	1.394				
1887.5	39.3	1.408				
1900.0	39.2	1.420				
1912.5	39.1	1.433				
1925.0	39.1	1.445				
1937.5	39.0	1.458				
1950.0	39.0	1.471				
1962.5	38.9	1.484				
1975.0	38.9	1.497				
1987.5	38.8	1.511				
2000.0	38.8	1.524				

Requirement

Per IEEE 1528, Section 8.2.1, "System checks are performed prior to compliance tests and the results must always be within $\pm 10\%$ of the target value corresponding to the test frequency, liquid, and the source used. The target values are 1 g or 10 g averaged SAR values measured on systems having current system validation and calibration status, and using the system check setup as shown in Figure 14. These target values should be determined using a standard source."

Test Description

Within 24 hours of a measurement, Northwest EMC used the system validation kit (calibrated reference dipole) to test whether the system was operating within its specifications. The validation was performed in the indicated bands by making SAR measurements of the reference dipole with the phantom filled with the tissue-equivalent liquid. First, a signal generator and power amplifier were used to produce a 100mW level as measured with a power meter at the antenna terminals of the dipole. Then, the reference dipole was positioned below the bottom of the phantom and centered with its axis parallel to the longest side of the phantom. A low loss and low relative permittivity spacer was used to establish the correct distance between the center axis of the reference dipole and the liquid.

For the reference dipoles, the spacing distance s is given by:

$$s = 15\text{mm}, \pm 0.2\text{mm for } 300\text{MHz} \leq f \leq 1000 \text{ MHz:}$$

$$s = 10\text{mm}, \pm 0.2\text{mm for } 1000\text{MHz} \leq f \leq 6000\text{MHz}$$

The measured 1 g and 10 g spatial average SAR values were normalized to a 1W dipole input power for comparison to the calibration data. The results are summarized in the attached table. The deviation is less than 10% in all cases, indicating that the system performance check was within tolerance.

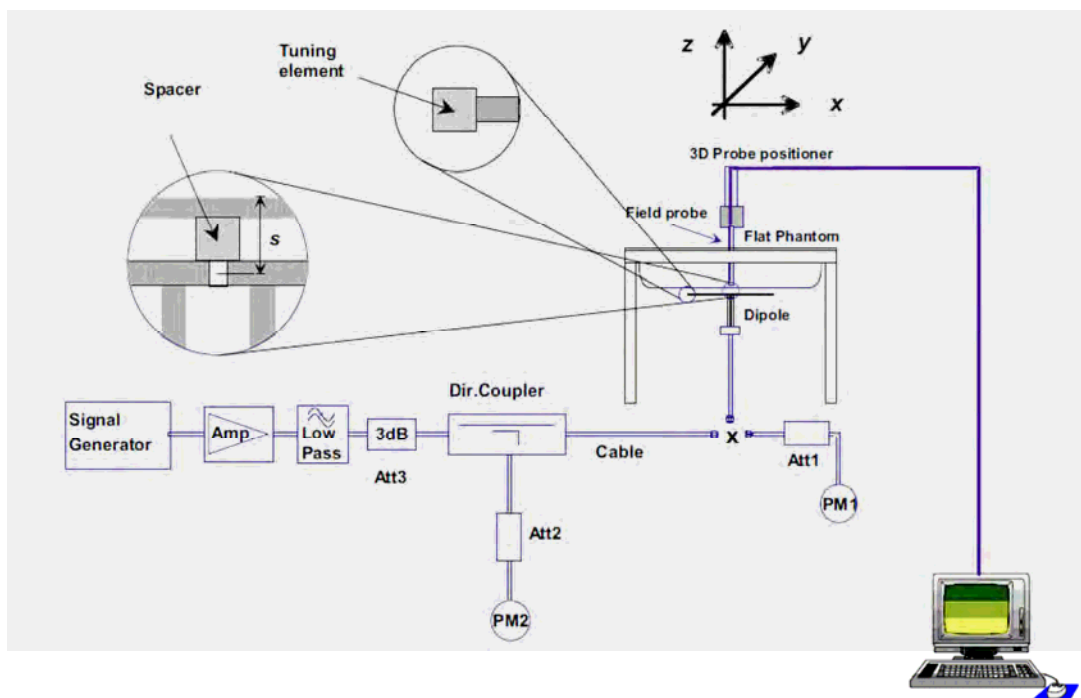

NORTHWEST EMC		System Verification		SAR 2011.02.07
EUT: System Verifications				Work Order: ITRM0248
Serial Number: Various				Date: See Data Sheets
Customer: Intermec Technologies Corporation				Temperature: See Data Sheets
Attendees: None				Humidity: See Data Sheets
Project: ITRM0227				Barometric Pres.: See Data Sheets
Tested by: Jennifer Herrett				Job Site: EV08
TEST SPECIFICATIONS		Test Method		
FCC 2.1093:2011		FCC OET 65C:2001 IEEE Std 1528:2003 FCC KDB 447498 D01 v04 FCC KDB 941225 D01 v02, and D03 FCC KDB 648474 D01 V01r05		
Health Safety Code 6:2009		RSS-102, Issue 4:2010		
COMMENTS				
None				
DEVIATIONS FROM TEST STANDARD				
No Deviations				
Configuration:	N/A	Signature <i>Jennifer Herrett</i>		

Date	Liquid part number and frequency	Conducted Power into the Dipole (dBm)	Correction Factor	1g Measured	10g Measured	1g Normalized to 1W	10g Normalized to 1W	Target 1g (Normalized to 1W) - Get from Dipole cal cert	Target 10g (Normalized to 1W) - Get from Dipole cal cert	% difference 1g	% difference 10 g	Comments
8/9/2011	MSL900 835MHz	20.00	10.00	0.99	0.65	9.89	6.54	9.93	6.51	-0.40	0.46	
8/18/2011	HSL900 835MHz	20.03	9.93	0.97	0.64	9.58	6.31	9.64	6.29	-0.59	0.26	
8/19/2011	MSL1900 1900MHz	20.04	9.91	4.05	2.13	40.13	21.10	39.90	21.00	0.57	0.50	
8/22/2011	HSL1750 1750MHz	19.98	10.05	3.62	1.92	36.37	19.29	37.20	19.60	-2.24	-1.59	
8/23/2011	MSL1750 1750MHz	19.94	10.14	3.54	1.90	35.89	19.26	38.20	20.30	-6.04	-5.10	
8/23/2011	HSL1900 1900MHz	20.00	10.00	4.16	2.14	41.60	21.40	40.20	20.90	3.48	2.39	

Room Temperature (°C):	24.1	Humidity (%):	47.8	Test Date:	08/09/11
Liquid Temperature (°C):	22.3	Barometric Pressure (mb):	1018.6	Tested by:	Jennifer Herrett

System Verifications_835M 8-9-11

DUT: Dipole 835 MHz D835V2; Type: D835V2; Serial: D835V2 - SN: 4d108

Communication System: CW; Frequency: 835 MHz

Medium parameters used: $\sigma = 1.0111$ mho/m, $\epsilon_r = 56.5118$; $\rho = 1000$ kg/m³, Medium parameters used: $f = 835$ MHz; $\sigma = 1.011$ mho/m; $\epsilon_r = 56.512$; $\rho = 1000$ kg/m³

Phantom section: Flat Section

Measurement Standard: DASYS (IEEE/IEC/ANSI C63.19-2007)

DASY5 Configuration:

Probe: ES3DV3 - SN3246; ConvF(6.1, 6.1, 6.1); Calibrated: 11/11/2010

Sensor-Surface: 0mm (Fix Surface), Sensor-Surface: 3mm (Mechanical Surface Detection)

Electronics: DAE4 Sn1237; Calibrated: 11/10/2010

Phantom: ELI 4.0; Type: QDOVA001BA; Serial: 1096

Measurement SW: DASY52, Version 52.6 (2); SEMCAD X Version 14.4.4 (2829)

Body/Body - Mid/Z Scan (1x1x21): Measurement grid: dx=20mm, dy=20mm, dz=5mm

Maximum value of Total (measured) = 28.088 V/m

Body/Body - Mid/Zoom Scan (7x7x7)/Cube 0: Measurement grid: dx=5mm, dy=5mm, dz=5mm

Reference Value = 32.492 V/m; Power Drift = -0.04 dB

Peak SAR (extrapolated) = 1.418 W/kg

SAR(1 g) = 0.989 mW/g; SAR(10 g) = 0.654 mW/g

Maximum value of SAR (measured) = 1.150 mW/g

Body/Body - Mid/Area scan (71x71x1): Measurement grid: dx=15mm, dy=15mm

Maximum value of SAR (interpolated) = 1.144 mW/g

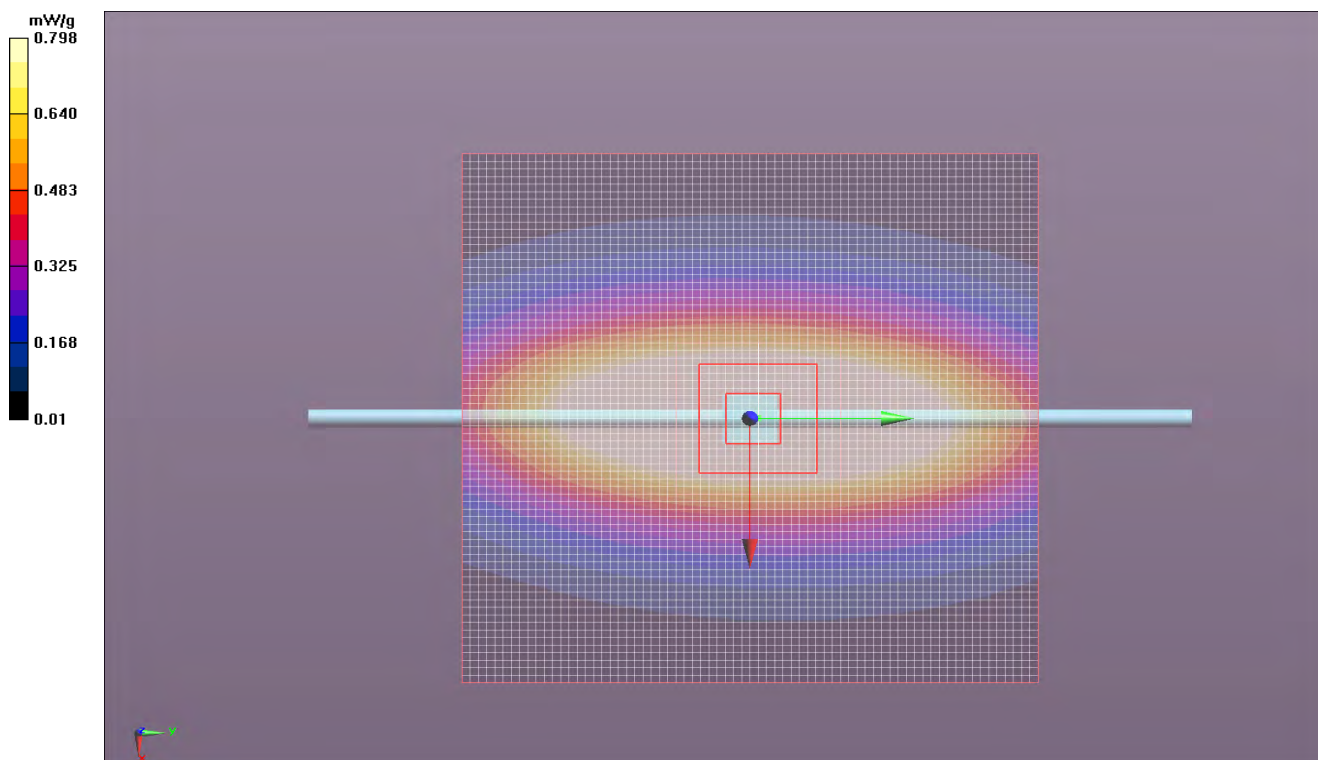

Room Temperature (°C):	23.9	Humidity (%):	45.7	Test Date:	08/18/11
Liquid Temperature (°C):	22	Barometric Pressure (mb):	1022.5	Tested by:	Jennifer Herrett

HSL900 System Check_835MHz 8-18-11

DUT: Dipole 835 MHz D835V2; Type: D835V2; Serial: D835V2 - SN:4D108

Communication System: CW; Frequency: 835 MHz

Medium parameters used: $f = 835$ MHz; $\sigma = 0.856$ mho/m; $\epsilon = 39.545$; $\rho = 1000$ kg/m³, Medium parameters used: $\sigma = 0.856266$ mho/m; $\epsilon = 39.5455$; $\rho = 1000$ kg/m³

Phantom section: Flat Section

Measurement Standard: DASYS5 (IEEE/IEC/ANSI C63.19-2007)

DASYS5 Configuration:

Probe: ES3DV3 - SN3173; ConvF(6.01, 6.01, 6.01); Calibrated: 2/23/2011

Sensor-Surface: 5mm (Mechanical Surface Detection), Sensor-Surface: 0mm (Fix Surface)

Electronics: DAE4 Sn1237; Calibrated: 11/10/2010

Phantom: SAM with CRP; Type: SAM; Serial: 1598

Measurement SW: DASYS2, Version 52.6 (2); SEMCAD X Version 14.4.4 (2829)

System Check/System Check/Area Scan (71x101x1): Measurement grid: dx=10mm, dy=10mm

Maximum value of SAR (interpolated) = 0.978 mW/g

System Check/System Check/Zoom Scan (7x7x7) (7x7x7)/Cube 0: Measurement grid: dx=5mm, dy=5mm, dz=5mm

Reference Value = 34.082 V/m; Power Drift = -0.09 dB

Peak SAR (extrapolated) = 1.432 W/kg

SAR(1 g) = 0.965 mW/g; SAR(10 g) = 0.635 mW/g

Maximum value of SAR (measured) = 0.962 mW/g

System Check/System Check/Z Scan (1x1x21): Measurement grid: dx=20mm, dy=20mm, dz=5mm

Maximum value of Total (measured) = 37.300 V/m

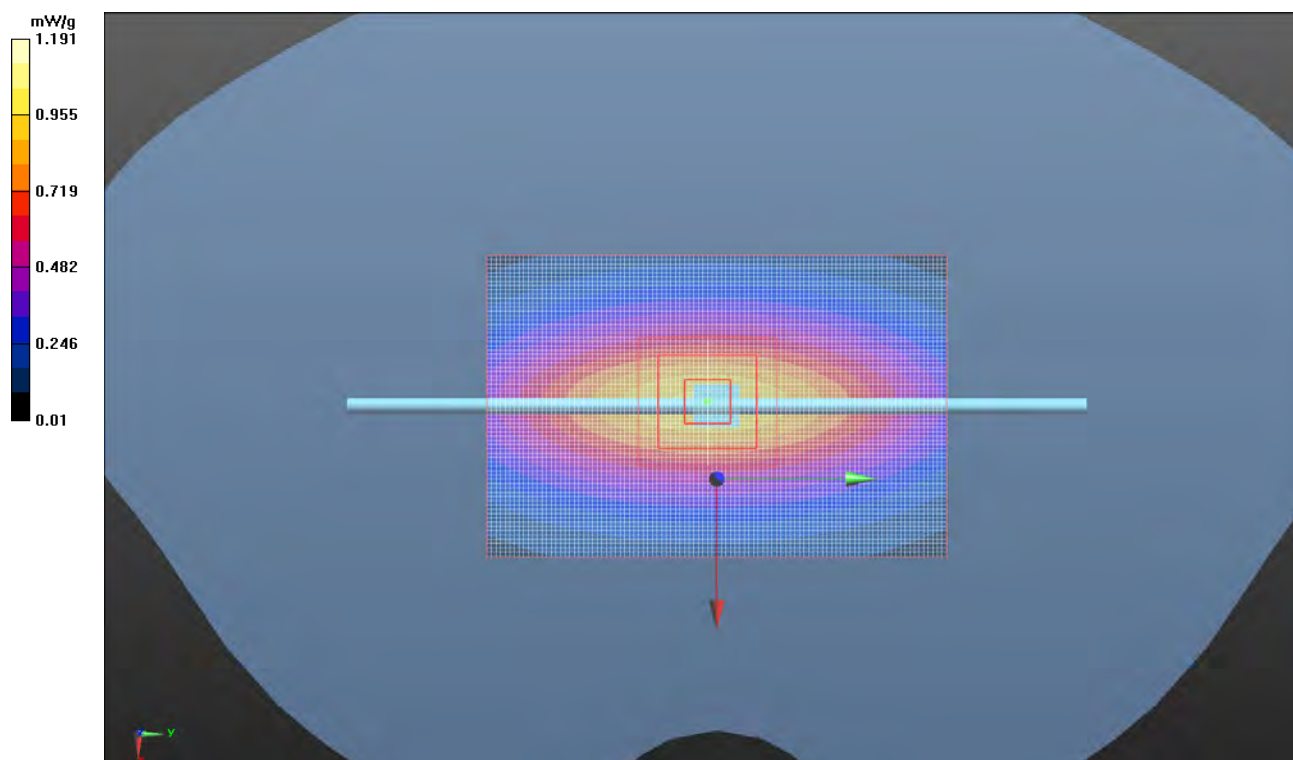

Room Temperature (°C):	25	Humidity (%):	45	Test Date:	08/19/11
Liquid Temperature (°C):	22.4	Barometric Pressure (mb):	1017.9	Tested by:	Jennifer Herrett

MSL1900 System Check_1900MHz 8-19-11

DUT: Dipole 1900 MHz D1900V2; Type: D1900V2; Serial: D1900V2 - SN:5d131

Communication System: CW; Frequency: 1900 MHz

Medium parameters used: $f = 1900$ MHz; $\sigma = 1.503$ mho/m; $\epsilon = 52.609$; $\rho = 1000$ kg/m³, Medium parameters used: $\sigma = 1.50349$ mho/m, $\epsilon = 52.6093$; $\rho = 1000$ kg/m³

Phantom section: Flat Section

Measurement Standard: DASYS5 (IEEE/IEC/ANSI C63.19-2007)

DASYS5 Configuration:

Probe: ES3DV3 - SN3173; ConvF(4.55, 4.55, 4.55); Calibrated: 2/23/2011

Sensor-Surface: 5mm (Mechanical Surface Detection), Sensor-Surface: 0mm (Fix Surface)

Electronics: DAE4 Sn1237; Calibrated: 11/10/2010

Phantom: ELI 4.0; Type: QDOVA001BA; Serial: 1096

Measurement SW: DASYS2, Version 52.6 (2); SEMCAD X Version 14.4.4 (2829)

System Check/System Check/Area Scan (51x61x1): Measurement grid: dx=10mm, dy=10mm

Maximum value of SAR (interpolated) = 4.124 mW/g

System Check/System Check/Zoom Scan (7x7x7) (7x7x7)/Cube 0: Measurement grid: dx=5mm, dy=5mm, dz=5mm

Reference Value = 52.540 V/m; Power Drift = -0.05 dB

Peak SAR (extrapolated) = 7.402 W/kg

SAR(1 g) = 4.05 mW/g; SAR(10 g) = 2.13 mW/g

Maximum value of SAR (measured) = 4.065 mW/g

System Check/System Check/Z Scan (1x1x21): Measurement grid: dx=20mm, dy=20mm, dz=5mm

Maximum value of Total (measured) = 59.348 V/m

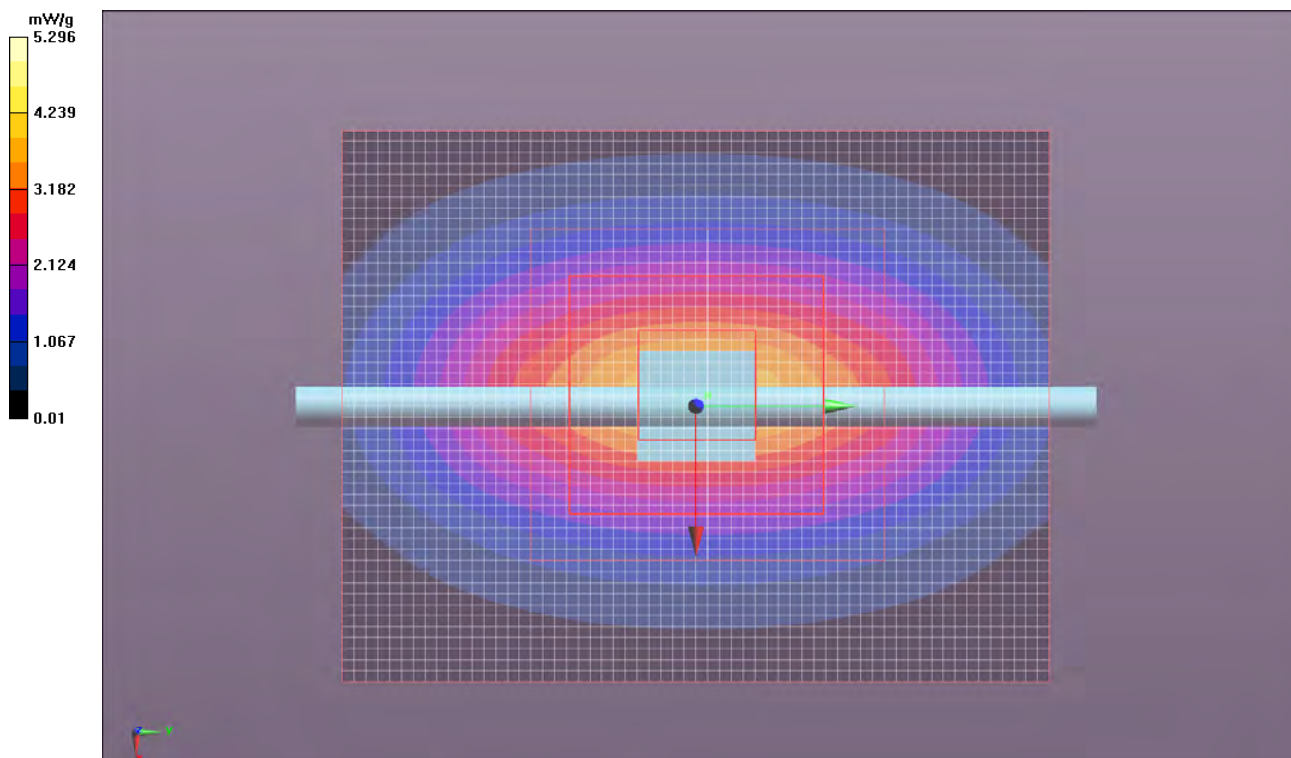

Room Temperature (°C):	24	Humidity (%):	48.2	Test Date:	08/22/11
Liquid Temperature (°C):	21.7	Barometric Pressure (mb):	1016.5	Tested by:	Jennifer Herrett

HSL1750 System Check_1750MHz 8-22-11

DUT: Dipole 1750 MHz D1750V2; Type: D1750V2; Serial: D1750V2 - SN:1040

Communication System: CW; Frequency: 1750 MHz

Medium parameters used: $f = 1750$ MHz; $\sigma = 1.384$ mho/m; $\epsilon = 40.768$; $\rho = 1000$ kg/m³, Medium parameters used: $\sigma = 1.38357$ mho/m, $\epsilon = 40.7682$; $\rho = 1000$ kg/m³

Phantom section: Flat Section

Measurement Standard: DASYS5 (IEEE/IEC/ANSI C63.19-2007)

DASYS5 Configuration:

Probe: ES3DV3 - SN3173; ConvF(5.2, 5.2, 5.2); Calibrated: 2/23/2011

Sensor-Surface: 5mm (Mechanical Surface Detection), Sensor-Surface: 0mm (Fix Surface)

Electronics: DAE4 Sn1237; Calibrated: 11/10/2010

Phantom: SAM with CRP; Type: SAM; Serial: 1598

Measurement SW: DASYS2, Version 52.6 (2); SEMCAD X Version 14.4.4 (2829)

System Check/System Check/Zoom Scan (7x7x7) (7x7x7)/Cube 0: Measurement grid: dx=5mm, dy=5mm, dz=5mm

Reference Value = 50.912 V/m; Power Drift = 0.0035 dB

Peak SAR (extrapolated) = 6.720 W/kg

SAR(1 g) = 3.62 mW/g; SAR(10 g) = 1.92 mW/g

Maximum value of SAR (measured) = 3.611 mW/g

System Check/System Check/Area Scan (51x61x1): Measurement grid: dx=10mm, dy=10mm

Maximum value of SAR (interpolated) = 3.598 mW/g

System Check/System Check/Z Scan (1x1x21): Measurement grid: dx=20mm, dy=20mm, dz=5mm

Maximum value of Total (measured) = 61.025 V/m

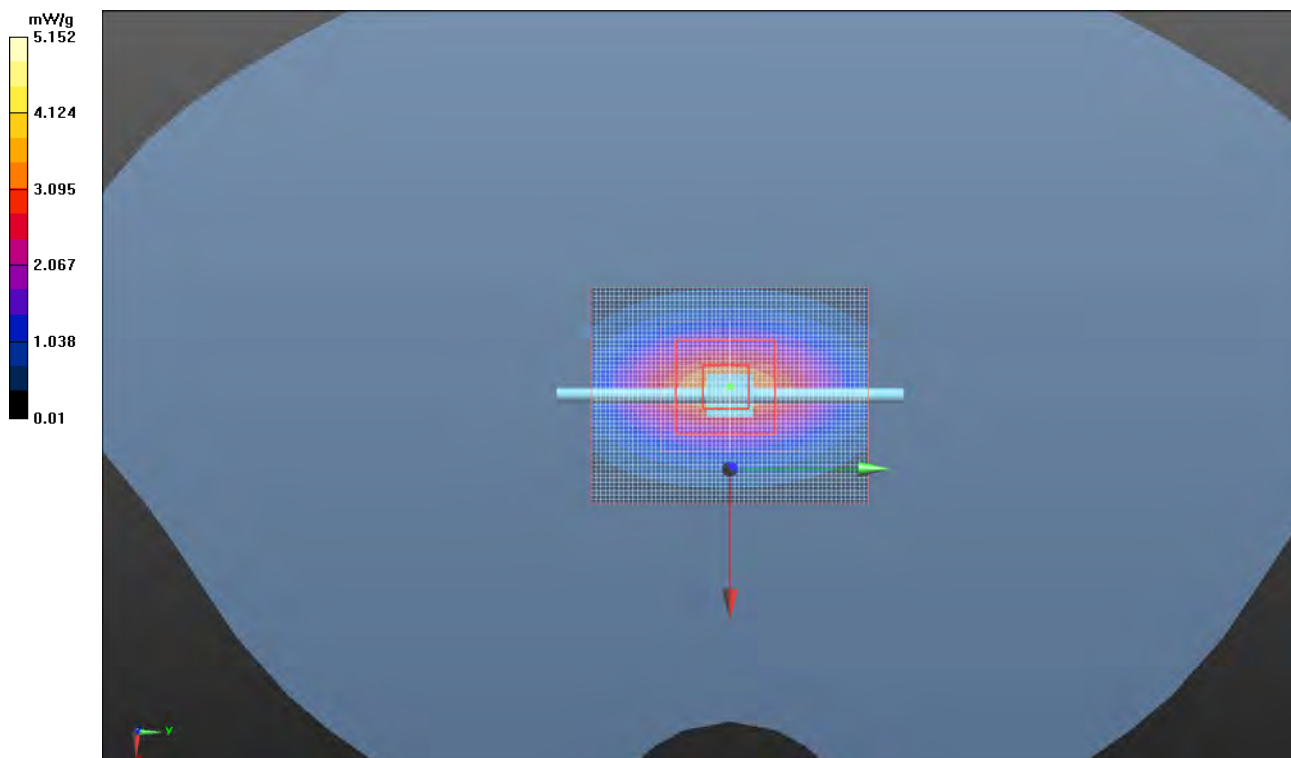

Room Temperature (°C):	24.5	Humidity (%):	49.8	Test Date:	08/23/11
Liquid Temperature (°C):	22.4	Barometric Pressure (mb):	1017.6	Tested by:	Jennifer Herrett

MSL1750 System Check_1750MHz 8-23-11

DUT: Dipole 1900 MHz D1900V2; Type: D1900V2; Serial: D1900V2 - SN:1040

Communication System: CW; Frequency: 1750 MHz

Medium parameters used: $\sigma = 1.45402$ mho/m, $\epsilon_r = 52.9303$; $\rho = 1000$ kg/m³, Medium parameters used: $f = 1750$ MHz; $\sigma = 1.454$ mho/m; $\epsilon_r = 52.93$; $\rho = 1000$ kg/m³

Phantom section: Flat Section

Measurement Standard: DASYS5 (IEEE/IEC/ANSI C63.19-2007)

DASYS5 Configuration:

Probe: ES3DV3 - SN3173; ConvF(4.87, 4.87, 4.87); Calibrated: 2/23/2011

Sensor-Surface: 0mm (Fix Surface), Sensor-Surface: 5mm (Mechanical Surface Detection)

Electronics: DAE4 Sn1237; Calibrated: 11/10/2010

Phantom: ELI 4.0; Type: QDOVA001BA; Serial: 1096

Measurement SW: DASYS2, Version 52.6 (2); SEMCAD X Version 14.4.4 (2829)

System Check/System Check/Z Scan (1x1x21): Measurement grid: dx=20mm, dy=20mm, dz=5mm

Maximum value of Total (measured) = 48.930 V/m

System Check/System Check/Zoom Scan (7x7x7) (7x7x7)/Cube 0: Measurement grid: dx=5mm, dy=5mm, dz=5mm

Reference Value = 49.805 V/m; Power Drift = 0.02 dB

Peak SAR (extrapolated) = 6.339 W/kg

SAR(1 g) = 3.54 mW/g; SAR(10 g) = 1.9 mW/g

Maximum value of SAR (measured) = 3.554 mW/g

System Check/System Check/Area Scan (51x61x1): Measurement grid: dx=10mm, dy=10mm

Maximum value of SAR (interpolated) = 3.589 mW/g

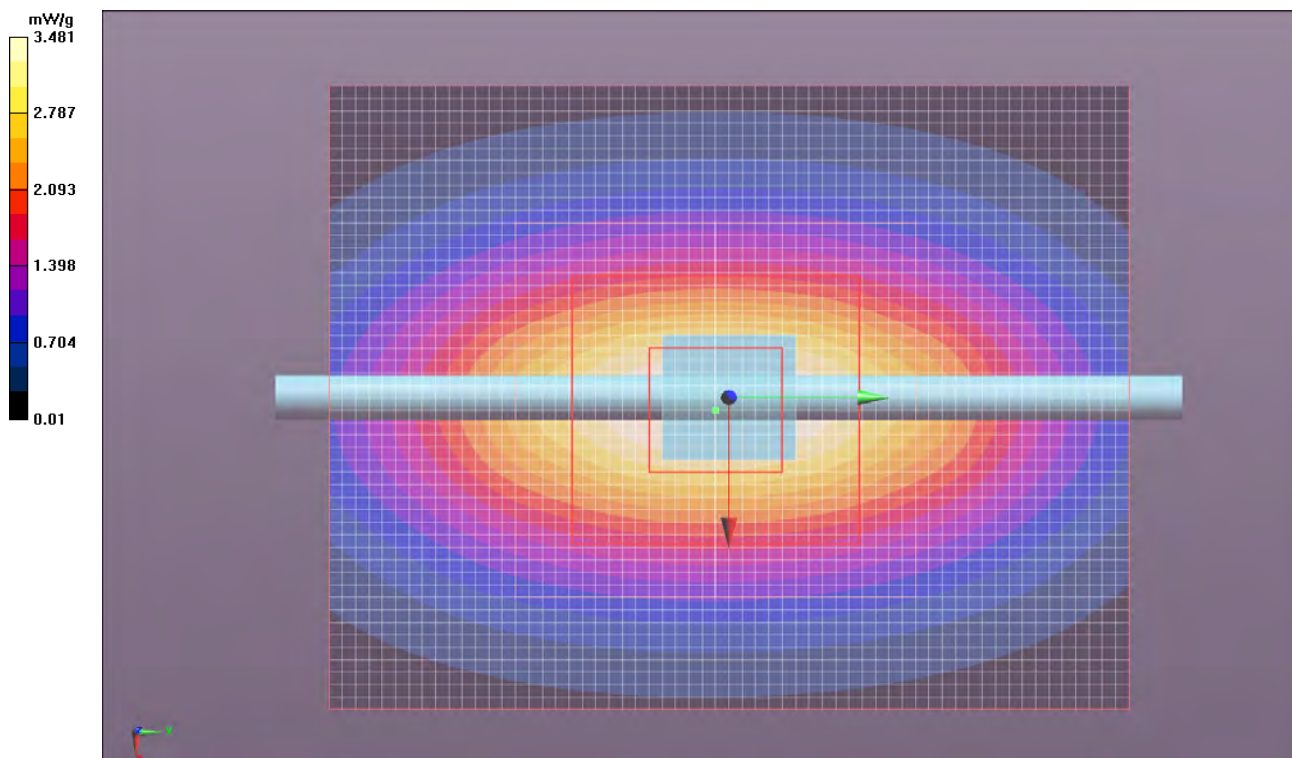

Room Temperature (°C):	24.4	Humidity (%):	47.7	Test Date:	08/23/11
Liquid Temperature (°C):	22.1	Barometric Pressure (mb):	1017.6	Tested by:	Jennifer Herrett

HSL1900 System Check_1900MHz 8-23-11

DUT: Dipole 1900 MHz D1900V2; Type: D1900V2; Serial: D1900V2 - SN:5d131

Communication System: CW; Frequency: 1900 MHz

Medium parameters used: $f = 1900$ MHz; $\sigma = 1.42$ mho/m; $\epsilon = 39.197$; $\rho = 1000$ kg/m³, Medium parameters used: $\sigma = 1.41969$ mho/m, $\epsilon = 39.1967$; $\rho = 1000$ kg/m³

Phantom section: Flat Section

Measurement Standard: DASYS (IEEE/IEC/ANSI C63.19-2007)

DASY5 Configuration:

Probe: ES3DV3 - SN3173; ConvF(4.96, 4.96, 4.96); Calibrated: 2/23/2011

Sensor-Surface: 5mm (Mechanical Surface Detection), Sensor-Surface: 0mm (Fix Surface)

Electronics: DAE4 Sn1237; Calibrated: 11/10/2010

Phantom: SAM with CRP; Type: SAM; Serial: 1598

Measurement SW: DASYS2, Version 52.6 (2); SEMCAD X Version 14.4.4 (2829)

System Check/System Check/Zoom Scan (7x7x7) (7x7x7)/Cube 0: Measurement grid: dx=5mm, dy=5mm, dz=5mm

Reference Value = 54.317 V/m; Power Drift = -0.04 dB

Peak SAR (extrapolated) = 8.001 W/kg

SAR(1 g) = 4.16 mW/g; SAR(10 g) = 2.14 mW/g

Maximum value of SAR (measured) = 4.124 mW/g

System Check/System Check/Area Scan (51x61x1): Measurement grid: dx=10mm, dy=10mm

Maximum value of SAR (interpolated) = 4.106 mW/g

System Check/System Check/Z Scan (1x1x21): Measurement grid: dx=20mm, dy=20mm, dz=5mm

Maximum value of Total (measured) = 58.571 V/m

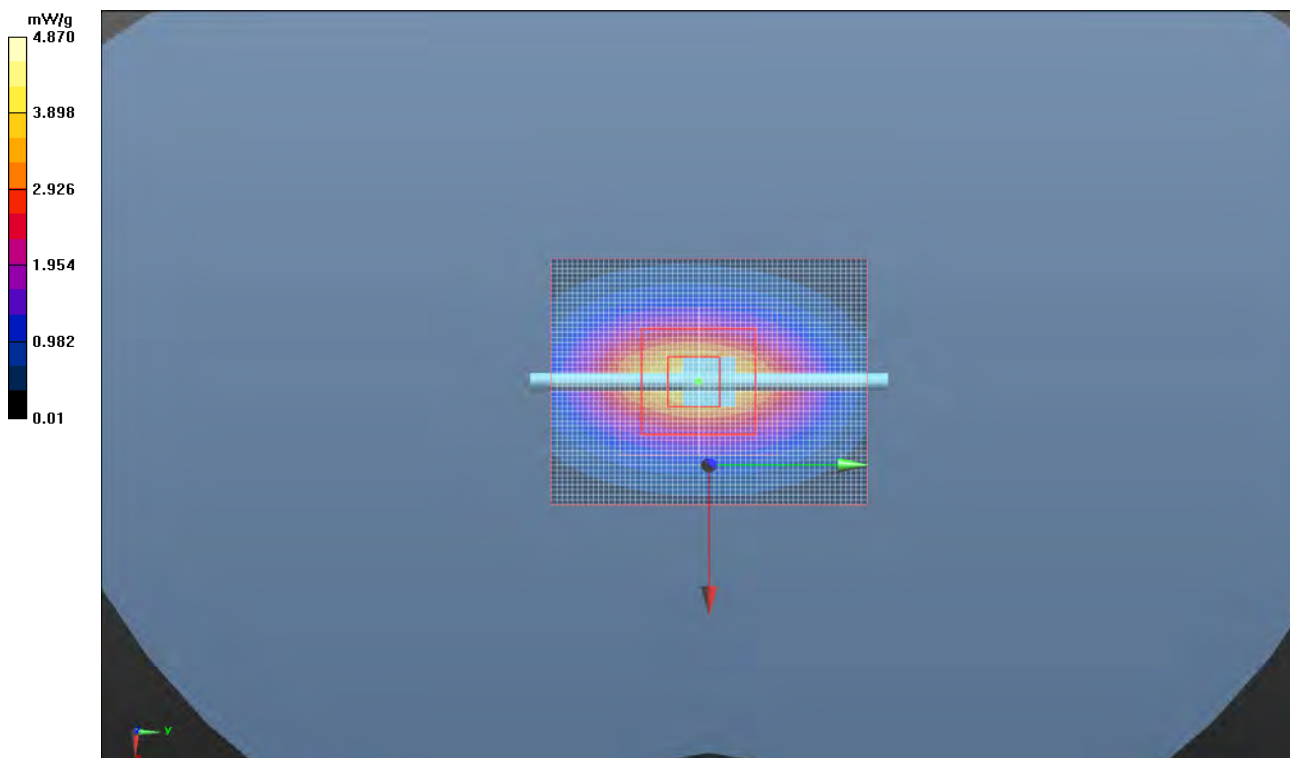

Test Configurations

In normal operation, the EUT can be held in the hand, or next to the head like a cellular handset, or worn on the body. The only Intermec approved accessory for body worn operation is a holster that contains metal. The EUT can only fit in the holster with the top end of the unit pointing down. The holster cup can be attached to the holster belt with either the keypad facing the user, or the side facing the user. In no case can the back of the EUT face the user. For body worn operation, the keypad side was tested. The holster provides 1.5 mm spacing from the keypad side to the flat phantom.

The UMTS antenna is on the left side of the EUT. The closest portion of the antenna is more than 5 cm from the right side of the unit. For body worn operation, in addition to the keypad side, the left and right sides were also tested. The holster provides 1.2 mm spacing from the left or right side to the flat phantom.

An optional snap-on audio accessory is available. It connects to the bottom end of the unit and provides a standard audio jack for connection of a VR10 headset. Measurements were made with and without the headset.

The EUT is powered by a lithium-ion battery, Model 1001AB01. It was fully charged before each SAR evaluation.

Per KDB 648474, among the channels required for normal testing, SAR must be measured on the highest conducted output power channel in each band (see highlighted values in the Output Power section of this report). When the SAR measured on the highest output channel is < 0.8 W/kg, SAR evaluation for the other required channels is unnecessary.

All testing was performed with the EUT configured in a worst-case configuration and operating mode to produce the highest SAR levels. An Agilent 8960 test set, Model E5515C, was used to control the EUT. The following applications were installed on the test set: GSM/GPRS Mobile Test A.13.12 and WCDMA Mobile Test A.17.10. This provided all the necessary tools to operate the EUT in the prescribed manner without any difficulties or equipment limitations.

Summary

The following tables summarize the measured SAR values.

SAR TEST DATA

SAR 2011.02.07

EUT: 1001CP01S	Work Order: ITRM0248
Serial Number: 28311047275	Date: See Data Sheets
Customer: Intermec Technologies Corporation	Temperature: See Data Sheets
Attendees: None	Humidity: See Data Sheets
Project: None	Barometric Pres.: See Data Sheets
Tested by: Jennifer Herrett and Ethan Schoonover	Job Site: EV08

TEST SPECIFICATIONS	Test Method
FCC 2.1093:2011	FCC OET 65C:2001 IEEE Std 1528:2003 FCC KDB 447498 D01 v04 FCC KDB 941225 D01 v02 FCC KDB 648474 D01 V01r05

Health Safety Code 6:2009 RSS-102, Issue 4:2010

COMMENTS
None

DEVIATIONS FROM TEST STANDARD
No Deviations

Configuration # 9 Signature *Jennifer Herrett*

Test Configuration	Frequency Band	Body-Worn Accessory	Transmit Frequency	Transmit Channel	Transmit Mode	Data Rate (Mbps)	EUT Position		Start Power (Conducted)	SAR Drift During Test (dB)	1g SAR Level	Test #
							Left	Right				
Head	Cellular	None	836.6	190	GPRS / 1 slot	GMSK (CS-4)	Left	Cheek	32.69	0.0047	0.237	17
								Tilt	32.69	0.24	0.173	18
							Right	Cheek	32.69	0.12	0.09	19
								Tilt	32.69	-0.03	0.226	20
					WCDMA	12.2 kbps RMC	Left	Cheek	24.5	-0.13	0.246	21
								Tilt	24.5	0.07	0.187	22
Right	Cheek	24.5	0.17	0.212	23							
	Tilt	24.5	0.03	0.319	24b							

Room Temperature (°C):	21.8	Humidity (%):	46.9	Test Date:	08/18/11
Liquid Temperature (°C):	24.1	Barometric Pressure (mb):	1022.5	Tested by:	Jennifer Herrett

Head Test 17 8-18-11

DUT: Handheld Computer (C1); Type: 1001CP01S; Serial: 28311047275

Communication System: GPRS and Edge; Communication System Band: GSM 850; Frequency: 836.6 MHz; Communication System PAR: 9.2 dB
 Medium parameters used: $\sigma = 0.856266$ mho/m, $\epsilon = 39.5455$; $\rho = 1000$ kg/m³, Medium parameters used (interpolated): $f = 836.6$ MHz; $\sigma = 0.858$ mho/m; $\epsilon = 39.53$; $\rho = 1000$ kg/m³
 Phantom section: Left Section
 Measurement Standard: DASYS5 (IEEE/IEC/ANSI C63.19-2007)

DASYS5 Configuration:

Probe: ES3DV3 - SN3173; ConvF(6.01, 6.01, 6.01); Calibrated: 2/23/2011
 Sensor-Surface: 0mm (Fix Surface), Sensor-Surface: 3mm (Mechanical Surface Detection)
 Electronics: DAE4 Sn1237; Calibrated: 11/10/2010
 Phantom: SAM with CRP; Type: SAM; Serial: 1598
 Measurement SW: DASYS2, Version 52.6 (2); SEMCAD X Version 14.4.4 (2829)

Head - Left/Cheek - Mid/Z Scan (1x1x21): Measurement grid: dx=20mm, dy=20mm, dz=5mm
 Maximum value of Total (measured) = 15.386 V/m

Head - Left/Cheek - Mid/Zoom Scan (7x7x7)/Cube 0: Measurement grid: dx=5mm, dy=5mm, dz=5mm
 Reference Value = 17.950 V/m; Power Drift = 0.0047 dB
 Peak SAR (extrapolated) = 0.306 W/kg
SAR(1 g) = 0.237 mW/g; SAR(10 g) = 0.171 mW/g

Info: Interpolated medium parameters used for SAR evaluation.

Maximum value of SAR (measured) = 0.265 mW/g

Head - Left/Cheek - Mid/Reference scan (51x91x1): Measurement grid: dx=30mm, dy=30mm

Info: Interpolated medium parameters used for SAR evaluation.

Maximum value of SAR (interpolated) = 0.281 mW/g

Head - Left/Cheek - Mid/Area scan (71x71x1): Measurement grid: dx=15mm, dy=15mm

Info: Interpolated medium parameters used for SAR evaluation.

Maximum value of SAR (interpolated) = 0.279 mW/g

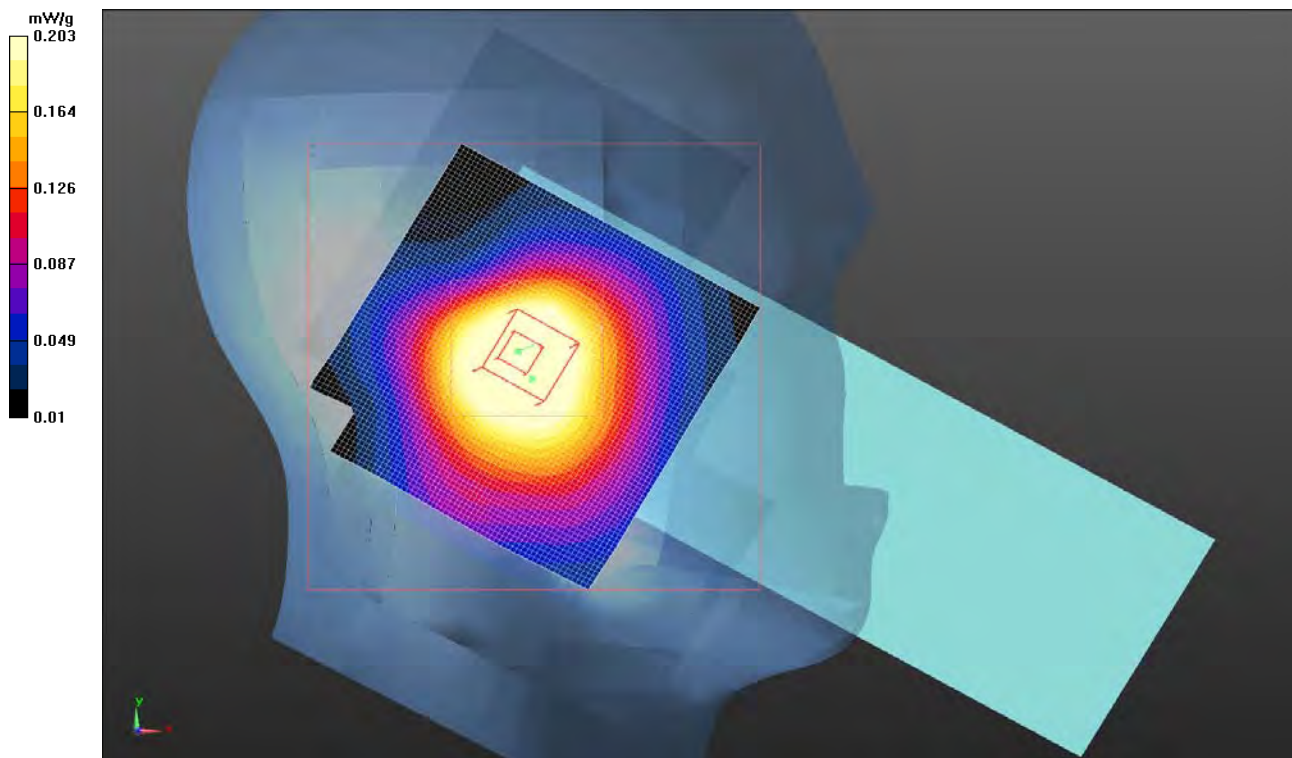

EMC

SAR TEST DATA

Room Temperature (°C):	21.8	Humidity (%):	46.9	Test Date:	08/18/11
Liquid Temperature (°C):	24.1	Barometric Pressure (mb):	1022.5	Tested by:	Jennifer Herrett

Head Test 18 8-18-11

DUT: Handheld Computer (C1); Type: 1001CP01S; Serial: 28311047275

Communication System: GPRS and Edge; Communication System Band: GSM 850; Frequency: 836.6 MHz; Communication System PAR: 9.2 dB
 Medium parameters used: $\sigma = 0.856266$ mho/m, $\epsilon = 39.5455$; $\rho = 1000$ kg/m³, Medium parameters used (interpolated): $f = 836.6$ MHz; $\sigma = 0.858$ mho/m; $\epsilon = 39.53$; $\rho = 1000$ kg/m³
 Phantom section: Left Section
 Measurement Standard: DASYS (IEEE/IEC/ANSI C63.19-2007)

DASYS Configuration:

Probe: ES3DV3 - SN3173; ConvF(6.01, 6.01, 6.01); Calibrated: 2/23/2011
 Sensor-Surface: 0mm (Fix Surface), Sensor-Surface: 3mm (Mechanical Surface Detection)
 Electronics: DAE4 Sn1237; Calibrated: 11/10/2010
 Phantom: SAM with CRP; Type: SAM; Serial: 1598
 Measurement SW: DASYS2, Version 52.6 (2); SEMCAD X Version 14.4.4 (2829)

Head - Left/Tilt - Mid/Z Scan (1x1x21): Measurement grid: dx=20mm, dy=20mm, dz=5mm
 Maximum value of Total (measured) = 13.016 V/m

Head - Left/Tilt - Mid/Reference scan (51x91x1): Measurement grid: dx=30mm, dy=30mm

[Info: Interpolated medium parameters used for SAR evaluation.](#)

Maximum value of SAR (interpolated) = 0.171 mW/g

Head - Left/Tilt - Mid/Zoom Scan (7x7x7)/Cube 0: Measurement grid: dx=5mm, dy=5mm, dz=5mm

Reference Value = 14.959 V/m; Power Drift = 0.24 dB

Peak SAR (extrapolated) = 0.227 W/kg

SAR(1 g) = 0.173 mW/g; SAR(10 g) = 0.121 mW/g

[Info: Interpolated medium parameters used for SAR evaluation.](#)

Maximum value of SAR (measured) = 0.194 mW/g

Head - Left/Tilt - Mid/Area scan (71x71x1): Measurement grid: dx=15mm, dy=15mm

[Info: Interpolated medium parameters used for SAR evaluation.](#)

Maximum value of SAR (interpolated) = 0.185 mW/g

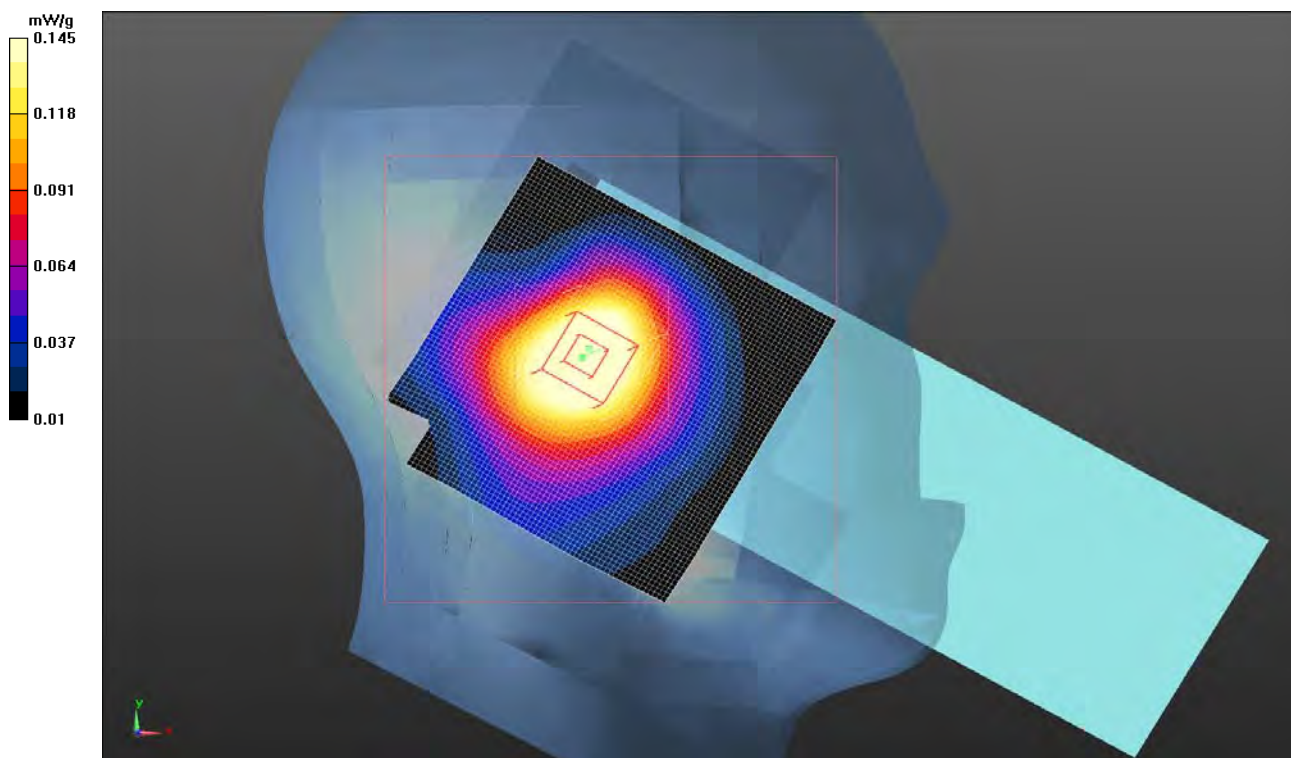

Room Temperature (°C):	23.4	Humidity (%):	43.7	Test Date:	08/17/11
Liquid Temperature (°C):	21.7	Barometric Pressure (mb):	1018.8	Tested by:	Jennifer Herrett

Head Test 19 8-17-11

DUT: Handheld Computer (C1); Type: 1001CP01S; Serial: 28311047275

Communication System: GPRS and Edge; Communication System Band: GSM 850; Frequency: 836.6 MHz; Communication System PAR: 9.2 dB
 Medium parameters used: $\sigma = 0.884189$ mho/m, $\epsilon = 41.7001$; $\rho = 1000$ kg/m³, Medium parameters used (interpolated): $f = 836.6$ MHz; $\sigma = 0.886$ mho/m; $\epsilon = 41.68$; $\rho = 1000$ kg/m³
 Phantom section: Right Section
 Measurement Standard: DASYS (IEEE/IEC/ANSI C63.19-2007)

DASYS Configuration:

Probe: ES3DV3 - SN3173; ConvF(6.01, 6.01, 6.01); Calibrated: 2/23/2011
 Sensor-Surface: 0mm (Fix Surface), Sensor-Surface: 3mm (Mechanical Surface Detection)
 Electronics: DAE4 Sn1237; Calibrated: 11/10/2010
 Phantom: SAM with CRP; Type: SAM; Serial: 1598
 Measurement SW: DASYS2, Version 52.6 (2); SEMCAD X Version 14.4.4 (2829)

Head - Right/Cheek - Mid/Z Scan (1x1x21): Measurement grid: dx=20mm, dy=20mm, dz=5mm
 Maximum value of Total (measured) = 8.877 V/m

Head - Right/Cheek - Mid/Reference scan (51x91x1): Measurement grid: dx=30mm, dy=30mm

[Info: Interpolated medium parameters used for SAR evaluation.](#)
 Maximum value of SAR (interpolated) = 0.098 mW/g

Head - Right/Cheek - Mid/Area scan (71x71x1): Measurement grid: dx=15mm, dy=15mm

[Info: Interpolated medium parameters used for SAR evaluation.](#)
 Maximum value of SAR (interpolated) = 0.106 mW/g

Head - Right/Cheek - Mid/Zoom Scan (8x8x7)/Cube 0: Measurement grid: dx=5mm, dy=5mm, dz=5mm
 Reference Value = 10.728 V/m; Power Drift = 0.12 dB
 Peak SAR (extrapolated) = 0.128 W/kg
SAR(1 g) = 0.090 mW/g; SAR(10 g) = 0.061 mW/g

[Info: Interpolated medium parameters used for SAR evaluation.](#)
 Maximum value of SAR (measured) = 0.103 mW/g

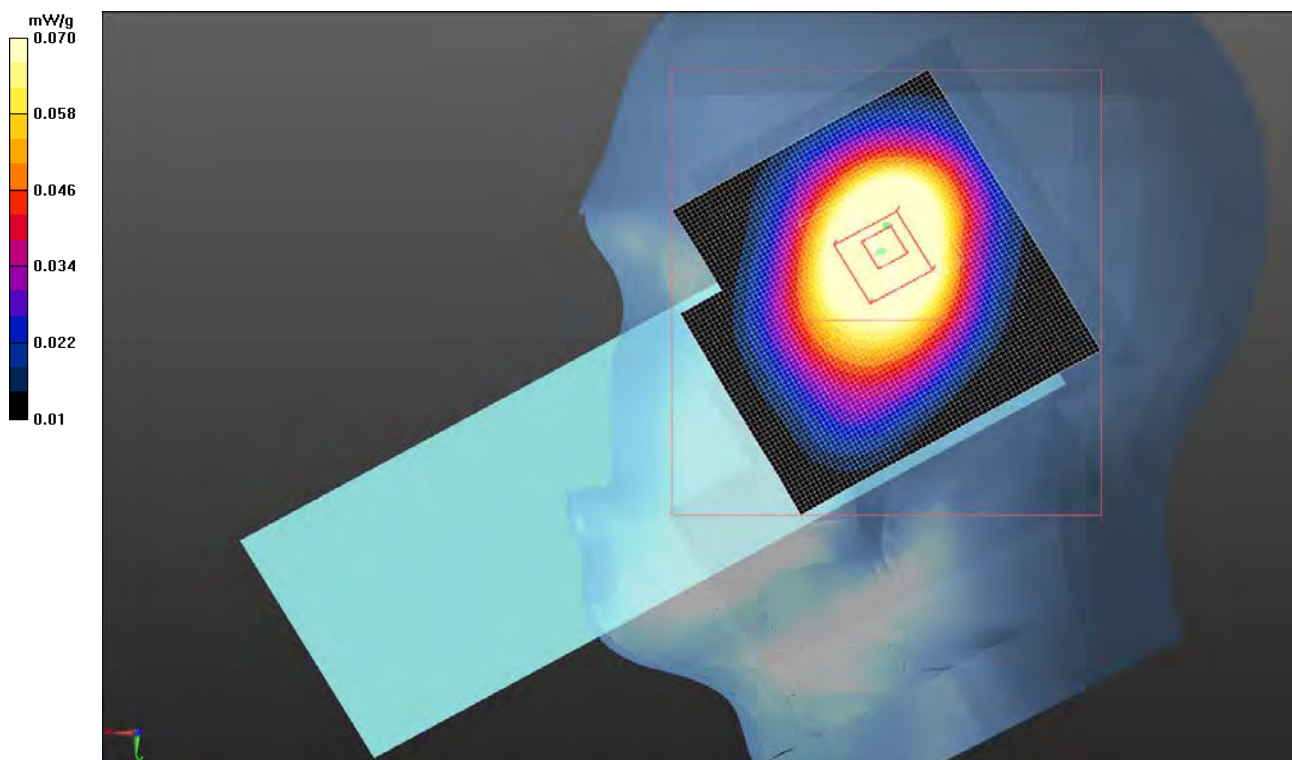

EMC

SAR TEST DATA

Room Temperature (°C):	21.8	Humidity (%):	46.9	Test Date:	08/18/11
Liquid Temperature (°C):	24.1	Barometric Pressure (mb):	1022.5	Tested by:	Jennifer Herrett

Head Test 20 8-18-11

DUT: Handheld Computer (C1); Type: 1001CP01S; Serial: 28311047275

Communication System: GPRS and Edge; Communication System Band: GSM 850; Frequency: 836.6 MHz; Communication System PAR: 9.2 dB
 Medium parameters used (interpolated): $f = 836.6$ MHz; $\sigma = 0.858$ mho/m; $\epsilon = 39.53$; $\rho = 1000$ kg/m³, Medium parameters used: $\sigma = 0.856266$ mho/m, $\epsilon = 39.5455$; $\rho = 1000$ kg/m³
 Phantom section: Right Section
 Measurement Standard: DASYS5 (IEEE/IEC/ANSI C63.19-2007)

DASYS5 Configuration:

Probe: ES3DV3 - SN3173; ConvF(6.01, 6.01, 6.01); Calibrated: 2/23/2011
 Sensor-Surface: 3mm (Mechanical Surface Detection), Sensor-Surface: 0mm (Fix Surface)
 Electronics: DAE4 Sn1237; Calibrated: 11/10/2010
 Phantom: SAM with CRP; Type: SAM; Serial: 1598
 Measurement SW: DASYS2, Version 52.6 (2); SEMCAD X Version 14.4.4 (2829)

Head - Right/Tilt - Mid/Reference scan (51x91x1): Measurement grid: dx=30mm, dy=30mm

Info: Interpolated medium parameters used for SAR evaluation.

Maximum value of SAR (interpolated) = 0.251 mW/g

Head - Right/Tilt - Mid/Zoom Scan (7x7x7)/Cube 0: Measurement grid: dx=5mm, dy=5mm, dz=5mm

Reference Value = 17.654 V/m; Power Drift = -0.03 dB

Peak SAR (extrapolated) = 0.298 W/kg

SAR(1 g) = 0.226 mW/g; SAR(10 g) = 0.159 mW/g

Info: Interpolated medium parameters used for SAR evaluation.

Maximum value of SAR (measured) = 0.254 mW/g

Head - Right/Tilt - Mid/Z Scan (1x1x21): Measurement grid: dx=20mm, dy=20mm, dz=5mm

Maximum value of Total (measured) = 15.107 V/m

Head - Right/Tilt - Mid/Area scan (71x71x1): Measurement grid: dx=15mm, dy=15mm

Info: Interpolated medium parameters used for SAR evaluation.

Maximum value of SAR (interpolated) = 0.268 mW/g

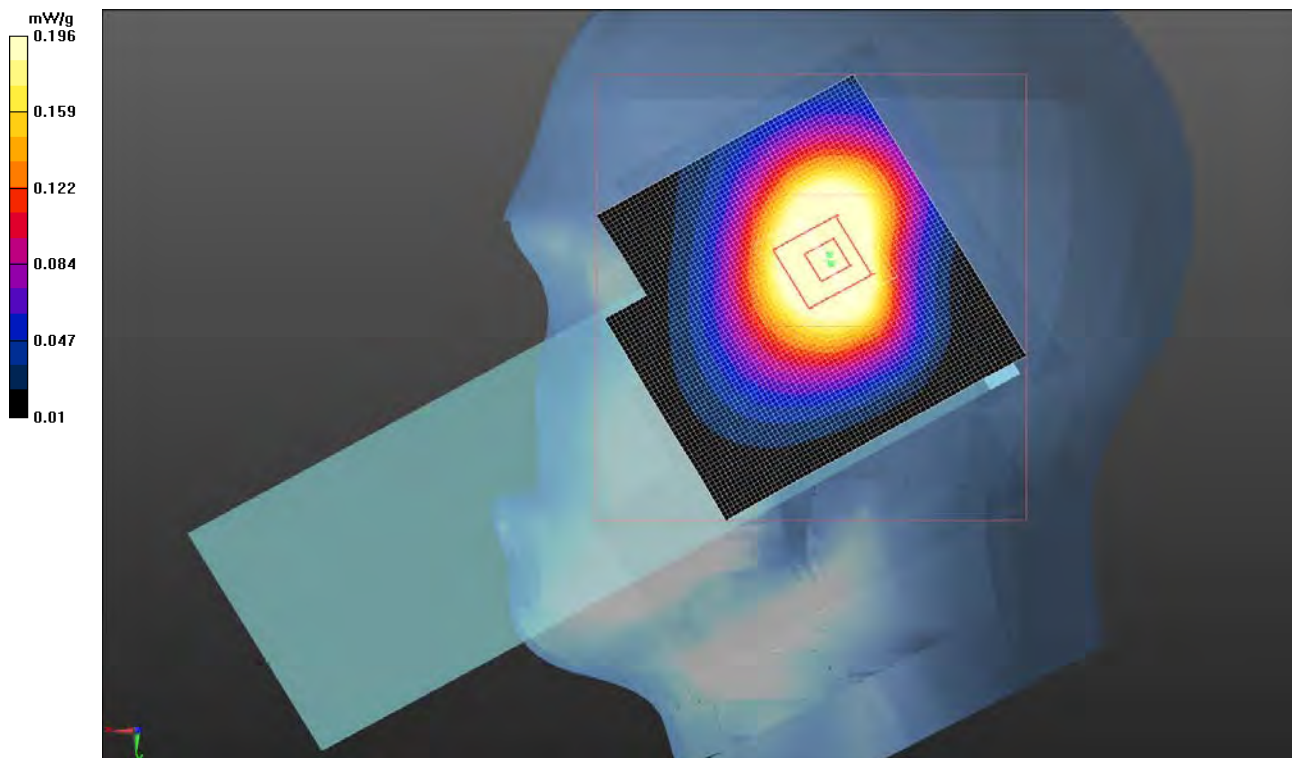

Room Temperature (°C):	25.6	Humidity (%):	37.2	Test Date:	08/16/11
Liquid Temperature (°C):	23.4	Barometric Pressure (mb):	1015.9	Tested by:	Ethan Schoonover

Head Test 21 8-16-11

DUT: Handheld Computer (C1); Type: 1001CP01S; Serial: 28311047275

Communication System: CW; Frequency: 836.52 MHz

Medium parameters used: $\sigma = 0.858264$ mho/m, $\epsilon_r = 39.9222$; $\rho = 1000$ kg/m³, Medium parameters used (interpolated): $f = 836.52$ MHz; $\sigma = 0.86$ mho/m; $\epsilon_r = 39.902$; $\rho = 1000$ kg/m³

Phantom section: Left Section

Measurement Standard: DASYS (IEEE/IEC/ANSI C63.19-2007)

DASY5 Configuration:

Probe: ES3DV3 - SN3246; ConvF(6.04, 6.04, 6.04); Calibrated: 11/11/2010

Sensor-Surface: 0mm (Fix Surface), Sensor-Surface: 3mm (Mechanical Surface Detection)

Electronics: DAE4 Sn1237; Calibrated: 11/10/2010

Phantom: SAM with CRP; Type: SAM; Serial: 1598

Measurement SW: DASY52, Version 52.6 (2); SEMCAD X Version 14.4.4 (2829)

Head - Left/Cheek - Mid/Z Scan (1x1x21): Measurement grid: dx=20mm, dy=20mm, dz=5mm
Maximum value of Total (measured) = 15.493 V/m

Head - Left/Cheek - Mid/Zoom Scan (7x7x7)/Cube 0: Measurement grid: dx=5mm, dy=5mm, dz=5mm
Reference Value = 18.237 V/m; Power Drift = -0.13 dB
Peak SAR (extrapolated) = 0.308 W/kg
SAR(1 g) = 0.246 mW/g; SAR(10 g) = 0.177 mW/g

[Info: Interpolated medium parameters used for SAR evaluation.](#)

Maximum value of SAR (measured) = 0.272 mW/g

Head - Left/Cheek - Mid/Reference scan (51x91x1): Measurement grid: dx=30mm, dy=30mm

[Info: Interpolated medium parameters used for SAR evaluation.](#)

Maximum value of SAR (interpolated) = 0.316 mW/g

Head - Left/Cheek - Mid/Area scan (71x71x1): Measurement grid: dx=15mm, dy=15mm

[Info: Interpolated medium parameters used for SAR evaluation.](#)

Maximum value of SAR (interpolated) = 0.270 mW/g

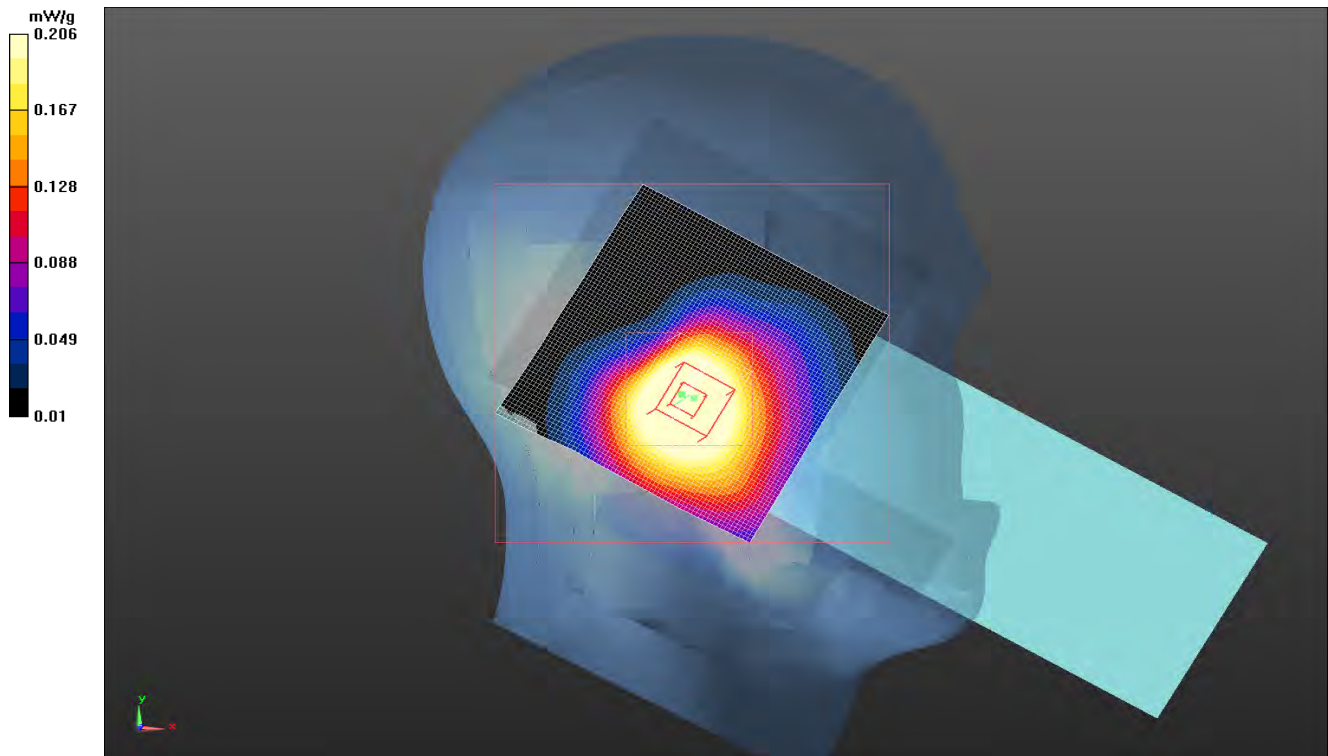

EMC

SAR TEST DATA

Room Temperature (°C):	25.6	Humidity (%):	37.2	Test Date:	08/16/11
Liquid Temperature (°C):	23.4	Barometric Pressure (mb):	1015.9	Tested by:	Ethan Schoonover

Head Test 22 8-16-11

DUT: Handheld Computer (C1); Type: 1001CP01S; Serial: 28311047275

Communication System: CW; Frequency: 836.52 MHz

Medium parameters used: $\sigma = 0.858264$ mho/m, $\epsilon_r = 39.9222$; $\rho = 1000$ kg/m³, Medium parameters used (interpolated): $f = 836.52$ MHz; $\sigma = 0.86$ mho/m; $\epsilon_r = 39.902$; $\rho = 1000$ kg/m³

Phantom section: Left Section

Measurement Standard: DASYS (IEEE/IEC/ANSI C63.19-2007)

DASY5 Configuration:

Probe: ES3DV3 - SN3246; ConvF(6.04, 6.04, 6.04); Calibrated: 11/11/2010

Sensor-Surface: 0mm (Fix Surface), Sensor-Surface: 3mm (Mechanical Surface Detection)

Electronics: DAE4 Sn1237; Calibrated: 11/10/2010

Phantom: SAM with CRP; Type: SAM; Serial: 1598

Measurement SW: DASY52, Version 52.6 (2); SEMCAD X Version 14.4.4 (2829)

Head - Left/Tilt - Mid/Z Scan (1x1x21): Measurement grid: dx=20mm, dy=20mm, dz=5mm
Maximum value of Total (measured) = 13.773 V/m

Head - Left/Tilt - Mid/Reference scan (51x91x1): Measurement grid: dx=30mm, dy=30mm

[Info: Interpolated medium parameters used for SAR evaluation.](#)

Maximum value of SAR (interpolated) = 0.223 mW/g

Head - Left/Tilt - Mid/Zoom Scan (7x7x7)/Cube 0: Measurement grid: dx=5mm, dy=5mm, dz=5mm

Reference Value = 15.622 V/m; Power Drift = 0.07 dB

Peak SAR (extrapolated) = 0.241 W/kg

SAR(1 g) = 0.187 mW/g; SAR(10 g) = 0.132 mW/g

[Info: Interpolated medium parameters used for SAR evaluation.](#)

Maximum value of SAR (measured) = 0.210 mW/g

Head - Left/Tilt - Mid/Area scan (71x71x1): Measurement grid: dx=15mm, dy=15mm

[Info: Interpolated medium parameters used for SAR evaluation.](#)

Maximum value of SAR (interpolated) = 0.216 mW/g

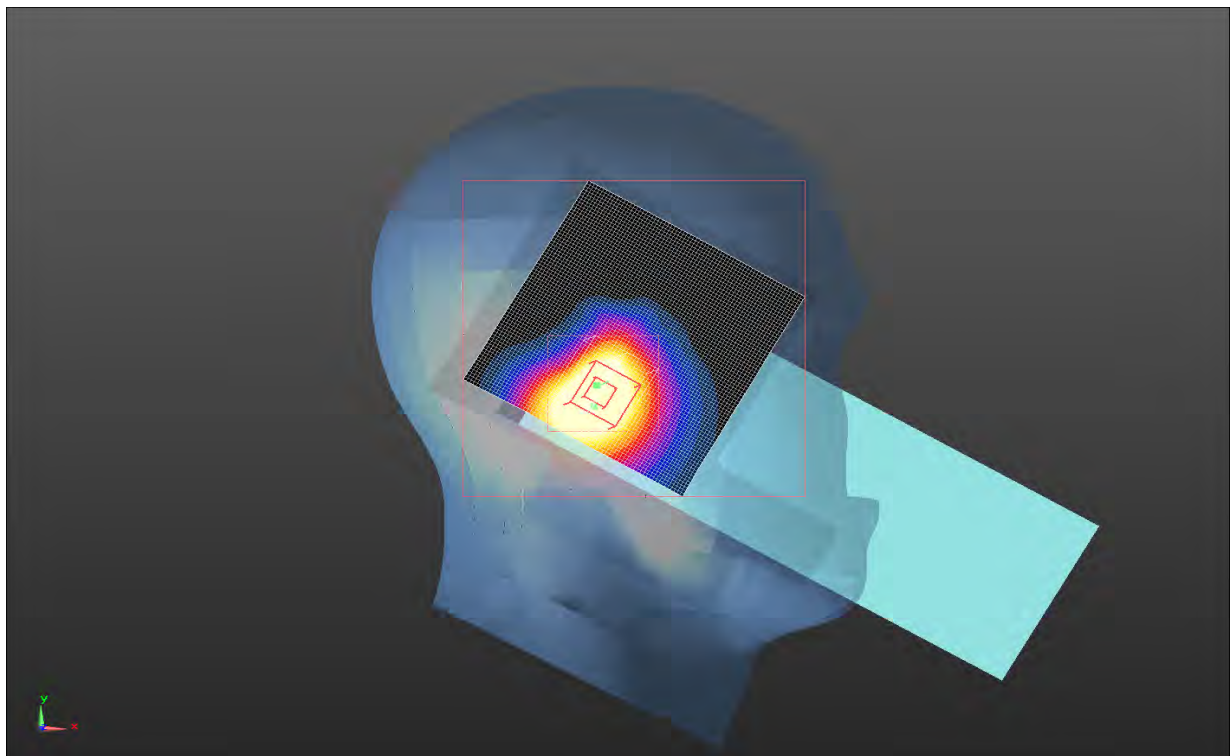
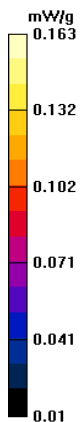

Room Temperature (°C):	26.3	Humidity (%):	27.6	Test Date:	08/16/11
Liquid Temperature (°C):	23.3	Barometric Pressure (mb):	1015.9	Tested by:	Ethan Schoonover

Head Test 23 8-16-11

DUT: Handheld Computer (C1); Type: 1001CP01S; Serial: 28311047275

Communication System: CW; Frequency: 836.52 MHz

Medium parameters used: $\sigma = 0.858264$ mho/m, $\epsilon_r = 39.9222$; $\rho = 1000$ kg/m³, Medium parameters used (interpolated): $f = 836.52$ MHz; $\sigma = 0.86$ mho/m; $\epsilon_r = 39.902$; $\rho = 1000$ kg/m³

Phantom section: Right Section

Measurement Standard: DASYS (IEEE/IEC/ANSI C63.19-2007)

DASY5 Configuration:

Probe: ES3DV3 - SN3246; ConvF(6.04, 6.04, 6.04); Calibrated: 11/11/2010

Sensor-Surface: 0mm (Fix Surface), Sensor-Surface: 3mm (Mechanical Surface Detection)

Electronics: DAE4 Sn1237; Calibrated: 11/10/2010

Phantom: SAM with CRP; Type: SAM; Serial: 1598

Measurement SW: DASYS2, Version 52.6 (2); SEMCAD X Version 14.4.4 (2829)

Head - Left/Cheek - Mid/Z Scan (1x1x21): Measurement grid: dx=20mm, dy=20mm, dz=5mm

Maximum value of Total (measured) = 14.571 V/m

Head - Left/Cheek - Mid/Zoom Scan (7x7x7)/Cube 0: Measurement grid: dx=5mm, dy=5mm, dz=5mm

Reference Value = 16.413 V/m; Power Drift = 0.17 dB

Peak SAR (extrapolated) = 0.284 W/kg

SAR(1 g) = 0.212 mW/g; SAR(10 g) = 0.150 mW/g

[Info: Interpolated medium parameters used for SAR evaluation.](#)

Maximum value of SAR (measured) = 0.242 mW/g

Head - Left/Cheek - Mid/Reference scan (51x91x1): Measurement grid: dx=30mm, dy=30mm

[Info: Interpolated medium parameters used for SAR evaluation.](#)

Maximum value of SAR (interpolated) = 0.257 mW/g

Head - Left/Cheek - Mid/Area scan (71x71x1): Measurement grid: dx=15mm, dy=15mm

[Info: Interpolated medium parameters used for SAR evaluation.](#)

Maximum value of SAR (interpolated) = 0.244 mW/g

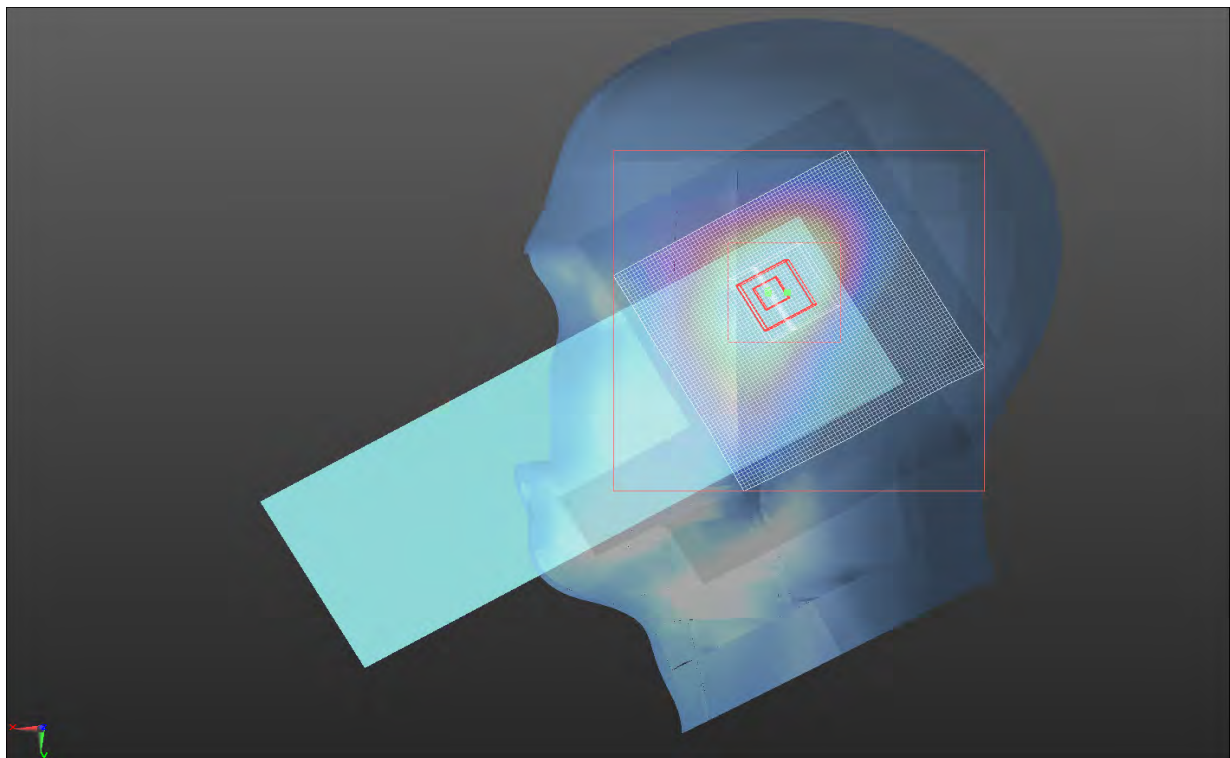
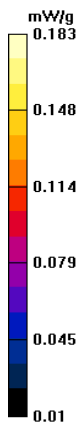

EMC

SAR TEST DATA

Room Temperature (°C):	23.9	Humidity (%):	45.7	Test Date:	08/18/11
Liquid Temperature (°C):	22	Barometric Pressure (mb):	1022.5	Tested by:	Jennifer Herrett

Head Test 24b 8-18-11

DUT: Handheld Computer (C1); Type: 1001CP01S; Serial: 28311047275

Communication System: CW; Frequency: 836.6 MHz

Medium parameters used (interpolated): $f = 836.6$ MHz; $\sigma = 0.886$ mho/m; $\epsilon = 41.68$; $\rho = 1000$ kg/m³, Medium parameters used: $\sigma = 0.884189$ mho/m, $\epsilon = 41.7001$; $\rho = 1000$ kg/m³

Phantom section: Right Section

Measurement Standard: DASYS (IEEE/IEC/ANSI C63.19-2007)

DASYS Configuration:

Probe: ES3DV3 - SN3173; ConvF(6.01, 6.01, 6.01); Calibrated: 2/23/2011

Sensor-Surface: 3mm (Mechanical Surface Detection), Sensor-Surface: 0mm (Fix Surface)

Electronics: DAE4 Sn1237; Calibrated: 11/10/2010

Phantom: SAM with CRP; Type: SAM; Serial: 1598

Measurement SW: DASYS2, Version 52.6 (2); SEMCAD X Version 14.4.4 (2829)

Head - Right/Tilt - Mid/Reference scan (51x91x1): Measurement grid: dx=30mm, dy=30mm

Info: Interpolated medium parameters used for SAR evaluation.

Maximum value of SAR (interpolated) = 0.380 mW/g

Head - Right/Tilt - Mid/Zoom Scan (7x7x7)/Cube 0: Measurement grid: dx=5mm, dy=5mm, dz=5mm

Reference Value = 20.846 V/m; Power Drift = 0.03 dB

Peak SAR (extrapolated) = 0.438 W/kg

SAR(1 g) = 0.319 mW/g; SAR(10 g) = 0.225 mW/g

Info: Interpolated medium parameters used for SAR evaluation.

Maximum value of SAR (measured) = 0.360 mW/g

Head - Right/Tilt - Mid/Z Scan (1x1x21): Measurement grid: dx=20mm, dy=20mm, dz=5mm

Maximum value of Total (measured) = 17.447 V/m

Head - Right/Tilt - Mid/Area scan (71x71x1): Measurement grid: dx=15mm, dy=15mm

Info: Interpolated medium parameters used for SAR evaluation.

Maximum value of SAR (interpolated) = 0.372 mW/g

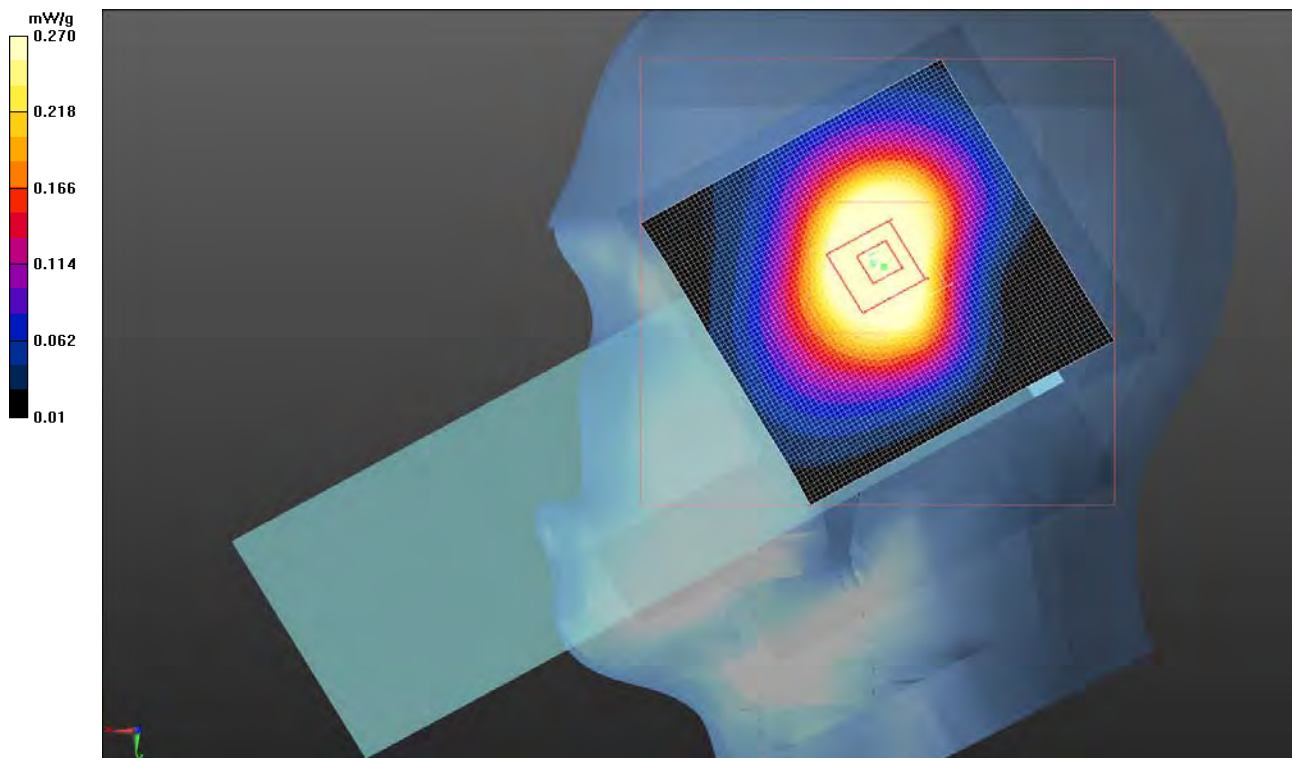

EMC SAR TEST DATA

Room Temperature (°C):	23.9	Humidity (%):	45.7	Test Date:	08/18/11
Liquid Temperature (°C):	22	Barometric Pressure (mb):	1022.5	Tested by:	Jennifer Herrett

Head Test 24b 8-18-11

DUT: Handheld Computer (C1); Type: 1001CP01S; Serial: 28311047275

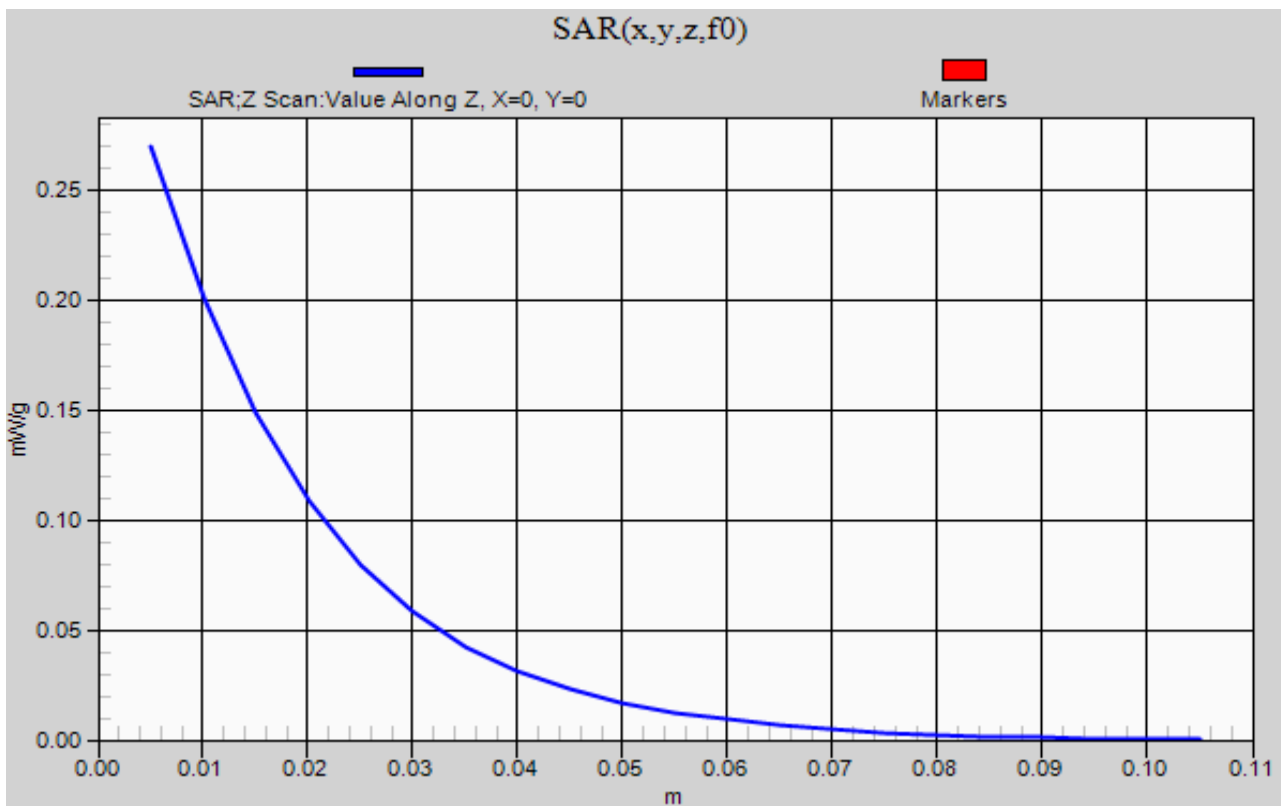

SAR TEST DATA

EMC

EUT:	1001CP01S	Work Order:	ITRM0248
Serial Number:	28311047275	Date:	See Data Sheets
Customer:	Intermec Technologies Corporation	Temperature:	See Data Sheets
Attendees:	None	Humidity:	See Data Sheets
Project:	None	Barometric Pres.:	See Data Sheets
Tested by:	Jennifer Herrett and Ethan Schoonover	Job Site:	EV08
TEST SPECIFICATIONS		Test Method	
FCC 2.1093:2011		FCC OET 65C:2001 IEEE Std 1528:2003 FCC KDB 447498 D01 v04 FCC KDB 941225 D01 v02 FCC KDB 648474 D01 V01r05	
Health Safety Code 6:2009		RSS-102, Issue 4:2010	
COMMENTS			
None			
DEVIATIONS FROM TEST STANDARD			
No Deviations			
Configuration #	7 & 8	Signature <i>Jennifer Herrett</i>	

Test Configuration	Frequency Band	Body-Worn Accessory	Transmit Frequency	Transmit Channel	Transmit Mode	Data Rate (Mbps)	Audio Accessory	EUT Position	Start Power (Conducted)	SAR Drift During Test (dB)	1g SAR Level	Test #		
Body	Cellular	Holster	836.6	190	E-GPRS / 1 slot	GMSK (MCS 4)	none	Right	32.69	0.04	0.126	17		
								Front	32.69	-0.04	0.249	18		
								Left	32.69	0.05	0.486	19		
							VR10 Headset	Worst Case	32.69	0.01	0.262	20		
							WCDMA / Test Loop 1	12.2 kbps RMC	None	Right	24.5	0.11	0.108	21
										Front	24.5	0.07	0.141	22
					Left	24.5				0.02	0.310	23		
					VR10 Headset	Worst Case	24.5	-0.02	0.343	24				

Room Temperature (°C):	23	Humidity (%):	45.7	Test Date:	08/09/11
Liquid Temperature (°C):	21.2	Barometric Pressure (mb):	1018.6	Tested by:	Ethan Schoonover

Body Test 17b 8-9-11

DUT: Handheld Computer (C1); Type: 1001CP01S; Serial: 28311047275

Communication System: GPRS and Edge; Communication System Band: GSM 850; Frequency: 836.6 MHz; Communication System PAR: 9.2 dB
 Medium parameters used: $\sigma = 1.0111$ mho/m, $\epsilon_r = 56.5118$; $\rho = 1000$ kg/m³, Medium parameters used (interpolated): $f = 836.6$ MHz; $\sigma = 1.013$ mho/m; $\epsilon_r = 56.502$; $\rho = 1000$ kg/m³
 Phantom section: Flat Section
 Measurement Standard: DASYS5 (IEEE/IEC/ANSI C63.19-2007)

DASY5 Configuration:

Probe: ES3DV3 - SN3246; ConvF(6.1, 6.1, 6.1); Calibrated: 11/11/2010
 Sensor-Surface: 0mm (Fix Surface), Sensor-Surface: 3mm (Mechanical Surface Detection)
 Electronics: DAE4 Sn1237; Calibrated: 11/10/2010
 Phantom: ELI 4.0; Type: QDOVA001BA; Serial: 1096
 Measurement SW: DASY52, Version 52.6 (2); SEMCAD X Version 14.4.4 (2829)

Body/Body - Mid/Z Scan (1x1x21): Measurement grid: dx=20mm, dy=20mm, dz=5mm
 Maximum value of Total (measured) = 10.065 V/m

Body/Body - Mid/Zoom Scan (7x7x7)/Cube 0: Measurement grid: dx=5mm, dy=5mm, dz=5mm
 Reference Value = 12.164 V/m; Power Drift = 0.04 dB
 Peak SAR (extrapolated) = 0.172 W/kg
SAR(1 g) = 0.126 mW/g; SAR(10 g) = 0.087 mW/g

Info: Interpolated medium parameters used for SAR evaluation.

Maximum value of SAR (measured) = 0.142 mW/g

Body/Body - Mid/Area scan (71x141x1): Measurement grid: dx=15mm, dy=15mm

Info: Interpolated medium parameters used for SAR evaluation.

Maximum value of SAR (interpolated) = 0.138 mW/g

Body/Body - Mid/Reference scan (51x101x1): Measurement grid: dx=30mm, dy=30mm

Info: Interpolated medium parameters used for SAR evaluation.

Maximum value of SAR (interpolated) = 0.150 mW/g

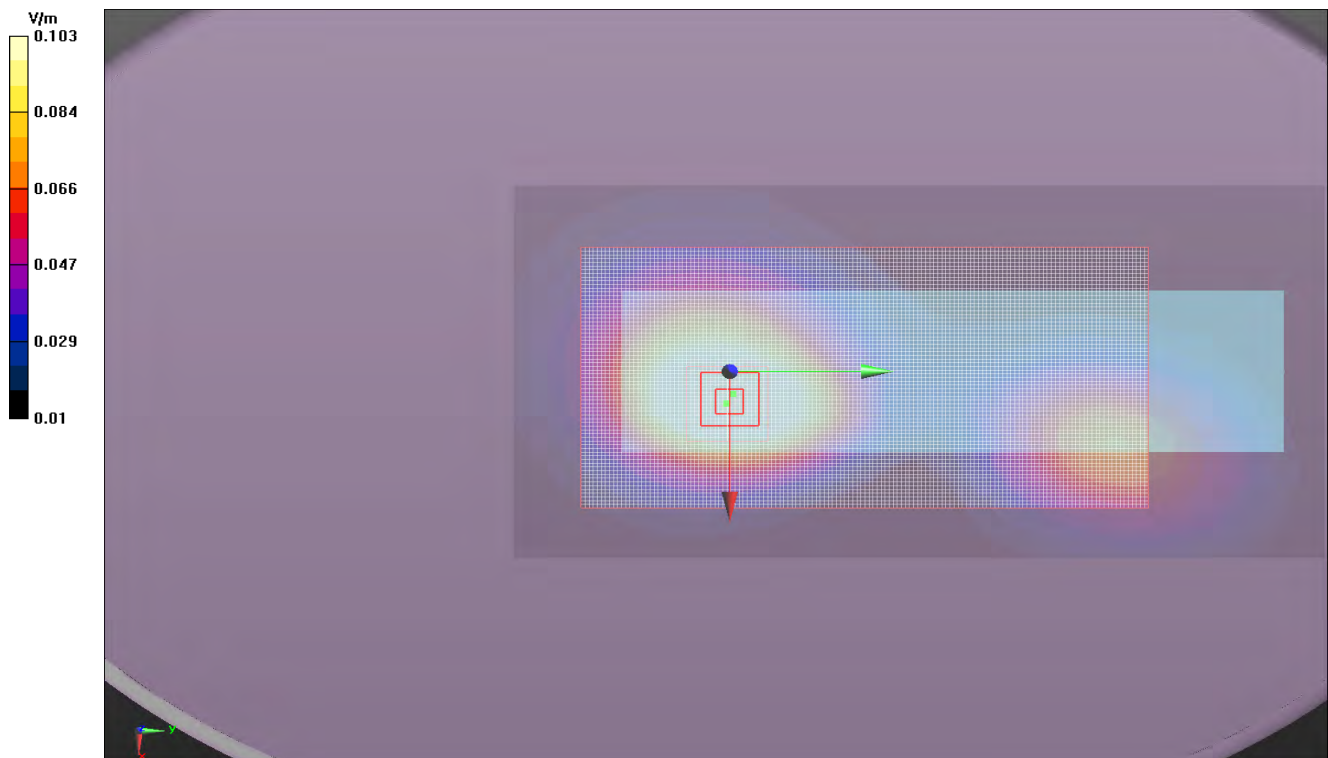

Room Temperature (°C):	23	Humidity (%):	40.8	Test Date:	08/09/11
Liquid Temperature (°C):	23.3	Barometric Pressure (mb):	1018.6	Tested by:	Ethan Schoonover

Body Test 18 8-9-11

DUT: Handheld Computer (C1); Type: 1001CP01S; Serial: 28311047275

Communication System: GPRS and Edge; Communication System Band: GSM 850; Frequency: 836.6 MHz; Communication System PAR: 9.2 dB
 Medium parameters used: $\sigma = 1.0111$ mho/m, $\epsilon_r = 56.5118$; $\rho = 1000$ kg/m³, Medium parameters used (interpolated): $f = 836.6$ MHz; $\sigma = 1.013$ mho/m; $\epsilon_r = 56.502$; $\rho = 1000$ kg/m³
 Phantom section: Flat Section
 Measurement Standard: DASYS (IEEE/IEC/ANSI C63.19-2007)

DASY5 Configuration:

Probe: ES3DV3 - SN3246; ConvF(6.1, 6.1, 6.1); Calibrated: 11/11/2010
 Sensor-Surface: 0mm (Fix Surface), Sensor-Surface: 3mm (Mechanical Surface Detection)
 Electronics: DAE4 Sn1237; Calibrated: 11/10/2010
 Phantom: ELI 4.0; Type: QDOVA001BA; Serial: 1096
 Measurement SW: DASY52, Version 52.6 (2); SEMCAD X Version 14.4.4 (2829)

Body/Body - Mid/Z Scan (1x1x21): Measurement grid: dx=20mm, dy=20mm, dz=5mm
 Maximum value of Total (measured) = 14.380 V/m

Body/Body - Mid/Zoom Scan (7x7x7)/Cube 0: Measurement grid: dx=5mm, dy=5mm, dz=5mm
 Reference Value = 16.962 V/m; Power Drift = -0.04 dB
 Peak SAR (extrapolated) = 0.338 W/kg
SAR(1 g) = 0.249 mW/g; SAR(10 g) = 0.172 mW/g

[Info: Interpolated medium parameters used for SAR evaluation.](#)

Maximum value of SAR (measured) = 0.284 mW/g

Body/Body - Mid/Area scan (71x161x1): Measurement grid: dx=15mm, dy=15mm

[Info: Interpolated medium parameters used for SAR evaluation.](#)

Maximum value of SAR (interpolated) = 0.300 mW/g

Body/Body - Mid/Reference scan (51x101x1): Measurement grid: dx=30mm, dy=30mm

[Info: Interpolated medium parameters used for SAR evaluation.](#)

Maximum value of SAR (interpolated) = 0.302 mW/g

Body/Body - Mid/Zoom Scan 2 (7x7x7)/Cube 0: Measurement grid: dx=5mm, dy=5mm, dz=5mm

Reference Value = 16.962 V/m; Power Drift = 0.03 dB

Peak SAR (extrapolated) = 0.271 W/kg

SAR(1 g) = 0.209 mW/g; SAR(10 g) = 0.149 mW/g

[Info: Interpolated medium parameters used for SAR evaluation.](#)

Maximum value of SAR (measured) = 0.234 mW/g

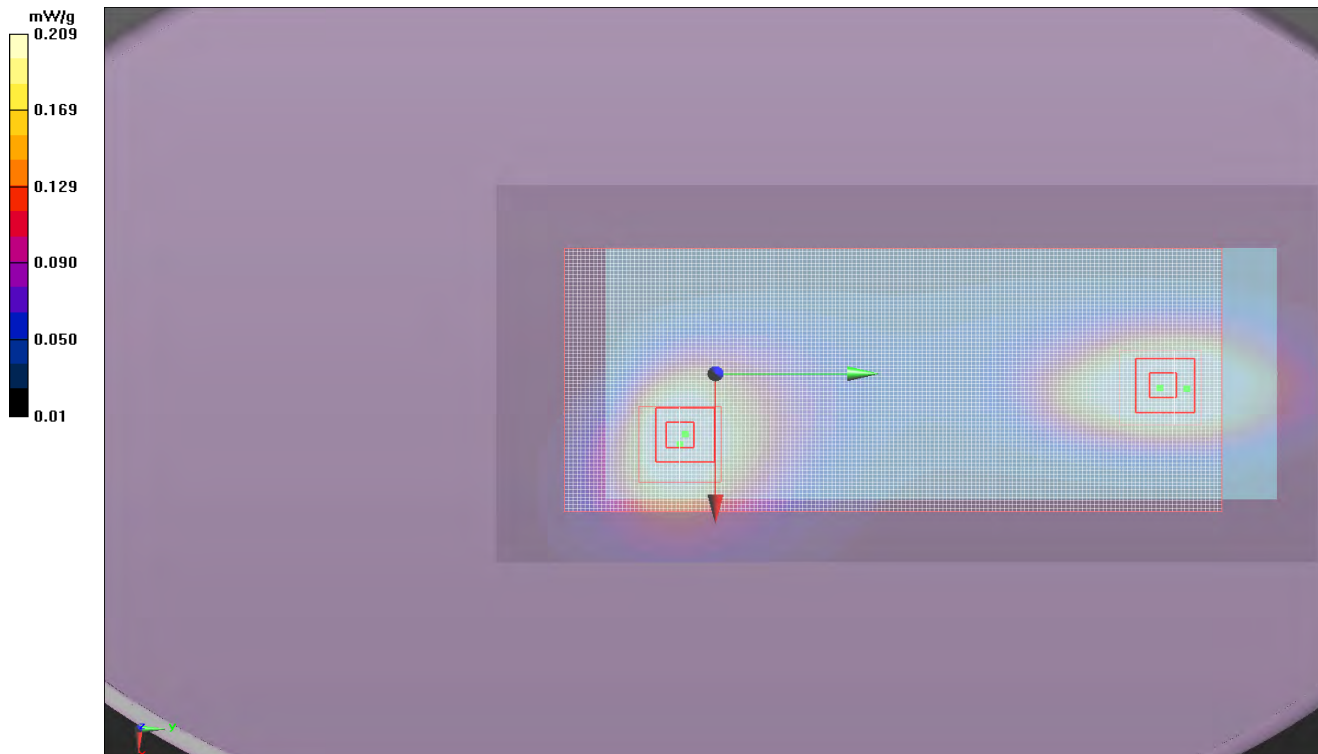

Room Temperature (°C):	23	Humidity (%):	45.5	Test Date:	08/09/11
Liquid Temperature (°C):	21.1	Barometric Pressure (mb):	1018.6	Tested by:	Ethan Schoonover

Body Test 19 8-9-11

DUT: Handheld Computer (C1); Type: 1001CP01S; Serial: 28311047275

Communication System: GPRS and Edge; Communication System Band: GSM 850; Frequency: 836.6 MHz; Communication System PAR: 9.2 dB
 Medium parameters used: $\sigma = 1.0111$ mho/m, $\epsilon_r = 56.5118$; $\rho = 1000$ kg/m³, Medium parameters used (interpolated): $f = 836.6$ MHz; $\sigma = 1.013$ mho/m; $\epsilon_r = 56.502$; $\rho = 1000$ kg/m³
 Phantom section: Flat Section
 Measurement Standard: DASYS5 (IEEE/IEC/ANSI C63.19-2007)

DASY5 Configuration:

Probe: ES3DV3 - SN3246; ConvF(6.1, 6.1, 6.1); Calibrated: 11/11/2010
 Sensor-Surface: 0mm (Fix Surface), Sensor-Surface: 3mm (Mechanical Surface Detection)
 Electronics: DAE4 Sn1237; Calibrated: 11/10/2010
 Phantom: ELI 4.0; Type: QDOVA001BA; Serial: 1096
 Measurement SW: DASY52, Version 52.6 (2); SEMCAD X Version 14.4.4 (2829)

Body/Body - Mid/Z Scan (1x1x21): Measurement grid: dx=20mm, dy=20mm, dz=5mm
 Maximum value of Total (measured) = 19.533 V/m

Body/Body - Mid/Zoom Scan (7x7x7)/Cube 0: Measurement grid: dx=5mm, dy=5mm, dz=5mm
 Reference Value = 23.807 V/m; Power Drift = 0.01 dB
 Peak SAR (extrapolated) = 0.685 mW/kg
SAR(1 g) = 0.486 mW/g; SAR(10 g) = 0.327 mW/g

Info: Interpolated medium parameters used for SAR evaluation.

Maximum value of SAR (measured) = 0.561 mW/g

Body/Body - Mid/Area scan (71x141x1): Measurement grid: dx=15mm, dy=15mm

Info: Interpolated medium parameters used for SAR evaluation.

Maximum value of SAR (interpolated) = 0.556 mW/g

Body/Body - Mid/Reference scan (51x101x1): Measurement grid: dx=30mm, dy=30mm

Info: Interpolated medium parameters used for SAR evaluation.

Maximum value of SAR (interpolated) = 0.689 mW/g

Body/Body - Mid/Zoom Scan 2 (8x11x7)/Cube 0: Measurement grid: dx=5mm, dy=5mm, dz=5mm

Reference Value = 23.807 V/m; Power Drift = -0.05 dB

Peak SAR (extrapolated) = 0.705 W/kg

SAR(1 g) = 0.488 mW/g; SAR(10 g) = 0.327 mW/g

Info: Interpolated medium parameters used for SAR evaluation.

Maximum value of SAR (measured) = 0.563 mW/g

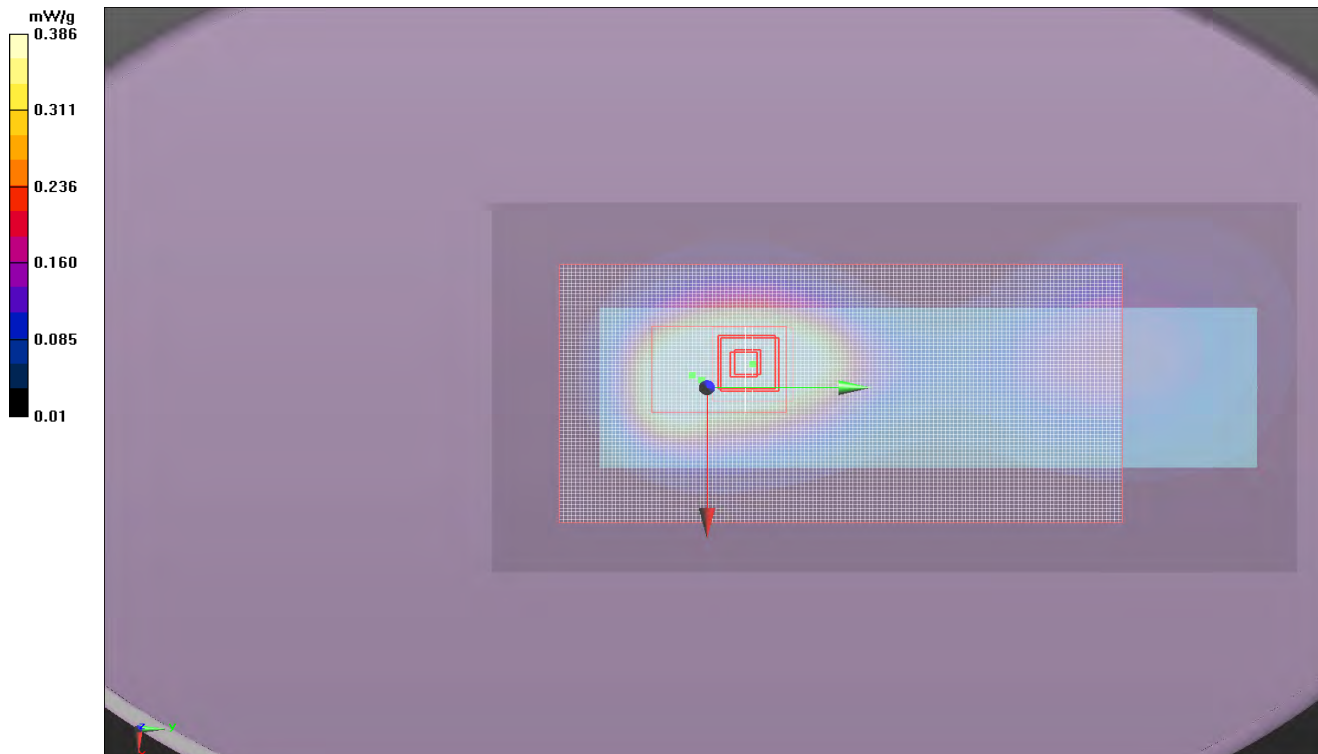

Room Temperature (°C):	22.3	Humidity (%):	41	Test Date:	08/09/11
Liquid Temperature (°C):	21.9	Barometric Pressure (mb):	1018.6	Tested by:	Ethan Schoonover

Body Test 20 8-9-11

DUT: Handheld Computer (C1); Type: 1001CP01S; Serial: 28311047275

Communication System: GPRS and Edge; Communication System Band: GSM 850; Frequency: 836.6 MHz; Communication System PAR: 9.2 dB
 Medium parameters used: $\sigma = 1.0111$ mho/m, $\epsilon_r = 56.5118$; $\rho = 1000$ kg/m³, Medium parameters used (interpolated): $f = 836.6$ MHz; $\sigma = 1.013$ mho/m; $\epsilon_r = 56.502$; $\rho = 1000$ kg/m³
 Phantom section: Flat Section
 Measurement Standard: DASYS5 (IEEE/IEC/ANSI C63.19-2007)

DASY5 Configuration:

Probe: ES3DV3 - SN3246; ConvF(6.1, 6.1, 6.1); Calibrated: 11/11/2010
 Sensor-Surface: 0mm (Fix Surface), Sensor-Surface: 3mm (Mechanical Surface Detection)
 Electronics: DAE4 Sn1237; Calibrated: 11/10/2010
 Phantom: ELI 4.0; Type: QDOVA001BA; Serial: 1096
 Measurement SW: DASY52, Version 52.6 (2); SEMCAD X Version 14.4.4 (2829)

Body/Body - Mid/Z Scan (1x1x21): Measurement grid: dx=20mm, dy=20mm, dz=5mm
 Maximum value of Total (measured) = 14.353 V/m

Body/Body - Mid/Zoom Scan (7x7x7)/Cube 0: Measurement grid: dx=5mm, dy=5mm, dz=5mm
 Reference Value = 17.898 V/m; Power Drift = 0.0081 dB
 Peak SAR (extrapolated) = 0.392 W/kg
SAR(1 g) = 0.262 mW/g; SAR(10 g) = 0.168 mW/g

[Info: Interpolated medium parameters used for SAR evaluation.](#)

Maximum value of SAR (measured) = 0.308 mW/g

Body/Body - Mid/Area scan (71x161x1): Measurement grid: dx=15mm, dy=15mm

[Info: Interpolated medium parameters used for SAR evaluation.](#)

Maximum value of SAR (interpolated) = 0.315 mW/g

Body/Body - Mid/Reference scan (51x101x1): Measurement grid: dx=30mm, dy=30mm

[Info: Interpolated medium parameters used for SAR evaluation.](#)

Maximum value of SAR (interpolated) = 0.324 mW/g

Body/Body - Mid/Zoom Scan 2 (7x7x7)/Cube 0: Measurement grid: dx=5mm, dy=5mm, dz=5mm

Reference Value = 17.898 V/m; Power Drift = -0.03 dB

Peak SAR (extrapolated) = 0.239 W/kg

SAR(1 g) = 0.177 mW/g; SAR(10 g) = 0.125 mW/g

[Info: Interpolated medium parameters used for SAR evaluation.](#)

Maximum value of SAR (measured) = 0.200 mW/g

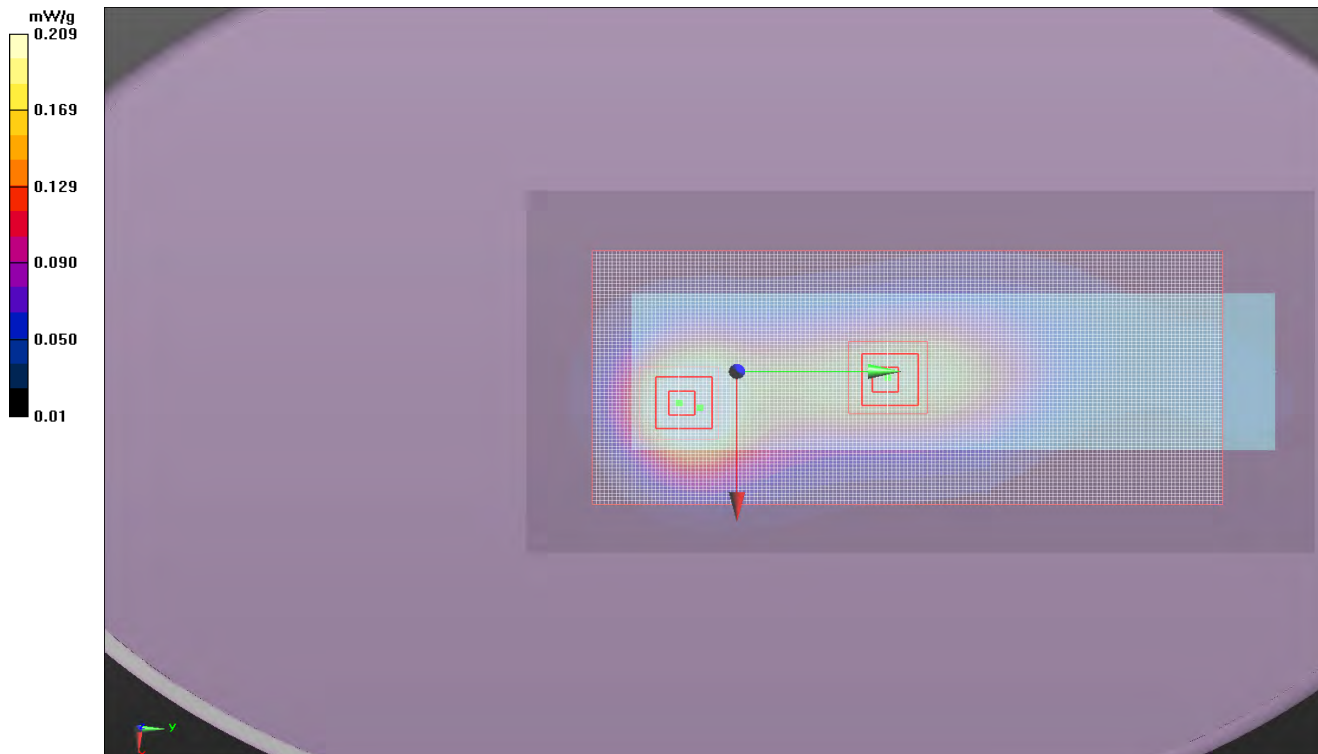

Room Temperature (°C):	24.2	Humidity (%):	47.5	Test Date:	08/11/11
Liquid Temperature (°C):	22.6	Barometric Pressure (mb):	1016.9	Tested by:	Jennifer Herrett

Body Test 21 8-11-11

DUT: Handheld Computer (C1); Type: 1001CP01S; Serial: 28311047275

Communication System: CW; Frequency: 836.6 MHz

Medium parameters used: $\sigma = 0.994564$ mho/m, $\epsilon_r = 54.9855$; $\rho = 1000$ kg/m³, Medium parameters used (interpolated): $f = 836.6$ MHz; $\sigma = 0.996$ mho/m; $\epsilon_r = 54.973$; $\rho = 1000$ kg/m³

Phantom section: Flat Section

Measurement Standard: DASYS5 (IEEE/IEC/ANSI C63.19-2007)

DASY5 Configuration:

Probe: ES3DV3 - SN3246; ConvF(6.1, 6.1, 6.1); Calibrated: 11/11/2010

Sensor-Surface: 0mm (Fix Surface), Sensor-Surface: 3mm (Mechanical Surface Detection)

Electronics: DAE4 Sn1237; Calibrated: 11/10/2010

Phantom: ELI 4.0; Type: QDOVA001BA; Serial: 1096

Measurement SW: DASY52, Version 52.6 (2); SEMCAD X Version 14.4.4 (2829)

Body/Body - Mid/Z Scan (1x1x21): Measurement grid: dx=20mm, dy=20mm, dz=5mm

Maximum value of Total (measured) = 8.939 V/m

Body/Body - Mid/Zoom Scan (7x7x7)/Cube 0: Measurement grid: dx=5mm, dy=5mm, dz=5mm

Reference Value = 11.320 V/m; Power Drift = 0.07 dB

Peak SAR (extrapolated) = 0.140 W/kg

SAR(1 g) = 0.108 mW/g; SAR(10 g) = 0.079 mW/g

[Info: Interpolated medium parameters used for SAR evaluation.](#)

Maximum value of SAR (measured) = 0.120 mW/g

Body/Body - Mid/Reference scan (51x91x1): Measurement grid: dx=30mm, dy=30mm

[Info: Interpolated medium parameters used for SAR evaluation.](#)

Maximum value of SAR (interpolated) = 0.142 mW/g

Body/Body - Mid/Area scan (71x71x1): Measurement grid: dx=15mm, dy=15mm

[Info: Interpolated medium parameters used for SAR evaluation.](#)

Maximum value of SAR (interpolated) = 0.123 mW/g

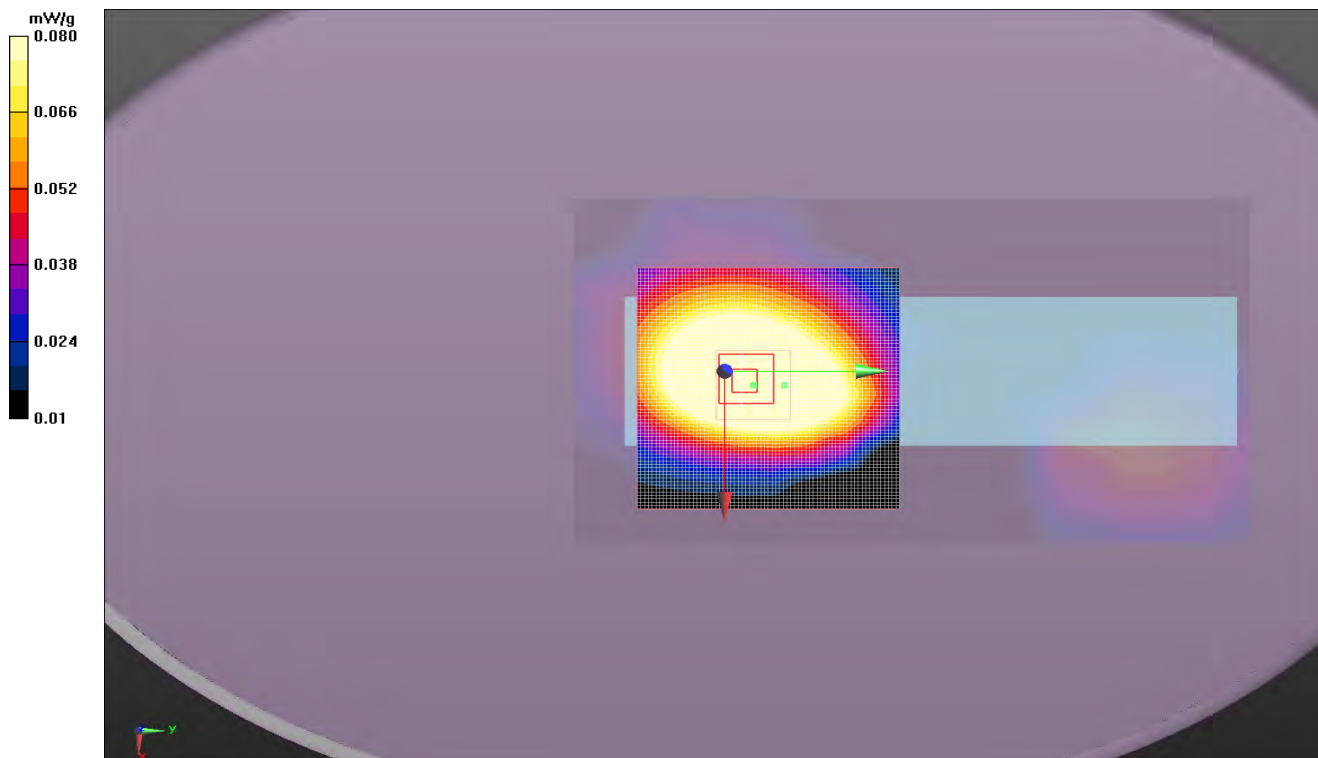

Room Temperature (°C):	24.2	Humidity (%):	47.5	Test Date:	08/11/11
Liquid Temperature (°C):	22.6	Barometric Pressure (mb):	1016.9	Tested by:	Jennifer Herrett

Body Test 22 8-11-11

DUT: Handheld Computer (C1); Type: 1001CP01S; Serial: 28311047275

Communication System: CW; Frequency: 836.6 MHz

Medium parameters used: $\sigma = 0.994564$ mho/m, $\epsilon_r = 54.9855$; $\rho = 1000$ kg/m³, Medium parameters used (interpolated): $f = 836.6$ MHz; $\sigma = 0.996$ mho/m; $\epsilon_r = 54.973$; $\rho = 1000$ kg/m³

Phantom section: Flat Section

Measurement Standard: DASYS (IEEE/IEC/ANSI C63.19-2007)

DASY5 Configuration:

Probe: ES3DV3 - SN3246; ConvF(6.1, 6.1, 6.1); Calibrated: 11/11/2010

Sensor-Surface: 0mm (Fix Surface), Sensor-Surface: 3mm (Mechanical Surface Detection)

Electronics: DAE4 Sn1237; Calibrated: 11/10/2010

Phantom: ELI 4.0; Type: QDOVA001BA; Serial: 1096

Measurement SW: DASY52, Version 52.6 (2); SEMCAD X Version 14.4.4 (2829)

Body/Body - Mid/Z Scan (1x1x21): Measurement grid: dx=20mm, dy=20mm, dz=5mm

Maximum value of Total (measured) = 10.827 V/m

Body/Body - Mid/Zoom Scan (7x7x7)/Cube 0: Measurement grid: dx=5mm, dy=5mm, dz=5mm

Reference Value = 12.814 V/m; Power Drift = 0.11 dB

Peak SAR (extrapolated) = 0.202 W/kg

SAR(1 g) = 0.141 mW/g; SAR(10 g) = 0.092 mW/g

[Info: Interpolated medium parameters used for SAR evaluation.](#)

Maximum value of SAR (measured) = 0.164 mW/g

Body/Body - Mid/Reference scan (51x91x1): Measurement grid: dx=30mm, dy=30mm

[Info: Interpolated medium parameters used for SAR evaluation.](#)

Maximum value of SAR (interpolated) = 0.204 mW/g

Body/Body - Mid/Area scan (71x171x1): Measurement grid: dx=15mm, dy=15mm

[Info: Interpolated medium parameters used for SAR evaluation.](#)

Maximum value of SAR (interpolated) = 0.162 mW/g

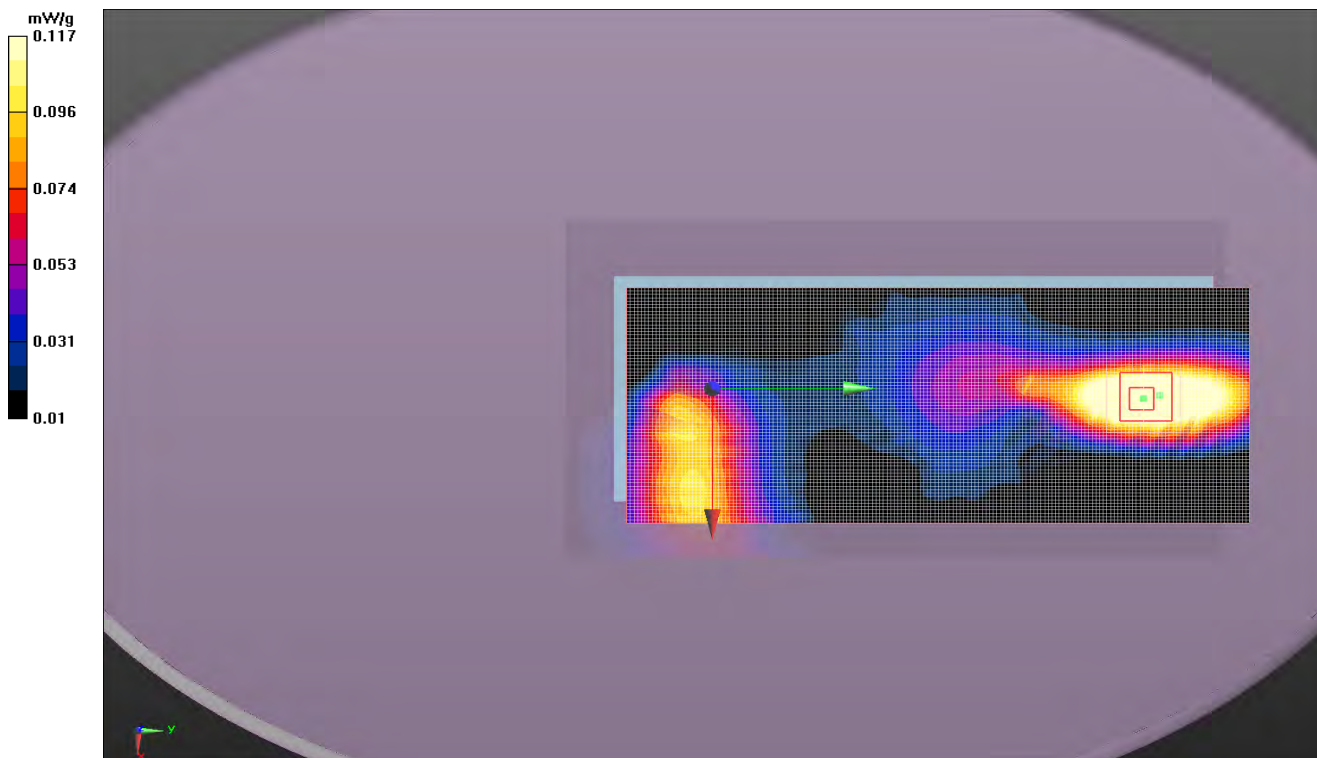

Room Temperature (°C):	24.2	Humidity (%):	45.8	Test Date:	08/11/11
Liquid Temperature (°C):	22.5	Barometric Pressure (mb):	1016.9	Tested by:	Jennifer Herrett

Body Test 23 8-11-11

DUT: Handheld Computer (C1); Type: 1001CP01S; Serial: 28311047275

Communication System: CW; Frequency: 836.6 MHz

Medium parameters used: $\sigma = 0.994564$ mho/m, $\epsilon_r = 54.9855$; $\rho = 1000$ kg/m³, Medium parameters used (interpolated): $f = 836.6$ MHz; $\sigma = 0.996$ mho/m; $\epsilon_r = 54.973$; $\rho = 1000$ kg/m³

Phantom section: Flat Section

Measurement Standard: DASYS (IEEE/IEC/ANSI C63.19-2007)

DASY5 Configuration:

Probe: ES3DV3 - SN3246; ConvF(6.1, 6.1, 6.1); Calibrated: 11/11/2010

Sensor-Surface: 0mm (Fix Surface), Sensor-Surface: 3mm (Mechanical Surface Detection)

Electronics: DAE4 Sn1237; Calibrated: 11/10/2010

Phantom: ELI 4.0; Type: QDOVA001BA; Serial: 1096

Measurement SW: DASY52, Version 52.6 (2); SEMCAD X Version 14.4.4 (2829)

Body/Body - Mid/Z Scan (1x1x21): Measurement grid: dx=20mm, dy=20mm, dz=5mm

Maximum value of Total (measured) = 14.905 V/m

Body/Body - Mid/Zoom Scan (7x7x7)/Cube 0: Measurement grid: dx=5mm, dy=5mm, dz=5mm

Reference Value = 19.783 V/m; Power Drift = 0.02 dB

Peak SAR (extrapolated) = 0.439 W/kg

SAR(1 g) = 0.310 mW/g; SAR(10 g) = 0.203 mW/g

[Info: Interpolated medium parameters used for SAR evaluation.](#)

Maximum value of SAR (measured) = 0.361 mW/g

Body/Body - Mid/Reference scan (51x91x1): Measurement grid: dx=30mm, dy=30mm

[Info: Interpolated medium parameters used for SAR evaluation.](#)

Maximum value of SAR (interpolated) = 0.307 mW/g

Body/Body - Mid/Area scan (71x71x1): Measurement grid: dx=15mm, dy=15mm

[Info: Interpolated medium parameters used for SAR evaluation.](#)

Maximum value of SAR (interpolated) = 0.367 mW/g

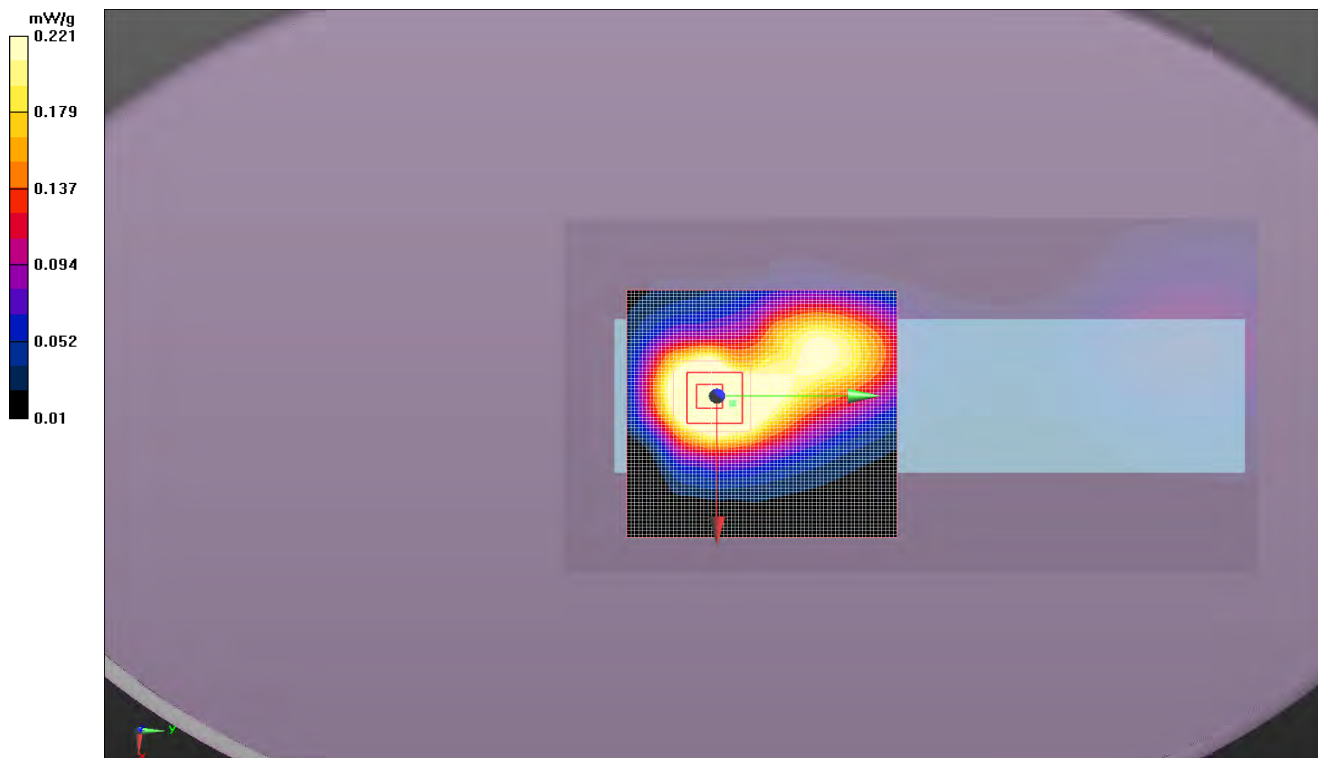

Room Temperature (°C):	24.2	Humidity (%):	45.8	Test Date:	08/11/11
Liquid Temperature (°C):	22.5	Barometric Pressure (mb):	1016.9	Tested by:	Jennifer Herrett

Body Test 24 8-11-11

DUT: Handheld Computer (C1); Type: 1001CP01S; Serial: 28311047275

Communication System: CW; Frequency: 836.6 MHz

Medium parameters used: $\sigma = 0.994564$ mho/m, $\epsilon_r = 54.9855$; $\rho = 1000$ kg/m³, Medium parameters used (interpolated): $f = 836.6$ MHz; $\sigma = 0.996$ mho/m; $\epsilon_r = 54.973$; $\rho = 1000$ kg/m³

Phantom section: Flat Section

Measurement Standard: DASYS (IEEE/IEC/ANSI C63.19-2007)

DASY5 Configuration:

Probe: ES3DV3 - SN3246; ConvF(6.1, 6.1, 6.1); Calibrated: 11/11/2010

Sensor-Surface: 0mm (Fix Surface), Sensor-Surface: 3mm (Mechanical Surface Detection)

Electronics: DAE4 Sn1237; Calibrated: 11/10/2010

Phantom: ELI 4.0; Type: QDOVA001BA; Serial: 1096

Measurement SW: DASY52, Version 52.6 (2); SEMCAD X Version 14.4.4 (2829)

Body/Body - Mid/Z Scan (1x1x21): Measurement grid: dx=20mm, dy=20mm, dz=5mm

Maximum value of Total (measured) = 15.386 V/m

Body/Body - Mid/Zoom Scan (7x7x7)/Cube 0: Measurement grid: dx=5mm, dy=5mm, dz=5mm

Reference Value = 19.522 V/m; Power Drift = -0.02 dB

Peak SAR (extrapolated) = 0.503 W/kg

SAR(1 g) = 0.343 mW/g; SAR(10 g) = 0.216 mW/g

[Info: Interpolated medium parameters used for SAR evaluation.](#)

Maximum value of SAR (measured) = 0.404 mW/g

Body/Body - Mid/Reference scan (41x111x1): Measurement grid: dx=30mm, dy=30mm

[Info: Interpolated medium parameters used for SAR evaluation.](#)

Maximum value of SAR (interpolated) = 0.410 mW/g

Body/Body - Mid/Area scan (71x71x1): Measurement grid: dx=15mm, dy=15mm

[Info: Interpolated medium parameters used for SAR evaluation.](#)

Maximum value of SAR (interpolated) = 0.407 mW/g

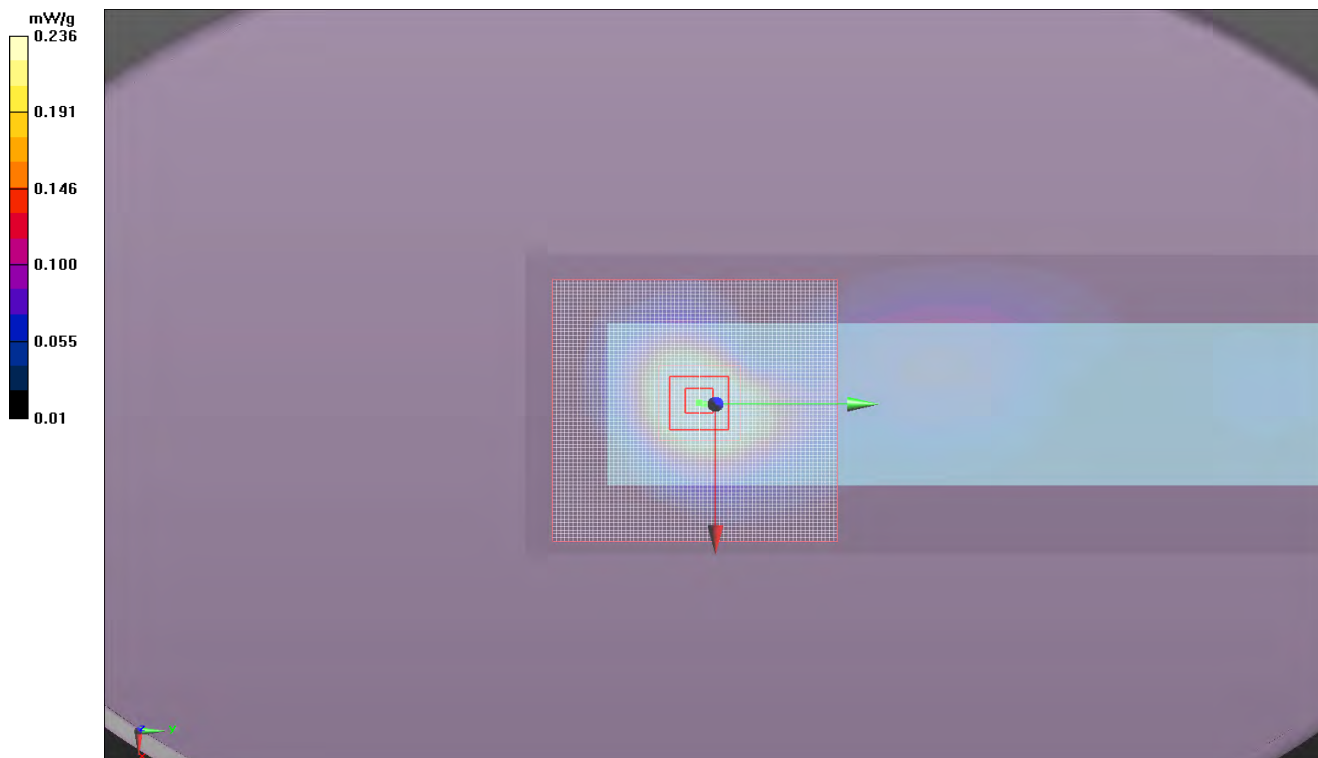

EMC

SAR TEST DATA

Room Temperature (°C):	23	Humidity (%):	45.5	Test Date:	08/09/11
Liquid Temperature (°C):	21.1	Barometric Pressure (mb):	1018.6	Tested by:	Ethan Schoonover

Body Test 19 8-9-11

DUT: Handheld Computer (C1); Type: 1001CP01S; Serial: 28311047275

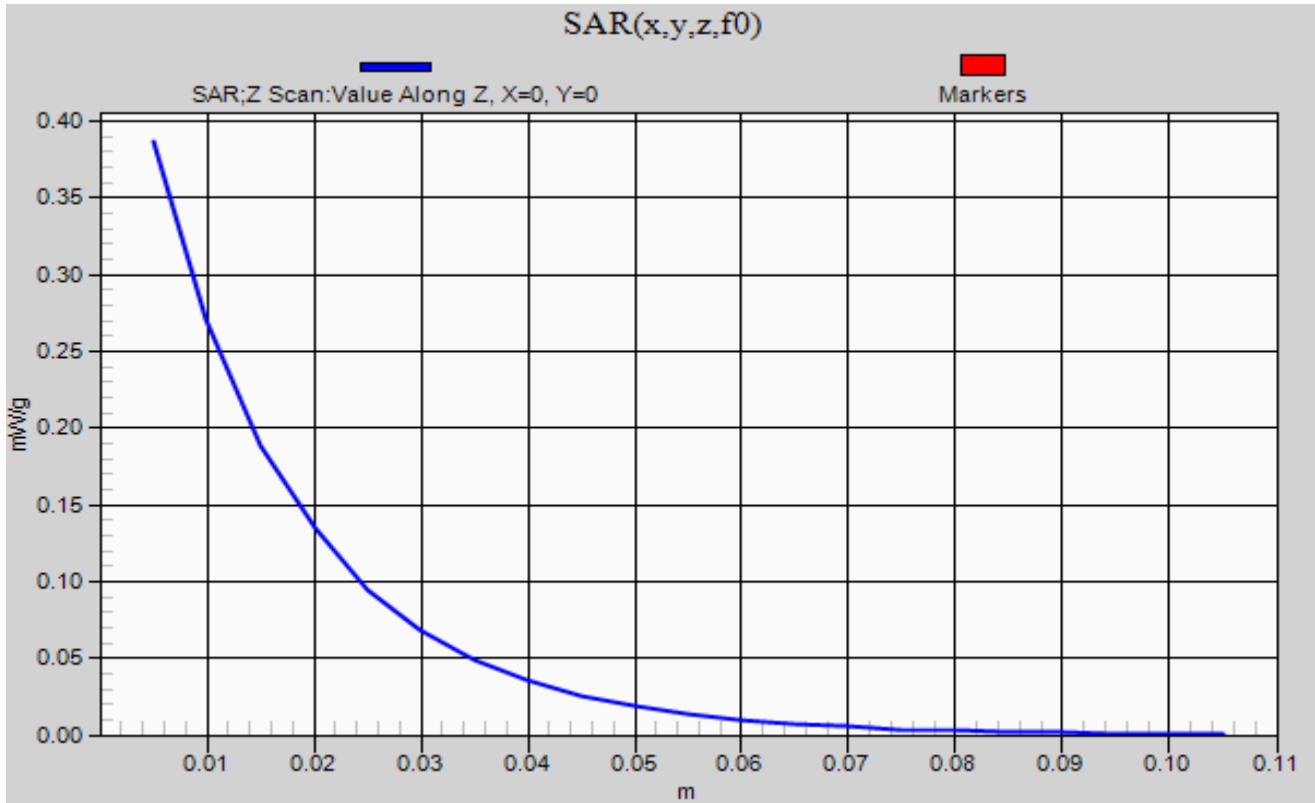

SAR TEST DATA

EUT: 1001CP01S	Work Order: ITRM0248
Serial Number: 28311047275	Date: See Data Sheets
Customer: Intermec Technologies Corporation	Temperature: See Data Sheets
Attendees: None	Humidity: See Data Sheets
Project: None	Barometric Pres.: See Data Sheets
Tested by: Jennifer Herrett and Ethan Schoonover	Job Site: EV08
TEST SPECIFICATIONS	
FCC 2.1093:2011	Test Method FCC OET 65C:2001 IEEE Std 1528:2003 FCC KDB 447498 D01 v04 FCC KDB 941225 D01 v02 FCC KDB 648474 D01 V01r05
Health Safety Code 6:2009	RSS-102, Issue 4:2010
COMMENTS	
None	
DEVIATIONS FROM TEST STANDARD	
No Deviations	
Configuration #	9
Signature <i>Jennifer Herrett</i>	

Test Configuration	Frequency Band	Body-Worn Accessory	Transmit Frequency	Transmit Channel	Transmit Mode	Data Rate (Mbps)	Audio Accessory	EUT Position	Start Power (Conducted)	SAR Drift During Test (dB)	1g SAR Level	Test #
Head	PCS	None	1880	661	E-GPRS / 1 slot	GMSK (MCS-4)	Left	Cheek	32.69	0.23	0.012	41
								Tilt	32.69	0.9	0.009	42
								Cheek	32.69	0.15	0.028	43
								Tilt	32.69	0.23	0.022	44
				9400	WCDMA / Test Loop 1	12.2 kbps RMC	Left	Cheek	24.54	0.11	0.196	45
								Tilt	24.54	0.15	0.151	46
								Cheek	24.54	0.0039	0.371	47
								Tilt	24.54	0.29	0.278	48

EMC

SAR TEST DATA

Room Temperature (°C):	23.7	Humidity (%):	46.5	Test Date:	08/10/11
Liquid Temperature (°C):	21.7	Barometric Pressure (mb):	1017	Tested by:	Ethan Schoonover

Head Test 41 8-10-11

DUT: Handheld Computer (C1); Type: 1001CP01S; Serial: 28311047275

Communication System: GPRS and Edge; Communication System Band: PCS 1900; Frequency: 1880 MHz; Communication System PAR: 9.2 dB
 Medium parameters used (interpolated): $f = 1880$ MHz; $\sigma = 1.376$ mho/m; $\epsilon_r = 39.948$; $\rho = 1000$ kg/m³, Medium parameters used: $\sigma = 1.37132$ mho/m, $\epsilon_r = 39.9696$; $\rho = 1000$ kg/m³
 Phantom section: Left Section
 Measurement Standard: DASYS5 (IEEE/IEC/ANSI C63.19-2007)

DASY5 Configuration:

Probe: ES3DV3 - SN3246; ConvF(5.02, 5.02, 5.02); Calibrated: 11/11/2010
 Sensor-Surface: 3mm (Mechanical Surface Detection), Sensor-Surface: 0mm (Fix Surface)
 Electronics: DAE4 Sn1237; Calibrated: 11/10/2010
 Phantom: SAM with CRP; Type: SAM; Serial: 1598
 Measurement SW: DASY52, Version 52.6 (2); SEMCAD X Version 14.4.4 (2829)

Head - Right/Cheek - Mid/Reference scan (41x91x1): Measurement grid: dx=30mm, dy=30mm

[Info: Interpolated medium parameters used for SAR evaluation.](#)

Maximum value of SAR (interpolated) = 0.019 mW/g

Head - Right/Cheek - Mid/Z Scan (1x1x21): Measurement grid: dx=20mm, dy=20mm, dz=5mm

Maximum value of Total (measured) = 2.588 V/m

Head - Right/Cheek - Mid/Zoom Scan (7x7x7)/Cube 0: Measurement grid: dx=5mm, dy=5mm, dz=5mm

Reference Value = 3.293 V/m; Power Drift = 0.23 dB

Peak SAR (extrapolated) = 0.039 W/kg

SAR(1 g) = 0.012 mW/g; SAR(10 g) = 0.00562 mW/g

[Info: Interpolated medium parameters used for SAR evaluation.](#)

Maximum value of SAR (measured) = 0.018 mW/g

Head - Right/Cheek - Mid/Area scan (71x71x1): Measurement grid: dx=15mm, dy=15mm

[Info: Interpolated medium parameters used for SAR evaluation.](#)

Maximum value of SAR (interpolated) = 0.032 mW/g

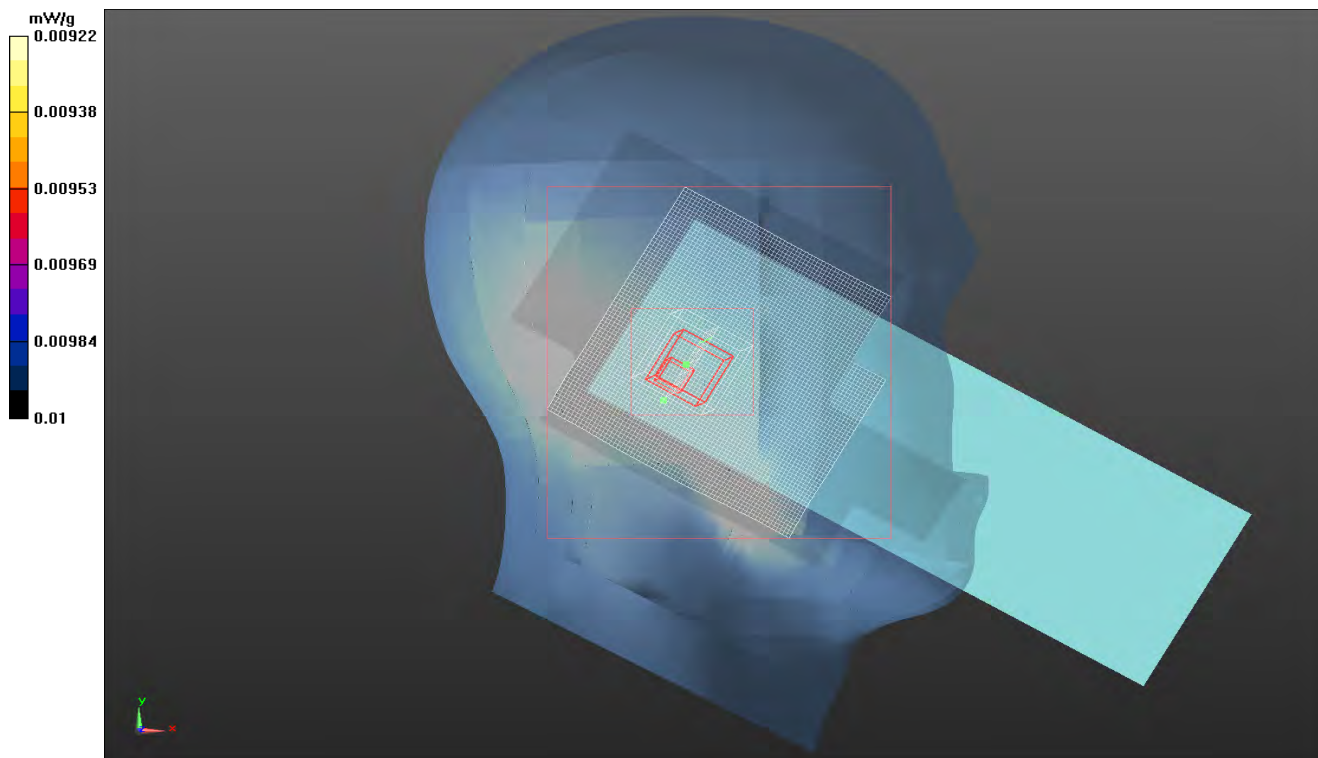

Room Temperature (°C):	23.6	Humidity (%):	42.4	Test Date:	08/10/11
Liquid Temperature (°C):	21.7	Barometric Pressure (mb):	1017	Tested by:	Ethan Schoonover

Head Test 42 8-10-11

DUT: Handheld Computer (C1); Type: 1001CP01S; Serial: 28311047275

Communication System: GPRS and Edge; Communication System Band: PCS 1900; Frequency: 1880 MHz; Communication System PAR: 9.2 dB
 Medium parameters used (interpolated): $f = 1880$ MHz; $\sigma = 1.376$ mho/m; $\epsilon_r = 39.948$; $\rho = 1000$ kg/m³, Medium parameters used: $\sigma = 1.37132$ mho/m, $\epsilon_r = 39.9696$; $\rho = 1000$ kg/m³
 Phantom section: Left Section
 Measurement Standard: DASYS5 (IEEE/IEC/ANSI C63.19-2007)

DASY5 Configuration:

Probe: ES3DV3 - SN3246; ConvF(5.02, 5.02, 5.02); Calibrated: 11/11/2010
 Sensor-Surface: 3mm (Mechanical Surface Detection), Sensor-Surface: 0mm (Fix Surface)
 Electronics: DAE4 Sn1237; Calibrated: 11/10/2010
 Phantom: SAM with CRP; Type: SAM; Serial: 1598
 Measurement SW: DASYS2, Version 52.6 (2); SEMCAD X Version 14.4.4 (2829)

Head - Right/Tilt - Mid/Zoom Scan (11x8x7)/Cube 0: Measurement grid: dx=5mm, dy=5mm, dz=5mm

Reference Value = 2.708 V/m; Power Drift = 0.90 dB

Peak SAR (extrapolated) = 0.025 W/kg

SAR(1 g) = 0.00939 mW/g; SAR(10 g) = 0.00464 mW/g

[Info: Interpolated medium parameters used for SAR evaluation.](#)

Maximum value of SAR (measured) = 0.014 mW/g

Head - Right/Tilt - Mid/Z Scan (1x1x21): Measurement grid: dx=20mm, dy=20mm, dz=5mm

Maximum value of Total (measured) = 2.432 V/m

Head - Right/Tilt - Mid/Reference scan (41x91x1): Measurement grid: dx=30mm, dy=30mm

[Info: Interpolated medium parameters used for SAR evaluation.](#)

Maximum value of SAR (interpolated) = 0.012 mW/g

Head - Right/Tilt - Mid/Area scan (71x71x1): Measurement grid: dx=15mm, dy=15mm

[Info: Interpolated medium parameters used for SAR evaluation.](#)

Maximum value of SAR (interpolated) = 0.023 mW/g

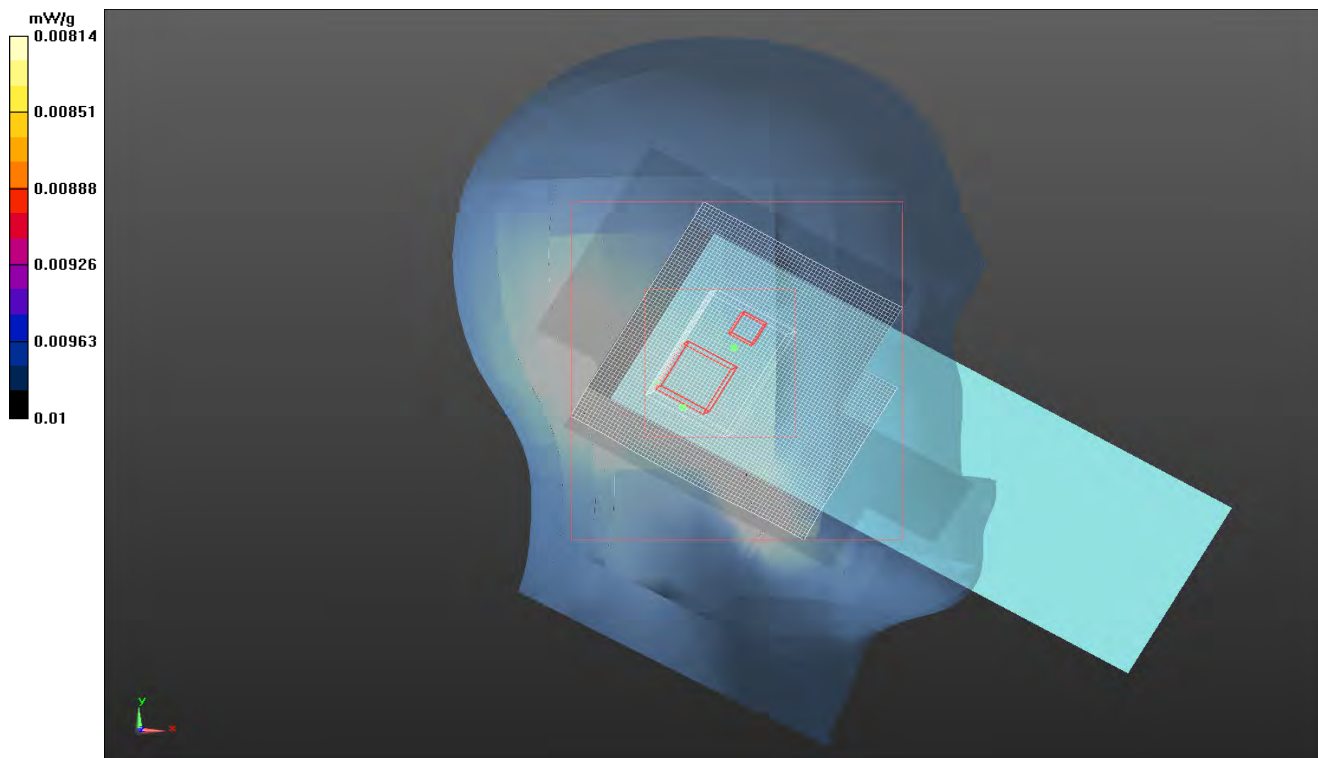

Room Temperature (°C):	25.3	Humidity (%):	46.4	Test Date:	08/10/11
Liquid Temperature (°C):	22.3	Barometric Pressure (mb):	1017	Tested by:	Ethan Schoonover

Head Test 43 8-10-11

DUT: Handheld Computer (C1); Type: 1001CP01S; Serial: 28311047275

Communication System: GPRS and Edge; Communication System Band: PCS 1900; Frequency: 1880 MHz; Communication System PAR: 9.2 dB
 Medium parameters used (interpolated): $f = 1880$ MHz; $\sigma = 1.376$ mho/m; $\epsilon_r = 39.948$; $\rho = 1000$ kg/m³, Medium parameters used: $\sigma = 1.37132$ mho/m, $\epsilon_r = 39.9696$; $\rho = 1000$ kg/m³
 Phantom section: Right Section
 Measurement Standard: DASYS5 (IEEE/IEC/ANSI C63.19-2007)

DASY5 Configuration:

Probe: ES3DV3 - SN3246; ConvF(5.02, 5.02, 5.02); Calibrated: 11/11/2010
 Sensor-Surface: 3mm (Mechanical Surface Detection), Sensor-Surface: 0mm (Fix Surface)
 Electronics: DAE4 Sn1237; Calibrated: 11/10/2010
 Phantom: SAM with CRP; Type: SAM; Serial: 1598
 Measurement SW: DASYS2, Version 52.6 (2); SEMCAD X Version 14.4.4 (2829)

Head - Right/Cheek - Mid/Reference scan (41x91x1): Measurement grid: dx=30mm, dy=30mm

[Info: Interpolated medium parameters used for SAR evaluation.](#)

Maximum value of SAR (interpolated) = 0.051 mW/g

Head - Right/Cheek - Mid/Z Scan (1x1x21): Measurement grid: dx=20mm, dy=20mm, dz=5mm

Maximum value of Total (measured) = 3.786 V/m

Head - Right/Cheek - Mid/Zoom Scan (8x8x7)/Cube 0: Measurement grid: dx=5mm, dy=5mm, dz=5mm

Reference Value = 4.714 V/m; Power Drift = 0.15 dB

Peak SAR (extrapolated) = 0.091 W/kg

SAR(1 g) = 0.028 mW/g; SAR(10 g) = 0.017 mW/g

[Info: Interpolated medium parameters used for SAR evaluation.](#)

Maximum value of SAR (measured) = 0.033 mW/g

Head - Right/Cheek - Mid/Area scan (71x71x1): Measurement grid: dx=15mm, dy=15mm

[Info: Interpolated medium parameters used for SAR evaluation.](#)

Maximum value of SAR (interpolated) = 0.052 mW/g

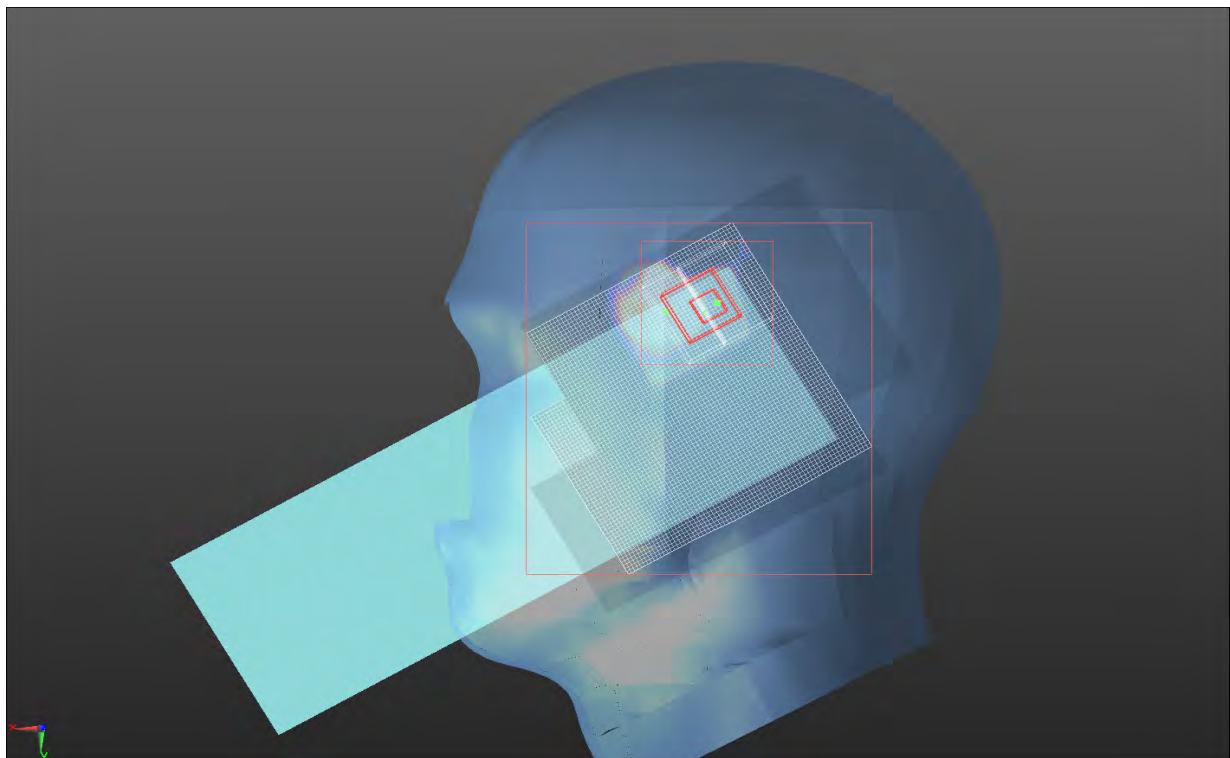
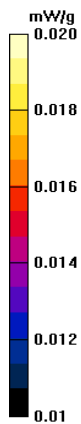

Room Temperature (°C):	24.4	Humidity (%):	41.2	Test Date:	08/10/11
Liquid Temperature (°C):	22.2	Barometric Pressure (mb):	1017	Tested by:	Ethan Schoonover

Head Test 44 8-10-11

DUT: Handheld Computer (C1); Type: 1001CP01S; Serial: 28311047275

Communication System: GPRS and Edge; Communication System Band: PCS 1900; Frequency: 1880 MHz; Communication System PAR: 9.2 dB
 Medium parameters used (interpolated): $f = 1880$ MHz; $\sigma = 1.376$ mho/m; $\epsilon_r = 39.948$; $\rho = 1000$ kg/m³, Medium parameters used: $\sigma = 1.37132$ mho/m, $\epsilon_r = 39.9696$; $\rho = 1000$ kg/m³
 Phantom section: Right Section
 Measurement Standard: DASYS (IEEE/IEC/ANSI C63.19-2007)

DASY5 Configuration:

Probe: ES3DV3 - SN3246; ConvF(5.02, 5.02, 5.02); Calibrated: 11/11/2010
 Sensor-Surface: 3mm (Mechanical Surface Detection), Sensor-Surface: 0mm (Fix Surface)
 Electronics: DAE4 Sn1237; Calibrated: 11/10/2010
 Phantom: SAM with CRP; Type: SAM; Serial: 1598
 Measurement SW: DASYS2, Version 52.6 (2); SEMCAD X Version 14.4.4 (2829)

Head - Right/Tilt - Mid/Zoom Scan (8x8x7)/Cube 0: Measurement grid: dx=5mm, dy=5mm, dz=5mm

Reference Value = 3.934 V/m; Power Drift = 0.23 dB

Peak SAR (extrapolated) = 0.050 W/kg

SAR(1 g) = 0.022 mW/g; SAR(10 g) = 0.011 mW/g

[Info: Interpolated medium parameters used for SAR evaluation.](#)

Maximum value of SAR (measured) = 0.025 mW/g

Head - Right/Tilt - Mid/Z Scan (1x1x21): Measurement grid: dx=20mm, dy=20mm, dz=5mm

Maximum value of Total (measured) = 3.205 V/m

Head - Right/Tilt - Mid/Reference scan (41x91x1): Measurement grid: dx=30mm, dy=30mm

[Info: Interpolated medium parameters used for SAR evaluation.](#)

Maximum value of SAR (interpolated) = 0.00634 mW/g

Head - Right/Tilt - Mid/Area scan (71x71x1): Measurement grid: dx=15mm, dy=15mm

[Info: Interpolated medium parameters used for SAR evaluation.](#)

Maximum value of SAR (interpolated) = 0.041 mW/g

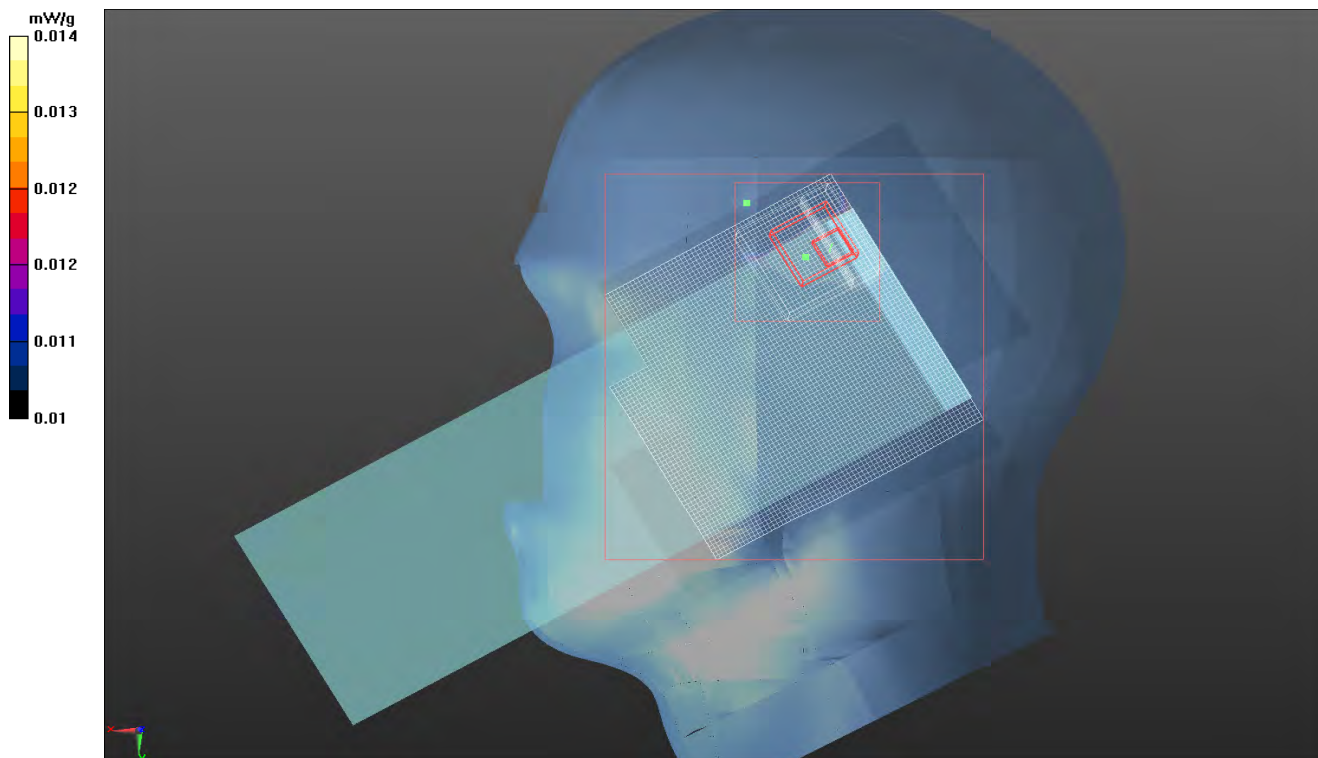

EMC

SAR TEST DATA

Room Temperature (°C):	22.4	Humidity (%):	40.4	Test Date:	08/12/11
Liquid Temperature (°C):	22	Barometric Pressure (mb):	1016.7	Tested by:	Jennifer Herrett

Head Test 45 8-12-11

DUT: Handheld Computer (C1); Type: 1001CP01S; Serial: 28311047275

Communication System: CW; Frequency: 1880 MHz

Medium parameters used (interpolated): $f = 1880$ MHz; $\sigma = 1.366$ mho/m; $\epsilon_r = 39.864$; $\rho = 1000$ kg/m³, Medium parameters used: $\sigma = 1.361$ mho/m, $\epsilon_r = 39.8843$; $\rho = 1000$ kg/m³

Phantom section: Left Section

Measurement Standard: DASYS5 (IEEE/IEC/ANSI C63.19-2007)

DASY5 Configuration:

Probe: ES3DV3 - SN3246; ConvF(5.02, 5.02, 5.02); Calibrated: 11/11/2010

Sensor-Surface: 3mm (Mechanical Surface Detection), Sensor-Surface: 0mm (Fix Surface)

Electronics: DAE4 Sn1237; Calibrated: 11/10/2010

Phantom: SAM with CRP; Type: SAM; Serial: 1598

Measurement SW: DASY52, Version 52.6 (2); SEMCAD X Version 14.4.4 (2829)

Head - Left/Cheek - Mid/Zoom Scan (7x7x7)/Cube 0: Measurement grid: dx=5mm, dy=5mm, dz=5mm

Reference Value = 13.350 V/m; Power Drift = 0.11 dB

Peak SAR (extrapolated) = 0.342 W/kg

SAR(1 g) = 0.196 mW/g; SAR(10 g) = 0.123 mW/g

[Info: Interpolated medium parameters used for SAR evaluation.](#)

Maximum value of SAR (measured) = 0.234 mW/g

Head - Left/Cheek - Mid/Area scan (71x71x1): Measurement grid: dx=15mm, dy=15mm

[Info: Interpolated medium parameters used for SAR evaluation.](#)

Maximum value of SAR (interpolated) = 0.246 mW/g

Head - Left/Cheek - Mid/Z Scan (1x1x21): Measurement grid: dx=20mm, dy=20mm, dz=5mm

Maximum value of Total (measured) = 10.291 V/m

Head - Left/Cheek - Mid/Reference scan (51x91x1): Measurement grid: dx=30mm, dy=30mm

[Info: Interpolated medium parameters used for SAR evaluation.](#)

Maximum value of SAR (interpolated) = 0.317 mW/g

Head - Left/Cheek - Mid/Zoom Scan 2 (7x7x7)/Cube 0: Measurement grid: dx=5mm, dy=5mm, dz=5mm

Reference Value = 13.350 V/m; Power Drift = 0.13 dB

Peak SAR (extrapolated) = 0.294 W/kg

SAR(1 g) = 0.179 mW/g; SAR(10 g) = 0.101 mW/g

[Info: Interpolated medium parameters used for SAR evaluation.](#)

Maximum value of SAR (measured) = 0.215 mW/g

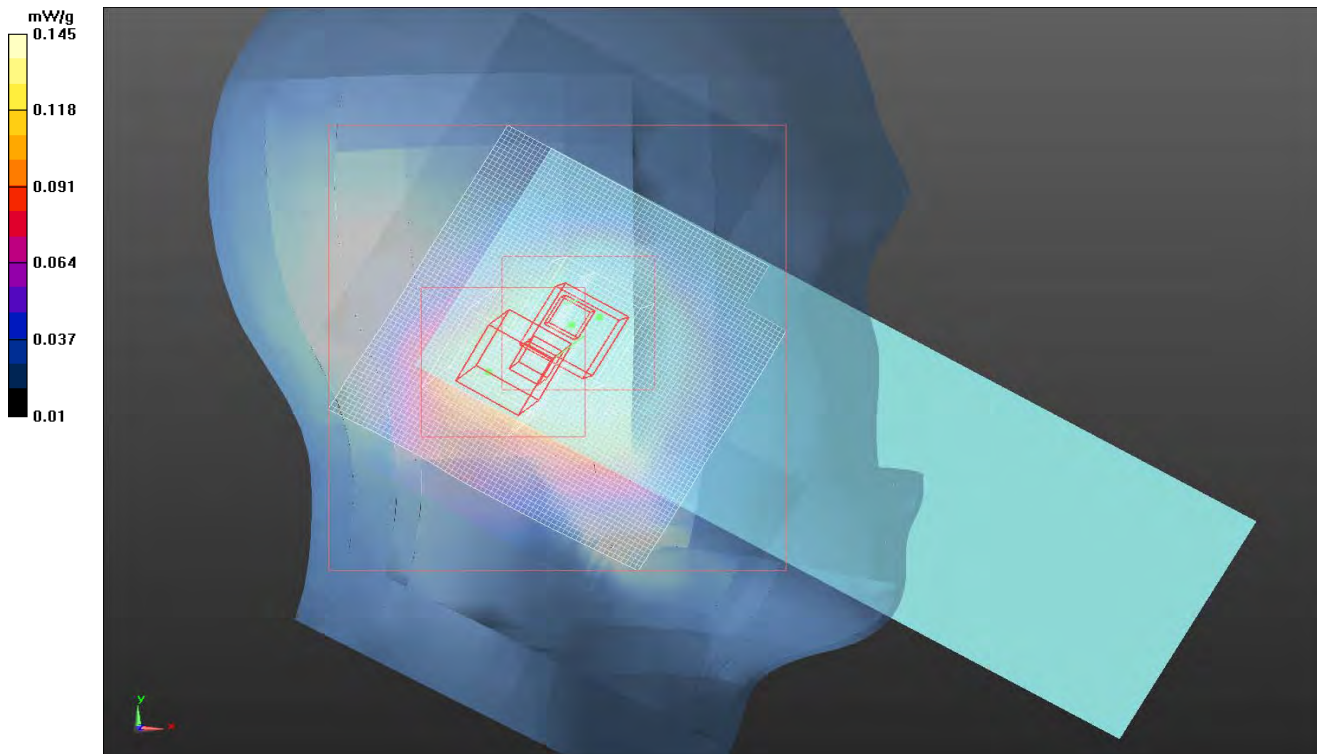

Room Temperature (°C):	22.4	Humidity (%):	40.4	Test Date:	08/12/11
Liquid Temperature (°C):	22	Barometric Pressure (mb):	1016.7	Tested by:	Jennifer Herrett

Head Test 46 8-12-11

DUT: Handheld Computer (C1); Type: 1001CP01S; Serial: 28311047275

Communication System: CW; Frequency: 1880 MHz

Medium parameters used (interpolated): $f = 1880$ MHz; $\sigma = 1.366$ mho/m; $\epsilon_r = 39.864$; $\rho = 1000$ kg/m³, Medium parameters used: $\sigma = 1.361$ mho/m, $\epsilon_r = 39.8843$; $\rho = 1000$ kg/m³

Phantom section: Left Section

Measurement Standard: DASYS5 (IEEE/IEC/ANSI C63.19-2007)

DASY5 Configuration:

Probe: ES3DV3 - SN3246; ConvF(5.02, 5.02, 5.02); Calibrated: 11/11/2010

Sensor-Surface: 3mm (Mechanical Surface Detection), Sensor-Surface: 0mm (Fix Surface)

Electronics: DAE4 Sn1237; Calibrated: 11/10/2010

Phantom: SAM with CRP; Type: SAM; Serial: 1598

Measurement SW: DASYS2, Version 52.6 (2); SEMCAD X Version 14.4.4 (2829)

Head - Left/Tilt - Mid/Zoom Scan (7x7x7)/Cube 0: Measurement grid: dx=5mm, dy=5mm, dz=5mm

Reference Value = 10.759 V/m; Power Drift = 0.11 dB

Peak SAR (extrapolated) = 0.251 W/kg

SAR(1 g) = 0.147 mW/g; SAR(10 g) = 0.088 mW/g

[Info: Interpolated medium parameters used for SAR evaluation.](#)

Maximum value of SAR (measured) = 0.176 mW/g

Head - Left/Tilt - Mid/Area scan (71x71x1): Measurement grid: dx=15mm, dy=15mm

[Info: Interpolated medium parameters used for SAR evaluation.](#)

Maximum value of SAR (interpolated) = 0.165 mW/g

Head - Left/Tilt - Mid/Z Scan (1x1x21): Measurement grid: dx=20mm, dy=20mm, dz=5mm

Maximum value of Total (measured) = 8.785 V/m

Head - Left/Tilt - Mid/Reference scan (51x91x1): Measurement grid: dx=30mm, dy=30mm

[Info: Interpolated medium parameters used for SAR evaluation.](#)

Maximum value of SAR (interpolated) = 0.239 mW/g

Head - Left/Tilt - Mid/Zoom Scan 2 (13x11x7)/Cube 0: Measurement grid: dx=5mm, dy=5mm, dz=5mm

Reference Value = 10.759 V/m; Power Drift = 0.15 dB

Peak SAR (extrapolated) = 0.254 W/kg

SAR(1 g) = 0.151 mW/g; SAR(10 g) = 0.091 mW/g

[Info: Interpolated medium parameters used for SAR evaluation.](#)

Maximum value of SAR (measured) = 0.178 mW/g

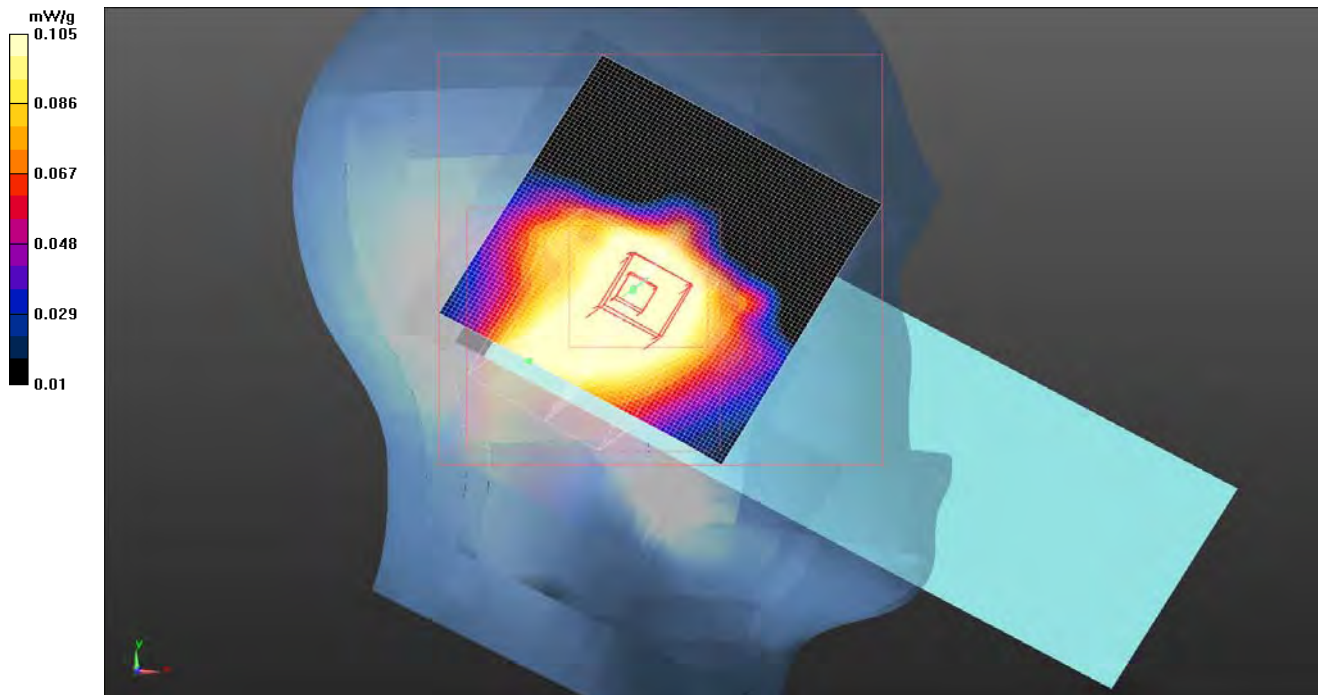

EMC

SAR TEST DATA

Room Temperature (°C):	21.6	Humidity (%):	42.9	Test Date:	08/12/11
Liquid Temperature (°C):	21	Barometric Pressure (mb):	1016.7	Tested by:	Jennifer Herrett

Head Test 47 8-12-11

DUT: Handheld Computer (C1); Type: 1001CP01S; Serial: 28311047275

Communication System: CW Frequency: 1880 MHz

Medium parameters used (interpolated): $f = 1880$ MHz; $\sigma = 1.366$ mho/m; $\epsilon_r = 39.864$; $\rho = 1000$ kg/m³, Medium parameters used: $\sigma = 1.361$ mho/m, $\epsilon_r = 39.8843$; $\rho = 1000$ kg/m³

Phantom section: Right Section

Measurement Standard: DASYS5 (IEEE/IEC/ANSI C63.19-2007)

DASY5 Configuration:

Probe: ES3DV3 - SN3246; ConvF(5.02, 5.02, 5.02); Calibrated: 11/11/2010

Sensor-Surface: 3mm (Mechanical Surface Detection), Sensor-Surface: 0mm (Fix Surface)

Electronics: DAE4 Sn1237; Calibrated: 11/10/2010

Phantom: SAM with CRP; Type: SAM; Serial: 1598

Measurement SW: DASY52, Version 52.6 (2); SEMCAD X Version 14.4.4 (2829)

Head - Right/Cheek - Mid/Reference scan (51x91x1): Measurement grid: dx=30mm, dy=30mm

[Info: Interpolated medium parameters used for SAR evaluation.](#)

Maximum value of SAR (interpolated) = 0.377 mW/g

Head - Right/Cheek - Mid/Z Scan (1x1x21): Measurement grid: dx=20mm, dy=20mm, dz=5mm

Maximum value of Total (measured) = 14.067 V/m

Head - Right/Cheek - Mid/Zoom Scan (7x7x7)/Cube 0: Measurement grid: dx=5mm, dy=5mm, dz=5mm

Reference Value = 16.785 V/m; Power Drift = 0.0039 dB

Peak SAR (extrapolated) = 0.643 W/kg

SAR(1 g) = 0.371 mW/g; SAR(10 g) = 0.214 mW/g

[Info: Interpolated medium parameters used for SAR evaluation.](#)

Maximum value of SAR (measured) = 0.456 mW/g

Head - Right/Cheek - Mid/Area scan (71x71x1): Measurement grid: dx=15mm, dy=15mm

[Info: Interpolated medium parameters used for SAR evaluation.](#)

Maximum value of SAR (interpolated) = 0.430 mW/g

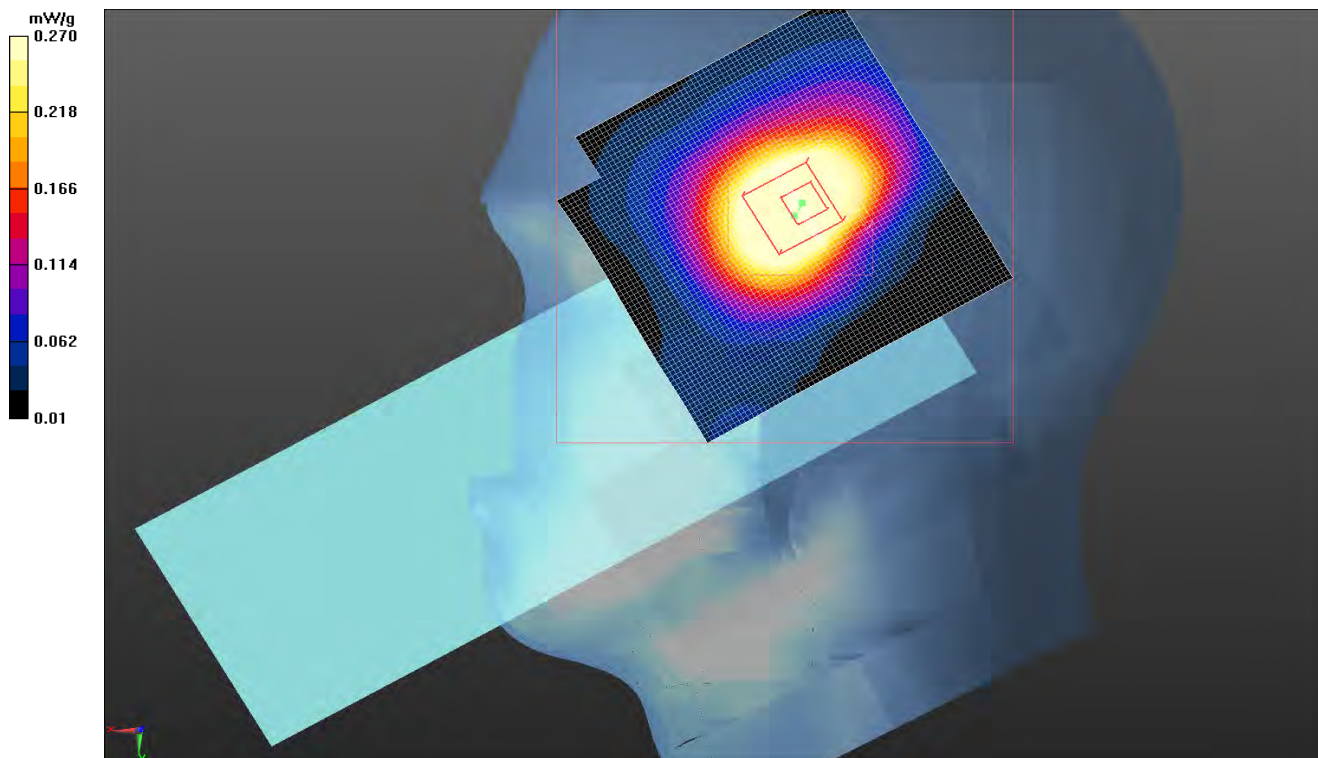

Room Temperature (°C):	21.6	Humidity (%):	42.9	Test Date:	08/12/11
Liquid Temperature (°C):	21	Barometric Pressure (mb):	1016.7	Tested by:	Jennifer Herrett

Head Test 48 8-12-11

DUT: Handheld Computer (C1); Type: 1001CP01S; Serial: 28311047275

Communication System: CW; Frequency: 1880 MHz

Medium parameters used (interpolated): $f = 1880$ MHz; $\sigma = 1.366$ mho/m; $\epsilon_r = 39.864$; $\rho = 1000$ kg/m³, Medium parameters used: $\sigma = 1.361$ mho/m, $\epsilon_r = 39.8843$; $\rho = 1000$ kg/m³

Phantom section: Right Section

Measurement Standard: DASYS (IEEE/IEC/ANSI C63.19-2007)

DASY5 Configuration:

Probe: ES3DV3 - SN3246; ConvF(5.02, 5.02, 5.02); Calibrated: 11/11/2010

Sensor-Surface: 3mm (Mechanical Surface Detection), Sensor-Surface: 0mm (Fix Surface)

Electronics: DAE4 Sn1237; Calibrated: 11/10/2010

Phantom: SAM with CRP; Type: SAM; Serial: 1598

Measurement SW: DASY52, Version 52.6 (2); SEMCAD X Version 14.4.4 (2829)

Head - Right/Tilt - Mid/Zoom Scan (7x7x7)/Cube 0: Measurement grid: dx=5mm, dy=5mm, dz=5mm

Reference Value = 14.399 V/m; Power Drift = 0.29 dB

Peak SAR (extrapolated) = 0.508 W/kg

SAR(1 g) = 0.278 mW/g; SAR(10 g) = 0.153 mW/g

[Info: Interpolated medium parameters used for SAR evaluation.](#)

Maximum value of SAR (measured) = 0.343 mW/g

Head - Right/Tilt - Mid/Z Scan (1x1x21): Measurement grid: dx=20mm, dy=20mm, dz=5mm

Maximum value of Total (measured) = 12.140 V/m

Head - Right/Tilt - Mid/Reference scan (51x91x1): Measurement grid: dx=30mm, dy=30mm

[Info: Interpolated medium parameters used for SAR evaluation.](#)

Maximum value of SAR (interpolated) = 0.218 mW/g

Head - Right/Tilt - Mid/Area scan (71x71x1): Measurement grid: dx=15mm, dy=15mm

[Info: Interpolated medium parameters used for SAR evaluation.](#)

Maximum value of SAR (interpolated) = 0.290 mW/g

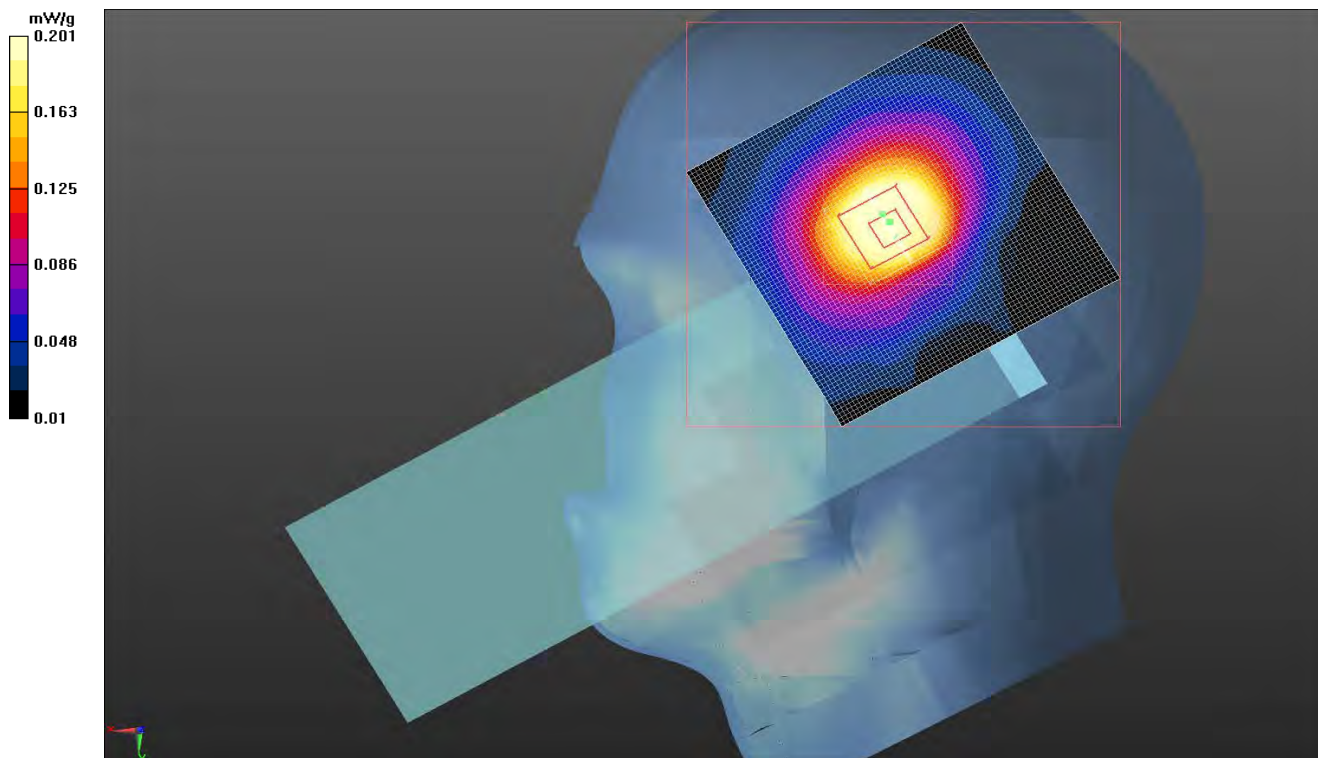

EMC SAR TEST DATA

Room Temperature (°C):	21.6	Humidity (%):	42.9	Test Date:	08/12/11
Liquid Temperature (°C):	21	Barometric Pressure (mb):	1016.7	Tested by:	Jennifer Herrett

Head Test 47 8-12-11

DUT: Handheld Computer (C1); Type: 1001CP01S; Serial: 28311047275

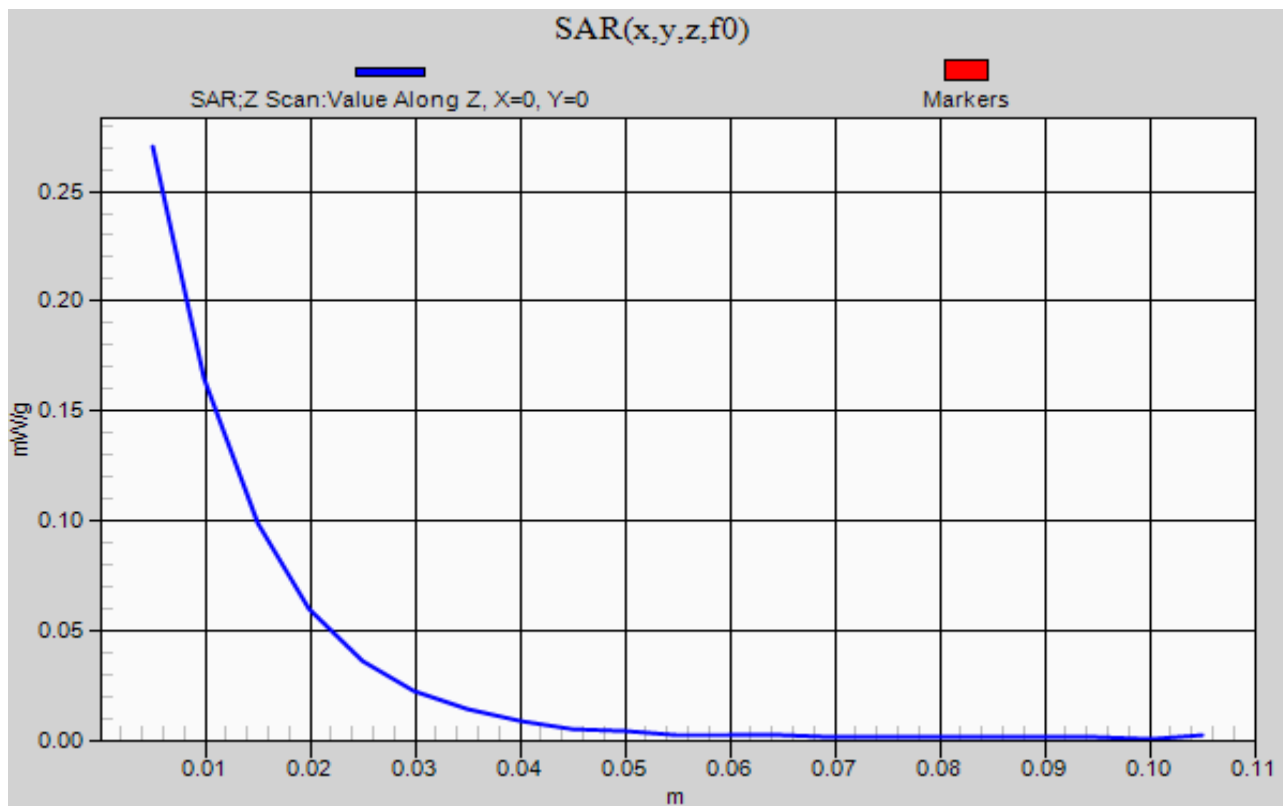

SAR TEST DATA

SAR 2011.02.07

EUT: 1001CP01S	Work Order: ITRM0248
Serial Number: 28311047275	Date: See Data Sheets
Customer: Intermec Technologies Corporation	Temperature: See Data Sheets
Attendees: None	Humidity: See Data Sheets
Project: None	Barometric Pres.: See Data Sheets
Tested by: Jennifer Herrett and Ethan Schoonover	Job Site: EV08

TEST SPECIFICATIONS	Test Method
FCC 2.1093:2011	FCC OET 65C:2001 IEEE Std 1528:2003 FCC KDB 447498 D01 v04 FCC KDB 941225 D01 v02 FCC KDB 648474 D01 V01r05
Health Safety Code 6:2009	RSS-102, Issue 4:2010

COMMENTS
None

DEVIATIONS FROM TEST STANDARD
No Deviations

Configuration #	7 & 8	Signature
------------------------	-------	-----------

Test Configuration	Frequency Band	Body-Worn Accessory	Transmit Frequency	Transmit Channel	Transmit Mode	Data Rate (Mbps)	Audio Accessory	EUT Position	Start Power (Conducted)	SAR Drift During Test (dB)	1g SAR Level	Test #
Body	PCS	Holster	1880	661	GPRS / 1 slot	GMSK (MCS 4)	none	Right	29.57	Note 1	Note 1	41
								Front	29.57	Note 1	Note 1	42
								Left	29.57	0.09	0.050	43
				VR10 Headset			Worst Case	29.57	0.04	0.058	44	
				VR10 Headset			Right	24.54	0.08	0.253	45b	
				none			Front	24.54	-0.18	0.114	46	
			VR10 Headset	Left	24.54	-0.06	0.998	47c				
			VR10 Headset	Left	24.54	0.03	0.932	47c				
			VR10 Headset	Left	24.54	0.06	0.674	47c				
						1852.4	9262	WCDMA / Test Loop 1	12.2 kbps RMC			
			1907.5	9538								

EMC

SAR TEST DATA

Room Temperature (°C):	23.1	Humidity (%):	39.1	Test Date:	08/11/11
Liquid Temperature (°C):	21.8	Barometric Pressure (mb):	1017.9	Tested by:	Ethan Schoonover

Body Test 41 8-15-11

DUT: Handheld Computer (C1); Type: 1001CP01S; Serial: 28311047275

Communication System: GPRS and Edge; Communication System Band: PCS 1900; Frequency: 1880 MHz; Communication System PAR: 9.2 dB
 Medium parameters used: $f = 1880$ MHz; $\sigma = 1.445$ mho/m; $\epsilon_r = 53.39$; $\rho = 1000$ kg/m³

Phantom section: Flat Section

Measurement Standard: DASYS (IEEE/IEC/ANSI C63.19-2007)

DASY5 Configuration:

Probe: ES3DV3 - SN3246; ConvF(4.63, 4.63, 4.63); Calibrated: 11/11/2010

Sensor-Surface: 3mm (Mechanical Surface Detection)

Electronics: DAE4 Sn1237; Calibrated: 11/10/2010

Phantom: ELI 4.0; Type: QDOVA001BA; Serial: 1096

Measurement SW: DASYS2, Version 52.6 (2); SEMCAD X Version 14.4.4 (2829)

Body/Body - Mid/Reference scan (41x91x1): Measurement grid: dx=30mm, dy=30mm

Maximum value of SAR (interpolated) = 2.36e-005 mW/g

Body/Body - Mid/Area scan (71x71x1): Measurement grid: dx=15mm, dy=15mm

Maximum value of SAR (interpolated) = 0.00105 mW/g

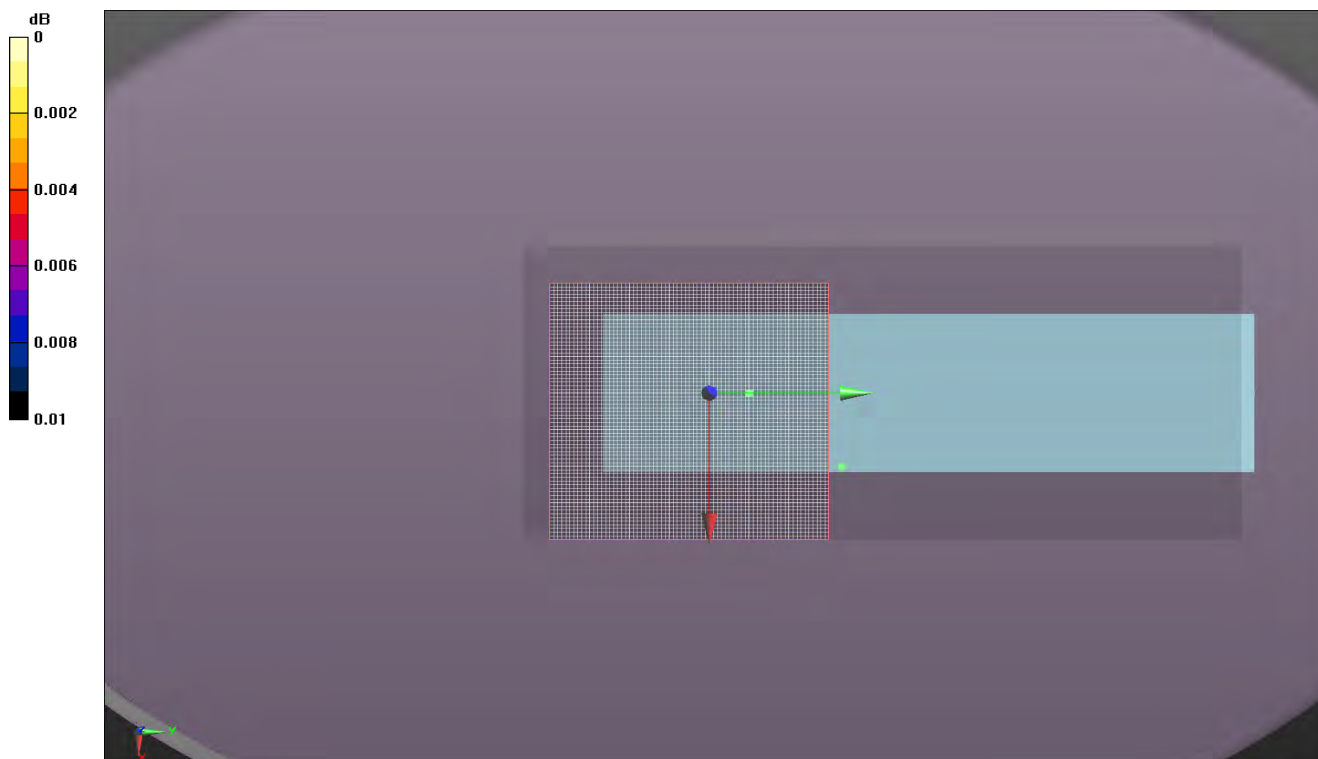

Room Temperature (°C):	23.5	Humidity (%):	44.5	Test Date:	08/11/11
Liquid Temperature (°C):	21.7	Barometric Pressure (mb):	1017.9	Tested by:	Ethan Schoonover

Body Test 42 8-15-11**DUT: Handheld Computer (C1); Type: 1001CP01S; Serial: 28311047275**

Communication System: GPRS and Edge; Communication System Band: PCS 1900; Frequency: 1880 MHz; Communication System PAR: 9.2 dB

Medium parameters used: $f = 1880$ MHz; $\sigma = 1.445$ mho/m; $\epsilon_r = 53.39$; $\rho = 1000$ kg/m³

Phantom section: Flat Section

Measurement Standard: DASYS (IEEE/IEC/ANSI C63.19-2007)

DASY5 Configuration:

Probe: ES3DV3 - SN3246; ConvF(4.63, 4.63, 4.63); Calibrated: 11/11/2010

Sensor-Surface: 3mm (Mechanical Surface Detection)

Electronics: DAE4 Sn1237; Calibrated: 11/10/2010

Phantom: ELI 4.0; Type: QDOVA001BA; Serial: 1096

Measurement SW: DASY52, Version 52.6 (2); SEMCAD X Version 14.4.4 (2829)

Body/Body - Mid/Reference scan (51x101x1): Measurement grid: dx=30mm, dy=30mm

Maximum value of SAR (interpolated) = 0 mW/g

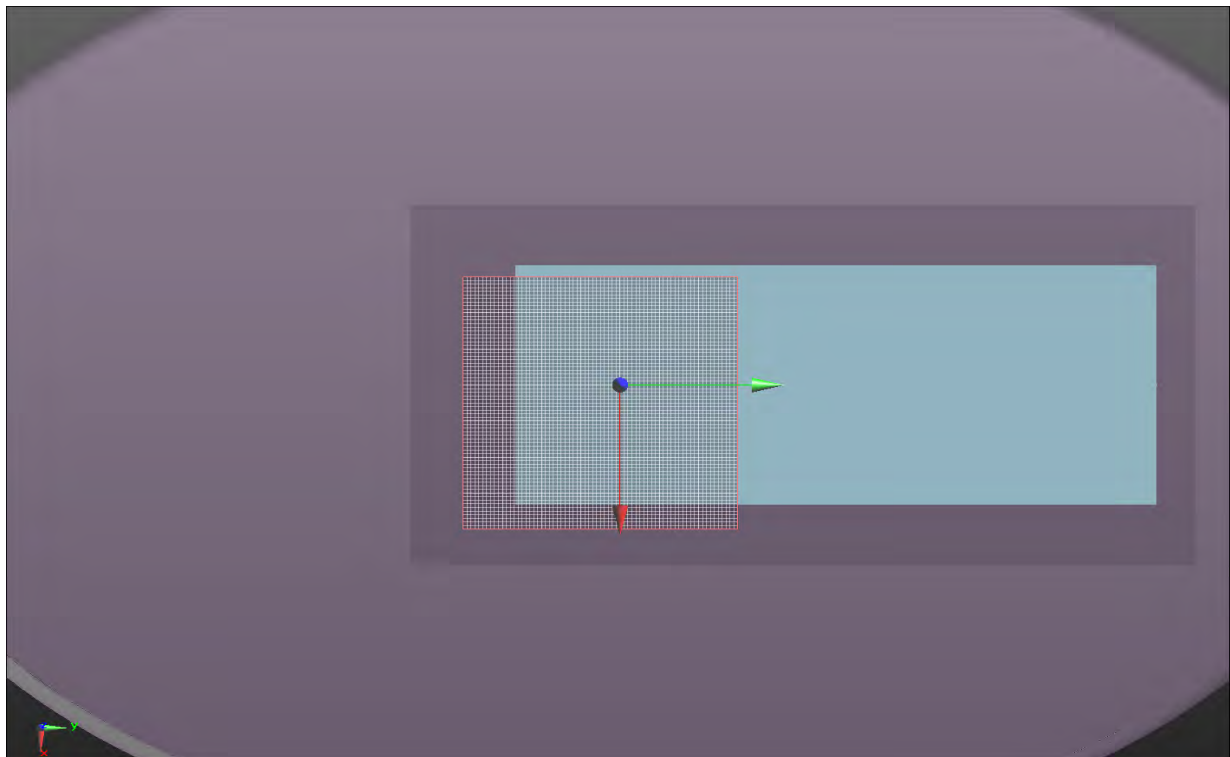
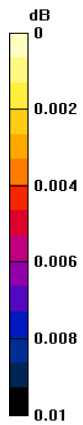
Body/Body - Mid/Area scan (71x71x1): Measurement grid: dx=15mm, dy=15mm

Room Temperature (°C):	23.7	Humidity (%):	48.6	Test Date:	08/11/11
Liquid Temperature (°C):	21.6	Barometric Pressure (mb):	1017.9	Tested by:	Ethan Schoonover

Body Test 43 8-15-11

DUT: Handheld Computer (C1); Type: 1001CP01S; Serial: 28311047275

Communication System: GPRS and Edge; Communication System Band: PCS 1900; Frequency: 1880 MHz; Communication System PAR: 9.2 dB
 Medium parameters used: $f = 1880$ MHz; $\sigma = 1.445$ mho/m; $\epsilon_r = 53.39$; $\rho = 1000$ kg/m³, Medium parameters used: $\sigma = 1.445$ mho/m, $\epsilon_r = 53.39$; $\rho = 1000$ kg/m³
 Phantom section: Flat Section
 Measurement Standard: DASYS (IEEE/IEC/ANSI C63.19-2007)

DASY5 Configuration:

Probe: ES3DV3 - SN3246; ConvF(4.63, 4.63, 4.63); Calibrated: 11/11/2010
 Sensor-Surface: 3mm (Mechanical Surface Detection), Sensor-Surface: 0mm (Fix Surface)
 Electronics: DAE4 Sn1237; Calibrated: 11/10/2010
 Phantom: ELI 4.0; Type: QDOVA001BA; Serial: 1096
 Measurement SW: DASYS2, Version 52.6 (2); SEMCAD X Version 14.4.4 (2829)

Body/Body - Mid/Reference scan (41x91x1): Measurement grid: dx=30mm, dy=30mm
 Maximum value of SAR (interpolated) = 0.051 mW/g

Body/Body - Mid/Area scan (71x71x1): Measurement grid: dx=15mm, dy=15mm
 Maximum value of SAR (interpolated) = 0.119 mW/g

Body/Body - Mid/Zoom Scan (11x13x7)/Cube 0: Measurement grid: dx=5mm, dy=5mm, dz=5mm
 Reference Value = 6.493 V/m; Power Drift = -0.09 dB
 Peak SAR (extrapolated) = 0.086 W/kg
SAR(1 g) = 0.050 mW/g; SAR(10 g) = 0.031 mW/g
 Maximum value of SAR (measured) = 0.060 mW/g

Body/Body - Mid/Z Scan (1x1x21): Measurement grid: dx=20mm, dy=20mm, dz=5mm
 Maximum value of Total (measured) = 4.887 V/m

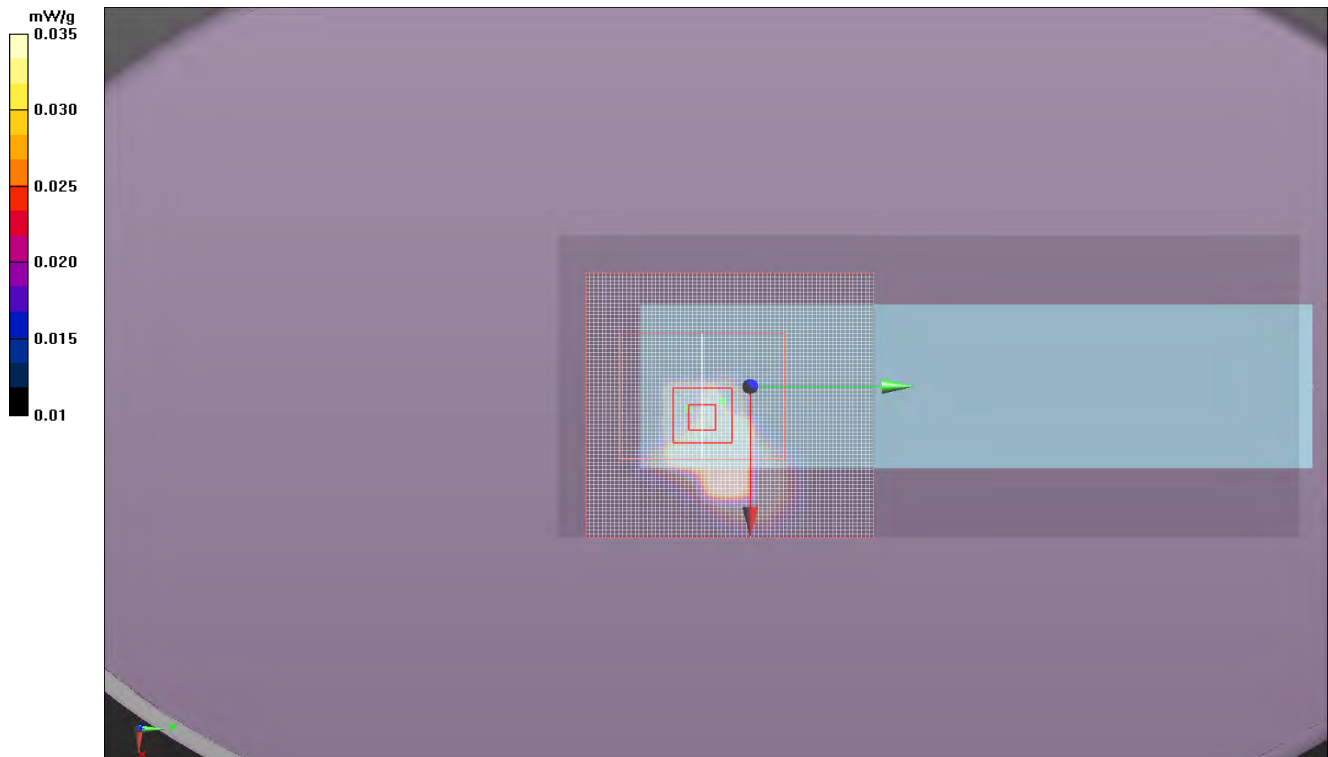

Room Temperature (°C):	22.8	Humidity (%):	42.6	Test Date:	08/11/11
Liquid Temperature (°C):	21.7	Barometric Pressure (mb):	1017.9	Tested by:	Ethan Schoonover

Body Test 44 8-15-11

DUT: Handheld Computer (C1); Type: 1001CP01S; Serial: 28311047275

Communication System: GPRS and Edge; Communication System Band: PCS 1900; Frequency: 1880 MHz; Communication System PAR: 9.2 dB
 Medium parameters used: $f = 1880$ MHz; $\sigma = 1.445$ mho/m; $\epsilon_r = 53.39$; $\rho = 1000$ kg/m³, Medium parameters used: $\sigma = 1.445$ mho/m, $\epsilon_r = 53.39$; $\rho = 1000$ kg/m³
 Phantom section: Flat Section
 Measurement Standard: DASYS (IEEE/IEC/ANSI C63.19-2007)

DASY5 Configuration:

Probe: ES3DV3 - SN3246; ConvF(4.63, 4.63, 4.63); Calibrated: 11/11/2010
 Sensor-Surface: 3mm (Mechanical Surface Detection), Sensor-Surface: 0mm (Fix Surface)
 Electronics: DAE4 Sn1237; Calibrated: 11/10/2010
 Phantom: ELI 4.0; Type: QDOVA001BA; Serial: 1096
 Measurement SW: DASYS2, Version 52.6 (2); SEMCAD X Version 14.4.4 (2829)

Body/Body - Mid/Reference scan (51x111x1): Measurement grid: dx=30mm, dy=30mm
 Maximum value of SAR (interpolated) = 0.082 mW/g

Body/Body - Mid/Area scan (71x71x1): Measurement grid: dx=15mm, dy=15mm
 Maximum value of SAR (interpolated) = 0.136 mW/g

Body/Body - Mid/Zoom Scan (11x13x7)/Cube 0: Measurement grid: dx=5mm, dy=5mm, dz=5mm
 Reference Value = 6.929 V/m; Power Drift = 0.04 dB
 Peak SAR (extrapolated) = 0.101 W/kg
SAR(1 g) = 0.058 mW/g; SAR(10 g) = 0.034 mW/g
 Maximum value of SAR (measured) = 0.070 mW/g

Body/Body - Mid/Z Scan (1x1x21): Measurement grid: dx=20mm, dy=20mm, dz=5mm
 Maximum value of Total (measured) = 4.769 V/m

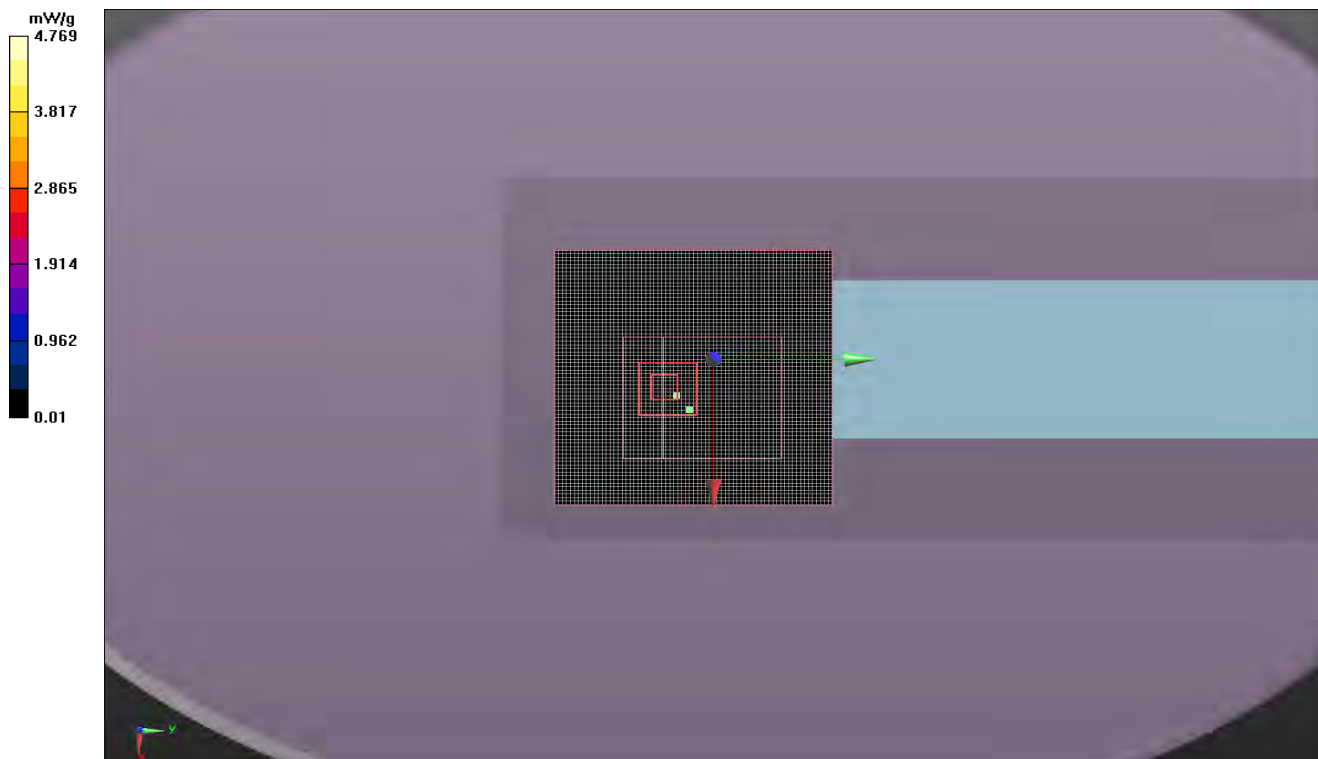

EMC

SAR TEST DATA

Room Temperature (°C):	24.5	Humidity (%):	43.5	Test Date:	08/18/11
Liquid Temperature (°C):	22.8	Barometric Pressure (mb):	1022.5	Tested by:	Jennifer Herrett

Body Test 45b 8-18-11

DUT: Handheld Computer (C1); Type: 1001CP01S; Serial: 28311047275

Communication System: CW; Frequency: 1880 MHz

Medium parameters used (interpolated): $f = 1880$ MHz; $\sigma = 1.485$ mho/m; $\epsilon = 52.984$; $\rho = 1000$ kg/m³, Medium parameters used: $\sigma = 1.47915$ mho/m, $\epsilon = 53.0056$; $\rho = 1000$ kg/m³

Phantom section: Flat Section

Measurement Standard: DASYS5 (IEEE/IEC/ANSI C63.19-2007)

DASYS5 Configuration:

Probe: ES3DV3 - SN3173; ConvF(4.55, 4.55, 4.55); Calibrated: 2/23/2011

Sensor-Surface: 3mm (Mechanical Surface Detection), Sensor-Surface: 0mm (Fix Surface)

Electronics: DAE4 Sn1237; Calibrated: 11/10/2010

Phantom: ELI 4.0; Type: QDOVA001BA; Serial: 1096

Measurement SW: DASYS2, Version 52.6 (2); SEMCAD X Version 14.4.4 (2829)

Body/Body - Mid/Reference scan (51x111x1): Measurement grid: dx=30mm, dy=30mm

Info: Interpolated medium parameters used for SAR evaluation.

Maximum value of SAR (interpolated) = 0.291 mW/g

Body/Body - Mid/Area scan (71x71x1): Measurement grid: dx=15mm, dy=15mm

Info: Interpolated medium parameters used for SAR evaluation.

Maximum value of SAR (interpolated) = 0.272 mW/g

Body/Body - Mid/Zoom Scan (7x7x7)/Cube 0: Measurement grid: dx=5mm, dy=5mm, dz=5mm

Reference Value = 14.021 V/m; Power Drift = 0.08 dB

Peak SAR (extrapolated) = 0.305 W/kg

SAR(1 g) = 0.253 mW/g; SAR(10 g) = 0.204 mW/g

Info: Interpolated medium parameters used for SAR evaluation.

Maximum value of SAR (measured) = 0.274 mW/g

Body/Body - Mid/Z Scan (1x1x21): Measurement grid: dx=20mm, dy=20mm, dz=5mm

Maximum value of Total (measured) = 12.359 V/m



EMC

SAR TEST DATA

Room Temperature (°C):	23.3	Humidity (%):	46.2	Test Date:	08/15/11
Liquid Temperature (°C):	21.4	Barometric Pressure (mb):	1017.4	Tested by:	Ethan Schoonover

Body Test 46 8-15-11

DUT: Handheld Computer (C1); Type: 1001CP01S; Serial: 28311047275

Communication System: CW; Frequency: 1880 MHz

Medium parameters used: $f = 1880$ MHz; $\sigma = 1.445$ mho/m; $\epsilon = 53.39$; $\rho = 1000$ kg/m³, Medium parameters used: $\sigma = 1.445$ mho/m, $\epsilon = 53.39$; $\rho = 1000$ kg/m³

Phantom section: Flat Section

Measurement Standard: DASYS (IEEE/IEC/ANSI C63.19-2007)

DASYS Configuration:

Probe: ES3DV3 - SN3246; ConvF(4.63, 4.63, 4.63); Calibrated: 11/11/2010

Sensor-Surface: 3mm (Mechanical Surface Detection), Sensor-Surface: 0mm (Fix Surface)

Electronics: DAE4 Sn1237; Calibrated: 11/10/2010

Phantom: ELI 4.0; Type: QDOVA001BA; Serial: 1096

Measurement SW: DASYS2, Version 52.6 (2); SEMCAD X Version 14.4.4 (2829)

Body/Body - Mid/Reference scan (51x101x1): Measurement grid: dx=30mm, dy=30mm

Maximum value of SAR (interpolated) = 0.139 mW/g

Body/Body - Mid/Area scan (71x71x1): Measurement grid: dx=15mm, dy=15mm

Maximum value of SAR (interpolated) = 0.141 mW/g

Body/Body - Mid/Zoom Scan (11x13x7)/Cube 0: Measurement grid: dx=5mm, dy=5mm, dz=5mm

Reference Value = 9.976 V/m; Power Drift = -0.18 dB

Peak SAR (extrapolated) = 0.185 W/kg

SAR(1 g) = 0.114 mW/g; SAR(10 g) = 0.071 mW/g

Maximum value of SAR (measured) = 0.134 mW/g

Body/Body - Mid/Z Scan (1x1x21): Measurement grid: dx=20mm, dy=20mm, dz=5mm

Maximum value of Total (measured) = 7.691 V/m

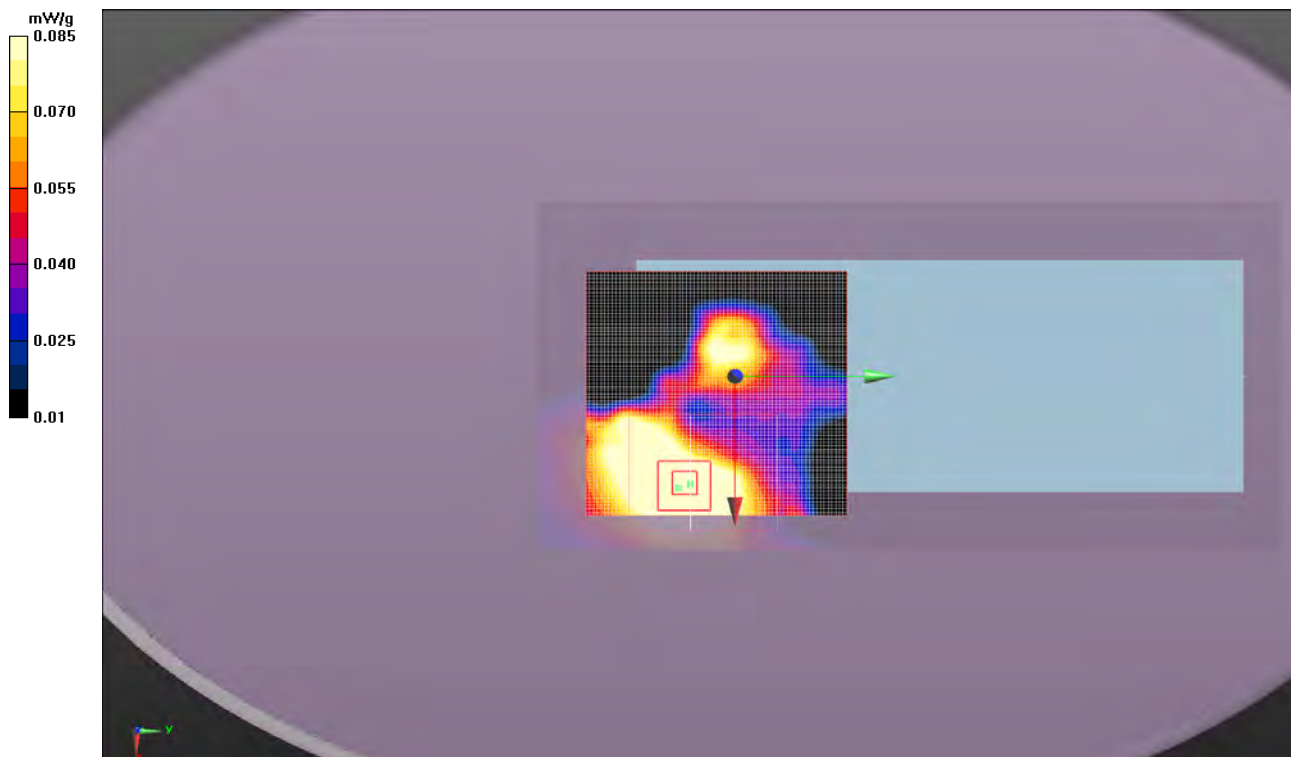

EMC

SAR TEST DATA

Room Temperature (°C):	25.2	Humidity (%):	45.8	Test Date:	08/19/11
Liquid Temperature (°C):	22.5	Barometric Pressure (mb):	1017.9	Tested by:	Jennifer Herrett

Body Test 47c 8-19-11

DUT: Handheld Computer (C1); Type: 1001CP01S; Serial: 28311047275

Communication System: CW; Frequency: 1880 MHz

Medium parameters used (interpolated): $f = 1880$ MHz; $\sigma = 1.482$ mho/m; $\epsilon = 52.673$; $\rho = 1000$ kg/m³, Medium parameters used: $\sigma = 1.4765$ mho/m, $\epsilon = 52.689$; $\rho = 1000$ kg/m³

Phantom section: Flat Section

Measurement Standard: DASYS5 (IEEE/IEC/ANSI C63.19-2007)

DASYS5 Configuration:

Probe: ES3DV3 - SN3173; ConvF(4.55, 4.55, 4.55); Calibrated: 2/23/2011

Sensor-Surface: 3mm (Mechanical Surface Detection), Sensor-Surface: 0mm (Fix Surface)

Electronics: DAE4 Sn1237; Calibrated: 11/10/2010

Phantom: ELI 4.0; Type: QDOVA001BA; Serial: 1096

Measurement SW: DASYS2, Version 52.6 (2); SEMCAD X Version 14.4.4 (2829)

Body/Body - Mid/Reference scan (51x111x1): Measurement grid: dx=30mm, dy=30mm

Info: Interpolated medium parameters used for SAR evaluation.

Maximum value of SAR (interpolated) = 0.945 mW/g

Body/Body - Mid/Area scan (71x71x1): Measurement grid: dx=15mm, dy=15mm

Info: Interpolated medium parameters used for SAR evaluation.

Maximum value of SAR (interpolated) = 1.149 mW/g

Body/Body - Mid/Zoom Scan (7x7x7)/Cube 0: Measurement grid: dx=5mm, dy=5mm, dz=5mm

Reference Value = 29.138 V/m; Power Drift = -0.06 dB

Peak SAR (extrapolated) = 1.537 W/kg

SAR(1 g) = 0.998 mW/g; SAR(10 g) = 0.605 mW/g

Info: Interpolated medium parameters used for SAR evaluation.

Maximum value of SAR (measured) = 1.188 mW/g

Body/Body - Mid/Z Scan (1x1x21): Measurement grid: dx=20mm, dy=20mm, dz=5mm

Maximum value of Total (measured) = 22.718 V/m

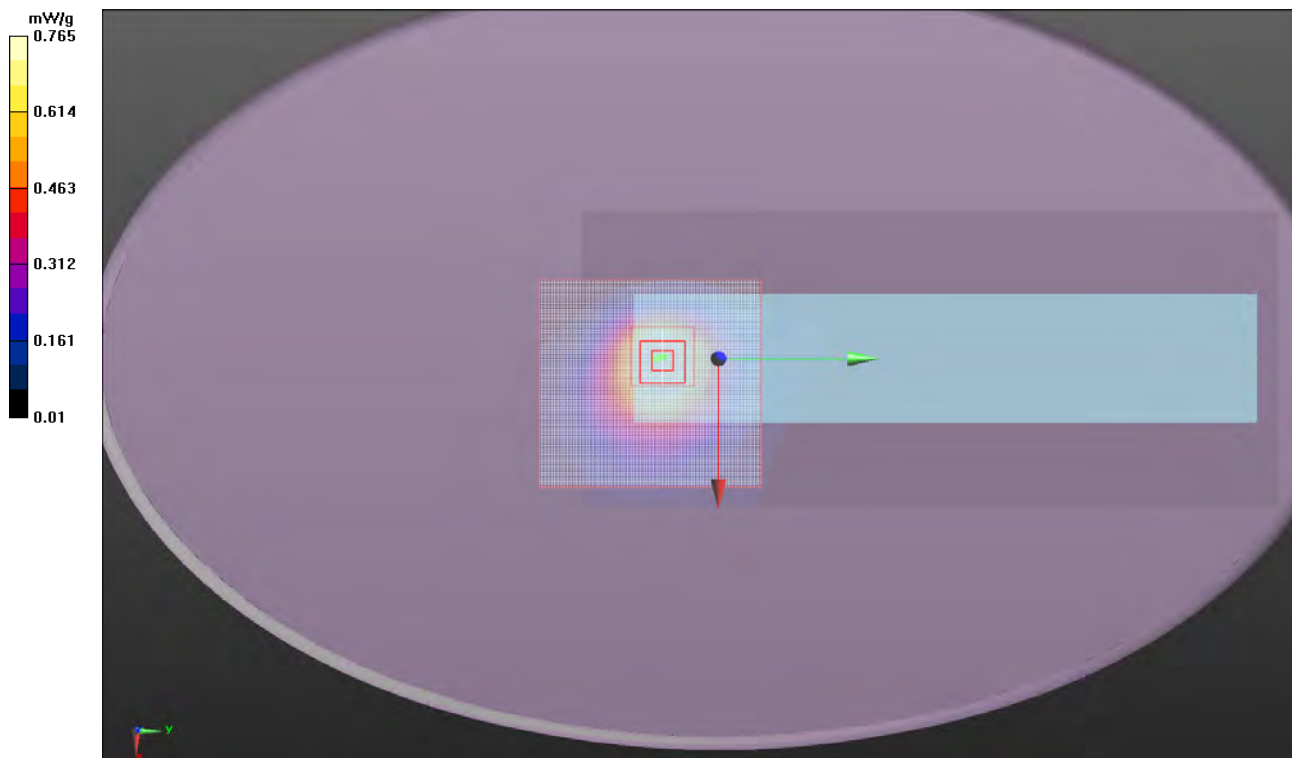

EMC

SAR TEST DATA

Room Temperature (°C):	21.2	Humidity (%):	39	Test Date:	08/20/11
Liquid Temperature (°C):	20.8	Barometric Pressure (mb):	1009.7	Tested by:	Jennifer Herrett

Body Test 47d2 8-20-11

DUT: Handheld Computer (C1); Type: 1001CP01S; Serial: 28311047275

Communication System: CW; Frequency: 1852.4 MHz

Medium parameters used (interpolated): $f = 1852.4$ MHz; $\sigma = 1.452$ mho/m; $\epsilon = 52.777$; $\rho = 1000$ kg/m³, Medium parameters used: $\sigma = 1.44903$ mho/m, $\epsilon = 52.7855$; $\rho = 1000$ kg/m³

Phantom section: Flat Section

Measurement Standard: DASYS5 (IEEE/IEC/ANSI C63.19-2007)

DASYS5 Configuration:

Probe: ES3DV3 - SN3173; ConvF(4.55, 4.55, 4.55); Calibrated: 2/23/2011

Sensor-Surface: 3mm (Mechanical Surface Detection), Sensor-Surface: 0mm (Fix Surface)

Electronics: DAE4 Sn1237; Calibrated: 11/10/2010

Phantom: ELI 4.0; Type: QDOVA001BA; Serial: 1096

Measurement SW: DASYS2, Version 52.6 (2); SEMCAD X Version 14.4.4 (2829)

Body/Body - Low/Reference scan (51x111x1): Measurement grid: dx=30mm, dy=30mm

Info: Interpolated medium parameters used for SAR evaluation.

Maximum value of SAR (interpolated) = 0.926 mW/g

Body/Body - Low/Area scan (71x71x1): Measurement grid: dx=15mm, dy=15mm

Info: Interpolated medium parameters used for SAR evaluation.

Maximum value of SAR (interpolated) = 1.100 mW/g

Body/Body - Low/Zoom Scan (7x7x7)/Cube 0: Measurement grid: dx=5mm, dy=5mm, dz=5mm

Reference Value = 26.721 V/m; Power Drift = 0.03 dB

Peak SAR (extrapolated) = 1.411 W/kg

SAR(1 g) = 0.932 mW/g; SAR(10 g) = 0.580 mW/g

Info: Interpolated medium parameters used for SAR evaluation.

Maximum value of SAR (measured) = 1.092 mW/g

Body/Body - Low/Z Scan (1x1x21): Measurement grid: dx=20mm, dy=20mm, dz=5mm

Maximum value of Total (measured) = 22.147 V/m

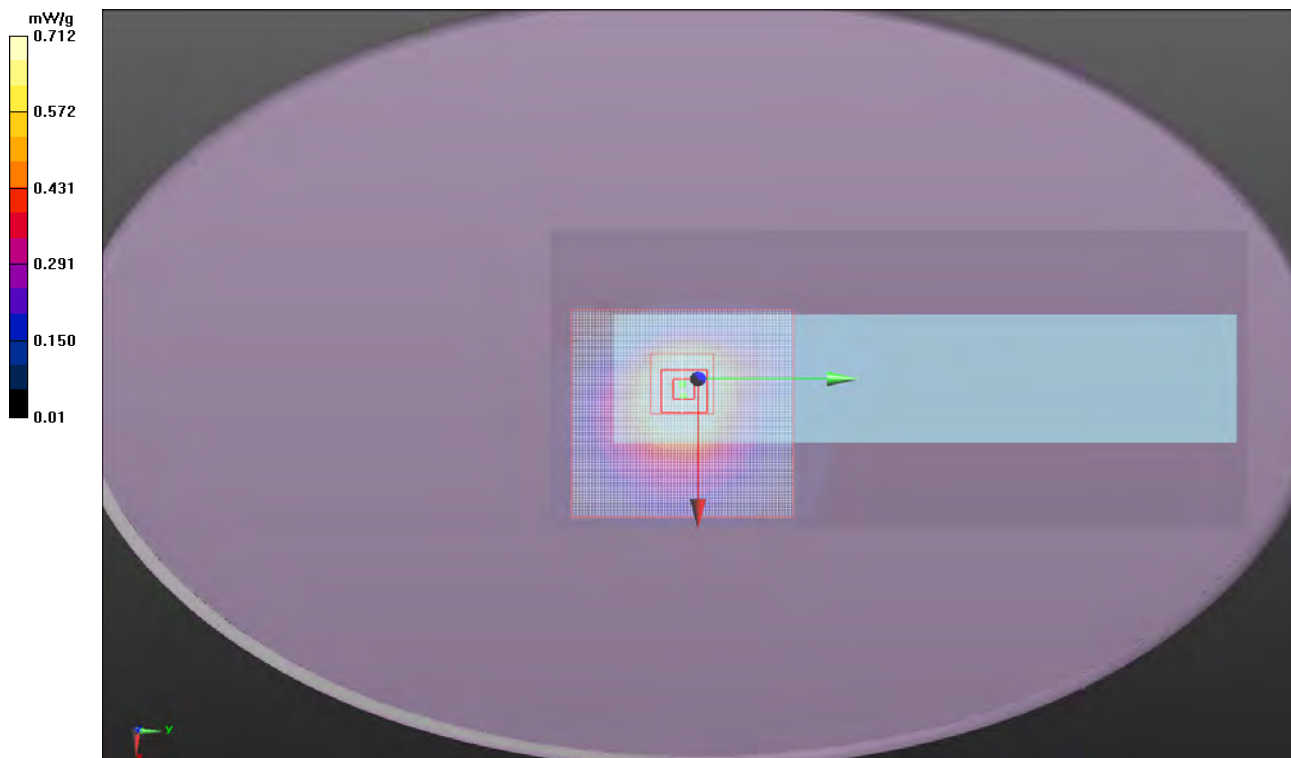

EMC

SAR TEST DATA

Room Temperature (°C):	21.2	Humidity (%):	39	Test Date:	08/20/11
Liquid Temperature (°C):	20.8	Barometric Pressure (mb):	1009.7	Tested by:	Jennifer Herrett

Body Test 47e 8-20-11

DUT: Handheld Computer (C1); Type: 1001CP01S; Serial: 28311047275

Communication System: CW; Frequency: 1907.5 MHz

Medium parameters used (interpolated): $f = 1907.5$ MHz; $\sigma = 1.512$ mho/m; $\epsilon = 52.586$; $\rho = 1000$ kg/m³, Medium parameters used: $\sigma = 1.51739$ mho/m, $\epsilon = 52.5713$; $\rho = 1000$ kg/m³

Phantom section: Flat Section

Measurement Standard: DASYS5 (IEEE/IEC/ANSI C63.19-2007)

DASYS5 Configuration:

Probe: ES3DV3 - SN3173; ConvF(4.55, 4.55, 4.55); Calibrated: 2/23/2011

Sensor-Surface: 3mm (Mechanical Surface Detection), Sensor-Surface: 0mm (Fix Surface)

Electronics: DAE4 Sn1237; Calibrated: 11/10/2010

Phantom: ELI 4.0; Type: QDOVA001BA; Serial: 1096

Measurement SW: DASYS2, Version 52.6 (2); SEMCAD X Version 14.4.4 (2829)

Body/Body - High/Reference scan (51x111x1): Measurement grid: dx=30mm, dy=30mm

Info: Interpolated medium parameters used for SAR evaluation.

Maximum value of SAR (interpolated) = 0.733 mW/g

Body/Body - High/Area scan (71x71x1): Measurement grid: dx=15mm, dy=15mm

Info: Interpolated medium parameters used for SAR evaluation.

Maximum value of SAR (interpolated) = 0.789 mW/g

Body/Body - High/Zoom Scan (7x7x7)/Cube 0: Measurement grid: dx=5mm, dy=5mm, dz=5mm

Reference Value = 22.556 V/m; Power Drift = 0.06 dB

Peak SAR (extrapolated) = 1.045 W/kg

SAR(1 g) = 0.674 mW/g; SAR(10 g) = 0.413 mW/g

Info: Interpolated medium parameters used for SAR evaluation.

Maximum value of SAR (measured) = 0.800 mW/g

Body/Body - High/Z Scan (1x1x21): Measurement grid: dx=20mm, dy=20mm, dz=5mm

Maximum value of Total (measured) = 18.420 V/m

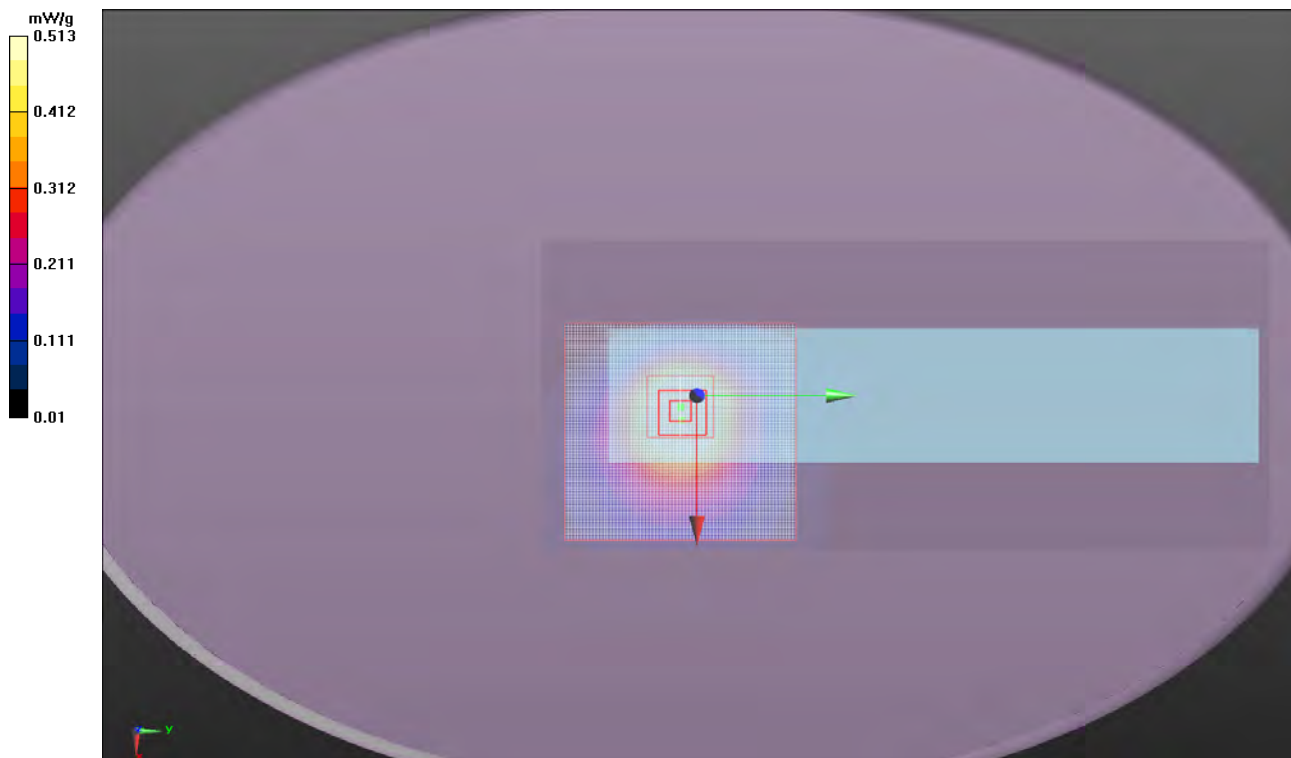

EMC SAR TEST DATA

Room Temperature (°C):	25.2	Humidity (%):	45.8	Test Date:	08/19/11
Liquid Temperature (°C):	22.5	Barometric Pressure (mb):	1017.9	Tested by:	Jennifer Herrett

Body Test 47c 8-19-11

DUT: Handheld Computer (C1); Type: 1001CP01S; Serial: 28311047275

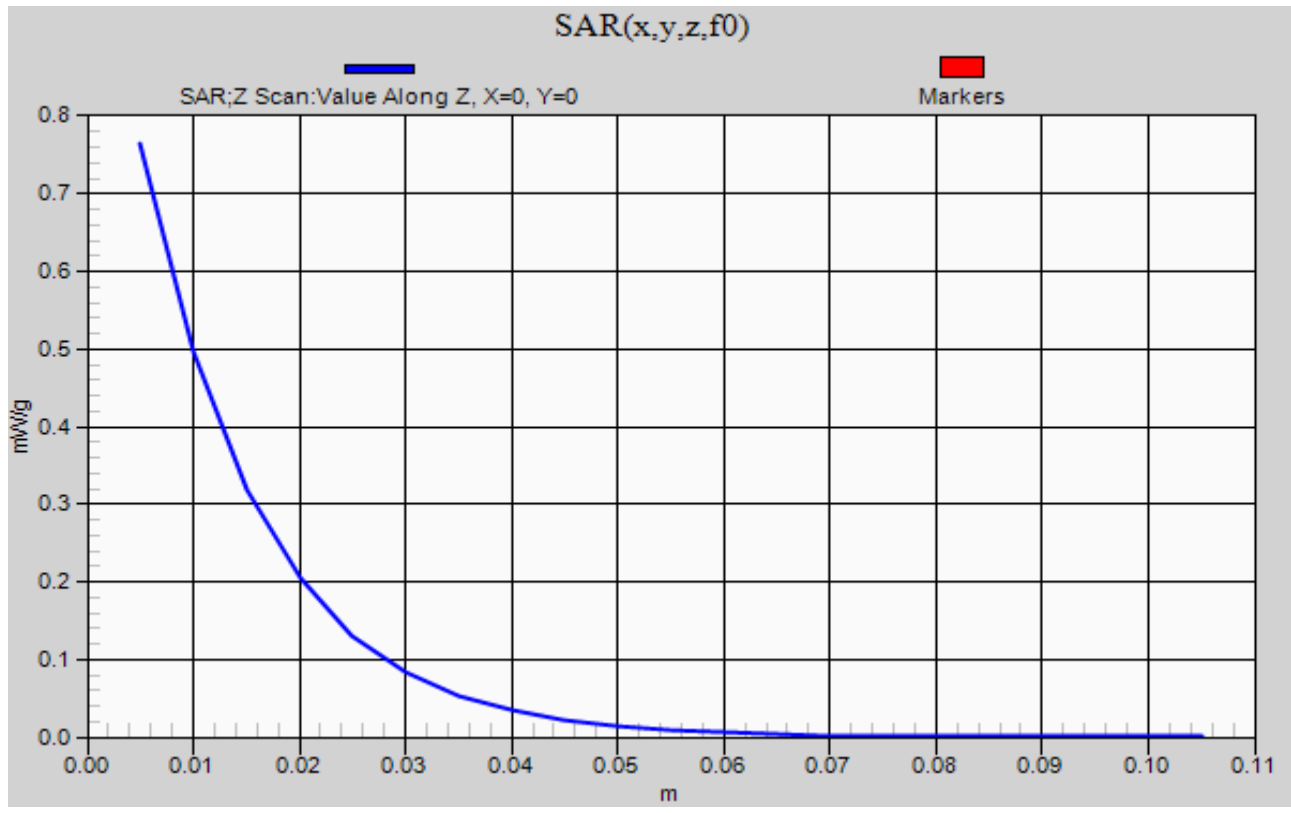

SAR TEST DATA

EUT: 1001CP01S	Work Order: ITRM0248
Serial Number: 28311047275	Date: See Data Sheets
Customer: Intermec Technologies Corporation	Temperature: See Data Sheets
Attendees: None	Humidity: See Data Sheets
Project: None	Barometric Pres.: See Data Sheets
Tested by: Jennifer Herrett and Ethan Schoonover	Job Site: EV08
TEST SPECIFICATIONS	
FCC 2.1093:2011	Test Method FCC OET 65C:2001 IEEE Std 1528:2003 FCC KDB 447498 D01 v04 FCC KDB 941225 D01 v02 FCC KDB 648474 D01 V01r05
Health Safety Code 6:2009	RSS-102, Issue 4:2010
COMMENTS	
None	
DEVIATIONS FROM TEST STANDARD	
No Deviations	
Configuration #	9
	Signature <i>Jennifer Herrett</i>

Test Configuration	Frequency Band	Body-Worn Accessory	Transmit Frequency	Transmit Channel	Transmit Mode	Data Rate (Mbps)	Audio Accessory	EUT Position	Start Power (Conducted)	SAR Drift During Test (dB)	1g SAR Level	Test #
Head	AWS 1700MHz	None	1735.4	1427	WCDMA / Test Loop 1	12.2 kbps RMC	Left	Cheek	23.9	0.31	0.277	57
								Tilt	23.9	0.03	0.184	58
	AWS 1700MHz	None	1735.4	1427	WCDMA / Test Loop 1	12.2 kbps RMC	Right	Cheek	23.9	0.09	0.596	59
								Tilt	23.9	-0.04	0.368	60

EMC

Room Temperature (°C):	23.7	Humidity (%):	48	Test Date:	08/22/11
Liquid Temperature (°C):	22.1	Barometric Pressure (mb):	1016.5	Tested by:	Jennifer Herrett

Head Test 57 8-22-11

DUT: Handheld Computer (C1); Type: 1001CP01S; Serial: 28311047275

Communication System: CW; Frequency: 1735.4 MHz

Medium parameters used (interpolated): $f = 1735.4$ MHz; $\sigma = 1.369$ mho/m; $\epsilon = 40.847$; $\rho = 1000$ kg/m³, Medium parameters used: $\sigma = 1.35851$ mho/m, $\epsilon = 40.9024$; $\rho = 1000$ kg/m³

Phantom section: Left Section

Measurement Standard: DASYS (IEEE/IEC/ANSI C63.19-2007)

DASYS Configuration:

Probe: ES3DV3 - SN3173; ConvF(5.2, 5.2, 5.2); Calibrated: 2/23/2011

Sensor-Surface: 3mm (Mechanical Surface Detection), Sensor-Surface: 0mm (Fix Surface)

Electronics: DAE4 Sn1237; Calibrated: 11/10/2010

Phantom: SAM with CRP; Type: SAM; Serial: 1598

Measurement SW: DASYS2, Version 52.6 (2); SEMCAD X Version 14.4.4 (2829)

Head - Left/Cheek - Mid/Zoom Scan (7x7x7)/Cube 0: Measurement grid: dx=5mm, dy=5mm, dz=5mm

Reference Value = 15.890 V/m; Power Drift = 0.18 dB

Peak SAR (extrapolated) = 0.477 W/kg

SAR(1 g) = 0.277 mW/g; SAR(10 g) = 0.156 mW/g

[Info: Interpolated medium parameters used for SAR evaluation.](#)

Maximum value of SAR (measured) = 0.338 mW/g

Head - Left/Cheek - Mid/Area scan (91x71x1): Measurement grid: dx=15mm, dy=15mm

[Info: Interpolated medium parameters used for SAR evaluation.](#)

Maximum value of SAR (interpolated) = 0.330 mW/g

Head - Left/Cheek - Mid/Z Scan (1x1x21): Measurement grid: dx=20mm, dy=20mm, dz=5mm

Maximum value of Total (measured) = 12.494 V/m

Head - Left/Cheek - Mid/Reference scan (51x91x1): Measurement grid: dx=30mm, dy=30mm

[Info: Interpolated medium parameters used for SAR evaluation.](#)

Maximum value of SAR (interpolated) = 0.257 mW/g

Head - Left/Cheek - Mid/Zoom Scan 2 (8x11x7)/Cube 0: Measurement grid: dx=5mm, dy=5mm, dz=5mm

Reference Value = 15.890 V/m; Power Drift = 0.31 dB

Peak SAR (extrapolated) = 0.484 W/kg

SAR(1 g) = 0.285 mW/g; SAR(10 g) = 0.159 mW/g

[Info: Interpolated medium parameters used for SAR evaluation.](#)

Maximum value of SAR (measured) = 0.344 mW/g

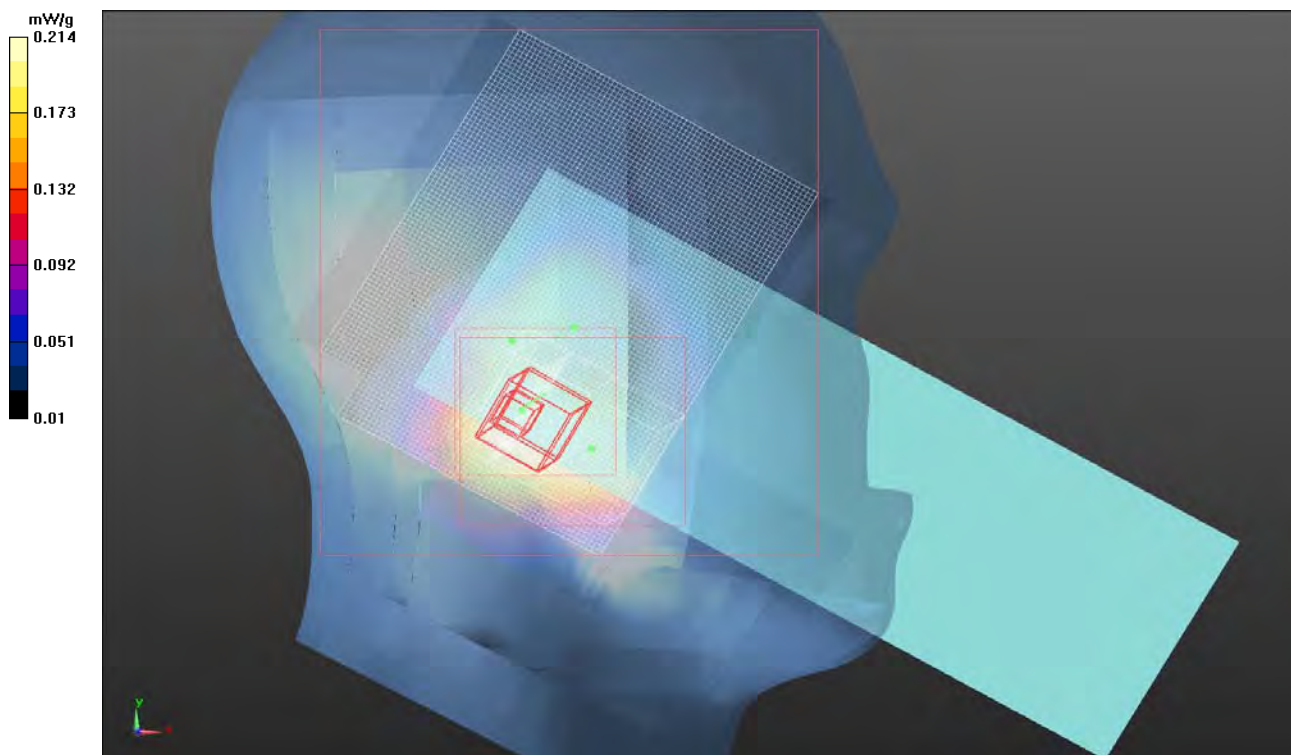

EMC

SAR TEST DATA

Room Temperature (°C):	23.7	Humidity (%):	48	Test Date:	08/22/11
Liquid Temperature (°C):	22.1	Barometric Pressure (mb):	1016.5	Tested by:	Jennifer Herrett

Head Test 58 8-22-11

DUT: Handheld Computer (C1); Type: 1001CP01S; Serial: 28311047275

Communication System: CW; Frequency: 1735.4 MHz

Medium parameters used (interpolated): $f = 1735.4$ MHz; $\sigma = 1.369$ mho/m; $\epsilon = 40.847$; $\rho = 1000$ kg/m³, Medium parameters used: $\sigma = 1.35851$ mho/m, $\epsilon = 40.9024$; $\rho = 1000$ kg/m³

Phantom section: Left Section

Measurement Standard: DASYS (IEEE/IEC/ANSI C63.19-2007)

DASYS Configuration:

Probe: ES3DV3 - SN3173; ConvF(5.2, 5.2, 5.2); Calibrated: 2/23/2011

Sensor-Surface: 3mm (Mechanical Surface Detection), Sensor-Surface: 0mm (Fix Surface)

Electronics: DAE4 Sn1237; Calibrated: 11/10/2010

Phantom: SAM with CRP; Type: SAM; Serial: 1598

Measurement SW: DASYS2, Version 52.6 (2); SEMCAD X Version 14.4.4 (2829)

Head - Left/Tilt - Mid/Zoom Scan (7x7x7)/Cube 0: Measurement grid: dx=5mm, dy=5mm, dz=5mm

Reference Value = 13.459 V/m; Power Drift = 0.03 dB

Peak SAR (extrapolated) = 0.346 W/kg

SAR(1 g) = 0.184 mW/g; SAR(10 g) = 0.100 mW/g

[Info: Interpolated medium parameters used for SAR evaluation.](#)

Maximum value of SAR (measured) = 0.231 mW/g

Head - Left/Tilt - Mid/Area scan (91x71x1): Measurement grid: dx=15mm, dy=15mm

[Info: Interpolated medium parameters used for SAR evaluation.](#)

Maximum value of SAR (interpolated) = 0.249 mW/g

Head - Left/Tilt - Mid/Z Scan (1x1x21): Measurement grid: dx=20mm, dy=20mm, dz=5mm

Maximum value of Total (measured) = 9.882 V/m

Head - Left/Tilt - Mid/Reference scan (51x91x1): Measurement grid: dx=30mm, dy=30mm

[Info: Interpolated medium parameters used for SAR evaluation.](#)

Maximum value of SAR (interpolated) = 0.176 mW/g

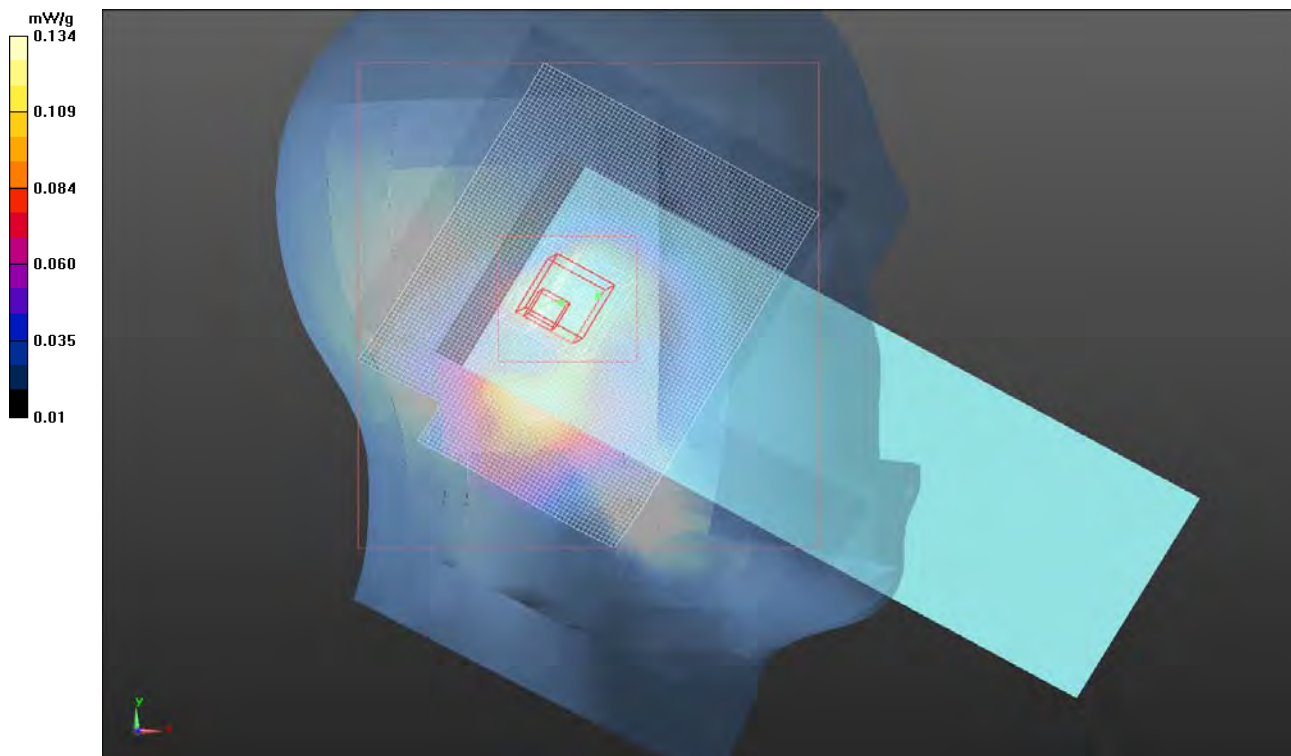

EMC

Room Temperature (°C):	21.9	Humidity (%):	42.2	Test Date:	08/20/11
Liquid Temperature (°C):	21.1	Barometric Pressure (mb):	1009.7	Tested by:	Jennifer Herrett

Head Test 59 8-20-11

DUT: Handheld Computer (C1); Type: 1001CP01S; Serial: 28311047275

Communication System: CW; Frequency: 1735.4 MHz

Medium parameters used (interpolated): $f = 1735.4$ MHz; $\sigma = 1.369$ mho/m; $\epsilon = 40.847$; $\rho = 1000$ kg/m³, Medium parameters used: $\sigma = 1.35851$ mho/m, $\epsilon = 40.9024$; $\rho = 1000$ kg/m³

Phantom section: Right Section

Measurement Standard: DASYS5 (IEEE/IEC/ANSI C63.19-2007)

DASYS5 Configuration:

Probe: ES3DV3 - SN3173; ConvF(5.2, 5.2, 5.2); Calibrated: 2/23/2011

Sensor-Surface: 3mm (Mechanical Surface Detection), Sensor-Surface: 0mm (Fix Surface)

Electronics: DAE4 Sn1237; Calibrated: 11/10/2010

Phantom: SAM with CRP; Type: SAM; Serial: 1598

Measurement SW: DASYS2, Version 52.6 (2); SEMCAD X Version 14.4.4 (2829)

Head - Right/Cheek - Mid/Reference scan (51x91x1): Measurement grid: dx=30mm, dy=30mm

Info: Interpolated medium parameters used for SAR evaluation.

Maximum value of SAR (interpolated) = 0.424 mW/g

Head - Right/Cheek - Mid/Z Scan (1x1x21): Measurement grid: dx=20mm, dy=20mm, dz=5mm

Maximum value of Total (measured) = 17.829 V/m

Head - Right/Cheek - Mid/Zoom Scan (7x7x7)/Cube 0: Measurement grid: dx=5mm, dy=5mm, dz=5mm

Reference Value = 21.801 V/m; Power Drift = 0.09 dB

Peak SAR (extrapolated) = 1.121 W/kg

SAR(1 g) = 0.596 mW/g; SAR(10 g) = 0.307 mW/g

Info: Interpolated medium parameters used for SAR evaluation.

Maximum value of SAR (measured) = 0.740 mW/g

Head - Right/Cheek - Mid/Area scan (71x71x1): Measurement grid: dx=15mm, dy=15mm

Info: Interpolated medium parameters used for SAR evaluation.

Maximum value of SAR (interpolated) = 0.644 mW/g

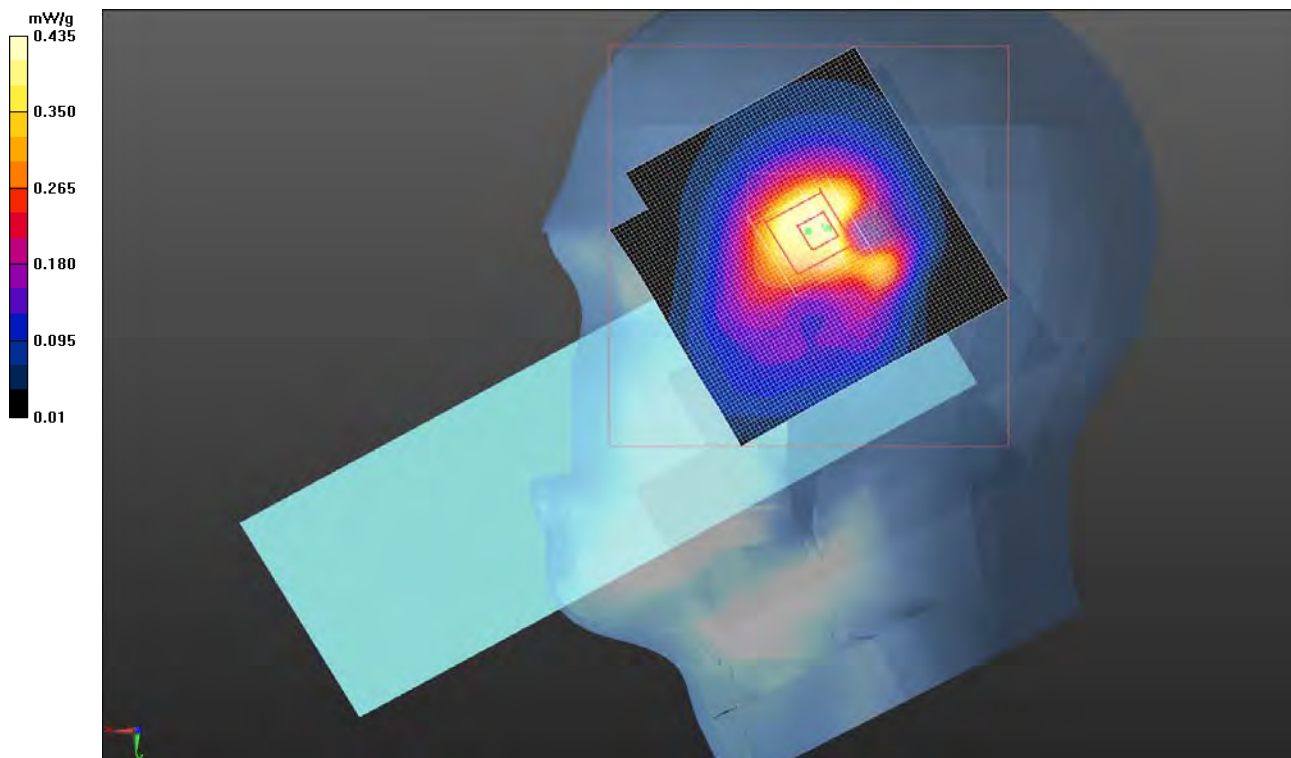

EMC

SAR TEST DATA

Room Temperature (°C):	21.9	Humidity (%):	42.2	Test Date:	08/20/11
Liquid Temperature (°C):	21.1	Barometric Pressure (mb):	1009.7	Tested by:	Jennifer Herrett

Head Test 60 8-20-11

DUT: Handheld Computer (C1); Type: 1001CP01S; Serial: 28311047275

Communication System: CW; Frequency: 1735.4 MHz

Medium parameters used (interpolated): $f = 1735.4$ MHz; $\sigma = 1.369$ mho/m; $\epsilon = 40.847$; $\rho = 1000$ kg/m³, Medium parameters used: $\sigma = 1.35851$ mho/m, $\epsilon = 40.9024$; $\rho = 1000$ kg/m³

Phantom section: Right Section

Measurement Standard: DASYS5 (IEEE/IEC/ANSI C63.19-2007)

DASYS5 Configuration:

Probe: ES3DV3 - SN3173; ConvF(5.2, 5.2, 5.2); Calibrated: 2/23/2011

Sensor-Surface: 3mm (Mechanical Surface Detection), Sensor-Surface: 0mm (Fix Surface)

Electronics: DAE4 Sn1237; Calibrated: 11/10/2010

Phantom: SAM with CRP; Type: SAM; Serial: 1598

Measurement SW: DASYS2, Version 52.6 (2); SEMCAD X Version 14.4.4 (2829)

Head - Right/Tilt - Mid/Zoom Scan (7x7x7)/Cube 0: Measurement grid: dx=5mm, dy=5mm, dz=5mm

Reference Value = 18.572 V/m; Power Drift = -0.04 dB

Peak SAR (extrapolated) = 0.677 W/kg

SAR(1 g) = 0.368 mW/g; SAR(10 g) = 0.190 mW/g

[Info: Interpolated medium parameters used for SAR evaluation.](#)

Maximum value of SAR (measured) = 0.456 mW/g

Head - Right/Tilt - Mid/Z Scan (1x1x21): Measurement grid: dx=20mm, dy=20mm, dz=5mm

Maximum value of Total (measured) = 14.185 V/m

Head - Right/Tilt - Mid/Reference scan (51x91x1): Measurement grid: dx=30mm, dy=30mm

[Info: Interpolated medium parameters used for SAR evaluation.](#)

Maximum value of SAR (interpolated) = 0.383 mW/g

Head - Right/Tilt - Mid/Area scan (71x71x1): Measurement grid: dx=15mm, dy=15mm

[Info: Interpolated medium parameters used for SAR evaluation.](#)

Maximum value of SAR (interpolated) = 0.434 mW/g

Head - Right/Tilt - Mid/Zoom Scan 2 (7x7x7)/Cube 0: Measurement grid: dx=5mm, dy=5mm, dz=5mm

Reference Value = 18.572 V/m; Power Drift = -0.04 dB

Peak SAR (extrapolated) = 0.720 W/kg

SAR(1 g) = 0.314 mW/g; SAR(10 g) = 0.143 mW/g

[Info: Interpolated medium parameters used for SAR evaluation.](#)

Maximum value of SAR (measured) = 0.440 mW/g

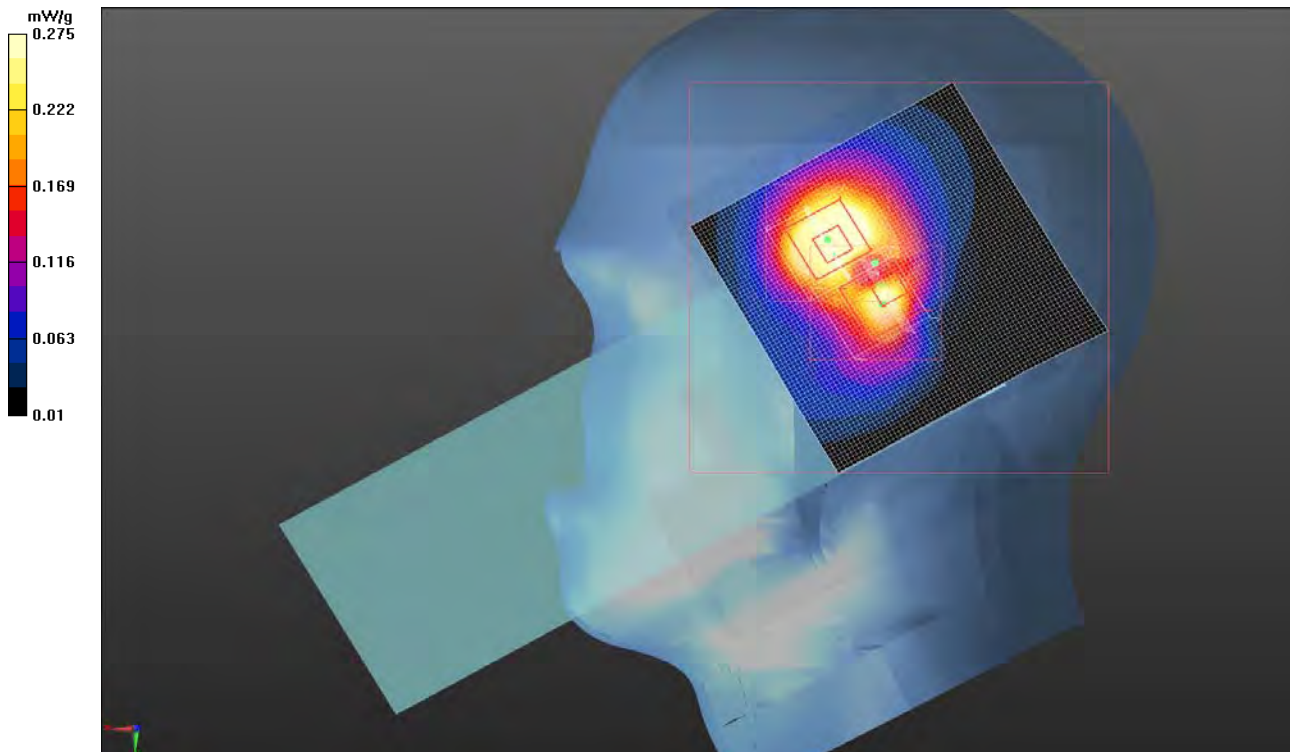

EMC SAR TEST DATA

Room Temperature (°C):	21.9	Humidity (%):	42.2	Test Date:	08/20/11
Liquid Temperature (°C):	21.1	Barometric Pressure (mb):	1009.7	Tested by:	Jennifer Herrett

Head Test 59 8-20-11

DUT: Handheld Computer (C1); Type: 1001CP01S; Serial: 28311047275

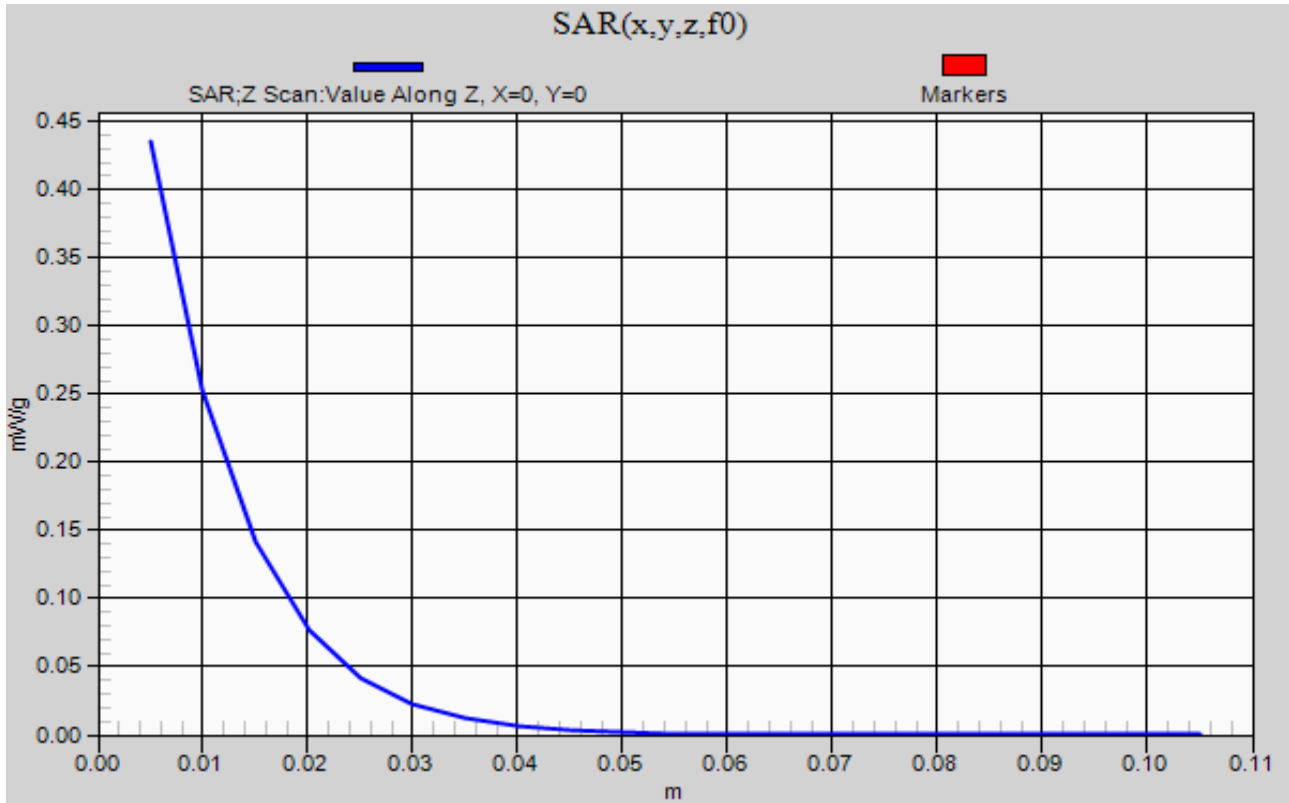

SAR TEST DATA

EMC

EUT:	1001CP01S	Work Order:	ITRM0248
Serial Number:	28311047275	Date:	See Data Sheets
Customer:	Intermec Technologies Corporation	Temperature:	See Data Sheets
Attendees:	None	Humidity:	See Data Sheets
Project:	None	Barometric Pres.:	See Data Sheets
Tested by:	Jennifer Herrett and Ethan Schoonover	Job Site:	EV08
TEST SPECIFICATIONS		Test Method	
FCC 2.1093:2011		FCC OET 65C:2001 IEEE Std 1528:2003 FCC KDB 447498 D01 v04 FCC KDB 941225 D01 v02 FCC KDB 648474 D01 V01r05	
Health Safety Code 6:2009		RSS-102, Issue 4:2010	
COMMENTS			
None			
DEVIATIONS FROM TEST STANDARD			
No Deviations			
Configuration #	8	Signature <i>Jennifer Herrett</i>	

Test Configuration	Frequency Band	Body-Worn Accessory	Transmit Frequency	Transmit Channel	Transmit Mode	Data Rate (Mbps)	Audio Accessory	EUT Position	Start Power (Conducted)	SAR Drift During Test (dB)	1g SAR Level	Test #
Body	AWS 1700MHz	Holster	1735.4	1427	WCDMA /12.2 kbps RMC / Test Loop 1		VR10 Headset	Front	23.99	0.04	0.236	53
			1712.4	1312				Left	23.99	0.03	0.854	54
			1752.6	1513				Left	23.99	0.08	0.559	54c
								Left	23.99	-0.02	0.76	54d

EMC

SAR TEST DATA

Room Temperature (°C):	24.1	Humidity (%):	43.5	Test Date:	08/22/11
Liquid Temperature (°C):	21.4	Barometric Pressure (mb):	1015.8	Tested by:	Ethan Schoonover

Body Test 53 8-22-11

DUT: Handheld Computer (C1); Type: 1001CP01S; Serial: 28311047275

Communication System: CW; Frequency: 1735.4 MHz

Medium parameters used (interpolated): $f = 1735.4$ MHz; $\sigma = 1.462$ mho/m; $\epsilon = 53.221$; $\rho = 1000$ kg/m³, Medium parameters used: $\sigma = 1.48$ mho/m, $\epsilon = 53.13$; $\rho = 1000$ kg/m³

Phantom section: Flat Section

Measurement Standard: DASYS5 (IEEE/IEC/ANSI C63.19-2007)

DASYS5 Configuration:

Probe: ES3DV3 - SN3173; ConvF(4.87, 4.87, 4.87); Calibrated: 2/23/2011

Sensor-Surface: 3mm (Mechanical Surface Detection), Sensor-Surface: 0mm (Fix Surface)

Electronics: DAE4 Sn1237; Calibrated: 11/10/2010

Phantom: ELI 4.0; Type: QDOVA001BA; Serial: 1096

Measurement SW: DASYS2, Version 52.6 (2); SEMCAD X Version 14.4.4 (2829)

Body/Body - Mid/Reference scan (51x111x1): Measurement grid: dx=30mm, dy=30mm

Info: Interpolated medium parameters used for SAR evaluation.

Maximum value of SAR (interpolated) = 0.264 mW/g

Body/Body - Mid/Area scan (71x71x1): Measurement grid: dx=15mm, dy=15mm

Info: Interpolated medium parameters used for SAR evaluation.

Maximum value of SAR (interpolated) = 0.256 mW/g

Body/Body - Mid/Zoom Scan (7x7x7)/Cube 0: Measurement grid: dx=5mm, dy=5mm, dz=5mm

Reference Value = 13.571 V/m; Power Drift = 0.04 dB

Peak SAR (extrapolated) = 0.370 W/kg

SAR(1 g) = 0.236 mW/g; SAR(10 g) = 0.138 mW/g

Info: Interpolated medium parameters used for SAR evaluation.

Maximum value of SAR (measured) = 0.284 mW/g

Body/Body - Mid/Z Scan (1x1x21): Measurement grid: dx=20mm, dy=20mm, dz=5mm

Maximum value of Total (measured) = 11.140 V/m

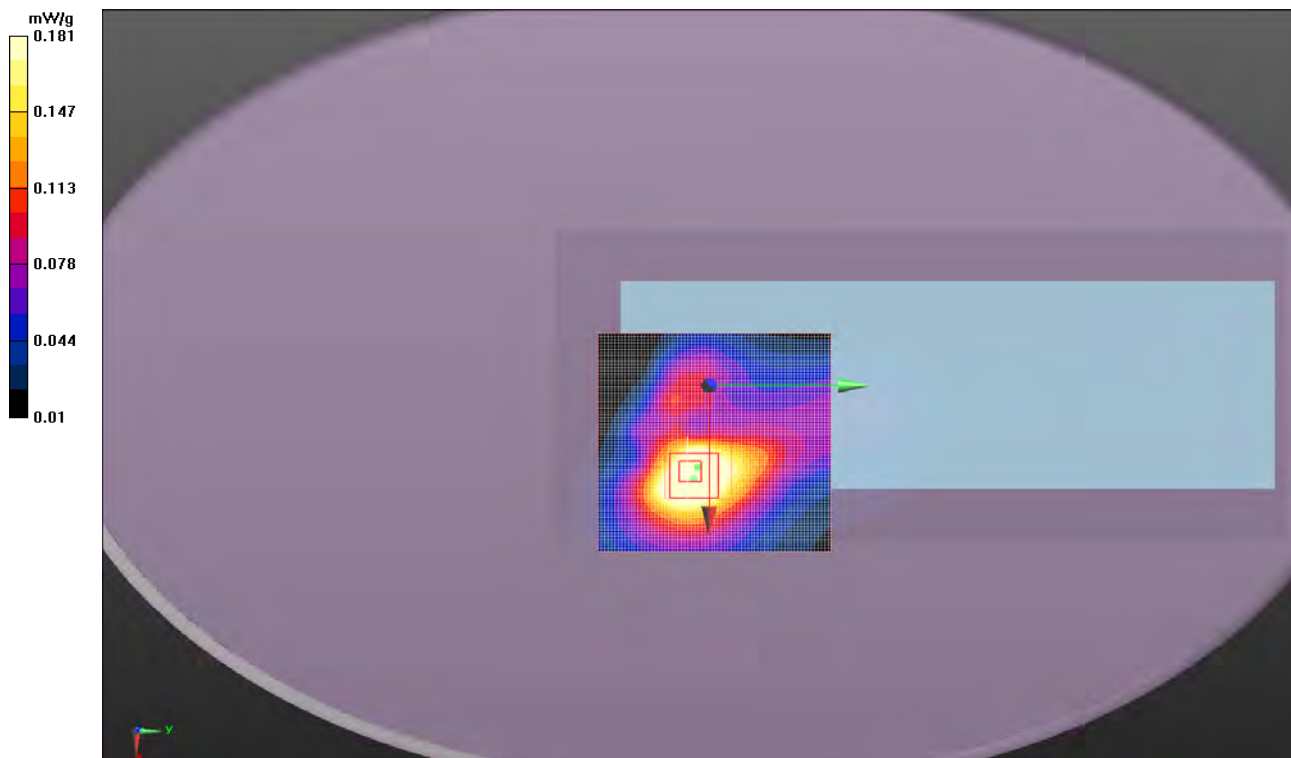

Room Temperature (°C):	24.1	Humidity (%):	43.5	Test Date:	08/22/11
Liquid Temperature (°C):	21.4	Barometric Pressure (mb):	1015.8	Tested by:	Ethan Schoonover

Body Test 54 8-22-11

DUT: Handheld Computer (C1); Type: 1001CP01S; Serial: 28311047275

Communication System: CW; Frequency: 1735.4 MHz

Medium parameters used (interpolated): $f = 1735.4$ MHz; $\sigma = 1.462$ mho/m; $\epsilon = 53.221$; $\rho = 1000$ kg/m³, Medium parameters used: $\sigma = 1.48$ mho/m, $\epsilon = 53.13$; $\rho = 1000$ kg/m³

Phantom section: Flat Section

Measurement Standard: DASYS5 (IEEE/IEC/ANSI C63.19-2007)

DASYS5 Configuration:

Probe: ES3DV3 - SN3173; ConvF(4.87, 4.87, 4.87); Calibrated: 2/23/2011

Sensor-Surface: 3mm (Mechanical Surface Detection), Sensor-Surface: 0mm (Fix Surface)

Electronics: DAE4 Sn1237; Calibrated: 11/10/2010

Phantom: ELI 4.0; Type: QDOVA001BA; Serial: 1096

Measurement SW: DASYS2, Version 52.6 (2); SEMCAD X Version 14.4.4 (2829)

Body/Body - Mid/Reference scan (51x111x1): Measurement grid: dx=30mm, dy=30mm

Info: Interpolated medium parameters used for SAR evaluation.

Maximum value of SAR (interpolated) = 0.895 mW/g

Body/Body - Mid/Area scan (71x71x1): Measurement grid: dx=15mm, dy=15mm

Info: Interpolated medium parameters used for SAR evaluation.

Maximum value of SAR (interpolated) = 1.004 mW/g

Body/Body - Mid/Zoom Scan (7x7x7)/Cube 0: Measurement grid: dx=5mm, dy=5mm, dz=5mm

Reference Value = 26.846 V/m; Power Drift = 0.03 dB

Peak SAR (extrapolated) = 1.276 W/kg

SAR(1 g) = 0.854 mW/g; SAR(10 g) = 0.532 mW/g

Info: Interpolated medium parameters used for SAR evaluation.

Maximum value of SAR (measured) = 1.001 mW/g

Body/Body - Mid/Z Scan (1x1x21): Measurement grid: dx=20mm, dy=20mm, dz=5mm

Maximum value of Total (measured) = 21.433 V/m

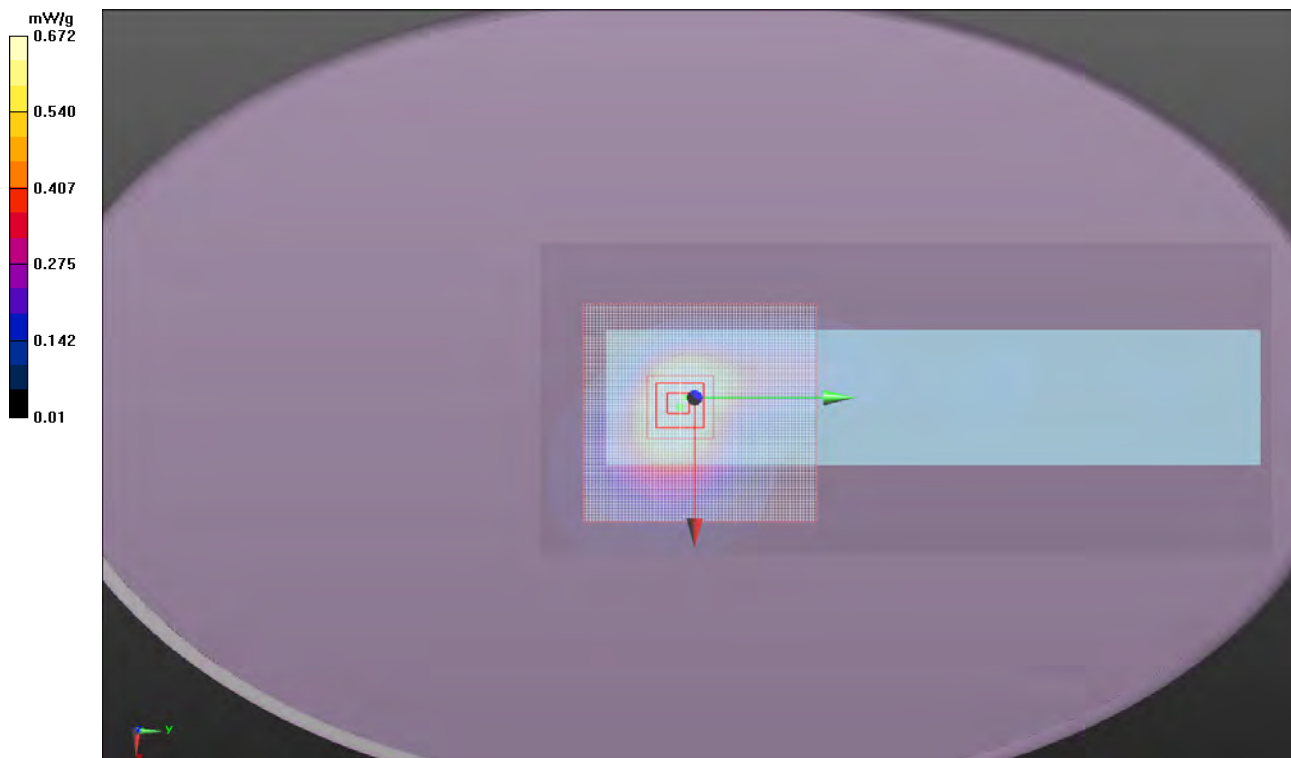

EMC

SAR TEST DATA

Room Temperature (°C):	23.6	Humidity (%):	44.8	Test Date:	08/22/11
Liquid Temperature (°C):	23.1	Barometric Pressure (mb):	1015.8	Tested by:	Ethan Schoonover

Body Test 54c 8-22-11

DUT: Handheld Computer (C1); Type: 1001CP01S; Serial: 28311047275

Communication System: CW; Frequency: 1712.4 MHz

Medium parameters used (interpolated): $f = 1712.4$ MHz; $\sigma = 1.435$ mho/m; $\epsilon = 53.363$; $\rho = 1000$ kg/m³, Medium parameters used: $\sigma = 1.42$ mho/m, $\epsilon = 53.44$; $\rho = 1000$ kg/m³

Phantom section: Flat Section

Measurement Standard: DASYS5 (IEEE/IEC/ANSI C63.19-2007)

DASYS5 Configuration:

Probe: ES3DV3 - SN3173; ConvF(4.87, 4.87, 4.87); Calibrated: 2/23/2011

Sensor-Surface: 3mm (Mechanical Surface Detection), Sensor-Surface: 0mm (Fix Surface)

Electronics: DAE4 Sn1237; Calibrated: 11/10/2010

Phantom: ELI 4.0; Type: QDOVA001BA; Serial: 1096

Measurement SW: DASYS2, Version 52.6 (2); SEMCAD X Version 14.4.4 (2829)

Body/Body - Mid/Reference scan (51x111x1): Measurement grid: dx=30mm, dy=30mm

Info: Interpolated medium parameters used for SAR evaluation.

Maximum value of SAR (interpolated) = 0.647 mW/g

Body/Body - Mid/Area scan (71x71x1): Measurement grid: dx=15mm, dy=15mm

Info: Interpolated medium parameters used for SAR evaluation.

Maximum value of SAR (interpolated) = 0.648 mW/g

Body/Body - Mid/Zoom Scan (7x7x7)/Cube 0: Measurement grid: dx=5mm, dy=5mm, dz=5mm

Reference Value = 22.073 V/m; Power Drift = 0.08 dB

Peak SAR (extrapolated) = 0.821 W/kg

SAR(1 g) = 0.559 mW/g; SAR(10 g) = 0.354 mW/g

Info: Interpolated medium parameters used for SAR evaluation.

Maximum value of SAR (measured) = 0.656 mW/g

Body/Body - Mid/Z Scan (1x1x21): Measurement grid: dx=20mm, dy=20mm, dz=5mm

Maximum value of Total (measured) = 17.606 V/m

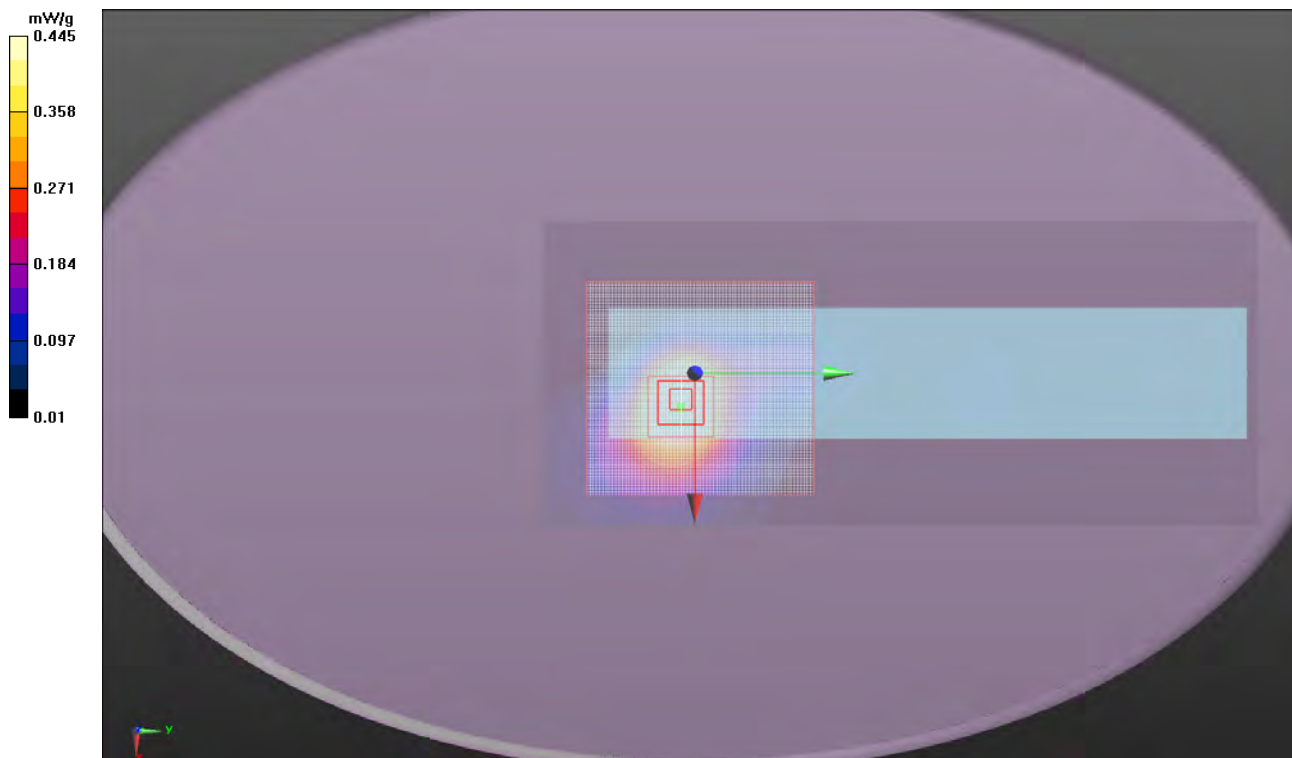

EMC

SAR TEST DATA

Room Temperature (°C):	23.6	Humidity (%):	44.8	Test Date:	08/22/11
Liquid Temperature (°C):	23.1	Barometric Pressure (mb):	1015.8	Tested by:	Ethan Schoonover

Body Test 54d 8-22-11

DUT: Handheld Computer (C1); Type: 1001CP01S; Serial: 28311047275

Communication System: CW; Frequency: 1752.6 MHz

Medium parameters used (interpolated): $f = 1752.6$ MHz; $\sigma = 1.483$ mho/m; $\epsilon = 53.118$; $\rho = 1000$ kg/m³, Medium parameters used: $\sigma = 1.48$ mho/m, $\epsilon = 53.13$; $\rho = 1000$ kg/m³

Phantom section: Flat Section

Measurement Standard: DASYS5 (IEEE/IEC/ANSI C63.19-2007)

DASYS5 Configuration:

Probe: ES3DV3 - SN3173; ConvF(4.87, 4.87, 4.87); Calibrated: 2/23/2011

Sensor-Surface: 3mm (Mechanical Surface Detection), Sensor-Surface: 0mm (Fix Surface)

Electronics: DAE4 Sn1237; Calibrated: 11/10/2010

Phantom: ELI 4.0; Type: QDOVA001BA; Serial: 1096

Measurement SW: DASYS2, Version 52.6 (2); SEMCAD X Version 14.4.4 (2829)

Body/Body - Mid/Reference scan (51x111x1): Measurement grid: dx=30mm, dy=30mm

Info: Interpolated medium parameters used for SAR evaluation.

Maximum value of SAR (interpolated) = 0.844 mW/g

Body/Body - Mid/Area scan (71x71x1): Measurement grid: dx=15mm, dy=15mm

Info: Interpolated medium parameters used for SAR evaluation.

Maximum value of SAR (interpolated) = 0.909 mW/g

Body/Body - Mid/Zoom Scan (7x7x7)/Cube 0: Measurement grid: dx=5mm, dy=5mm, dz=5mm

Reference Value = 24.633 V/m; Power Drift = -0.02 dB

Peak SAR (extrapolated) = 1.131 W/kg

SAR(1 g) = 0.760 mW/g; SAR(10 g) = 0.479 mW/g

Info: Interpolated medium parameters used for SAR evaluation.

Maximum value of SAR (measured) = 0.887 mW/g

Body/Body - Mid/Z Scan (1x1x21): Measurement grid: dx=20mm, dy=20mm, dz=5mm

Maximum value of Total (measured) = 19.942 V/m

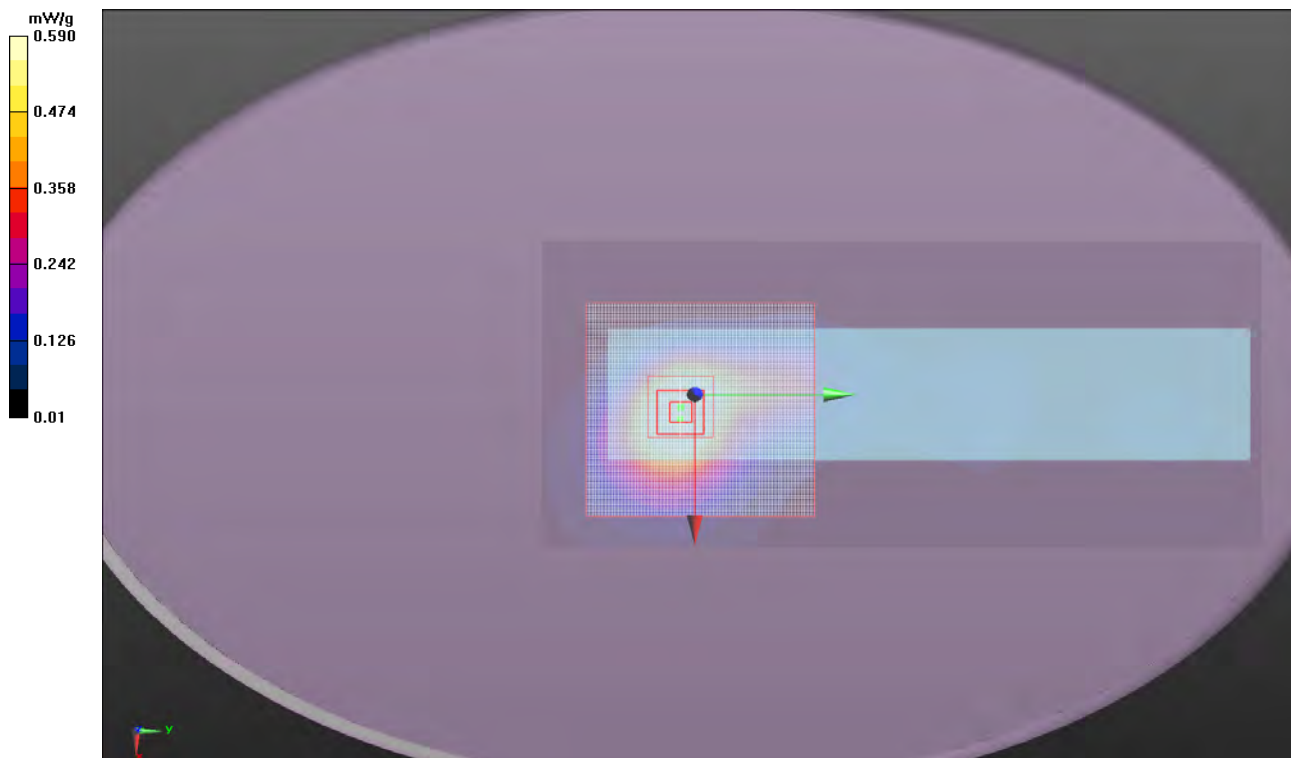

EMC SAR TEST DATA

Room Temperature (°C):	24.1	Humidity (%):	43.5	Test Date:	08/22/11
Liquid Temperature (°C):	21.4	Barometric Pressure (mb):	1015.8	Tested by:	Ethan Schoonover

Body Test 54 8-22-11

DUT: Hand Held Computer; Type: CN70; Serial: 24411047084

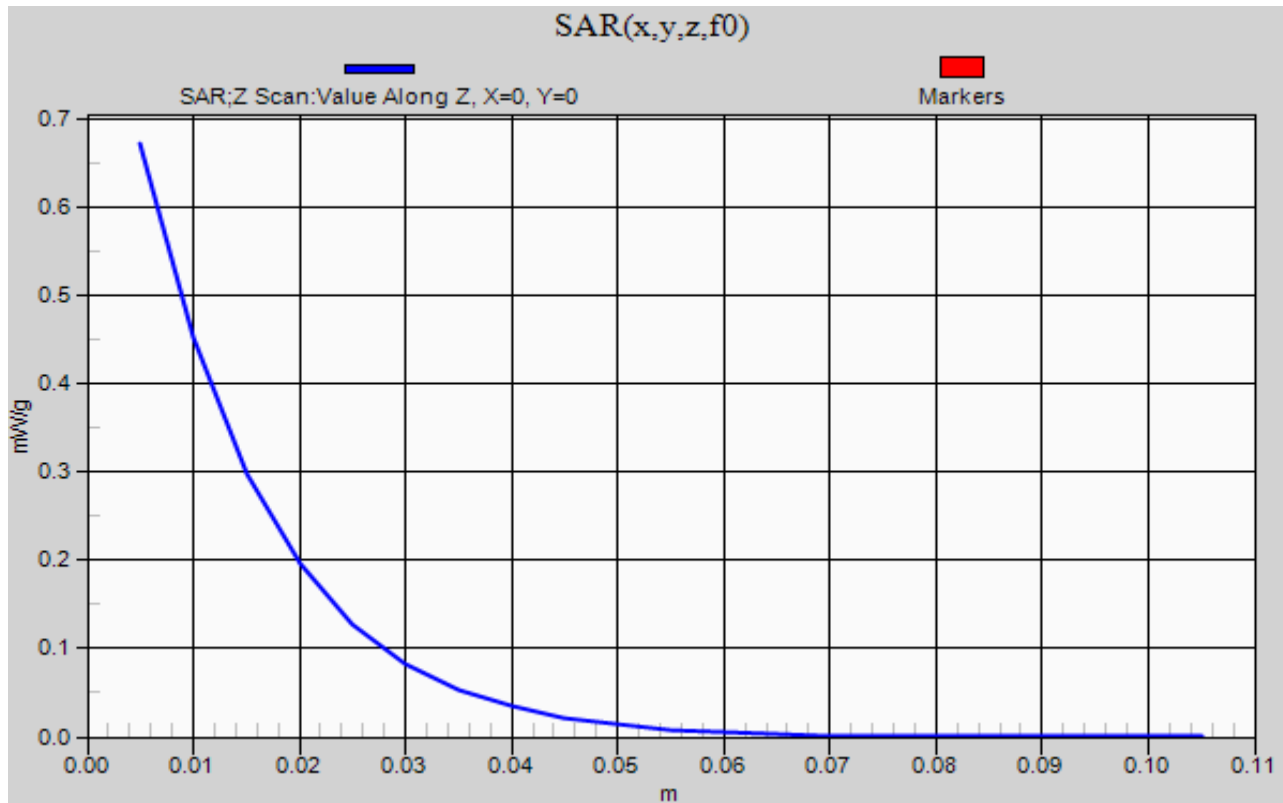

SAR Measurement System

Schmid & Partner Engineering AG, DASY52

Northwest EMC selected the leader in SAR evaluation systems to provide the measurement tools for this evaluation. SPEAG's DASY52 is the fastest and most accurate scanner on the market. It is fully compatible with all world-wide standards for transmitters operating at the ear or within 20cm of the body. It provides full compatibility with IEC 62209-1, IEC 62209-2, IEEE 1528 as well as national adaptations such as FCC OET-65c and Korean Std. MIC #2000-93

The DASY52 system for performing compliance tests consists of the following items:

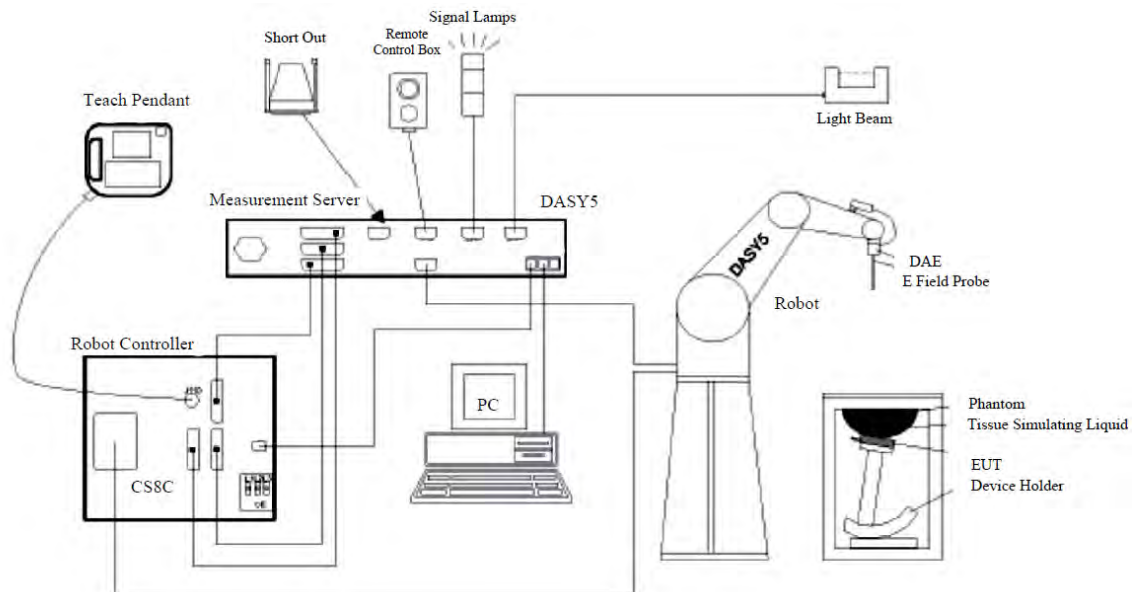

- A standard high precision 6-axis robot (Staubli TX=RX family) with controller, teach pendant and software. An arm extension for accommodating the data acquisition electronics (DAE).
- An isotropic field probe optimized and calibrated for the targeted measurement.
- A data acquisition electronics (DAE) which performs the signal amplification, signal multiplexing, AD-conversion, offset measurements, mechanical surface detection, collision detection, etc. The unit is battery powered with standard or rechargeable batteries. The signal is optically transmitted to the EOC.
- The Electro-optical converter (EOC) performs the conversion from optical to electrical signals for the digital communication to the DAE. To use optical surface detection, a special version of the EOC is required. The EOC signal is transmitted to the measurement server.
- The function of the measurement server is to perform the time critical tasks such as signal filtering, control of the robot operation and fast movement interrupts.
- The Light Beam used is for probe alignment. This improves the (absolute) accuracy of the probe positioning.
- A computer running WinXP and the DASY5 software.
- Remote control and teach pendant as well as additional circuitry for robot safety such as warning lamps, etc.
- The SAM twin phantom, oval flat phantom, device holder, tissue simulating liquids, and validation dipole kits.

Test Site

Northwest EMC, Lab EV08

The SAR measurement system is located in a semi-anechoic chamber. This provides an ambient free environment that also eliminates reflections.

The chamber is 12 ft wide by 16 ft long x 8 ft high. A dedicated HVAC unit provides +/- 1 degree C temperature control.



TEST EQUIPMENT					
Description	Manufacturer	Model	ID	Last Cal.	Interval
Wireless Communication Test Set	Agilent	E5515C	BSV	NCR	0 mo
Humidity Temperature Meter	Omegaette	HH311	DTY	3/29/2011	24 mo
Humidity Temperature Meter	Omegaette	HH311	DTX	3/29/2011	24 mo
Wideband Amplifier, SMA, 800-2000 MHz	Mini Circuits	ZHL-5W-2G-S+	TRZ	NCR	0 mo
MXG Analog Signal Generator	Agilent	N5181A	TIG	NCR	0 mo
Power Sensor	Agilent	E9300H	SQO	6/6/2011	24 mo
Power Meter	Agilent	N1913A	SQR	6/6/2011	24 mo
Dielectric Probe Kit	Agilent	85070E	IPP	9/8/2010	24 mo
Network Analyzer	Hewlett Packard	N5230A	NAD	8/3/2011	12 mo
Antenna, Dipole 1750MHz SAR	SPEAG	D1750v2	ADN	11/24/2010	12 mo
Antenna, Dipole 1900MHz SAR	SPEAG	D1900v2	ADO	11/24/2010	12 mo
Antenna, Dipole 835MHz SAR	SPEAG	D835V2	ADK	10/19/2010	12 mo
Device Holder	SPEAG	N/A	SAW	NCR	0 mo
Body Solution	SPEAG	MSL 900	SAT	Within 24 of hours of a measurement	
Head Solution	SPEAG	HSL 900	SAS		
Body Solution	SPEAG	MSL 1750	SAQ		
Head Solution	SPEAG	HSL 1750	SAP		
Body Solution	SPEAG	MSL 1900	SAO		
Head Solution	SPEAG	HSL 1900	SAN		
DASY5 Measurement Server	Staeubli	DAYS5	SAK	NCR	0 mo
Robot Chasis and power Supply	Staeubli	N/A	SAJ	NCR	0 mo
Robot Controller	Staeubli	CS8C	SAI	11/11/2010	12 mo
DAE	Schid & Partner Engineering	SD 000 D04 EJ	SAH	11/11/2010	12 mo
SAR Probe	SPEAG	ES3DV3	R035	2/23/2011	12 mo
SAR Probe	SPEAG	ES3DV3	SAF	11/11/2010	12 mo
Light Beam Unit	SPEAG	SE UKS 030 AA	SAD	NCR	0 mo
Phantom, 2mm Oval ELI4 (Body)	SPEAG	QD OVA 001 BB	SAC	NCR	0 mo
Phantom, Twin SAM (Head)	SPEAG	QD 000 P40 CC	SAB	NCR	0 mo
Robot Arm	Staeubli	TX60LSPEAG	SAA	NCR	0 mo

Measurement Uncertainty Budget per IEEE 1528:2003

300 – 3000 MHz range

Uncertainty Component	Tolerance (+/- %)	Probability Distribution	Divisor	c_i (1g)	c_i (10g)	u_i (1g) (+/-%)	u_i (10g) (+/-%)	v_i
Measurement System								
Probe calibration (k=1)	5.5	normal	1	1	1	5.5	5.5	∞
Axial isotropy	4.7	rectangular	1.732	0.707	0.707	1.9	1.9	∞
Hemispherical isotropy	9.6	rectangular	1.732	0.707	0.707	3.9	3.9	∞
Boundary effect	1.0	rectangular	1.732	1	1	0.6	0.6	∞
Linearity	4.7	rectangular	1.732	1	1	2.7	2.7	∞
System detection limits	1.0	rectangular	1.732	1	1	0.6	0.6	∞
Readout electronics	0.3	normal	1	1	1	0.3	0.3	∞
Response time	0.8	rectangular	1.732	1	1	0.5	0.5	∞
Integration time	2.6	rectangular	1.732	1	1	1.5	1.5	∞
RF ambient conditions - noise	1.7	rectangular	1.732	1	1	1.0	1.0	∞
RF Ambient Reflections	0.0	rectangular	1.732	1	1	0.0	0.0	∞
Probe positioner mechanical tolerance	0.4	rectangular	1.732	1	1	0.2	0.2	∞
Probe positioner with respect to phantom shell	2.9	rectangular	1.732	1	1	1.7	1.7	∞
Extrapolation, interpolation, and integration algorithms for max. SAR evaluation	1.0	rectangular	1.732	1	1	0.6	0.6	∞
Test Sample Related								
Device Positioning	2.9	normal	1	1	1	2.9	2.9	145
Device Holder	3.6	normal	1	1	1	3.6	3.6	5
Power Drift	5.0	rectangular	1.732	1	1	2.9	2.9	∞
Phantom and tissue parameters								
Phantom Uncertainty - shell thickness tolerances	4.0	rectangular	1.732	1	1	2.3	2.3	∞
Liquid conductivity - deviation from target values	5.0	rectangular	1.732	0.64	0.43	1.8	1.2	∞
Liquid conductivity - measurement uncertainty	6.5	normal	1	0.64	0.43	4.2	2.8	∞
Liquid permittivity - deviation from target values	5.0	rectangular	1.732	0.6	0.49	1.7	1.4	∞
Liquid permittivity - measurement uncertainty	3.2	normal	1	0.6	0.49	1.9	1.6	∞
Combined Standard Uncertainty	RSS					11.2	10.6	387
Expanded Measurement Uncertainty (95% Confidence/	normal (k=2)					22.5	21.2	

Probe Calibration

Please see attached calibration data

SAF

Calibration Laboratory of
 Schmid & Partner
 Engineering AG
 Zeughausstrasse 43, 8004 Zurich, Switzerland



S Schweizerischer Kalibrierdienst
S Service suisse d'étalonnage
C Servizio svizzero di taratura
S Swiss Calibration Service

Accredited by the Swiss Accreditation Service (SAS)
 The Swiss Accreditation Service is one of the signatories to the EA
 Multilateral Agreement for the recognition of calibration certificates

Accreditation No.: **SCS 108**

Client **Northwest EMC**

Certificate No: **ES3-3246_Nov10**

CALIBRATION CERTIFICATE

Object **ES3DV3 - SN:3246**

Calibration procedure(s) **QA CAL-01.v6, QA CAL-12.v6, QA CAL-23.v3 and QA CAL-25.v2
 Calibration procedure for dosimetric E-field probes**

Calibration date **November 11, 2010**

This calibration certificate documents the traceability to national standards, which realize the physical units of measurements (SI).
 The measurements and the uncertainties with confidence probability are given on the following pages and are part of the certificate.

All calibrations have been conducted in the closed laboratory facility: environment temperature $(22 \pm 3)^\circ\text{C}$ and humidity $< 70\%$.

Calibration Equipment used (M&TE critical for calibration)

Primary Standards	ID #	Cal Date (Certificate No.)	Scheduled Calibration
Power meter E4419B	GB41293874	1-Apr-10 (No. 217-01136)	Apr-11
Power sensor E4412A	MY41495277	1-Apr-10 (No. 217-01136)	Apr-11
Power sensor E4412A	MY41498087	1-Apr-10 (No. 217-01136)	Apr-11
Reference 3 dB Attenuator	SN: S5054 (3c)	30-Mar-10 (No. 217-01159)	Mar-11
Reference 20 dB Attenuator	SN: S5086 (20b)	30-Mar-10 (No. 217-01161)	Mar-11
Reference 30 dB Attenuator	SN: S5129 (30b)	30-Mar-10 (No. 217-01160)	Mar-11
Reference Probe ES3DV2	SN: 3013	30-Dec-09 (No. ES3-3013_Dec09)	Dec-10
DAE4	SN: 660	20-Apr-10 (No. DAE4-660_Apr10)	Apr-11

Secondary Standards	ID #	Check Date (in house)	Scheduled Check
RF generator HP 8648C	US3642U01700	4-Aug-99 (in house check Oct-09)	In house check: Oct-11
Network Analyzer HP 8753E	US37390585	18-Oct-01 (in house check Oct-10)	In house check: Oct-11

	Name	Function	Signature
Calibrated by:	Katja Pokovic	Technical Manager	
Approved by:	Niels Kuster	Quality Manager	

Issued: November 11, 2010

This calibration certificate shall not be reproduced except in full without written approval of the laboratory.



Accredited by the Swiss Accreditation Service (SAS)
The Swiss Accreditation Service is one of the signatories to the EA
Multilateral Agreement for the recognition of calibration certificates

Accreditation No.: **SCS 108**

Glossary:

TSL	tissue simulating liquid
NORM _{x,y,z}	sensitivity in free space
ConvF	sensitivity in TSL / NORM _{x,y,z}
DCP	diode compression point
CF	crest factor (1/duty_cycle) of the RF signal
A, B, C	modulation dependent linearization parameters
Polarization φ	φ rotation around probe axis
Polarization ϑ	ϑ rotation around an axis that is in the plane normal to probe axis (at measurement center), i.e., $\vartheta = 0$ is normal to probe axis

Calibration is Performed According to the Following Standards:

- IEEE Std 1528-2003, "IEEE Recommended Practice for Determining the Peak Spatial-Averaged Specific Absorption Rate (SAR) in the Human Head from Wireless Communications Devices: Measurement Techniques", December 2003
- IEC 62209-1, "Procedure to measure the Specific Absorption Rate (SAR) for hand-held devices used in close proximity to the ear (frequency range of 300 MHz to 3 GHz)", February 2005

Methods Applied and Interpretation of Parameters:

- NORM_{x,y,z}**: Assessed for E-field polarization $\vartheta = 0$ ($f \leq 900$ MHz in TEM-cell; $f > 1800$ MHz: R22 waveguide). NORM_{x,y,z} are only intermediate values, i.e., the uncertainties of NORM_{x,y,z} does not effect the E²-field uncertainty inside TSL (see below ConvF).
- NORM(f)_{x,y,z}** = NORM_{x,y,z} * *frequency_response* (see Frequency Response Chart). This linearization is implemented in DASY4 software versions later than 4.2. The uncertainty of the frequency response is included in the stated uncertainty of ConvF.
- DCP_{x,y,z}**: DCP are numerical linearization parameters assessed based on the data of power sweep with CW signal (no uncertainty required). DCP does not depend on frequency nor media.
- A_{x,y,z}; B_{x,y,z}; C_{x,y,z}; VR_{x,y,z}**: A, B, C are numerical linearization parameters assessed based on the data of power sweep for specific modulation signal. The parameters do not depend on frequency nor media. VR is the maximum calibration range expressed in RMS voltage across the diode.
- ConvF and Boundary Effect Parameters**: Assessed in flat phantom using E-field (or Temperature Transfer Standard for $f \leq 800$ MHz) and inside waveguide using analytical field distributions based on power measurements for $f > 800$ MHz. The same setups are used for assessment of the parameters applied for boundary compensation (alpha, depth) of which typical uncertainty values are given. These parameters are used in DASY4 software to improve probe accuracy close to the boundary. The sensitivity in TSL corresponds to NORM_{x,y,z} * ConvF whereby the uncertainty corresponds to that given for ConvF. A frequency dependent ConvF is used in DASY version 4.4 and higher which allows extending the validity from ± 50 MHz to ± 100 MHz.
- Spherical isotropy (3D deviation from isotropy)**: in a field of low gradients realized using a flat phantom exposed by a patch antenna.
- Sensor Offset**: The sensor offset corresponds to the offset of virtual measurement center from the probe tip (on probe axis). No tolerance required.

Probe ES3DV3

SN:3246

Manufactured:	May 5, 2009
Calibrated:	November 11, 2010

Calibrated for DASY/EASY Systems

(Note: non-compatible with DASY2 system!)

DASY/EASY - Parameters of Probe: ES3DV3 SN:3246

Basic Calibration Parameters

	Sensor X	Sensor Y	Sensor Z	Unc (k=2)
Norm ($\mu\text{V}/(\text{V}/\text{m})^2$) ^A	1.20	1.23	1.35	± 10.1%
DCP (mV) ^B	104.0	99.5	96.8	

Modulation Calibration Parameters

UID	Communication System Name	PAR		A dB	B dBuV	C	VR mV	Unc ^E (k=2)
10000	CW	0.00	X	0.00	0.00	1.00	148.7	± 2.6 %
			Y	0.00	0.00	1.00	148.9	
			Z	0.00	0.00	1.00	115.9	
10021	GSM-FDD (TDMA, GMSK)	9.20	X	3.88	71.01	17.64	85.2	± 3.7 %
			Y	9.08	82.29	21.95	92.0	
			Z	10.21	84.31	22.94	99.0	

The reported uncertainty of measurement is stated as the standard uncertainty of measurement multiplied by the coverage factor k=2, which for a normal distribution corresponds to a coverage probability of approximately 95%.

^A The uncertainties of NormX,Y,Z do not affect the E²-field uncertainty inside TSL (see Pages 5 and 6).

^B Numerical linearization parameter: uncertainty not required.

^E Uncertainty is determined using the maximum deviation from linear response applying rectangular distribution and is expressed for the square of the field value.

DASY/EASY - Parameters of Probe: ES3DV3 SN:3246

Calibration Parameter Determined in Head Tissue Simulating Media

f [MHz]	Validity [MHz] ^c	Permittivity	Conductivity	ConvF X	ConvF Y	ConvF Z	Alpha	Depth Unc (k=2)
835	± 50 / ± 100	41.5 ± 5%	0.90 ± 5%	6.04	6.04	6.04	0.62	1.57 ± 11.0%
900	± 50 / ± 100	41.5 ± 5%	0.97 ± 5%	6.06	6.06	6.06	0.99	1.10 ± 11.0%
1750	± 50 / ± 100	40.1 ± 5%	1.37 ± 5%	5.21	5.21	5.21	0.72	0.90 ± 11.0%
1900	± 50 / ± 100	40.0 ± 5%	1.40 ± 5%	5.02	5.02	5.02	0.82	0.95 ± 11.0%

^c The validity of ± 100 MHz only applies for DASY v4.4 and higher (see Page 2). The uncertainty is the RSS of the ConvF uncertainty at calibration frequency and the uncertainty for the indicated frequency band.

DASY/EASY - Parameters of Probe: ES3DV3 SN:3246

Calibration Parameter Determined in Body Tissue Simulating Media

f [MHz]	Validity [MHz] ^c	Permittivity	Conductivity	ConvF X	ConvF Y	ConvF Z	Alpha	Depth Unc (k=2)
450	± 50 / ± 100	56.7 ± 5%	0.94 ± 5%	7.00	7.00	7.00	0.07	1.00 ± 13.3%
835	± 50 / ± 100	55.2 ± 5%	0.97 ± 5%	6.10	6.10	6.10	0.99	1.20 ± 11.0%
900	± 50 / ± 100	55.0 ± 5%	1.05 ± 5%	6.01	6.01	6.01	0.99	1.18 ± 11.0%
1750	± 50 / ± 100	53.4 ± 5%	1.49 ± 5%	4.85	4.85	4.85	0.98	0.95 ± 11.0%
1900	± 50 / ± 100	53.3 ± 5%	1.52 ± 5%	4.63	4.63	4.63	0.84	1.00 ± 11.0%

^c The validity of ± 100 MHz only applies for DASY v4 4 and higher (see Page 2). The uncertainty is the RSS of the ConvF uncertainty at calibration frequency and the uncertainty for the indicated frequency band

Frequency Response of E-Field

(TEM-Cell:ifi110 EXX, Waveguide: R22)

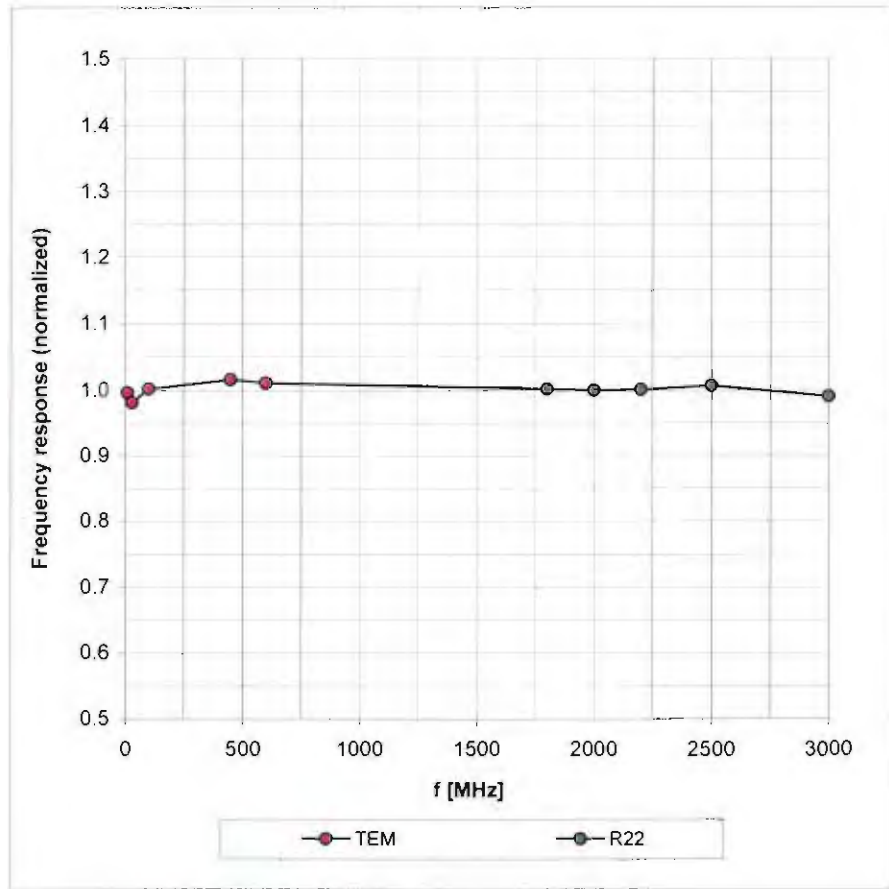

Uncertainty of Frequency Response of E-field: $\pm 6.3\%$ ($k=2$)

Receiving Pattern (ϕ), $\vartheta = 0^\circ$

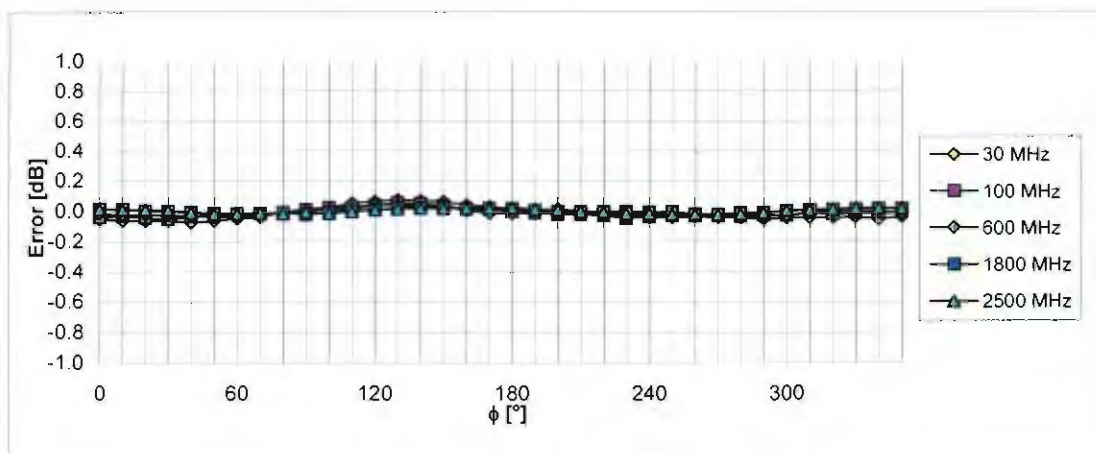
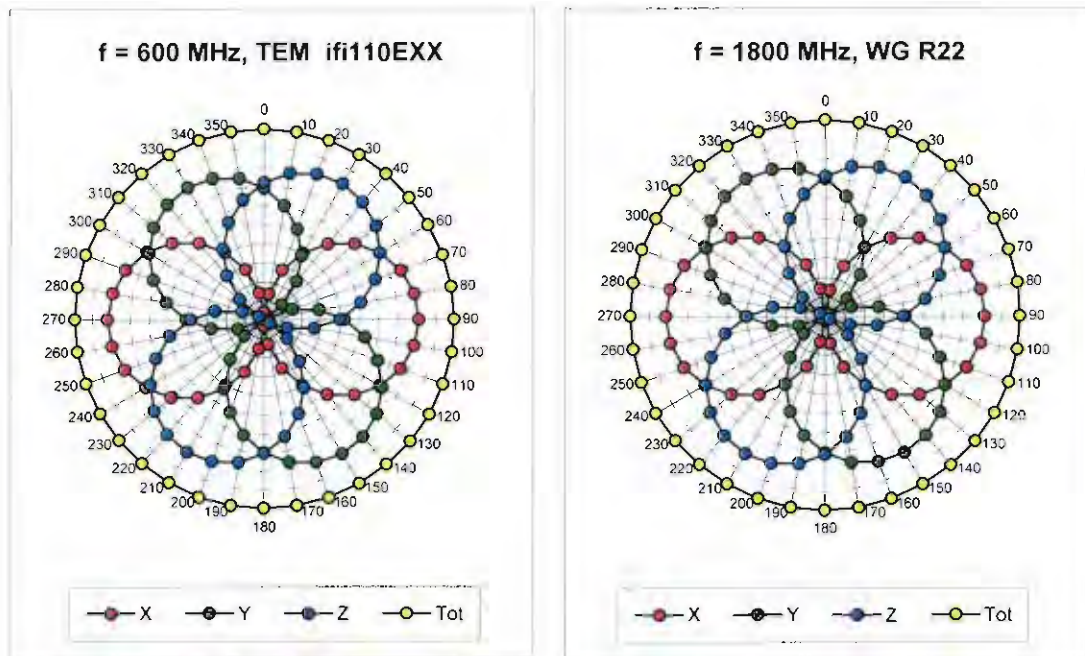

Uncertainty of Axial Isotropy Assessment: $\pm 0.5\%$ ($k=2$)

Dynamic Range $f(\text{SAR}_{\text{head}})$ (Waveguide R22, $f = 1800 \text{ MHz}$)

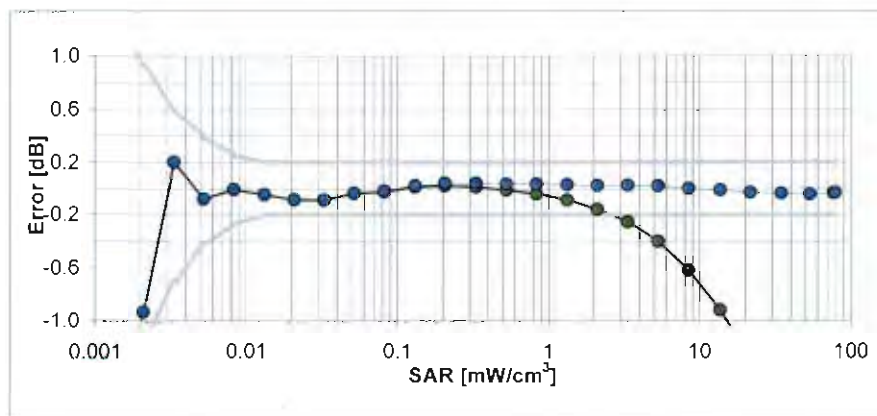
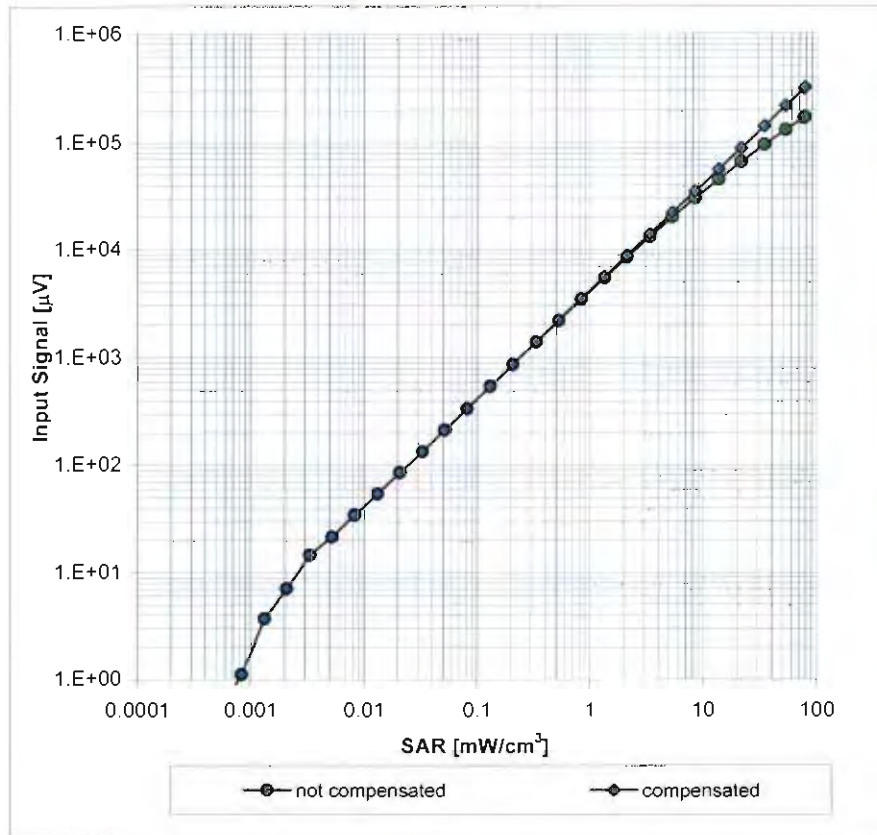

Uncertainty of Linearity Assessment: $\pm 0.6\%$ ($k=2$)

Conversion Factor Assessment

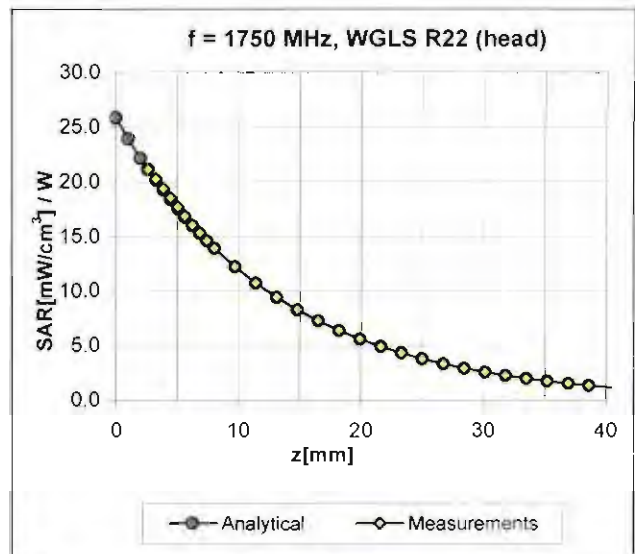
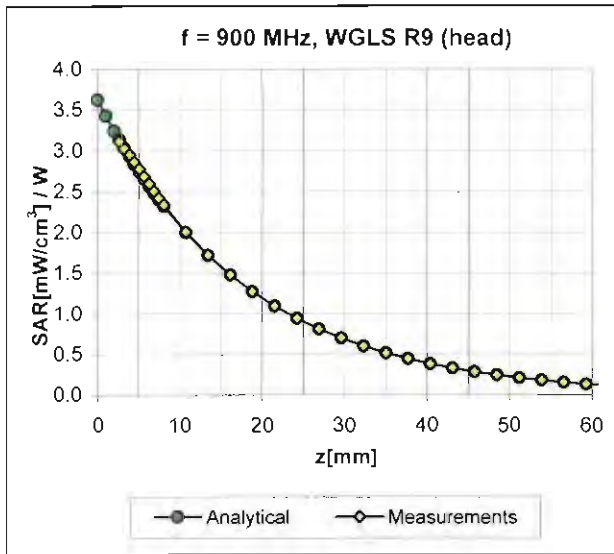

Deviation from Isotropy in HSL

Error (ϕ , θ), f = 900 MHz

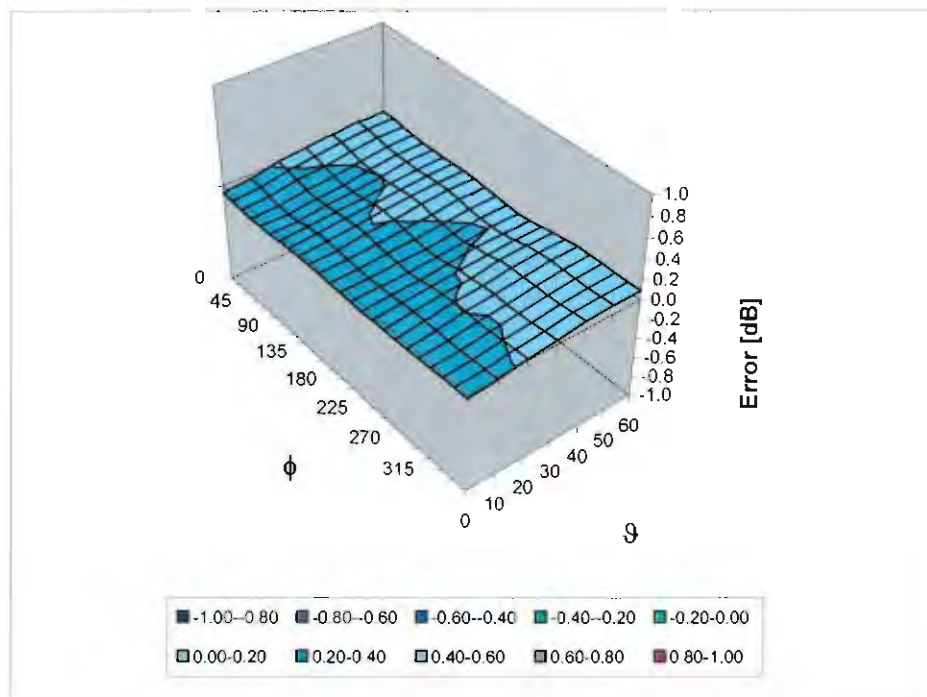

Uncertainty of Spherical Isotropy Assessment: $\pm 2.6\%$ (k=2)

Other Probe Parameters

Sensor Arrangement	Triangular
Connector Angle (°)	Not applicable
Mechanical Surface Detection Mode	enabled
Optical Surface Detection Mode	disabled
Probe Overall Length	337 mm
Probe Body Diameter	10 mm
Tip Length	10 mm
Tip Diameter	4.0 mm
Probe Tip to Sensor X Calibration Point	2 mm
Probe Tip to Sensor Y Calibration Point	2 mm
Probe Tip to Sensor Z Calibration Point	2 mm
Recommended Measurement Distance from Surface	3 mm

**Calibration Laboratory of
Schmid & Partner
Engineering AG**
Zeughausstrasse 43, 8004 Zurich, Switzerland



**S
C
S** Schweizerischer Kalibrierdienst
Service suisse d'étalonnage
Servizio svizzero di taratura
Swiss Calibration Service

Accredited by the Swiss Accreditation Service (SAS)
The Swiss Accreditation Service is one of the signatories to the EA
Multilateral Agreement for the recognition of calibration certificates

Accreditation No.: **SCS 108**

Client **SPEAG Replacement**

Certificate No: **ES3-3173_Feb11**

CALIBRATION CERTIFICATE

Object **ES3DV3 - SN:3173**

Calibration procedure(s) **QA CAL-01.v7, QA CAL-23.v4, QA CAL-25.v3
Calibration procedure for dosimetric E-field probes**

Calibration date: **February 23, 2011**

This calibration certificate documents the traceability to national standards, which realize the physical units of measurements (SI).
The measurements and the uncertainties with confidence probability are given on the following pages and are part of the certificate.

All calibrations have been conducted in the closed laboratory facility: environment temperature (22 ± 3)°C and humidity < 70%.

Calibration Equipment used (M&TE critical for calibration)

Primary Standards	ID	Cal Date (Certificate No.)	Scheduled Calibration
Power meter E4419B	GB41293874	01-Apr-10 (No. 217-01136)	Apr-11
Power sensor E4412A	MY41495277	01-Apr-10 (No. 217-01136)	Apr-11
Power sensor E4412A	MY41498087	01-Apr-10 (No. 217-01136)	Apr-11
Reference 3 dB Attenuator	SN: S5054 (3c)	30-Mar-10 (No. 217-01159)	Mar-11
Reference 20 dB Attenuator	SN: S5086 (20b)	30-Mar-10 (No. 217-01161)	Mar-11
Reference 30 dB Attenuator	SN: S5129 (30b)	30-Mar-10 (No. 217-01160)	Mar-11
Reference Probe ES3DV2	SN: 3013	29-Dec-10 (No. ES3-3013_Dec10)	Dec-11
DAE4	SN: 654	23-Apr-10 (No. DAE4-654_Apr10)	Apr-11
Secondary Standards	ID	Check Date (in house)	Scheduled Check
RF generator HP 8648C	US3642U01700	4-Aug-99 (in house check Oct-09)	In house check: Oct-11
Network Analyzer HP 8753E	US37390585	18-Oct-01 (in house check Oct-10)	In house check: Oct-11

Calibrated by:	Name Claudio Leubler	Function Laboratory Technician	Signature
Approved by:	Name Katja Pokovic	Function Technical Manager	Signature

Issued: February 24, 2011

This calibration certificate shall not be reproduced except in full without written approval of the laboratory.



Accredited by the Swiss Accreditation Service (SAS)

Accreditation No.: **SCS 108**

The Swiss Accreditation Service is one of the signatories to the EA
Multilateral Agreement for the recognition of calibration certificates

Glossary:

TSL	tissue simulating liquid
NORM _{x,y,z}	sensitivity in free space
ConvF	sensitivity in TSL / NORM _{x,y,z}
DCP	diode compression point
CF	crest factor (1/duty_cycle) of the RF signal
A, B, C	modulation dependent linearization parameters
Polarization φ	φ rotation around probe axis
Polarization ϑ	ϑ rotation around an axis that is in the plane normal to probe axis (at measurement center), i.e., $\vartheta = 0$ is normal to probe axis

Calibration is Performed According to the Following Standards:

- IEEE Std 1528-2003, "IEEE Recommended Practice for Determining the Peak Spatial-Averaged Specific Absorption Rate (SAR) in the Human Head from Wireless Communications Devices: Measurement Techniques", December 2003
- IEC 62209-1, "Procedure to measure the Specific Absorption Rate (SAR) for hand-held devices used in close proximity to the ear (frequency range of 300 MHz to 3 GHz)", February 2005

Methods Applied and Interpretation of Parameters:

- NORM_{x,y,z}**: Assessed for E-field polarization $\vartheta = 0$ ($f \leq 900$ MHz in TEM-cell; $f > 1800$ MHz: R22 waveguide). NORM_{x,y,z} are only intermediate values, i.e., the uncertainties of NORM_{x,y,z} does not affect the E²-field uncertainty inside TSL (see below ConvF).
- NORM(f)_{x,y,z}** = NORM_{x,y,z} * frequency_response (see Frequency Response Chart). This linearization is implemented in DASY4 software versions later than 4.2. The uncertainty of the frequency response is included in the stated uncertainty of ConvF.
- DCP_{x,y,z}**: DCP are numerical linearization parameters assessed based on the data of power sweep with CW signal (no uncertainty required). DCP does not depend on frequency nor media.
- PAR**: PAR is the Peak to Average Ratio that is not calibrated but determined based on the signal characteristics
- A_{x,y,z}; B_{x,y,z}; C_{x,y,z}; VR_{x,y,z}; A, B, C** are numerical linearization parameters assessed based on the data of power sweep for specific modulation signal. The parameters do not depend on frequency nor media. VR is the maximum calibration range expressed in RMS voltage across the diode.
- ConvF and Boundary Effect Parameters**: Assessed in flat phantom using E-field (or Temperature Transfer Standard for $f \leq 800$ MHz) and inside waveguide using analytical field distributions based on power measurements for $f > 800$ MHz. The same setups are used for assessment of the parameters applied for boundary compensation (alpha, depth) of which typical uncertainty values are given. These parameters are used in DASY4 software to improve probe accuracy close to the boundary. The sensitivity in TSL corresponds to NORM_{x,y,z} * ConvF whereby the uncertainty corresponds to that given for ConvF. A frequency dependent ConvF is used in DASY version 4.4 and higher which allows extending the validity from ± 50 MHz to ± 100 MHz.
- Spherical isotropy (3D deviation from isotropy)**: in a field of low gradients realized using a flat phantom exposed by a patch antenna.
- Sensor Offset**: The sensor offset corresponds to the offset of virtual measurement center from the probe tip (on probe axis). No tolerance required.

Probe ES3DV3

SN:3173

Manufactured: January 23, 2008
Calibrated: February 23, 2011

Calibrated for DASYS/EASY Systems
(Note: non-compatible with DASYS2 system!)

DASY/EASY - Parameters of Probe: ES3DV3 - SN:3173

Basic Calibration Parameters

	Sensor X	Sensor Y	Sensor Z	Unc (k=2)
Norm ($\mu\text{V}/(\text{V}/\text{m})^2$) ^A	1.21	1.28	1.35	$\pm 10.1\%$
DCP (mV) ^B	95.9	100.2	100.8	

Modulation Calibration Parameters

UID	Communication System Name	PAR		A dB	B dB	C dB	VR mV	Unc ^E (k=2)
10000	CW	0.00	X	0.00	0.00	1.00	144.1	$\pm 2.7\%$
			Y	0.00	0.00	1.00	114.9	
			Z	0.00	0.00	1.00	113.4	

The reported uncertainty of measurement is stated as the standard uncertainty of measurement multiplied by the coverage factor $k=2$, which for a normal distribution corresponds to a coverage probability of approximately 95%.

^A The uncertainties of NormX,Y,Z do not affect the E^2 -field uncertainty inside TSL (see Pages 5 and 6).

^B Numerical linearization parameter; uncertainty not required.

^E Uncertainty is determined using the max. deviation from linear response applying rectangular distribution and is expressed for the square of the field value.

DASY/EASY - Parameters of Probe: ES3DV3 - SN:3173

Calibration Parameter Determined in Head Tissue Simulating Media

f (MHz) ^C	Relative Permittivity ^F	Conductivity (S/m) ^F	ConvF X	ConvF Y	ConvF Z	Alpha	Depth (mm)	Unct. (k=2)
750	41.9	0.89	6.25	6.25	6.25	0.99	1.11	± 12.0 %
835	41.5	0.90	6.01	6.01	6.01	0.99	1.12	± 12.0 %
900	41.5	0.97	5.93	5.93	5.93	0.99	1.12	± 12.0 %
1640	40.3	1.29	5.34	5.34	5.34	0.99	1.11	± 12.0 %
1750	40.1	1.37	5.20	5.20	5.20	0.99	1.13	± 12.0 %
1810	40.0	1.40	5.05	5.05	5.05	0.94	1.15	± 12.0 %
1900	40.0	1.40	4.96	4.96	4.96	0.96	1.13	± 12.0 %
1950	40.0	1.40	4.80	4.80	4.80	0.91	1.17	± 12.0 %
2000	40.0	1.40	4.88	4.88	4.88	0.99	1.06	± 12.0 %
2150	39.7	1.53	4.72	4.72	4.72	0.95	1.13	± 12.0 %
2300	39.5	1.67	4.58	4.58	4.58	0.96	1.09	± 12.0 %
2450	39.2	1.80	4.26	4.26	4.26	0.92	1.14	± 12.0 %
2600	39.0	1.96	4.13	4.13	4.13	0.90	1.16	± 12.0 %

^C Frequency validity of ± 100 MHz only applies for DASY v4.4 and higher (see Page 2), else it is restricted to ± 50 MHz. The uncertainty is the RSS of the ConvF uncertainty at calibration frequency and the uncertainty for the indicated frequency band.

^F At frequencies below 3 GHz, the validity of tissue parameters (ϵ and σ) can be relaxed to ± 10% if liquid compensation formula is applied to measured SAR values. At frequencies above 3 GHz, the validity of tissue parameters (ϵ and σ) is restricted to ± 5%. The uncertainty is the RSS of the ConvF uncertainty for indicated target tissue parameters.

DASY/EASY - Parameters of Probe: ES3DV3- SN:3173

Calibration Parameter Determined in Body Tissue Simulating Media

f (MHz) ^C	Relative Permittivity ^F	Conductivity (S/m) ^F	ConvF X	ConvF Y	ConvF Z	Alpha	Depth (mm)	Unct. (k=2)
750	55.5	0.96	6.01	6.01	6.01	0.99	1.15	± 12.0 %
835	55.2	0.97	5.97	5.97	5.97	0.99	1.16	± 12.0 %
900	55.0	1.05	5.89	5.89	5.89	0.99	1.14	± 12.0 %
1640	53.8	1.40	5.30	5.30	5.30	0.99	1.18	± 12.0 %
1750	53.4	1.49	4.87	4.87	4.87	0.95	1.22	± 12.0 %
1810	53.3	1.52	4.71	4.71	4.71	0.95	1.20	± 12.0 %
1900	53.3	1.52	4.55	4.55	4.55	0.90	1.24	± 12.0 %
1950	53.3	1.52	4.61	4.61	4.61	0.93	1.20	± 12.0 %
2000	53.3	1.52	4.49	4.49	4.49	0.89	1.24	± 12.0 %
2150	53.1	1.66	4.37	4.37	4.37	0.98	1.16	± 12.0 %
2300	52.9	1.81	4.19	4.19	4.19	0.99	1.08	± 12.0 %
2450	52.7	1.95	4.05	4.05	4.05	0.99	1.01	± 12.0 %
2600	52.5	2.16	3.90	3.90	3.90	0.99	1.03	± 12.0 %

^C Frequency validity of ± 100 MHz only applies for DASY v4.4 and higher (see Page 2), else it is restricted to ± 50 MHz. The uncertainty is the RSS of the ConvF uncertainty at calibration frequency and the uncertainty for the indicated frequency band.

^F At frequencies below 3 GHz, the validity of tissue parameters (ϵ and σ) can be relaxed to ± 10% if liquid compensation formula is applied to measured SAR values. At frequencies above 3 GHz, the validity of tissue parameters (ϵ and σ) is restricted to ± 5%. The uncertainty is the RSS of the ConvF uncertainty for indicated target tissue parameters.

Frequency Response of E-Field (TEM-Cell:ifi110 EXX, Waveguide: R22)

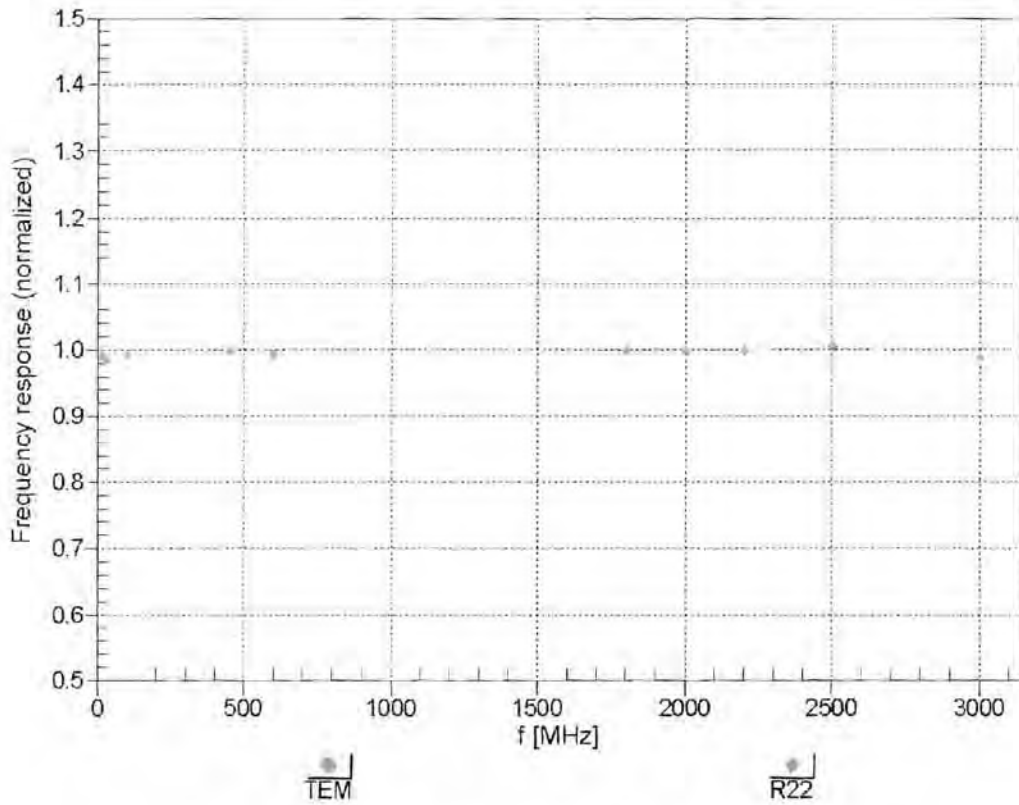

Uncertainty of Frequency Response of E-field: $\pm 6.3\%$ (k=2)

Receiving Pattern (ϕ), $\theta = 0^\circ$

f=600 MHz,TEM

f=1800 MHz,R22

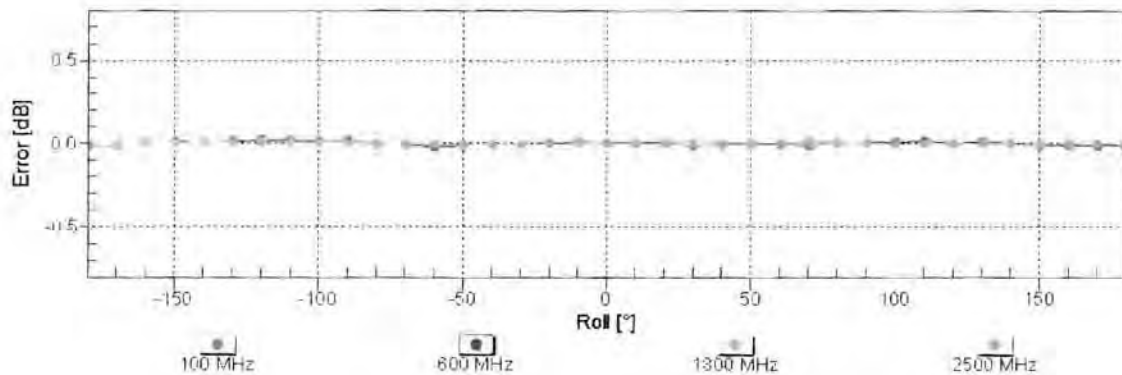
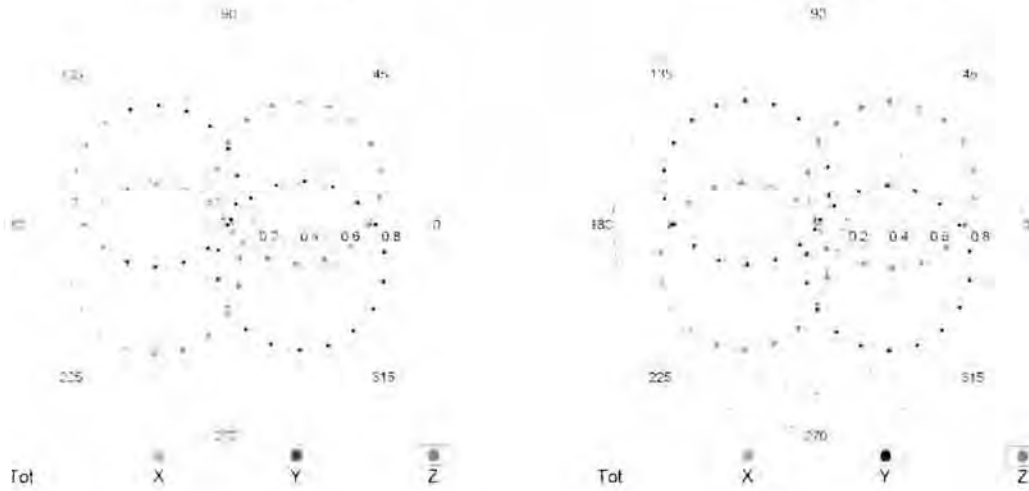

Uncertainty of Axial Isotropy Assessment: $\pm 0.5\%$ ($k=2$)

Dynamic Range $f(SAR_{head})$ (TEM cell, $f = 900$ MHz)

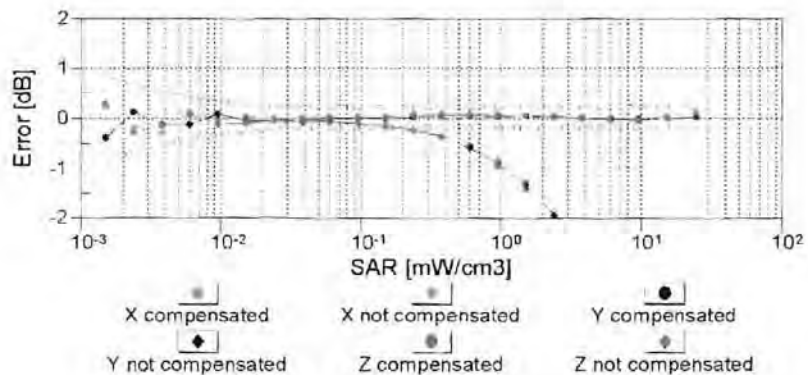
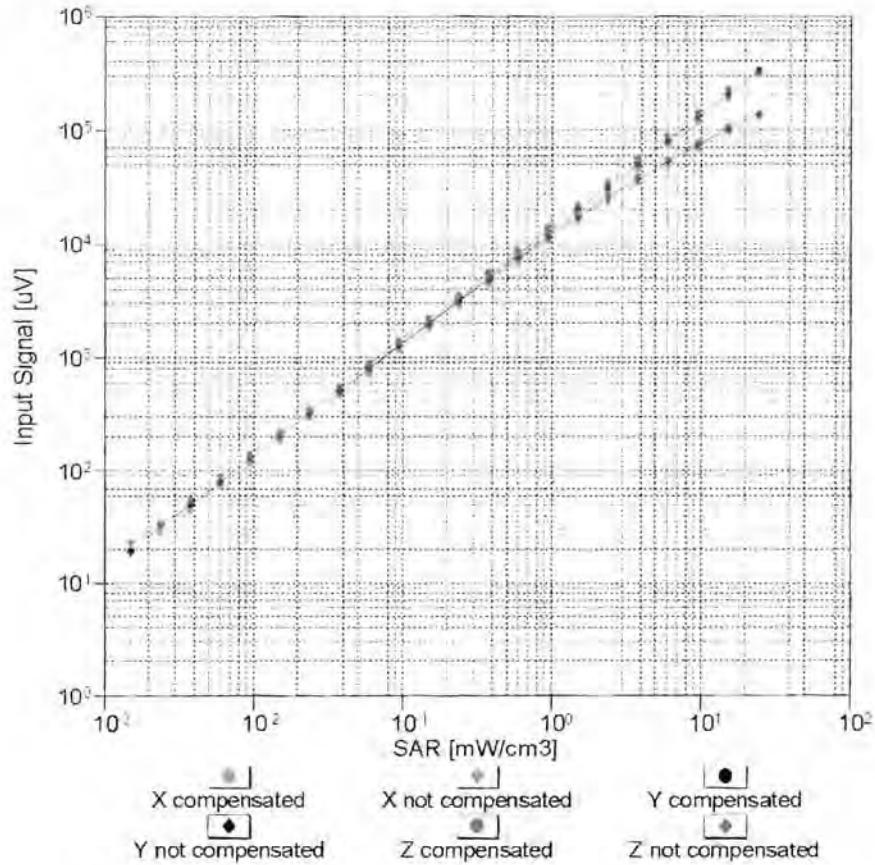

Uncertainty of Linearity Assessment: $\pm 0.6\%$ ($k=2$)

Conversion Factor Assessment

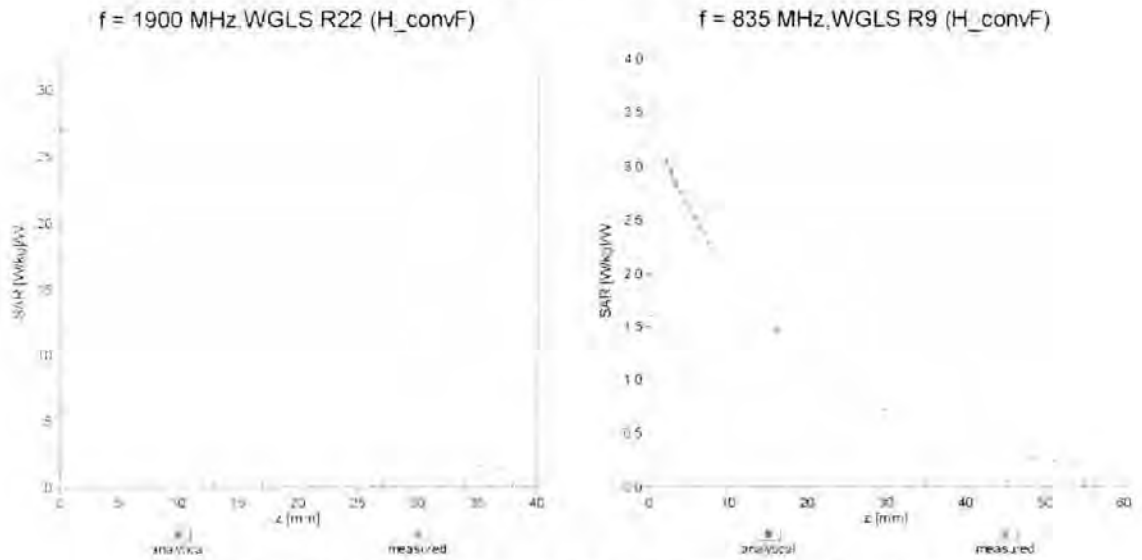

Deviation from Isotropy in Liquid

Error (ϕ, θ), f = 900 MHz

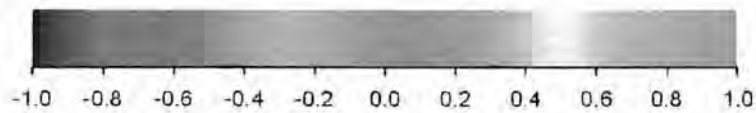
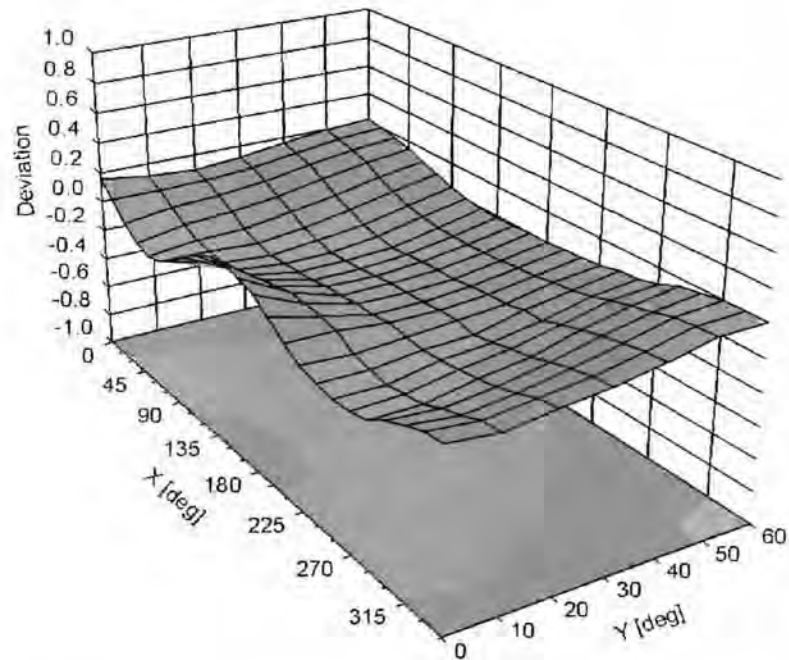

Uncertainty of Spherical Isotropy Assessment: $\pm 2.6\%$ (k=2)

DASY/EASY - Parameters of Probe: ES3DV3 - SN:3173**Other Probe Parameters**

Sensor Arrangement	Triangular
Connector Angle (°)	Not applicable
Mechanical Surface Detection Mode	enabled
Optical Surface Detection Mode	disabled
Probe Overall Length	337 mm
Probe Body Diameter	10 mm
Tip Length	10 mm
Tip Diameter	4 mm
Probe Tip to Sensor X Calibration Point	2 mm
Probe Tip to Sensor Y Calibration Point	2 mm
Probe Tip to Sensor Z Calibration Point	2 mm
Recommended Measurement Distance from Surface	3 mm

Dipole Calibration

Please see attached calibration data

**Calibration Laboratory of
Schmid & Partner
Engineering AG**
Zeughausstrasse 43, 8004 Zurich, Switzerland



S Schweizerischer Kalibrierdienst
S Service suisse d'étalonnage
C Servizio svizzero di taratura
S Swiss Calibration Service

Accredited by the Swiss Accreditation Service (SAS)
The Swiss Accreditation Service is one of the signatories to the EA
Multilateral Agreement for the recognition of calibration certificates

Accreditation No.: **SCS 108**

Client **Northwest EMC**

Certificate No: **D835V2-4d108_Oct10**

CALIBRATION CERTIFICATE

Object **D835V2 - SN: 4d108**

Calibration procedure(s) **QA CAL-05.v7
Calibration procedure for dipole validation kits**

Calibration date: **October 19, 2010**

This calibration certificate documents the traceability to national standards, which realize the physical units of measurements (SI).
The measurements and the uncertainties with confidence probability are given on the following pages and are part of the certificate.

All calibrations have been conducted in the closed laboratory facility: environment temperature (22 ± 3)°C and humidity < 70%.

Calibration Equipment used (M&TE critical for calibration)

Primary Standards	ID #	Cal Date (Certificate No.)	Scheduled Calibration
Power meter EPM-442A	GB37480704	06-Oct-10 (No. 217-01266)	Oct-11
Power sensor HP 8481A	US37292783	06-Oct-10 (No. 217-01266)	Oct-11
Reference 20 dB Attenuator	SN: 5086 (20g)	30-Mar-10 (No. 217-01158)	Mar-11
Type-N mismatch combination	SN: 5047.2 / 06327	30-Mar-10 (No. 217-01162)	Mar-11
Reference Probe ES3DV3	SN: 3205	30-Apr-10 (No. ES3-3205_Apr10)	Apr-11
DAE4	SN: 601	10-Jun-10 (No. DAE4-601_Jun10)	Jun-11
Secondary Standards	ID #	Check Date (in house)	Scheduled Check
Power sensor HP 8481A	MY41092317	18-Oct-02 (in house check Oct-09)	In house check: Oct-11
RF generator R&S SMT-06	100005	4-Aug-99 (in house check Oct-09)	In house check: Oct-11
Network Analyzer HP 8753E	US37390585 S4206	18-Oct-01 (in house check Oct-10)	In house check: Oct-11

	Name	Function	Signature
Calibrated by:	Dimce Iliev	Laboratory Technician	
Approved by:	Katja Pokovic	Technical Manager	

Issued: October 19, 2010

This calibration certificate shall not be reproduced except in full without written approval of the laboratory.



Accredited by the Swiss Accreditation Service (SAS)
The Swiss Accreditation Service is one of the signatories to the EA
Multilateral Agreement for the recognition of calibration certificates

Accreditation No.: **SCS 108**

Glossary:

TSL	tissue simulating liquid
ConvF	sensitivity in TSL / NORM x,y,z
N/A	not applicable or not measured

Calibration is Performed According to the Following Standards:

- a) IEEE Std 1528-2003, "IEEE Recommended Practice for Determining the Peak Spatial-Averaged Specific Absorption Rate (SAR) in the Human Head from Wireless Communications Devices: Measurement Techniques", December 2003
- b) IEC 62209-1, "Procedure to measure the Specific Absorption Rate (SAR) for hand-held devices used in close proximity to the ear (frequency range of 300 MHz to 3 GHz)", February 2005
- c) Federal Communications Commission Office of Engineering & Technology (FCC OET), "Evaluating Compliance with FCC Guidelines for Human Exposure to Radiofrequency Electromagnetic Fields; Additional Information for Evaluating Compliance of Mobile and Portable Devices with FCC Limits for Human Exposure to Radiofrequency Emissions", Supplement C (Edition 01-01) to Bulletin 65

Additional Documentation:

- d) DASY4/5 System Handbook

Methods Applied and Interpretation of Parameters:

- *Measurement Conditions:* Further details are available from the Validation Report at the end of the certificate. All figures stated in the certificate are valid at the frequency indicated.
- *Antenna Parameters with TSL:* The dipole is mounted with the spacer to position its feed point exactly below the center marking of the flat phantom section, with the arms oriented parallel to the body axis.
- *Feed Point Impedance and Return Loss:* These parameters are measured with the dipole positioned under the liquid filled phantom. The impedance stated is transformed from the measurement at the SMA connector to the feed point. The Return Loss ensures low reflected power. No uncertainty required.
- *Electrical Delay:* One-way delay between the SMA connector and the antenna feed point. No uncertainty required.
- *SAR measured:* SAR measured at the stated antenna input power.
- *SAR normalized:* SAR as measured, normalized to an input power of 1 W at the antenna connector.
- *SAR for nominal TSL parameters:* The measured TSL parameters are used to calculate the nominal SAR result.

Measurement Conditions

DASY system configuration, as far as not given on page 1.

DASY Version	DASY5	V52.2
Extrapolation	Advanced Extrapolation	
Phantom	Modular Flat Phantom V4.9	
Distance Dipole Center - TSL	15 mm	with Spacer
Zoom Scan Resolution	dx, dy, dz = 5 mm	
Frequency	835 MHz \pm 1 MHz	

Head TSL parameters

The following parameters and calculations were applied.

	Temperature	Permittivity	Conductivity
Nominal Head TSL parameters	22.0 °C	41.5	0.90 mho/m
Measured Head TSL parameters	(22.0 \pm 0.2) °C	42.3 \pm 6 %	0.90 mho/m \pm 6 %
Head TSL temperature during test	(22.0 \pm 0.2) °C	----	----

SAR result with Head TSL

SAR averaged over 1 cm ³ (1 g) of Head TSL	Condition	
SAR measured	250 mW input power	2.40 mW / g
SAR normalized	normalized to 1W	9.60 mW / g
SAR for nominal Head TSL parameters	normalized to 1W	9.64 mW / g \pm 17.0 % (k=2)

SAR averaged over 10 cm ³ (10 g) of Head TSL	condition	
SAR measured	250 mW input power	1.57 mW / g
SAR normalized	normalized to 1W	6.28 mW / g
SAR for nominal Head TSL parameters	normalized to 1W	6.29 mW / g \pm 16.5 % (k=2)

Body TSL parameters

The following parameters and calculations were applied.

	Temperature	Permittivity	Conductivity
Nominal Body TSL parameters	22.0 °C	55.2	0.97 mho/m
Measured Body TSL parameters	(22.0 ± 0.2) °C	54.4 ± 6 %	0.99 mho/m ± 6 %
Body TSL temperature during test	(21.8 ± 0.2) °C	----	----

SAR result with Body TSL

SAR averaged over 1 cm ³ (1 g) of Body TSL	Condition	
SAR measured	250 mW input power	2.53 mW / g
SAR normalized	normalized to 1W	10.1 mW / g
SAR for nominal Body TSL parameters	normalized to 1W	9.93 mW / g ± 17.0 % (k=2)

SAR averaged over 10 cm ³ (10 g) of Body TSL	condition	
SAR measured	250 mW input power	1.65 mW / g
SAR normalized	normalized to 1W	6.60 mW / g
SAR for nominal Body TSL parameters	normalized to 1W	6.51 mW / g ± 16.5 % (k=2)

Appendix

Antenna Parameters with Head TSL

Impedance, transformed to feed point	51.8 Ω - 3.2 j Ω
Return Loss	- 28.8 dB

Antenna Parameters with Body TSL

Impedance, transformed to feed point	48.0 Ω - 4.4 j Ω
Return Loss	- 26.2 dB

General Antenna Parameters and Design

Electrical Delay (one direction)	1.396 ns
----------------------------------	----------

After long term use with 100W radiated power, only a slight warming of the dipole near the feedpoint can be measured.

The dipole is made of standard semirigid coaxial cable. The center conductor of the feeding line is directly connected to the second arm of the dipole. The antenna is therefore short-circuited for DC-signals.

No excessive force must be applied to the dipole arms, because they might bend or the soldered connections near the feedpoint may be damaged.

Additional EUT Data

Manufactured by	SPEAG
Manufactured on	May 26, 2010

DASY5 Validation Report for Head TSL

Date/Time: 18.10.2010 12:32:33

Test Laboratory: SPEAG, Zurich, Switzerland

DUT: Dipole 835 MHz; Type: D835V2; Serial: D835V2 - SN:4d108

Communication System: CW; Frequency: 835 MHz; Duty Cycle: 1:1

Medium: HSL900

Medium parameters used: $f = 835$ MHz; $\sigma = 0.9$ mho/m; $\epsilon_r = 42.3$; $\rho = 1000$ kg/m³

Phantom section: Flat Section

Measurement Standard: DASY5 (IEEE/IEC/ANSI C63.19-2007)

DASY5 Configuration:

- Probe: ES3DV3 - SN3205; ConvF(6.03, 6.03, 6.03); Calibrated: 30.04.2010
- Sensor-Surface: 3mm (Mechanical Surface Detection)
- Electronics: DAE4 Sn601; Calibrated: 10.06.2010
- Phantom: Flat Phantom 4.9L; Type: QD000P49AA; Serial: 1001
- Measurement SW: DASY52, V52.2 Build 0, Version 52.2.0 (163)
- Postprocessing SW: SEMCAD X, V14.2 Build 2, Version 14.2.2 (1685)

Pin=250 mW /d=15mm, dist=3.0mm (ES-Probe)/Zoom Scan (7x7x7) /Cube 0: Measurement grid: dx=5mm, dy=5mm, dz=5mm

Reference Value = 57.1 V/m; Power Drift = 0.000575 dB

Peak SAR (extrapolated) = 3.61 W/kg

SAR(1 g) = 2.4 mW/g; SAR(10 g) = 1.57 mW/g

Maximum value of SAR (measured) = 2.77 mW/g

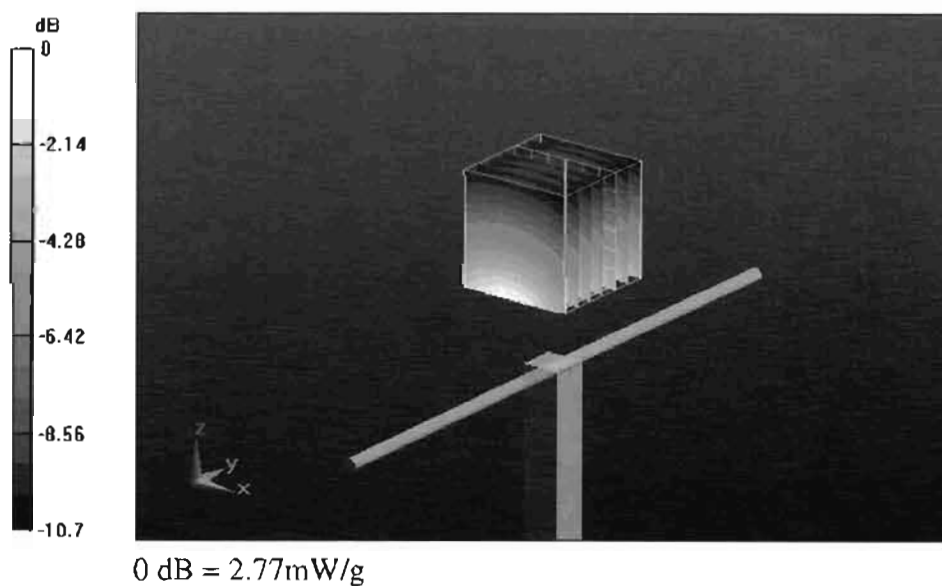

Impedance Measurement Plot for Head TSL

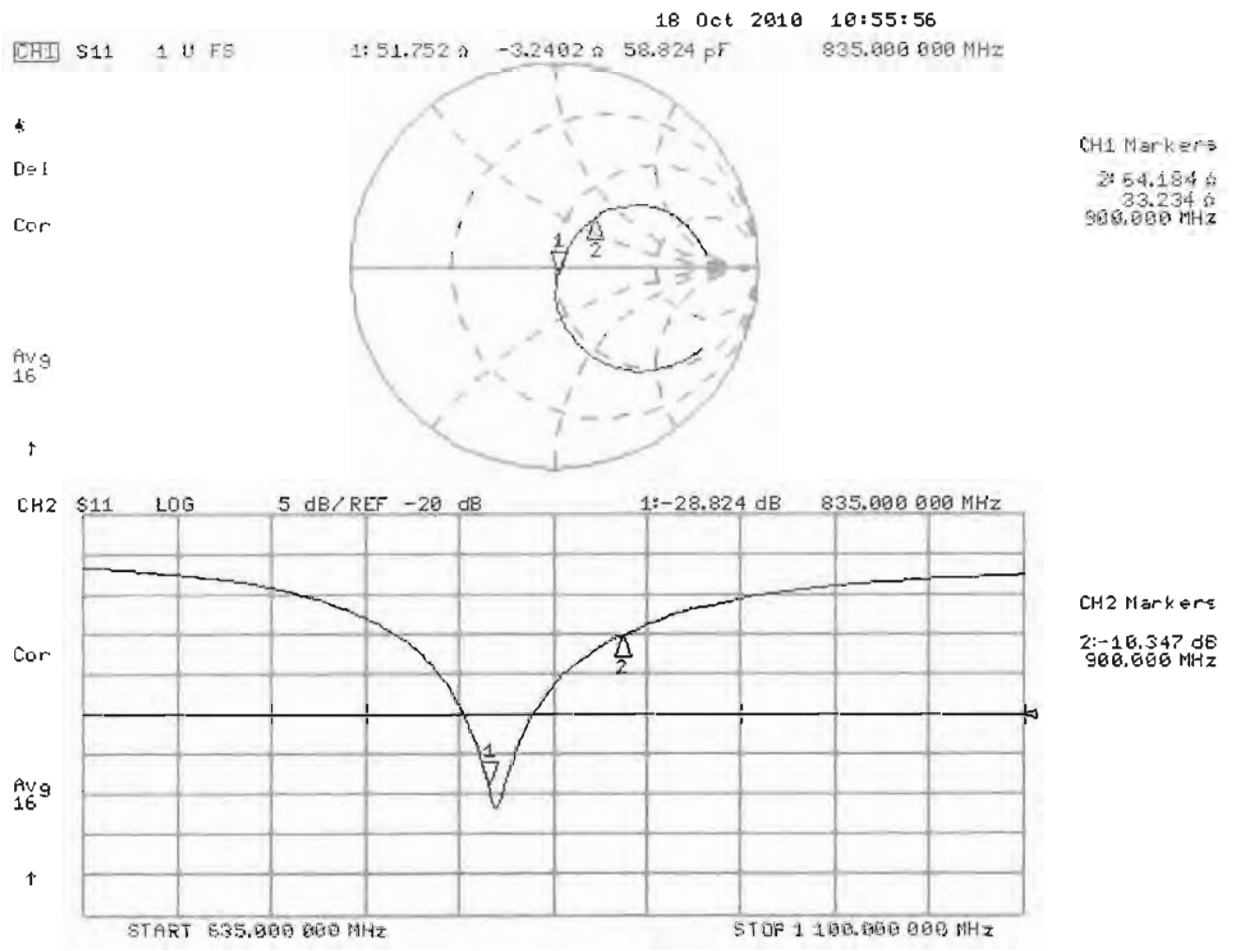

DASY5 Validation Report for Body

Date/Time: 19.10.2010 11:59:09

Test Laboratory: SPEAG, Zurich, Switzerland

DUT: Dipole 835 MHz; Type: D835V2; Serial: D835V2 - SN:4d108

Communication System: CW; Frequency: 835 MHz; Duty Cycle: 1:1

Medium: MSL900

Medium parameters used: $f = 835$ MHz; $\sigma = 0.99$ mho/m; $\epsilon_r = 54.4$; $\rho = 1000$ kg/m³

Phantom section: Flat Section

Measurement Standard: DASY5 (IEEE/IEC/ANSI C63.19-2007)

DASY5 Configuration:

- Probe: ES3DV3 - SN3205; ConvF(5.86, 5.86, 5.86); Calibrated: 30.04.2010
- Sensor-Surface: 3mm (Mechanical Surface Detection)
- Electronics: DAE4 Sn601; Calibrated: 10.06.2010
- Phantom: Flat Phantom 4.9L; Type: QD000P49AA; Serial: 1001
- Measurement SW: DASY52, V52.2 Build 0, Version 52.2.0 (163)
- Postprocessing SW: SEMCAD X, V14.2 Build 2, Version 14.2.2 (1685)

Pin=250 mW /d=15mm, dist=3.0mm (ES-Probe)/Zoom Scan (7x7x7) /Cube 0: Measurement grid: dx=5mm, dy=5mm, dz=5mm

Reference Value = 56.4 V/m; Power Drift = 0.0047 dB

Peak SAR (extrapolated) = 3.73 W/kg

SAR(1 g) = 2.53 mW/g; SAR(10 g) = 1.65 mW/g

Maximum value of SAR (measured) = 2.94 mW/g

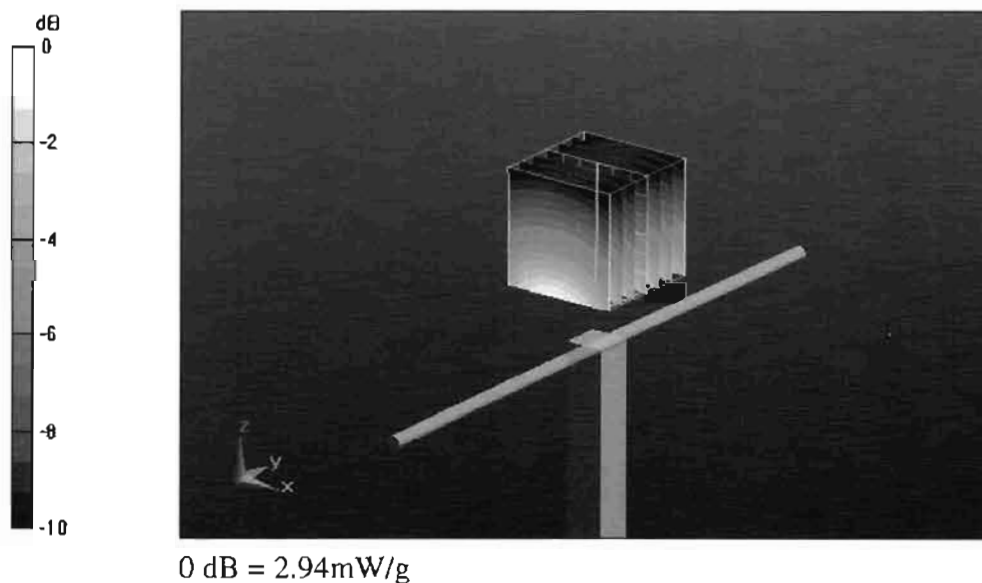

Impedance Measurement Plot for Body TSL

19 Oct 2010 09:56:43
CH1 S11 1 U FS 1: 48.027 Ω -4.3809 Ω 43.509 pF 835.000 000 MHz

*
De l

Cor

avg
16

↑

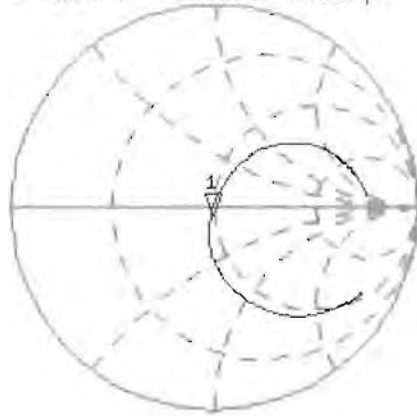

CH2 S11 LOG 5 dB/REF -20 dB 1:-26.208 dB 835.000 000 MHz

Cor

avg
16

↑

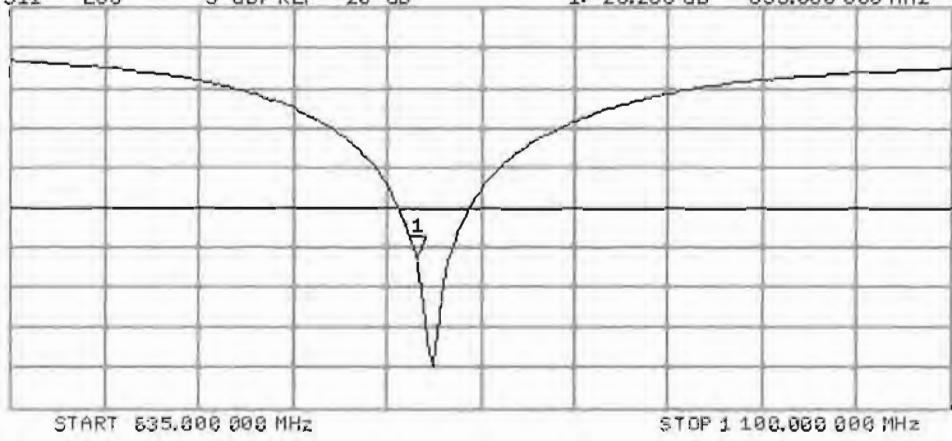

**Calibration Laboratory of
Schmid & Partner
Engineering AG**
Zeughausstrasse 43, 8004 Zurich, Switzerland



S Schweizerischer Kalibrierdienst
C Service suisse d'étalonnage
S Servizio svizzero di taratura
S Swiss Calibration Service

Accredited by the Swiss Accreditation Service (SAS)
The Swiss Accreditation Service is one of the signatories to the EA
Multilateral Agreement for the recognition of calibration certificates

Accreditation No.: **SCS 108**

Client **Northwest EMC**

Certificate No: **D1900V2-5d131_Nov10**

CALIBRATION CERTIFICATE

Object **D1900V2 - SN: 5d131**

Calibration procedure(s) **QA CAL-05.v7
Calibration procedure for dipole validation kits**

Calibration date: **November 24, 2010**

This calibration certificate documents the traceability to national standards, which realize the physical units of measurements (SI).
The measurements and the uncertainties with confidence probability are given on the following pages and are part of the certificate.

All calibrations have been conducted in the closed laboratory facility: environment temperature (22 ± 3)°C and humidity < 70%.

Calibration Equipment used (M&TE critical for calibration)

Primary Standards	ID #	Cal Date (Certificate No.)	Scheduled Calibration
Power meter EPM-442A	GB37480704	06-Oct-10 (No. 217-01266)	Oct-11
Power sensor HP 8481A	US37292783	06-Oct-10 (No. 217-01266)	Oct-11
Reference 20 dB Attenuator	SN: 5086 (20g)	30-Mar-10 (No. 217-01158)	Mar-11
Type-N mismatch combination	SN: 5047.2 / 06327	30-Mar-10 (No. 217-01162)	Mar-11
Reference Probe ES3DV3	SN: 3205	30-Apr-10 (No. ES3-3205_Apr10)	Apr-11
DAE4	SN: 601	10-Jun-10 (No. DAE4-601_Jun10)	Jun-11
Secondary Standards	ID #	Check Date (in house)	Scheduled Check
Power sensor HP 8481A	MY41092317	18-Oct-02 (in house check Oct-09)	In house check: Oct-11
RF generator R&S SMT-06	100005	4-Aug-99 (in house check Oct-09)	In house check: Oct-11
Network Analyzer HP 8753E	US37390585 S4206	18-Oct-01 (in house check Oct-10)	In house check: Oct-11

Calibrated by: **Name: Claudio Leubler, Function: Laboratory Technician**

[Signature]

Approved by: **Name: Katja Pokovic, Function: Technical Manager**

[Signature]

Issued: November 25, 2010



Accredited by the Swiss Accreditation Service (SAS)
The Swiss Accreditation Service is one of the signatories to the EA
Multilateral Agreement for the recognition of calibration certificates

Accreditation No.: **SCS 108**

Glossary:

TSL	tissue simulating liquid
ConvF	sensitivity in TSL / NORM x,y,z
N/A	not applicable or not measured

Calibration is Performed According to the Following Standards:

- IEEE Std 1528-2003, "IEEE Recommended Practice for Determining the Peak Spatial-Averaged Specific Absorption Rate (SAR) in the Human Head from Wireless Communications Devices: Measurement Techniques", December 2003
- IEC 62209-1, "Procedure to measure the Specific Absorption Rate (SAR) for hand-held devices used in close proximity to the ear (frequency range of 300 MHz to 3 GHz)", February 2005
- Federal Communications Commission Office of Engineering & Technology (FCC OET), "Evaluating Compliance with FCC Guidelines for Human Exposure to Radiofrequency Electromagnetic Fields; Additional Information for Evaluating Compliance of Mobile and Portable Devices with FCC Limits for Human Exposure to Radiofrequency Emissions", Supplement C (Edition 01-01) to Bulletin 65

Additional Documentation:

- DASY4/5 System Handbook

Methods Applied and Interpretation of Parameters:

- Measurement Conditions:** Further details are available from the Validation Report at the end of the certificate. All figures stated in the certificate are valid at the frequency indicated.
- Antenna Parameters with TSL:** The dipole is mounted with the spacer to position its feed point exactly below the center marking of the flat phantom section, with the arms oriented parallel to the body axis.
- Feed Point Impedance and Return Loss:** These parameters are measured with the dipole positioned under the liquid filled phantom. The impedance stated is transformed from the measurement at the SMA connector to the feed point. The Return Loss ensures low reflected power. No uncertainty required.
- Electrical Delay:** One-way delay between the SMA connector and the antenna feed point. No uncertainty required.
- SAR measured:** SAR measured at the stated antenna input power.
- SAR normalized:** SAR as measured, normalized to an input power of 1 W at the antenna connector.
- SAR for nominal TSL parameters:** The measured TSL parameters are used to calculate the nominal SAR result.

Measurement Conditions

DASY system configuration, as far as not given on page 1.

DASY Version	DASY5	V52.2
Extrapolation	Advanced Extrapolation	
Phantom	Modular Flat Phantom V5.0	
Distance Dipole Center - TSL	10 mm	with Spacer
Zoom Scan Resolution	dx, dy, dz = 5 mm	
Frequency	1900 MHz \pm 1 MHz	

Head TSL parameters

The following parameters and calculations were applied.

	Temperature	Permittivity	Conductivity
Nominal Head TSL parameters	22.0 °C	40.0	1.40 mho/m
Measured Head TSL parameters	(22.0 \pm 0.2) °C	39.3 \pm 6 %	1.40 mho/m \pm 6 %
Head TSL temperature during test	(22.0 \pm 0.2) °C	----	----

SAR result with Head TSL

SAR averaged over 1 cm ³ (1 g) of Head TSL	Condition	
SAR measured	250 mW input power	10.1 mW / g
SAR normalized	normalized to 1W	40.4 mW / g
SAR for nominal Head TSL parameters	normalized to 1W	40.2 mW / g \pm 17.0 % (k=2)

SAR averaged over 10 cm ³ (10 g) of Head TSL	condition	
SAR measured	250 mW input power	5.23 mW / g
SAR normalized	normalized to 1W	20.9 mW / g
SAR for nominal Head TSL parameters	normalized to 1W	20.9 mW / g \pm 16.5 % (k=2)

Body TSL parameters

The following parameters and calculations were applied.

	Temperature	Permittivity	Conductivity
Nominal Body TSL parameters	22.0 °C	53.3	1.52 mho/m
Measured Body TSL parameters	(22.0 ± 0.2) °C	52.8 ± 6 %	1.52 mho/m ± 6 %
Body TSL temperature during test	(22.0 ± 0.2) °C	----	----

SAR result with Body TSL

SAR averaged over 1 cm ³ (1 g) of Body TSL	Condition	
SAR measured	250 mW input power	10.0 mW / g
SAR normalized	normalized to 1W	40.0 mW / g
SAR for nominal Body TSL parameters	normalized to 1W	39.9 mW / g ± 17.0 % (k=2)

SAR averaged over 10 cm ³ (10 g) of Body TSL	condition	
SAR measured	250 mW input power	5.25 mW / g
SAR normalized	normalized to 1W	21.0 mW / g
SAR for nominal Body TSL parameters	normalized to 1W	21.0 mW / g ± 16.5 % (k=2)

Appendix

Antenna Parameters with Head TSL

Impedance, transformed to feed point	$52.7 \Omega + 6.5 j\Omega$
Return Loss	- 23.3 dB

Antenna Parameters with Body TSL

Impedance, transformed to feed point	$48.1 \Omega + 6.9 j\Omega$
Return Loss	- 22.8 dB

General Antenna Parameters and Design

Electrical Delay (one direction)	1.206 ns
----------------------------------	----------

After long term use with 100W radiated power, only a slight warming of the dipole near the feedpoint can be measured.

The dipole is made of standard semirigid coaxial cable. The center conductor of the feeding line is directly connected to the second arm of the dipole. The antenna is therefore short-circuited for DC-signals.

No excessive force must be applied to the dipole arms, because they might bend or the soldered connections near the feedpoint may be damaged.

Additional EUT Data

Manufactured by	SPEAG
Manufactured on	April 14, 2010

DASY5 Validation Report for Head TSL

Date/Time: 10.11.2010 16:31:30

Test Laboratory: SPEAG, Zurich, Switzerland

DUT: Dipole 1900 MHz; Type: D1900V2; Serial: D1900V2 - SN: 5d131

Communication System: CW; Frequency: 1900 MHz; Duty Cycle: 1:1

Medium: HSL U12 BB

Medium parameters used: $f = 1900$ MHz; $\sigma = 1.4$ mho/m; $\epsilon_r = 39.3$; $\rho = 1000$ kg/m³

Phantom section: Flat Section

Measurement Standard: DASY5 (IEEE/IEC/ANSI C63.19-2007)

DASY5 Configuration:

- Probe: ES3DV3 - SN3205; ConvF(5.09, 5.09, 5.09); Calibrated: 30.04.2010
- Sensor-Surface: 3mm (Mechanical Surface Detection)
- Electronics: DAE4 Sn601; Calibrated: 10.06.2010
- Phantom: Flat Phantom 5.0 (front); Type: QD000P50AA; Serial: 1001
- Measurement SW: DASY52, V52.2 Build 0, Version 52.2.0 (163)
- Postprocessing SW: SEMCAD X, V14.2 Build 2, Version 14.2.2 (1685)

Head/d=10mm, Pin=250 mW, dist=3.0mm (ES-Probe)/Zoom Scan (7x7x7) (7x7x7)/Cube 0:

Measurement grid: dx=5mm, dy=5mm, dz=5mm

Reference Value = 95.1 V/m; Power Drift = 0.064 dB

Peak SAR (extrapolated) = 18.4 W/kg

SAR(1 g) = 10.1 mW/g; SAR(10 g) = 5.23 mW/g

Maximum value of SAR (measured) = 12.6 mW/g

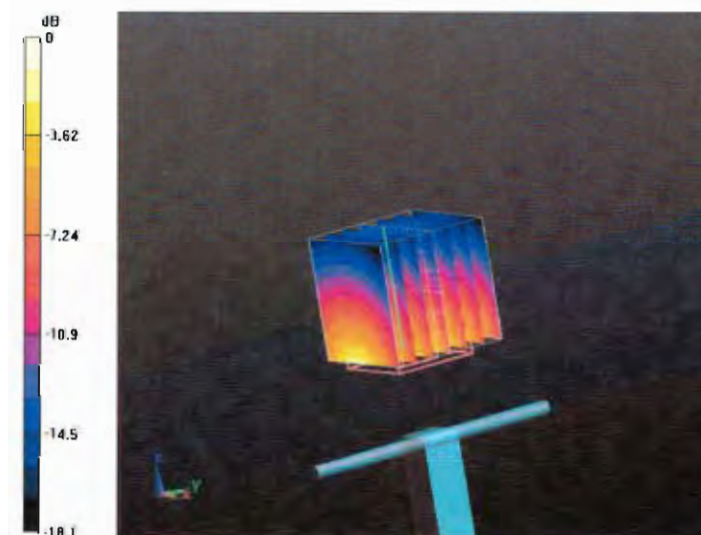

0 dB = 12.6mW/g

Impedance Measurement Plot for Head TSL

10 Nov 2010 13:03:53

CH1 S11 1 U FS

1: 52.686 Ω 6.4824 Ω 543.01 μH

1 900,000 000 MHz

+

Del

CA

Avg 16

T

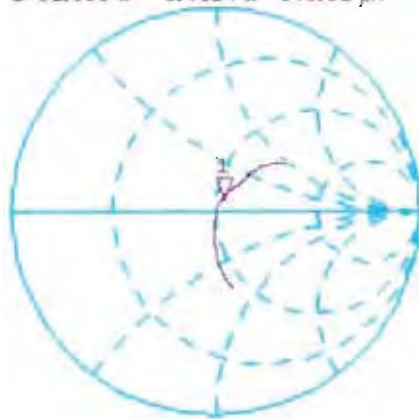

CH2 S11 LOG 5 dB/REF -20 dB 1: -23.325 dB 1 900,000 000 MHz

CA

Avg 16

T

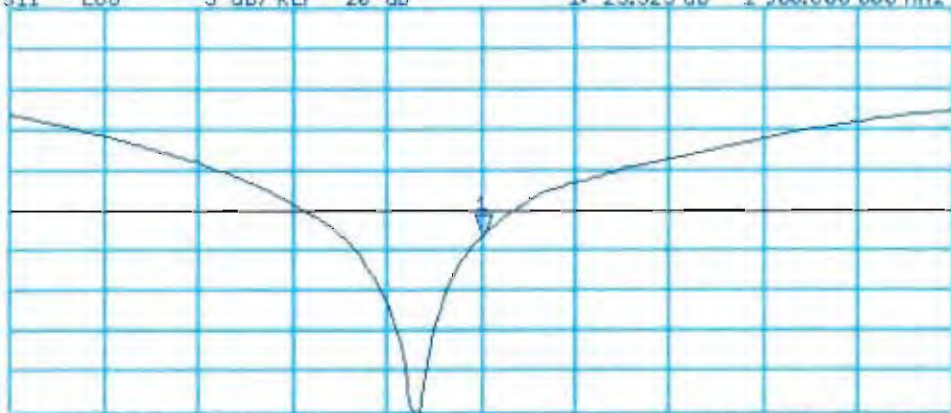

START 1 700,000 000 MHz

STOP 2 100,000 000 MHz

DASY5 Validation Report for Body

Date/Time: 24.11.2010 12:48:29

Test Laboratory: SPEAG, Zurich, Switzerland

DUT: Dipole 1900 MHz; Type: D1900V2; Serial: D1900V2 - SN:5d131

Communication System: CW; Frequency: 1900 MHz; Duty Cycle: 1:1

Medium: MSL U12 BB

Medium parameters used: $f = 1900$ MHz; $\sigma = 1.52$ mho/m; $\epsilon_r = 52.8$; $\rho = 1000$ kg/m³

Phantom section: Flat Section

Measurement Standard: DASY5 (IEEE/IEC/ANSI C63.19-2007)

DASY5 Configuration:

- Probe: ES3DV3 - SN3205; ConvF(4.59, 4.59, 4.59); Calibrated: 30.04.2010
- Sensor-Surface: 3mm (Mechanical Surface Detection)
- Electronics: DAE4 Sn601; Calibrated: 10.06.2010
- Phantom: Flat Phantom 5.0 (back); Type: QD000P50AA; Serial: 1002
- Measurement SW: DASY52, V52.2 Build 0, Version 52.2.0 (163)
- Postprocessing SW: SEMCAD X, V14.2 Build 2, Version 14.2.2 (1685)

Body/d=10mm, Pin=250 mW, dist=3.0mm (ES-Probe)/Zoom Scan (7x7x7) (7x7x7)/Cube 0:

Measurement grid: dx=5mm, dy=5mm, dz=5mm

Reference Value = 95.7 V/m; Power Drift = -0.00519 dB

Peak SAR (extrapolated) = 17.2 W/kg

SAR(1 g) = 10 mW/g; SAR(10 g) = 5.25 mW/g

Maximum value of SAR (measured) = 12.3 mW/g



0 dB = 12.3mW/g

Impedance Measurement Plot for Body TSL

24 Nov 2010 10:39:26

CH1 S11 1 V FS 3: 48.105 Ω 6.9102 Ω 578.83 pF 1 900.000 000 MHz

Del
Cor
Avg 16
↑

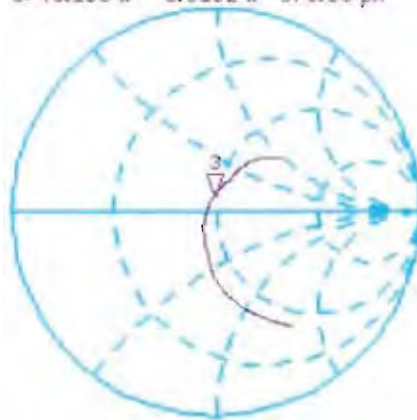

CH2 S11 LOG 5 dB/REF -20 dB 3:-22.750 dB 1 900.000 000 MHz

Cor
Avg 16
↑

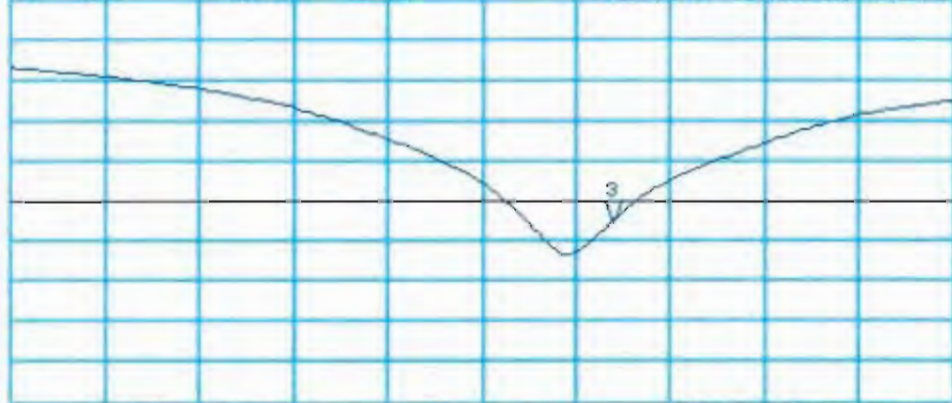

START 1 550.000 000 MHz STOP 2 100.000 000 MHz

**Calibration Laboratory of
Schmid & Partner
Engineering AG**
Zeughausstrasse 43, 8004 Zurich, Switzerland



S Schweizerischer Kalibrierdienst
C Service suisse d'étalonnage
S Servizio svizzero di taratura
S Swiss Calibration Service

Accredited by the Swiss Accreditation Service (SAS)
The Swiss Accreditation Service is one of the signatories to the EA
Multilateral Agreement for the recognition of calibration certificates

Accreditation No.: **SCS 108**

Client **Northwest EMC**

Certificate No: **D1750V2-1040_Nov10**

CALIBRATION CERTIFICATE

Object **D1750V2 - SN: 1040**

Calibration procedure(s) **QA CAL-05.v6
Calibration procedure for dipole validation kits**

Calibration date: **November 24, 2010**

This calibration certificate documents the traceability to national standards, which realize the physical units of measurements (SI).
The measurements and the uncertainties with confidence probability are given on the following pages and are part of the certificate.

All calibrations have been conducted in the closed laboratory facility: environment temperature (22 ± 3)°C and humidity < 70%.

Calibration Equipment used (M&TE critical for calibration)

Primary Standards	ID #	Cal Date (Certificate No.)	Scheduled Calibration
Power meter EPM-442A	GB37480704	06-Oct-10 (No. 217-01266)	Oct-11
Power sensor HP 8481A	US37292783	06-Oct-10 (No. 217-01266)	Oct-11
Reference 20 dB Attenuator	SN: 5086 (20g)	30-Mar-10 (No. 217-01158)	Mar-11
Type-N mismatch combination	SN: 5047.2 / 06327	30-Mar-10 (No. 217-01162)	Mar-11
Reference Probe ES3DV3	SN: 3205	30-Apr-10 (No. ES3-3205_Apr10)	Apr-11
DAE4	SN: 601	10-Jun-10 (No. DAE4-601_Jun10)	Jun-11
Secondary Standards	ID #	Check Date (in house)	Scheduled Check
Power sensor HP 8481A	MY41092317	18-Oct-02 (in house check Oct-09)	In house check: Oct-11
RF generator R&S SMT-06	100005	4-Aug-99 (in house check Oct-09)	In house check: Oct-11
Network Analyzer HP 8753E	US37390585 S4206	18-Oct-01 (in house check Oct-10)	In house check: Oct-11

Calibrated by: **Name** Claudio Leubler **Function** Laboratory Technician

Signature

Approved by: **Name** Katja Pokovic **Function** Technical Manager

Issued: November 25, 2010

This calibration certificate shall not be reproduced except in full without written approval of the laboratory.



Accredited by the Swiss Accreditation Service (SAS)
The Swiss Accreditation Service is one of the signatories to the EA
Multilateral Agreement for the recognition of calibration certificates

Accreditation No.: **SCS 108**

Glossary:

TSL	tissue simulating liquid
ConvF	sensitivity in TSL / NORM x,y,z
N/A	not applicable or not measured

Calibration is Performed According to the Following Standards:

- IEEE Std 1528-2003, "IEEE Recommended Practice for Determining the Peak Spatial-Averaged Specific Absorption Rate (SAR) in the Human Head from Wireless Communications Devices: Measurement Techniques", December 2003
- IEC 62209-1, "Procedure to measure the Specific Absorption Rate (SAR) for hand-held devices used in close proximity to the ear (frequency range of 300 MHz to 3 GHz)", February 2005
- Federal Communications Commission Office of Engineering & Technology (FCC OET), "Evaluating Compliance with FCC Guidelines for Human Exposure to Radiofrequency Electromagnetic Fields; Additional Information for Evaluating Compliance of Mobile and Portable Devices with FCC Limits for Human Exposure to Radiofrequency Emissions", Supplement C (Edition 01-01) to Bulletin 65

Additional Documentation:

- DASY4/5 System Handbook

Methods Applied and Interpretation of Parameters:

- Measurement Conditions:* Further details are available from the Validation Report at the end of the certificate. All figures stated in the certificate are valid at the frequency indicated.
- Antenna Parameters with TSL:* The dipole is mounted with the spacer to position its feed point exactly below the center marking of the flat phantom section, with the arms oriented parallel to the body axis.
- Feed Point Impedance and Return Loss:* These parameters are measured with the dipole positioned under the liquid filled phantom. The impedance stated is transformed from the measurement at the SMA connector to the feed point. The Return Loss ensures low reflected power. No uncertainty required.
- Electrical Delay:* One-way delay between the SMA connector and the antenna feed point. No uncertainty required.
- SAR measured:* SAR measured at the stated antenna input power.
- SAR normalized:* SAR as measured, normalized to an input power of 1 W at the antenna connector.
- SAR for nominal TSL parameters:* The measured TSL parameters are used to calculate the nominal SAR result.

Measurement Conditions

DASY system configuration, as far as not given on page 1.

DASY Version	DASY5	V52.2
Extrapolation	Advanced Extrapolation	
Phantom	Modular Flat Phantom V5.0	
Distance Dipole Center - TSL	10 mm	with Spacer
Zoom Scan Resolution	dx, dy, dz = 5 mm	
Frequency	1750 MHz ± 1 MHz	

Head TSL parameters

The following parameters and calculations were applied.

	Temperature	Permittivity	Conductivity
Nominal Head TSL parameters	22.0 °C	40.1	1.37 mho/m
Measured Head TSL parameters	(22.0 ± 0.2) °C	39.4 ± 6 %	1.32 mho/m ± 6 %
Head TSL temperature during test	(22.0 ± 0.2) °C	----	----

SAR result with Head TSL

SAR averaged over 1 cm³ (1 g) of Head TSL	Condition	
SAR measured	250 mW input power	9.13 mW / g
SAR normalized	normalized to 1W	36.5 mW / g
SAR for nominal Head TSL parameters	normalized to 1W	37.2 mW / g ± 17.0 % (k=2)

SAR averaged over 10 cm³ (10 g) of Head TSL	condition	
SAR measured	250 mW input power	4.85 mW / g
SAR normalized	normalized to 1W	19.4 mW / g
SAR for nominal Head TSL parameters	normalized to 1W	19.6 mW / g ± 16.5 % (k=2)

Body TSL parameters

The following parameters and calculations were applied.

	Temperature	Permittivity	Conductivity
Nominal Body TSL parameters	22.0 °C	53.4	1.49 mho/m
Measured Body TSL parameters	(22.0 ± 0.2) °C	52.9 ± 6 %	1.43 mho/m ± 6 %
Body TSL temperature during test	(21.7 ± 0.2) °C	----	----

SAR result with Body TSL

SAR averaged over 1 cm ³ (1 g) of Body TSL	condition	
SAR measured	250 mW input power	9.35 mW / g
SAR normalized	normalized to 1W	37.4 mW / g
SAR for nominal Body TSL parameters	normalized to 1W	38.2 mW / g ± 17.0 % (k=2)

SAR averaged over 10 cm ³ (10 g) of Body TSL	condition	
SAR measured	250 mW input power	5.03 mW / g
SAR normalized	normalized to 1W	20.1 mW / g
SAR for nominal Body TSL parameters	normalized to 1W	20.3 mW / g ± 16.5 % (k=2)

Appendix

Antenna Parameters with Head TSL

Impedance, transformed to feed point	$50.3 \Omega + 0.8 j\Omega$
Return Loss	- 41.6 dB

Antenna Parameters with Body TSL

Impedance, transformed to feed point	$46.0 \Omega + 1.1 j\Omega$
Return Loss	- 27.2 dB

General Antenna Parameters and Design

Electrical Delay (one direction)	1.220 ns
----------------------------------	----------

After long term use with 100W radiated power, only a slight warming of the dipole near the feedpoint can be measured.

The dipole is made of standard semirigid coaxial cable. The center conductor of the feeding line is directly connected to the second arm of the dipole. The antenna is therefore short-circuited for DC-signals.

No excessive force must be applied to the dipole arms, because they might bend or the soldered connections near the feedpoint may be damaged.

Additional EUT Data

Manufactured by	SPEAG
Manufactured on	December 02, 2009

DASY5 Validation Report for Head

Date/Time: 10.11.2010 13:00:43

Test Laboratory: SPEAG, Zurich, Switzerland

DUT: Dipole 1750 MHz; Type: D1750V2; Serial: D1750V2 - SN:1040

Communication System: CW; Frequency: 1750 MHz; Duty Cycle: 1:1

Medium: HSL U12 BB

Medium parameters used: $f = 1750$ MHz; $\sigma = 1.32$ mho/m; $\epsilon_r = 39.4$; $\rho = 1000$ kg/m³

Phantom section: Flat Section

Measurement Standard: DASY5 (IEEE/IEC/ANSI C63.19-2007)

DASY5 Configuration:

- Probe: ES3DV3 - SN3205; ConvF(5.25, 5.25, 5.25); Calibrated: 30.04.2010
- Sensor-Surface: 3mm (Mechanical Surface Detection)
- Electronics: DAE4 Sn601; Calibrated: 10.06.2010
- Phantom: Flat Phantom 5.0 (front); Type: QD000P50AA; Serial: 1001
- Measurement SW: DASY52, V52.2 Build 0, Version 52.2.0 (163)
- Postprocessing SW: SEMCAD X, V14.2 Build 2, Version 14.2.2 (1685)

Head/d=10mm, Pin=250 mW, dist=3.0mm (ES-Probe)/Zoom Scan (7x7x7) (7x7x7)/Cube 0:

Measurement grid: dx=5mm, dy=5mm, dz=5mm

Reference Value = 93.8 V/m; Power Drift = 0.050 dB

Peak SAR (extrapolated) = 16.4 W/kg

SAR(1 g) = 9.13 mW/g; SAR(10 g) = 4.85 mW/g

Maximum value of SAR (measured) = 11.3 mW/g

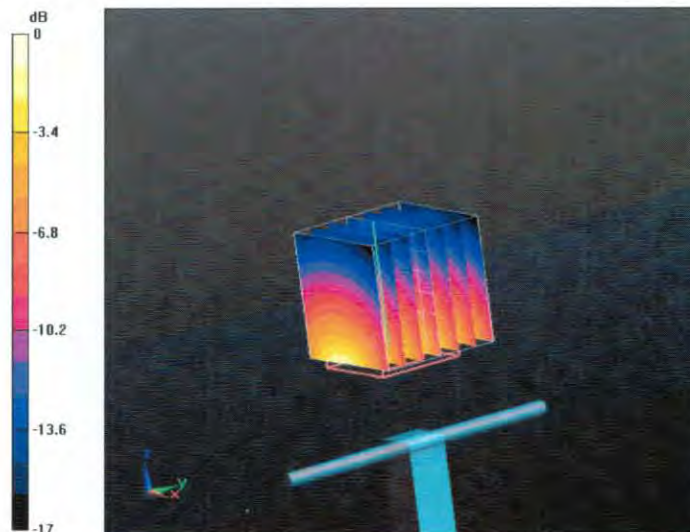

0 dB = 11.3mW/g

Impedance Measurement Plot for Head TSL

10 Nov 2010 11:36:58

CH1 S11 1 U FS 1: 50.342 Ω 0.7500 Ω 68.209 μH 1 750.000 000 MHz

*
De1
CA

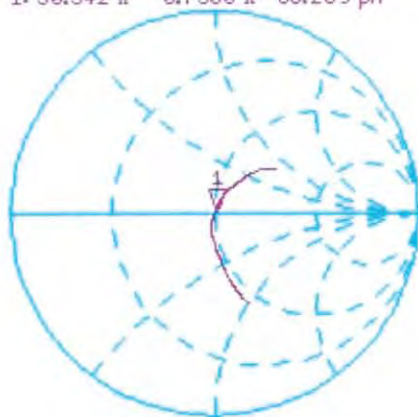

Avg
16
↑

CH2 S11 LOG 5 dB/REF -20 dB 1:-41.640 dB 1 750.000 000 MHz

CA
Avg
16
↑

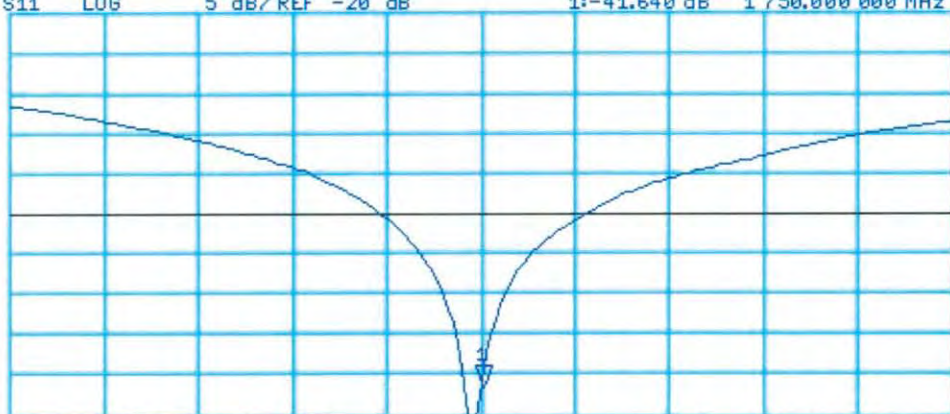

START 1 550.000 000 MHz

STOP 1 950.000 000 MHz

DASY5 Validation Report for Body TSL

Date/Time: 24.11.2010 10:28:00

Test Laboratory: SPEAG, Zurich, Switzerland

DUT: Dipole 1750 MHz; Type: D1750V2; Serial: D1750V2 - SN:1040

Communication System: CW; Frequency: 1750 MHz; Duty Cycle: 1:1

Medium: MSL U12 BB

Medium parameters used: $f = 1750$ MHz; $\sigma = 1.43$ mho/m; $\epsilon_r = 52.9$; $\rho = 1000$ kg/m³

Phantom section: Flat Section

Measurement Standard: DASY5 (IEEE/IEC/ANSI C63.19-2007)

DASY5 Configuration:

- Probe: ES3DV3 - SN3205; ConvF(4.8, 4.8, 4.8); Calibrated: 30.04.2010
- Sensor-Surface: 3mm (Mechanical Surface Detection)
- Electronics: DAE4 Sn601; Calibrated: 10.06.2010
- Phantom: Flat Phantom 5.0 (back); Type: QD000P50AA; Serial: 1002
- Measurement SW: DASY52, V52.2 Build 0, Version 52.2.0 (163)
- Postprocessing SW: SEMCAD X, V14.2 Build 2, Version 14.2.2 (1685)

Body/d=10mm, Pin=250 mW, dist=3.0mm (ES-Probe)/Zoom Scan (7x7x7) (7x7x7)/Cube 0:

Measurement grid: dx=5mm, dy=5mm, dz=5mm

Reference Value = 94.3 V/m; Power Drift = -0.015 dB

Peak SAR (extrapolated) = 16.1 W/kg

SAR(1 g) = 9.35 mW/g; SAR(10 g) = 5.03 mW/g

Maximum value of SAR (measured) = 11.7 mW/g

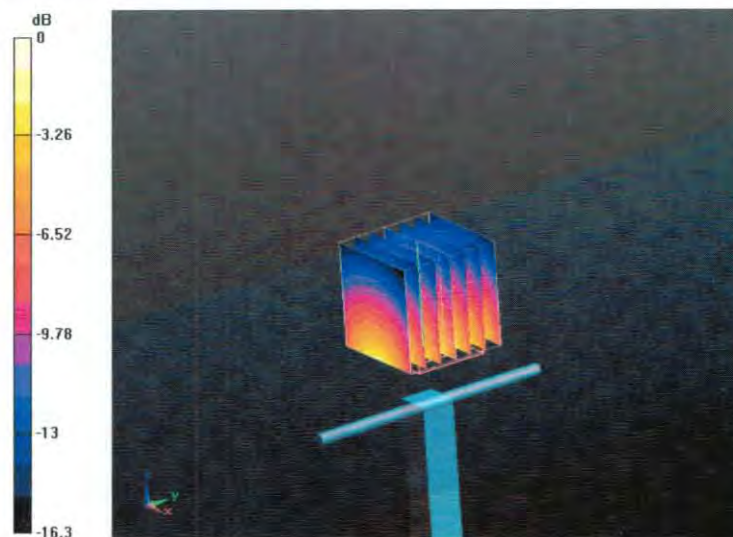

0 dB = 11.7mW/g

Impedance Measurement Plot for Body TSL

24 Nov 2010 10:21:58

CH1 S11 1 U FS 1: 45.982 Ω 1.0762 Ω 97.873 pF 1 750.000 000 MHz

*
Del
Cor

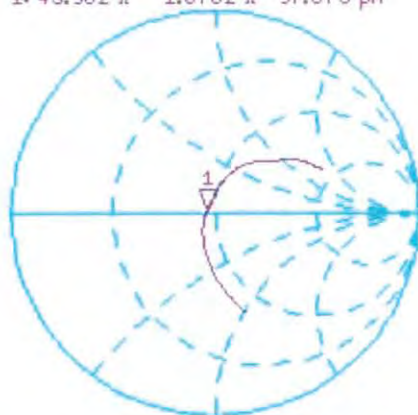

Avg
16

CH2 S11 LOG 5 dB/REF -20 dB 1: -27.237 dB 1 750.000 000 MHz

Cor

Avg
16

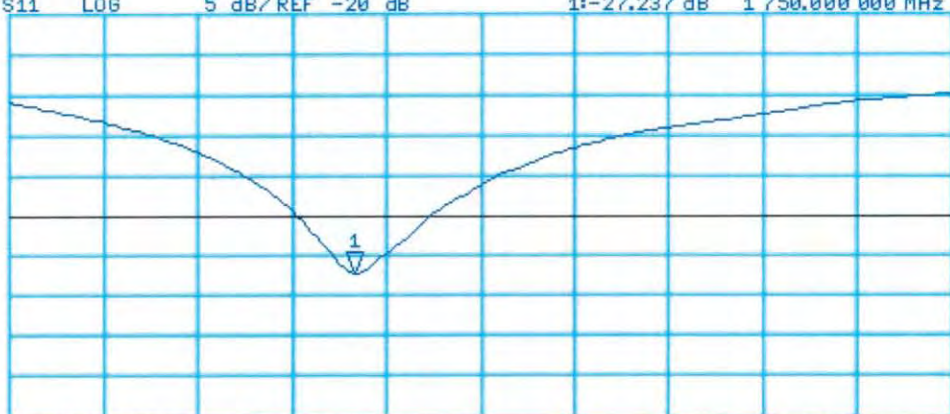

START 1 550.000 000 MHz

STOP 2 100.000 000 MHz