



**ANSI C63.19-2007  
HAC RF EMISSIONS TEST REPORT**

*For*

**Heavy-Duty Handheld PDA-Type Device W/ Dual Band GSM/WCDMA/HSDPA/HSUPA**

**MODEL: CN50**

**FCC ID: EHA-01CN50**

**IC: 1223A-01CN50**

**REPORT NUMBER: 09U12487-6**

**ISSUE DATE: April 23, 2009**

*Prepared for*

**INTERMEC TECHNOLOGIES CORPORATION  
6001 – 36TH AVENUE WEST  
EVERETT, WA 98203, USA**

*Prepared by*

**COMPLIANCE CERTIFICATION SERVICES  
47173 BENICIA STREET  
FREMONT, CA 94538, U.S.A.  
TEL: (510) 771-1000  
FAX: (510) 661-0888**



NVLAP LAB CODE 200065-0

Revision History

Rev.	Issue Date	Revisions	Revised By
--	April 23, 2009	Initial Issue	--

## TABLE OF CONTENTS

<b>1. ATTESTATION OF TEST RESULTS</b> .....	<b>4</b>
<b>2. TEST METHODOLOGY</b> .....	<b>5</b>
<b>3. FACILITIES AND ACCREDITATION</b> .....	<b>5</b>
<b>4. CALIBRATION AND UNCERTAINTY</b> .....	<b>5</b>
4.1. <i>MEASURING INSTRUMENT CALIBRATION</i> .....	5
4.2. <i>MEASUREMENT UNCERTAINTY</i> .....	6
<b>5. EQUIPMENT UNDER TEST</b> .....	<b>7</b>
<b>6. SYSTEM SPECIFICATIONS</b> .....	<b>8</b>
<b>7. SYSTEM VALIDATION</b> .....	<b>9</b>
7.1. <i>SYSTEM VALIDATION RESULTS</i> .....	10
<b>8. PROBE MODULATION FACTOR (PMF)</b> .....	<b>11</b>
8.1. <i>PMF RESULTS FOR GSM</i> .....	13
8.2. <i>PMF RESULTS FOR CDMA</i> .....	13
<b>9. HAC RF EMISSIONS TEST PROCEDURE</b> .....	<b>14</b>
<b>10. SUMMARY OF TEST RESULTS</b> .....	<b>16</b>
10.1. <i>CELLULAR BAND</i> .....	16
10.1.1. <i>E-FILED EMISSIONS</i> .....	16
10.1.2. <i>H-FILED EMISSIONS</i> .....	16
10.2. <i>PCS BAND</i> .....	17
10.2.1. <i>E-FILED EMISSIONS</i> .....	17
10.2.2. <i>H-FILED EMISSIONS FOR PCS BAND</i> .....	17
<b>11. ATTACHMENTS</b> .....	<b>18</b>
<b>12. TEST SETUP PHOTO</b> .....	<b>19</b>

# 1. ATTESTATION OF TEST RESULTS

<b>COMPANY NAME:</b>	INTERMEC TECHNOLOGIES CORPORATION 6001 – 36TH AVENUE WEST EVERETT, WA 98203, USA	
<b>EUT DESCRIPTION:</b>	Heavy-Duty Handheld PDA-Type Device W/ Dual Band GSM/WCDMA/HSDPA/HSUPA	
<b>MODEL NUMBER:</b>	CN50	
<b>DEVICE CATEGORY:</b>	Portable	
<b>EXPOSURE CATEGORY:</b>	General Population/Uncontrolled Exposure	
<b>DATE TESTED:</b>	April 20 - 22, 2009	
<b>MAX E-FIELD EMISSIONS:</b>	Part 22 - Cellular band:	133.4 V/m (M4)
	Part 24 - PCS band:	57.3 V/m (M3)
	Part 27 - UMTS Band IV	15.7 V/m (M4)
<b>MAX H-FIELD EMISSIONS:</b>	Part 22 - Cellular band:	0.286 A/m (M4)
	Part 24 - PCS band:	0.161 A/m (M3)
	Part 27 - UMTS Band IV	0.042 A/m (M4)

**Hearing Aid Near-Field Category: M3**

### APPLICABLE STANDARDS:

STANDARD	TEST RESULTS
ANSI C63.19-2007	Pass

Compliance Certification Services, Inc. (CCS) tested the above equipment in accordance with the requirements set forth in the above standards. All indications of Pass/Fail in this report are opinions expressed by CCS based on interpretations and/or observations of test results. The test results show that the equipment tested is capable of demonstrating compliance with the requirements as documented in this report.

Note: The results documented in this report apply only to the tested sample, under the conditions and modes of operation as described herein. This document may not be altered or revised in any way unless done so by CCS and all revisions are duly noted in the revisions section. Any alteration of this document not carried out by CCS will constitute fraud and shall nullify the document. No part of this report may be used to claim product certification, approval, or endorsement by NVLAP, NIST, or any government agency.

Approved & Released For CCS By:

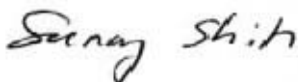

SUNNY SHIH  
ENGINEERING SUPERVISOR  
COMPLIANCE CERTIFICATION SERVICES

## 2. TEST METHODOLOGY

The tests documented in this report were performed in accordance with ANSI C63.19 Methods of Measurement of Compatibility between Wireless Communications Devices and Hearing Aids and FCC KDB 285076 D01 HAC Guidance v01.

## 3. FACILITIES AND ACCREDITATION

The test sites and measurement facilities used to collect data are located at 47173 Benicia Street, Fremont, California, USA.

CCS is accredited by NVLAP, Laboratory Code 200065-0. The full scope of accreditation can be viewed at <http://ts.nist.gov/Standards/scopes/2000650.htm>.

## 4. CALIBRATION AND UNCERTAINTY

### 4.1. MEASURING INSTRUMENT CALIBRATION

The measuring equipment utilized to perform the tests documented in this report has been calibrated in accordance with the manufacturer's recommendations, and is traceable to recognized national standards.

<u>Name of Equipment</u>	<u>Manufacturer</u>	<u>Type/Model</u>	<u>Serial Number</u>	<u>Cal. Due date</u>
Robot - Six Axes	Stäubli	RX90BL	N/A	N/A
Robot Remote Control	Stäubli	CS7MB	3403-91535	N/A
DASY4 Measurement Server	SPEAG	SEUMS001BA	1041	N/A
Probe Alignment Unit	SPEAG	LB (V2)	261	N/A
Data Acquisition Electronics	SPEAG	DAE3	427	10/20/09
E-Field Probe	SPEAG	ER3DV6	2339	2/9/10
H-Field Probe	SPEAG	H3DV6	6157	2/10/10
Calibration Dipole	SPEAG	CD1880V3	1010	2/11/10
Calibration Dipole	SPEAG	CD835V3	1014	2/11/10
Power Meter	Giga-Tronics	8651A	8651404	1/11/10
Power Sensor	Giga-Tronics	80701A	1834588	4/11/10
Amplifier	Mini-Circuits	ZHL-42W	D072701-5	N/A
Radio Communication Tester	R & S	CMU 200	106291	5/16/09

## 4.2. MEASUREMENT UNCERTAINTY

HAC Uncertainty Budget According to ANSI PC63.19							
Error Description	Uncertainty value (±%)	Probe Dist.	Div.	(Ci) E	(Ci) H	Std. Unc.(±%)	
						E	H
<b>Measurement System</b>							
Probe Calibration	5.10	N	1	1	1	5.1	5.1
Axial Isotropy	4.70	R	1.732	1	1	2.7	2.7
Sensor Displacement	16.50	R	1.732	1	0.145	9.5	1.4
Boundary Effects	2.40	R	1.732	1	1	1.4	1.4
Linearity	4.70	R	1.732	1	1	2.7	2.7
Scaling to Peak Envelope Power	2.00	R	1.732	1	1	1.2	1.2
System Detection Limit	1.00	R	1.732	1	1	0.6	0.6
Readout Electronics	0.30	N	1	1	1	0.3	0.3
Response Time	0.80	R	1.732	1	1	0.5	0.5
Integration Time	2.60	R	1.732	1	1	1.5	1.5
RF Ambient Conditions	3.00	R	1.732	1	1	1.7	1.7
RF Reflections	12.00	R	1.732	1	1	6.9	6.9
Probe Positioner	1.20	R	1.732	1	0.67	0.7	0.5
Probe Positioning	4.70	R	1.732	1	0.67	2.7	1.8
Extrapolation and Interpolation	1.00	R	1.732	1	1	0.6	0.6
<b>Test sample Related</b>							
Test Positioning Vertical	4.70	R	1.732	1	0.67	2.7	1.8
Test Positioning Lateral	1.00	R	1.732	1	1	0.6	0.6
Device Holder and Phantom	2.40	R	1.732	1	1	1.4	1.4
Power Drift	5.00	R	1.732	1	1	2.9	2.9
<b>Phantom and Setup Related</b>							
Phantom Thickness	2.40	R	1.732	1	0.67	1.4	0.9
Combined Std. Uncertainty						14.7	10.9
<b>Expanded Std. Uncertainty on Power</b>						<b>29.4</b>	<b>21.8</b>
<b>Expanded Std. Uncertainty on Field</b>						<b>14.7</b>	<b>10.9</b>
Notes for table							
1. N - Nomal							
2. R - Rectangular							
3. Div. - Divisor used to obtain standard uncertainty							
4. Ci - is te sensitivy coefficient							

## 5. EQUIPMENT UNDER TEST

Heavy-Duty Handheld PDA-Type Device W/ Dual Band GSM/WCDMA/HSDPA/HSUPA

Normal Operation:

- Held to head
- Worn on body

Antenna(s):

Internal

## 6. SYSTEM SPECIFICATIONS

E-field and H-field measurements are performed using the DASY4 automated dosimetric assessment system. The DASY4 is made by Schmid & Partner Engineering AG (SPEAG) in Zurich, Switzerland.

The DASY4 HAC Extension consists of the following parts:

### Test Arch Phantom

The specially designed Test Arch allows high precision positioning of both the device and any of the validation dipoles.

### ER3DV6 Isotropic E-Field Probe

Construction:	One dipole parallel, two dipoles normal to probe axis Built-in shielding against static charges PEEK enclosure material (resistant to organic solvents, e.g., glycoether)
Calibration:	In air from 100 MHz to 3.0 GHz (absolute accuracy $\pm 6.0\%$ , $k=2$ )
Frequency:	100 MHz to > 6 GHz; Linearity: $\pm 0.2$ dB (100 MHz to 3 GHz)
Directivity:	$\pm 0.2$ dB in air (rotation around probe axis) $\pm 0.4$ dB in air (rotation normal to probe axis)
Dynamic Range:	2 V/m to > 1000 V/m; Linearity: $\pm 0.2$ dB
Dimensions:	Overall length: 330 mm (Tip: 16 mm) Tip diameter: 8 mm (Body: 12 mm) Distance from probe tip to dipole centers: 2.5 mm The closest part of the sensor element is 1.1 mm closer to the tip
Application:	General near-field measurements up to 6 GHz Field component measurements

### H3DV6 3-Dimensional H-Field Probe

Construction:	Three concentric loop sensors with 3.8 mm loop diameters resistively loaded detector diodes for linear response Built-in shielding against static charges PEEK enclosure material (resistant to organic solvents, e.g., glycoether)
Frequency:	200 MHz to 3 GHz (absolute accuracy $\pm 6.0\%$ , $k=2$ ); Output linearized
Directivity:	$\pm 0.25$ dB (spherical isotropy error)
Dynamic Range:	10 mA/m to 2 A/m at 1 GHz
E-Field Interference:	< 10% at 3 GHz (for plane wave)
Dimensions:	Overall length: 330 mm (Tip: 40 mm) Tip diameter: 6 mm (Body: 12 mm) Distance from probe tip to dipole centers: 3 mm The closest part of the sensor element is 1.9 mm closer to the tip
Application:	General magnetic near-field measurements up to 3 GHz Field component measurements Surface current measurements Measurements in air or liquids Low interaction with the measured field



## 7. SYSTEM VALIDATION

The test setup was validated when first configured and verified periodically thereafter to ensure proper function. The procedure provided in this section is a validation procedure using dipole antennas for which the field levels were computed by numeric modeling.

### Procedure

Place a dipole antenna meeting the requirements given in ANSI-PC63.19 2007 in the normally occupied by the WD.

The dipole antenna serves as a known source for an electrical and magnetic output. Position the E-field and H-field probes so that:

- The probes and their cables are parallel to the coaxial feed of the dipole antenna
- The probe cables and the coaxial feed of the dipole antenna approach the measurement area from opposite directions;
- The center point of the probe element(s) are 10 mm from the closest surface of the dipole elements.

Scan the length of the dipole with both E-field and H-field probes and record the maximum values for each. Compare the readings to expected values.

**Setup diagram**

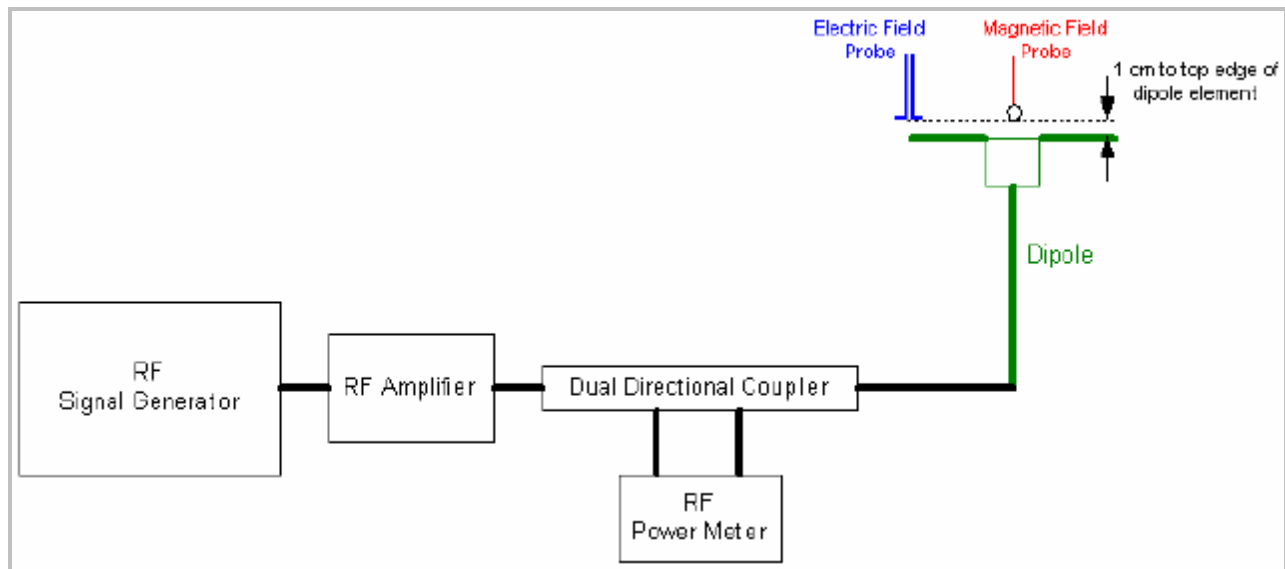

## 7.1. SYSTEM VALIDATION RESULTS

E-Filed

Calibration Dipole	f (MHz)	Input Power (mW)	Max. measured from		Average max. above arm (V/m)	E-field Target Values (V/m) (From SPEAG)	Deviation <sup>1)</sup> (%)
			above high end (V/m)	above low end (V/m)			
CD835V3 SN 1014	1880	100	127.1	127.70	127.40	137.2	-7.14
CD835V3 SN 1014	835	100	172.2	167.2	169.70	162.5	4.43

H-field

Signal Type	f (MHz)	Input Power (mW)	Measured H-field (A/m)	H-field Target Values (A/m)	Deviation <sup>1)</sup> (%)
CD835V3 SN 1014	1880	100	0.445	0.467	-4.71
CD835V3 SN 1014	835	100	0.465	0.450	3.33

Notes:

- 1) Delta (Deviation) % = 100 \* (Measured value minus Target value) divided by the Target value. Deltas within ±25% are acceptable, of which 12% is deviation and 13% is measurement uncertainty.
- 2) The maximum E-field or H-field were evaluated and compared to the target values provided by SPEAG in the calibration certificate of specific dipoles.
- 3) Please refer to the attachment for detailed measurement data and plots.

## 8. PROBE MODULATION FACTOR (PMF)

### Purpose

The HAC Standard requires measurement of the peak envelope E- and H-fields of the wireless device (WD). Para. 4.1.2.1, and C.3.1 of the standard describes the Probe Modulation Response Factor that shall be applied to convert the probe reading to Peak Envelope Field.

### Definitions

The Probe Modulation Factor (PMF) is defined as the ratio of the field readings for a CW and a modulated signal with the equivalent Field Envelope Peak as defined in the Standard (Chapter C.3.1).

### Evaluation Procedure for Unknown PMF (DASY4 Application note, Section 28.8)

The proposed measurement setup corresponds to the procedure as required in the Standard, Chapter C.3.1.

1. Install a calibration dipole for the appropriate frequency band under the Test Arch Phantom and select the proper phantom section according to the probe type installed (E- or H-field). Move the probe to the field reference point. (Do not move the probe between the subsequent CW and modulated measurements.)
2. Install the field probe in the setup.
3. The modulated signal to the dipole must be monitored to record peak amplitude and compared to a CW signal with the same peak envelope level (e.g., with a directional coupler and a spectrum analyzer in zero span mode set to the operating frequency). To determine the peak envelope level of the modulated signal properly, the settings of a spectrum analyzer shall be as follows:
  - Resolution bandwidth  $\geq$  emission bandwidth
  - Video bandwidth  $\geq$  20kHz
  - Span: zero
  - Center Frequency: nominal center frequency of channel
  - Detection: RMS detection with averaging turned on
  - Trigger: Video or IF trigger, adjusted to give a stable display of the transmission
  - Sweep rate: Sufficiently rapid to permit the transmit pulse to be resolved accurately. The sweep shall be long enough to show a complete transmission. The sweep time may be set to allow a full transmission cycle, displaying the on and off time.
4. Define a DASY4 document and set the procedure properties (frequency, modulation frequency and crest factor) according to the measured signal. Define a multimeter job for the field reading.
5. Define a second procedure for the evaluation of the CW signal (frequency set as above, modulation frequency = 0, crest factor = 1) and a multimeter job.

**PMF Measurement Setup Diagram**

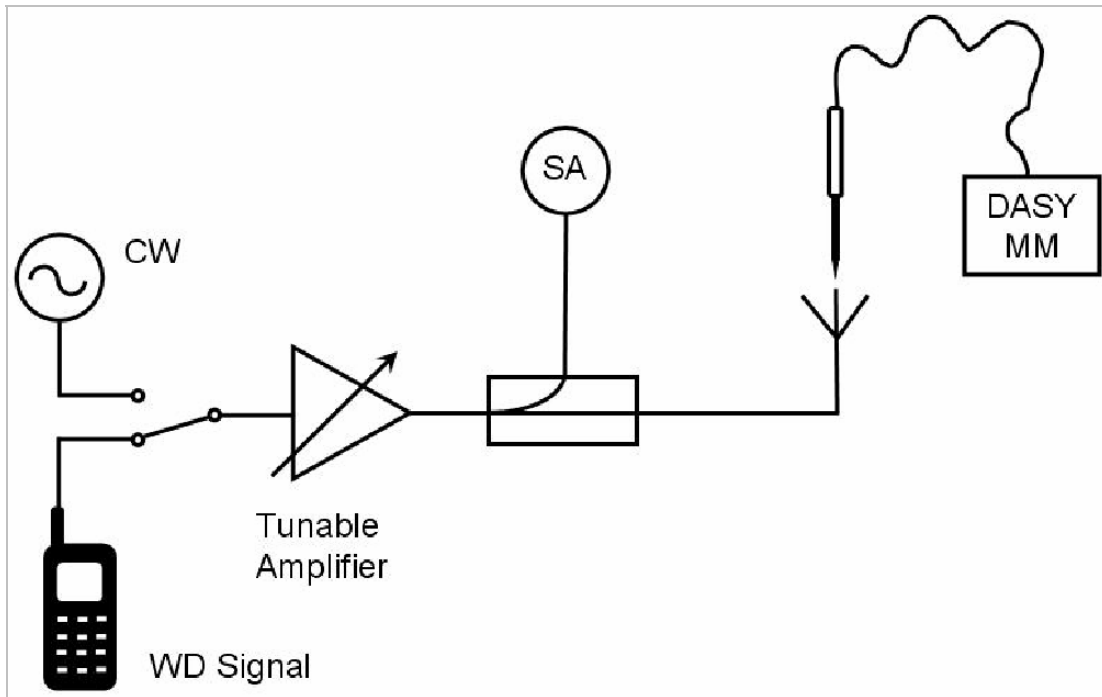

**The HAC measurement procedure is as follows:**

- a) Modulated signals (WD and 80% AM) measurement:
  - 1) Connect the modulated signal using the appropriate frequency via the cable to the dipole.
  - 2) The signal to the dipole must be monitored to record peak amplitude with a directional coupler and a spectrum analyzer.
  - 3) Run the multimeter job in the procedure with the corresponding modulation setting in continuous mode.
  - 4) Read the envelope peak on the monitor in order to adjust the CW signal later to the same level.
- b) CW signal measurement:
  - 1) Change the signal to CW at the same center frequency, without touching or moving the dipole and probe in the setup.
  - 2) Adjust the CW signal amplitude to the same peak level on the spectrum analyzer (keep the same bandwidth and attenuation for CW and modulated signals).
  - 3) Run the multimeter job in the CW procedure in continuous mode.
  - 4) Read the multimeter total field display and note it together with modulation type and frequency.
  - 5) Calculate the Probe Modulation Factor as the ratio between the CW multimeter field reading and the reading for the applicable modulation. I.e.,  $PMF = \frac{E_{cw}}{E_{mod}}$  and similar for H.

**8.1. PMF RESULTS FOR GSM**

Probe	Frequency (MHz)	Type of signal	E-field V/m	PMF
E-Field Probe	835	GSM	37.2	2.98
		CW	110.8	
	1880	GSM	29.0	2.75
		CW	79.8	
Probe	Frequency (MHz)	Type of signal	H-field A/m	PMF
H-Field Probe	835	GSM	0.128	2.85
		CW	0.365	
	1880	GSM	0.102	2.75
		CW	0.280	

**8.2. PMF RESULTS FOR CDMA**

Probe	Frequency (MHz)	Type of signal	E-field V/m	PMF
E-Field Probe	835	WCDMA	53.5	1.02
		CW	54.5	
	1880	WCDMA	50.0	0.92
		CW	46.0	
Probe	Frequency (MHz)	Type of signal	H-field A/m	PMF
H-Field Probe	835	WCDMA	0.239	0.97
		CW	0.232	
	1880	WCDMA	0.184	0.90
		CW	0.166	

## 9. HAC RF EMISSIONS TEST PROCEDURE

The following are step-by-step test procedures.

1. Confirm proper operation of the field probe, probe measurement system and other instrumentation and the positioning system.
2. Position the WD in its intended test position.
3. Configure the WD normal operation for maximum rated RF output power, at the desired channel and other operating parameters, (e.g. test mode) as intended for the test.
4. The center sub-grid shall be centered on the center of the WD output (acoustic or T-coil output), as appropriate. Locate the field probe at the initial test position in the 5 x 5 cm grid, which is contained in the measurement plane, see illustrated in Figure 5.
5. Record the reading.
6. Scan the entire 5 x 5 cm region in equally spaced increments and record the reading at each measurement point. The distance between measurement points shall be sufficient to assure the identification of the peak reading.
7. Identify the five contiguous sub-grids around the center sub-grid with the lowest maximum strength readings. Thus the 6 areas to be used to determine the WD's peak emissions are identified and outlined for the final manual scan. Please note that a maximum of five blocks can be excluded for both E- and H-field measurements for the WD output being measured. State another way, the center sub-grid and 3 other must be common to both the E- and H-field measurements.
8. Identify the highest field reading within the non-excluded sub-grids identified in step 7.
9. Convert the highest field reading within identified in step 8 to peak V/m or A/m, as appropriate.
10. Repeat steps 1-10 for both the E- and H-field measurements.
11. Compare this reading to the categories in ANSI-PC63.19 and record the resulting category. The lowest category number listed in ANSI-PC63.19 obtained in step 10 for either E or H field determines the M category for the audio coupling mode assessment. Record the WD category rating.

**Test flowchart Per ANSI-PC63.19 2007**

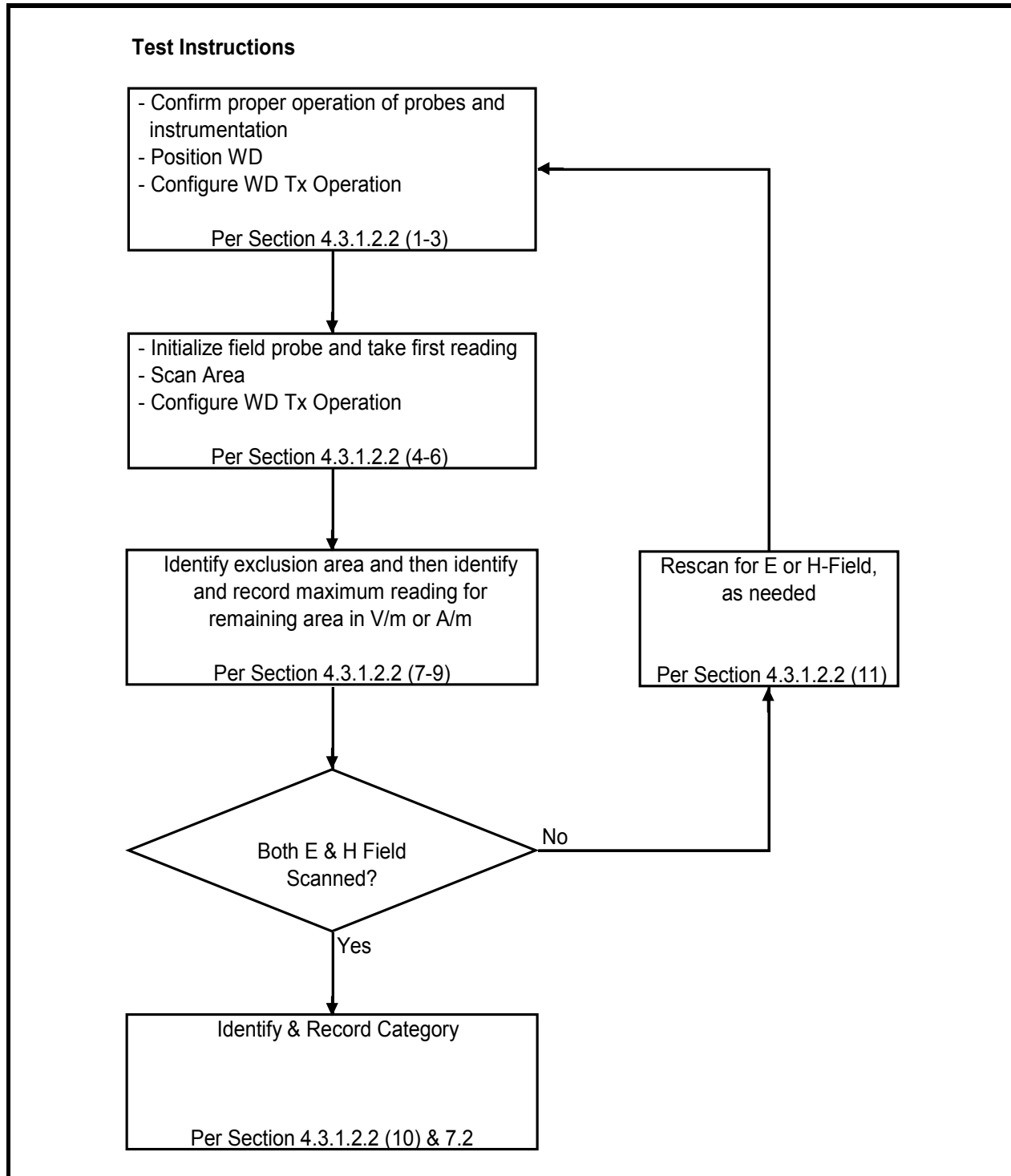

## 10. SUMMARY OF TEST RESULTS

Telephone near-field Categories in linear units

		Telephone RF Parameters			
		< 960 MHz		> 960 MHz	
Category	AWF	E-Field Emissions (V/m)	H-Field Emissions (A/m)	E-Field Emissions (V/m)	H-Field Emissions (A/m)
M3	0	199.5 to 354.8	0.60 to 1.07	63.1 to 112.2	0.19 to 0.34
	-5	149.6 to 266.1	0.45 to 0.80	47.3 to 84.1	0.14 to 0.25
M4	0	< 199.5	< 0.60	< 63.1	< 0.19
	-5	< 149.6	< 0.45	< 47.3	< 0.14

### 10.1. CELLULAR BAND

#### 10.1.1. E-FILED EMISSIONS

Operating Mode	Ch. No.	f (MHz)	PMF	Peak E-Field (V/m)	M-Rating
GSM850	128	824.2	2.98	117.4	M4
	190	836.6		133.4	M4
	251	848.8		123.0	M4
WCDMA (Band V)	4132	826.4	1.02	36.4	M4
	8182	836.4		34.1	M4
	5233	846.6		41.3	M4

#### 10.1.2. H-FILED EMISSIONS

Operating Mode	Ch. No.	f (MHz)	PMF	Peak H-Field (V/m)	M-Rating
GSM850	128	824.2	2.85	0.237	M4
	190	836.6		0.286	M4
	251	848.8		0.260	M4
WCDMA (Band V)	4132	826.4	0.97	0.078	M4
	8182	836.4		0.073	M4
	5233	846.6		0.085	M4



## 10.2. PCS BAND

### 10.2.1. E-FILED EMISSIONS

Operating Mode	Ch. No.	f (MHz)	PMF	Peak E-Field (V/m)	M-Rating
GSM1900	512	1850.2	2.75	57.30	M3
	661	1880.0		50.00	M3
	810	1909.8		46.70	M4
WCDMA (Band II)	9262	1852.4	0.92	22.10	M4
	9400	1880.0		23.90	M4
	9538	1907.6		21.20	M4
WCDMA (Band IV)	1312	1712.4	0.92	11.70	M4
	1412	1732.4		14.00	M4
	1513	1754.0		15.70	M4

### 10.2.2. H-FILED EMISSIONS FOR PCS BAND

Operating Mode	Ch. No.	f (MHz)	PMF	Peak H-Field (A/m)	M-Rating
GSM1900	512	1850.2	2.75	0.161	M3
	661	1880.0		0.145	M3
	810	1909.8		0.135	M4
WCDMA (Band II)	9262	1852.4	0.90	0.058	M4
	9400	1880.0		0.066	M4
	9538	1907.6		0.062	M4
WCDMA (Band IV)	1312	1712.4	0.90	0.032	M4
	1412	1732.4		0.039	M4
	1513	1754.0		0.042	M4

## 11. ATTACHMENTS

<u>No.</u>	<u>Contents</u>	<u>No. of page (s)</u>
1	System Validation Plots for CD1880V3 & CD835V3	8
2	E&H Filed Emissions Plots for GSM850	12
3	E&H Filed Emissions Plots for UMTS Band V	12
4	E&H Filed Emissions Plots for GSM1900	12
5	E&H Filed Emissions Plots for UMTS Band II	12
6	E&H Filed Emissions Plots for UMTS Band IV	12
7	Certificate of E-Field Probe - ER3DV6 SN 2339	9
8	Certificate of H-Field Probe - H3DV6 SN 6157	9
9	Certificate of Dipole CD1880V3 - SN 1010	6
a	Certificate of Dipole CD835V3 - SN 1014	6