



**FCC CFR47 PART 22H AND 24E  
INDUSTRY CANADA RSS-132 AND RSS-133  
CERTIFICATION TEST REPORT**

**FOR**

**RUGGEDIZED HANDHELD PDA-TYPE DEVICE W/DUAL BAND  
GSM/GPRS/WCDMA/HSDPA**

**MODEL NUMBER: CN4, CN4e\*\***

**FCC ID: EHA-01CN4**

**IC: 1223A-01CN4**

**REPORT NUMBER: 09U12493-3, Revision A  
ISSUE DATE: JUNE 04, 2009**

*Prepared for*

**INTERMEC TECHNOLOGIES CORP.  
550 SECOND STREET SE  
CEDAR RAPIDS, IOWA 52401, U.S.A.**

*Prepared by*

**COMPLIANCE CERTIFICATION SERVICES  
47173 BENICIA STREET  
FREMONT, CA 94538, U.S.A.  
TEL: (510) 771-1000  
FAX: (510) 661-0888**

\*\* Model differences are described within the body of this report



NVLAP LAB CODE 200065-0

Revision History

<u>Rev.</u>	<u>Issue Date</u>	<u>Revisions</u>	<u>Revised By</u>
--	05/27/09	Initial Issue	T. Chan
A	06/04/09	Updated EUT description and removed all the related test result data of HSUPA from the report	A. Zaffar

## TABLE OF CONTENTS

<b>1. ATTESTATION OF TEST RESULTS</b> .....	<b>4</b>
<b>2. TEST METHODOLOGY</b> .....	<b>5</b>
<b>3. FACILITIES AND ACCREDITATION</b> .....	<b>5</b>
<b>4. CALIBRATION AND UNCERTAINTY</b> .....	<b>5</b>
4.1. <i>MEASURING INSTRUMENT CALIBRATION</i> .....	5
4.2. <i>MEASUREMENT UNCERTAINTY</i> .....	5
<b>5. EQUIPMENT UNDER TEST</b> .....	<b>6</b>
5.1. <i>DESCRIPTION OF EUT</i> .....	6
5.2. <i>DESCRIPTION OF MODEL(S) DIFFERENCES</i> .....	6
5.3. <i>DESCRIPTION OF AVAILABLE ANTENNAS</i> .....	6
5.4. <i>DESCRIPTION OF TEST SETUP</i> .....	6
<b>6. TEST AND MEASUREMENT EQUIPMENT</b> .....	<b>9</b>
<b>7. TEST SUMMARY</b> .....	<b>10</b>
<b>8. MAXIMUM OUTPUT POWER</b> .....	<b>10</b>
<b>9. RF POWER OUTPUT VERIFICATION</b> .....	<b>11</b>
9.1. <i>RF POWER OUTPUT FOR GSM MODE</i> .....	12
9.2. <i>RF POWER OUTPUT FOR UMTS REL99 MODE</i> .....	13
9.3. <i>RF POWER OUTPUT FOR UMTS HSDPA MODE</i> .....	14
<b>10. WORST-CASE CONFIGURATION AND MODE</b> .....	<b>16</b>
<b>11. CONDUCTED TEST RESULTS</b> .....	<b>17</b>
11.1. <i>OCCUPIED BANDWIDTH</i> .....	17
11.2. <i>BAND EDGE</i> .....	34
11.3. <i>OUT OF BAND EMISSIONS</i> .....	43
11.4. <i>FREQUENCY STABILITY</i> .....	60
<b>12. RADIATED TEST RESULTS</b> .....	<b>65</b>
12.1. <i>RADIATED POWER (ERP &amp; EIRP)</i> .....	65
12.2. <i>FIELD STRENGTH OF SPURIOUS RADIATION</i> .....	71
12.3. <i>RECEIVER SPURIOUS EMISSIONS</i> .....	80
12.4. <i>POWER LINE CONDUCTED EMISSION</i> .....	89
<b>13. SETUP PHOTOS</b> .....	<b>93</b>

# 1. ATTESTATION OF TEST RESULTS

**COMPANY NAME:** INTERMEC TECHNOLOGIES CORP  
550 SECOND STREET SE  
CEDAR RAPIDS, IOWA, 52401, U.S.A

**EUT DESCRIPTION:** RUGGEDIZED HANDHELD PDA-TYPE DEVICE w/ DUAL BAND  
GSM/GPRS/WCDMA/HSDPA

**MODEL:** CN4, CN4e

**SERIAL NUMBER:** 03590990181, 03590990054

**DATE TESTED:** APRIL 27 – MAY 11, 2009

APPLICABLE STANDARDS	
STANDARD	TEST RESULTS
FCC PART 22H and 24E	Pass
IC RSS-132 ISSUE 2 and RSS-133 ISSUE 4	Pass

Compliance Certification Services, Inc. (CCS) tested the above equipment in accordance with the requirements set forth in the above standards. All expressions of Pass/Fail in this report are opinions expressed by CCS based on interpretations of the test results. The test results show that the equipment tested is capable of demonstrating compliance with the requirements as documented in this report.

**Note:** The results documented in this report apply only to the tested sample, under the conditions and modes of operation as described herein. This document may not be altered or revised in any way unless done so by CCS and all revisions are duly noted in the revisions section. Any alteration of this document not carried out by CCS will constitute fraud and shall nullify the document. No part of this report may be used to claim product certification, approval, or endorsement by NVLAP, NIST, or any government agency.

Approved & Released For CCS By:

Tested By:

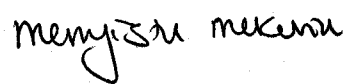

THU CHAN  
EMC MANAGER  
COMPLIANCE CERTIFICATION SERVICES

MENGISTU MEKURIA  
EMC ENGINEER  
COMPLIANCE CERTIFICATION SERVICES

## 2. TEST METHODOLOGY

The tests documented in this report were performed in accordance with RSS-GEN, RSS-132, RSS-133, ANSI/TIA 603C-2004, FCC CFR 47 Part 2, and FCC CFR 47 Part 22 and 24.

## 3. FACILITIES AND ACCREDITATION

The test sites and measurement facilities used to collect data are located at 47173 Benicia Street, Fremont, California, USA.

CCS is accredited by NVLAP, Laboratory Code 200065-0. The full scope of accreditation can be viewed at <http://www.ccsemc.com>.

## 4. CALIBRATION AND UNCERTAINTY

### 4.1. MEASURING INSTRUMENT CALIBRATION

The measuring equipment utilized to perform the tests documented in this report has been calibrated in accordance with the manufacturer's recommendations, and is traceable to recognized national standards.

### 4.2. MEASUREMENT UNCERTAINTY

Where relevant, the following measurement uncertainty levels have been estimated for tests performed on the apparatus:

PARAMETER	UNCERTAINTY
Radiated Emission, 30 to 200 MHz	+/- 3.3 dB
Radiated Emission, 200 to 1000 MHz	+4.5 / -2.9 dB
Radiated Emission, 1000 to 2000 MHz	+4.5 / -2.9 dB
Power Line Conducted Emission	+/- 2.9 dB

Uncertainty figures are valid to a confidence level of 95%.

## 5. EQUIPMENT UNDER TEST

### 5.1. DESCRIPTION OF EUT

The EUT is a ruggedized handheld PDA-type device w/dual-band GSM / GPRS / WCDMA / HSDPA, 802.11b/g & BT.

### 5.2. DESCRIPTION OF MODEL(S) DIFFERENCES

CN4 is standard and CN4e is extended, both are available with numeric or QWERTY keypads. CN4e with QWERTY keypad was selected as a representative model for radiated emissions and radiated immunity testing.

### 5.3. DESCRIPTION OF AVAILABLE ANTENNAS

TRANSMITTER SPECIFICATIONS			
REGION	BAND ( MHz)	AUTHORIZED FREQUENCY RANGE (MHz)	PEAK ANTENNA GAIN (dBi)
US	850.00	824 to 849	1.14
US	1900.00	1850 to 1910	1.59

### 5.4. DESCRIPTION OF TEST SETUP

#### SUPPORT EQUIPMENT

PERIPHERAL SUPPORT EQUIPMENT LIST				
Description	Manufacturer	Model	Serial Number	FCC ID
AC Adapter	Intermec Tech. Corp.	73575	990397	N/A
Single Dock Charger	Intermec Tech. Corp.	AD 10	N/A	N/A

#### I/O CABLES (CONDUCTED TEST)

I/O CABLE LIST						
Cable No.	Port	# of Identical Ports	Connector Type	Cable Type	Cable Length	Remarks
1	AC	1	US 115V	Un-shielded	2m	No
2	DC	1	DC	Un-shielded	2m	Ferrite at one end

#### TEST SETUP

The EUT is a standalone unit during the tests. The wireless link is established between the EUT and the Agilent 8960 communications test set.

**SETUP DIAGRAM FOR RF CONDUCTED TESTS**

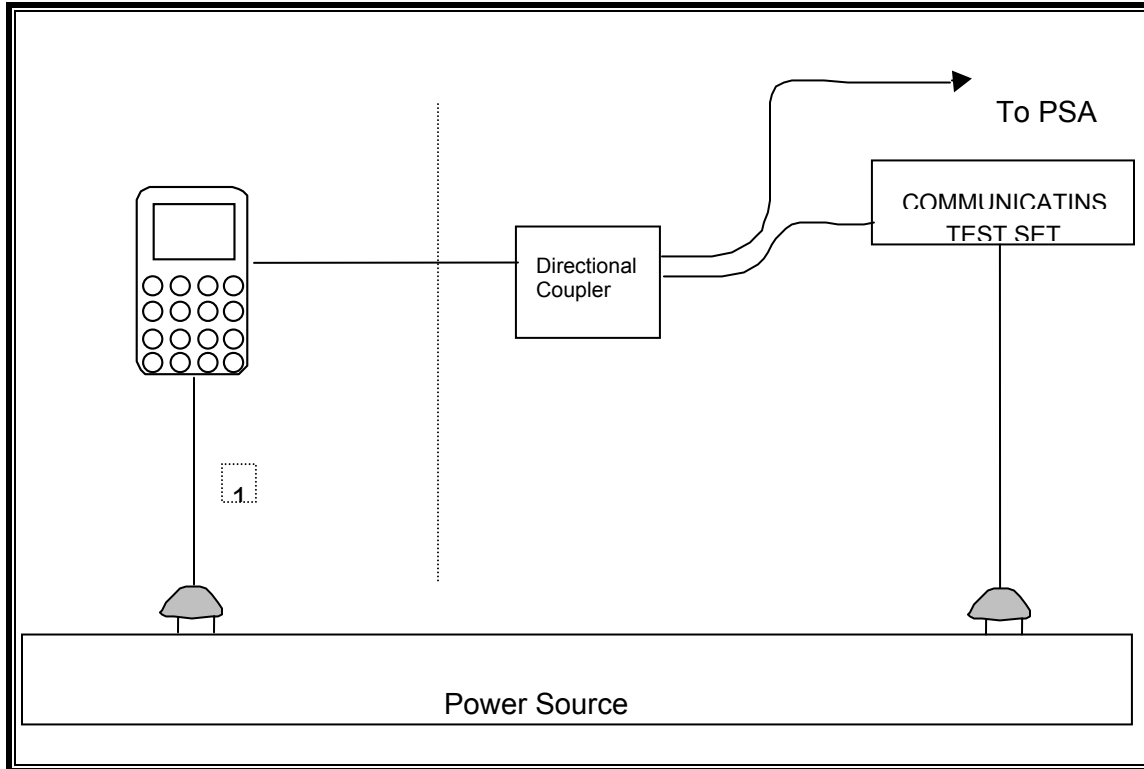

**SETUP DIAGRAM FOR RF RADIATED TESTS**

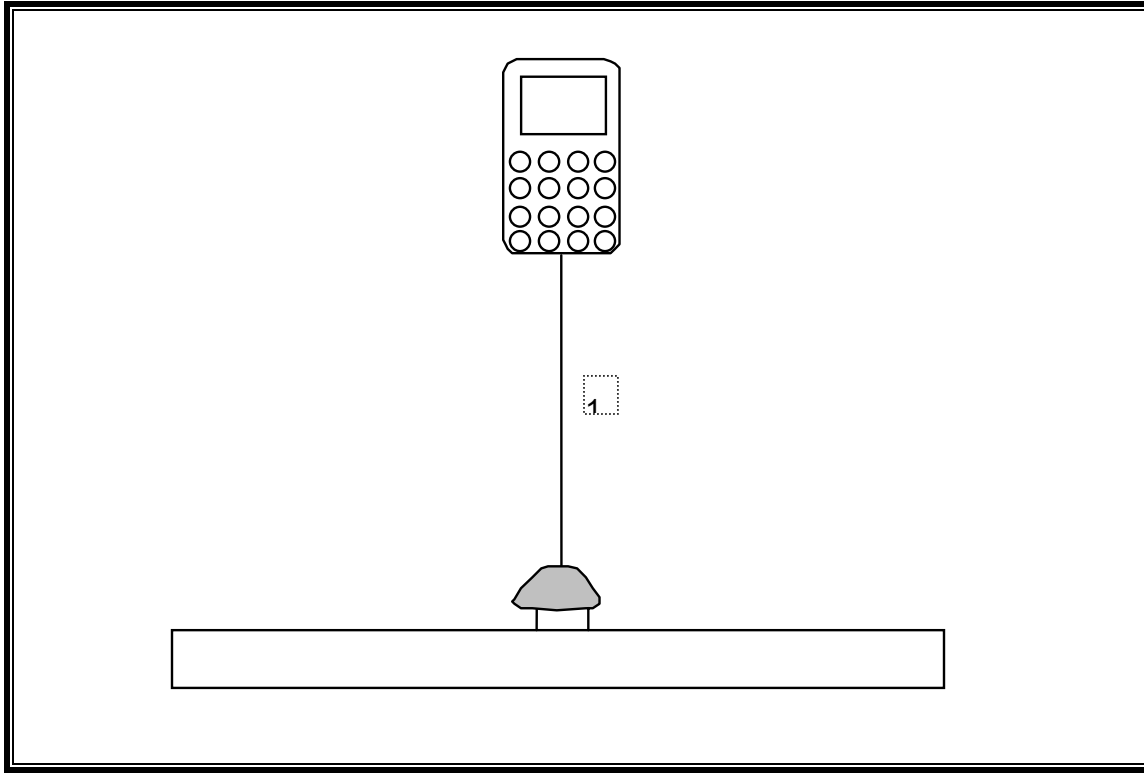



## 6. TEST AND MEASUREMENT EQUIPMENT

The following test and measurement equipment was utilized for the tests documented in this report:

TEST EQUIPMENT LIST				
Description	Manufacturer	Model	Asset	Cal Due
Spectrum Analyzer, 44 GHz	Agilent / HP	E4446A	C01012	03/03/10
Temperature / Humidity	Thermotron	SE 600-10-10	C00930	04/06/10
Antenna, Horn, 18 GHz	ETS	3117	C01006	04/22/10
Preamplifier, 26.5 GHz	Agilent / HP	8449B	C01063	08/05/09
EMI Receiver, 2.9 GHz	Agilent / HP	8542E	C00957	09/19/09
RF Filter Section, 2.9 GHz	Agilent / HP	85420E	C00958	09/19/09
EMI Test Receiver, 30 MHz	R & S	ESHS 20	N02396	08/06/09
Communications Test Set	Agilent / HP	E5515C	C01086	06/16/09
Antenna, Bilog, 2 GHz	Sunol Sciences	JB1	C01011	02/11/10
Preamplifier, 1300 MHz	Agilent / HP	8447D	C01064	03/31/10
LISN, 30 MHz	FCC	LISN-50/250-25-2	N02625	10/29/09

## 7. TEST SUMMARY

Description of test	Rule part		Results
	FCC	IC	
1. RF Power Output	§2.1046	RSS-132, 4.4; RSS-133, 6.4;	Complies
2. Occupied Bandwidth	§2.1049	RSS-Gen, 4.6	Complies
3. Block Edge (Band Edge)	§22.359, §24.238	RSS-132, 4.5; RSS-133, 6.5	Complies
4. Out of Band Emissions	§2.1051, §22.917, §24.238	RSS-132, 4.5; RSS-133, 6.5	Complies
5. Frequency Stability	§2.1055, §22.355, §24.235	RSS-132, 4.3; RSS-133, 6.3	Complies
6. Radiated Power (ERP & EIRP)	§2.1046, §22.913, §24.232	RSS-132; 4.4, RSS-133, 6.4	Complies
7. Field Strength of Spurious Radiation	§2.1053, §22.917, §24.238	RSS-132, 4.5; RSS-133, 6.5	Complies
8. Receiver Spurious Emissions (IC only)	n/a	RSS-132, 4.6; RSS-133, 6.6, RSS-Gen	Complies

## 8. MAXIMUM OUTPUT POWER

The transmitter has a maximum output power as follows:

### Part 22 Cellular Band

Frequency range (MHz)	Modulation	Peak Conducted Power		ERP	
		dBm	mW	dBm	mW
824.2 – 848.8	GPRS	31.72	1485.9	28.50	707.9
	EGPRS	26.68	465.6	27.40	549.5
826.4 – 846.6	UMTS - Rel 99	27.10	512.9	23.50	223.9
	UMTS - HSDPA	26.41	437.5	23.80	239.9

### Part 24 PCS Band

Frequency range (MHz)	Modulation	Peak Conducted Power		EIRP	
		dBm	mW	dBm	mW
1850.2 – 1909.8	GPRS	29.50	891.3	32.7	1862.1
	EGPRS	26.19	415.9	32.3	1698.2
1852.4 – 1907.6	UMTS - Rel 99	26.70	467.7	30.0	1000.0
	UMTS - HSDPA	27.01	502.3	29.6	912.0

## **9. RF POWER OUTPUT VERIFICATION**

### **RULE PART(S)**

FCC: §2.1046  
IC: RSS-132, 4.4; RSS-133, 6.4

### **LIMITS**

For reporting purposes only

### **TEST PROCEDURE**

The transmitter output was connected to an Agilent 8960 Test Set and configured to operate at maximum power in a call. The peak power was measured using the spectrum analyzer at three equally spaced operating frequencies for each band. The RBW was set to 300 KHz for the GSM and EDGE measurements and 5 MHz for the UMTS (WCDMA) measurements.

### **MODES TESTED**

- GSM, EGPRS, Rel 99 & HSDPA Rel 6 Subtest 2.

### **RESULTS**

See Section 9.1 to 9.4

## 9.1. RF POWER OUTPUT FOR GSM MODE

### GSM (GPRS)

Band	Ch	Frequency	Conducted output power (dBm)	
			Average	Peak
GSM850	128	824.2	31.58	31.68
	190	836.6	31.51	31.61
	251	848.8	31.58	31.68
GSM1900	512	1850.2	29.36	29.48
	661	1880.0	29.31	29.42
	810	1909.8	29.36	29.48

### GPRS (GPRS) - Coding scheme: MCS4

Band	Ch	Frequency	Conducted output power (dBm)			
			Average		Peak	
			1 slot	2 slot	1 slot	2 slot
GSM850	128	824.2	31.59	30.03	31.72	30.14
	190	836.6	31.51	29.80	31.64	30.07
	251	848.8	31.59	30.05	<b>31.72</b>	30.15
GSM1900	512	1850.2	28.38	27.77	<b>29.50</b>	27.87
	661	1880	29.33	27.71	29.45	27.81
	810	1909.8	29.37	27.74	29.49	27.86

### EGPRS (EGPRS) - Coding scheme: MCS9

Band	Ch	Frequency	Conducted output power (dBm)			
			Average		Peak	
			1 slot	2 slot	1 slot	2 slot
GSM850	128	824.2	26.56	26.51	26.67	26.62
	190	836.6	26.50	26.46	26.62	26.59
	251	848.8	26.56	26.53	<b>26.68</b>	26.65
GSM1900	512	1850.2	26.08	26.01	26.19	26.12
	661	1880	26.03	25.98	26.14	26.10
	810	1909.8	26.07	26.02	<b>26.19</b>	26.13

## 9.2. RF POWER OUTPUT FOR UMTS REL99 MODE

The following tests were completed according to the test requirements outlined in section 5.2 of the 3GPP TS34.121-1 V7.5.0 specification. The EUT supports power Class 3, which has a nominal maximum output power of 24 dBm (+1.7/-3.7) 12.2kps RMC is used for this testing. Power control set to All bits up. A summary of these settings are illustrated below:

	Mode	Rel99
	Subtest	-
WCDMA General Settings	Loopback Mode	Test Mode 1
	Rel99 RMC	12.2kbps RMC
	HSUPA FRC	Not Applicable
	HSUPA Test	Not Applicable
	Power Control Algorithm	Algorithm2
	$\beta_c$	Not Applicable
	$\beta_d$	Not Applicable
	$\beta_{ec}$	Not Applicable
	$\beta_c/\beta_d$	8/15
	$\beta_{hs}$	Not Applicable
	$\beta_{ed}$	Not Applicable

### REL 99

Band	UL Ch	DL Ch	Frequency	Conducted output power (dBm)	
				Average	Peak
UMTS850 (Band V)	4132	4357	826.4	24.60	26.72
	4180	4405	836.0	24.50	26.80
	4230	4455	846.0	24.55	<b>27.10</b>
UMTS1900 (Band II)	9262	9662	1852.4	24.80	26.50
	9400	9800	1880	24.56	<b>26.70</b>
	9538	9938	1907.6	24.50	26.21

### 9.3. RF POWER OUTPUT FOR UMTS HSDPA MODE

The following 4 Sub-tests were completed according to Release 5 procedures in section 5.2 of 3GPP TS34.121. A summary of these settings are illustrated below:

	Mode	Rel6 HSDPA	Rel6 HSDPA	Rel6 HSDPA	Rel6 HSDPA
	Subtest	1	2	3	4
WCDMA General Settings	Loopback Mode	Test Mode 1			
	Rel99 RMC	12.2kbps RMC			
	HSDPA FRC	H-Set1			
	HSUPA Test	Not Applicable			
	Power Control Algorithm	Algorithm 2			
	$\beta_c$	2/15	12/15	15/15	15/15
	$\beta_d$	15/15	15/15	8/15	4/15
	Bd (SF)	64			
	$\beta_{ec}$	-	-	-	-
	$\beta_c/\beta_d$	2/15	12/15	15/8	15/4
	$\beta_{hs}$	4/15	24/15	30/15	30/15
	$\beta_{ed}$	Not Applicable			
	CM (dB)	0	1	1.5	1.5
	MPR (dB)	0	0	0.5	0.5
HSDPA Specific Settings	DACK	8			
	DNAK	8			
	DCQI	8			
	Ack-Nack repetition factor	3			
	CQI Feedback (Table 5.2B.4)	4ms			
	CQI Repetition Factor (Table 5.2B.4)	2			
	Ahs = $\beta_{hs}/\beta_c$	30/15			

**REL 6 HSDPA**

Band	Subtest	UL Ch	DL Ch	Frequency	Conducted output power (dBm)	
					Average	Peak
UMTS850 (Band V)	1	4132	4357	826.4	24.80	25.87
		4180	4405	836.0	24.30	26.02
		4230	4455	846.0	24.20	26.03
	2*	4132	4357	826.4	24.30	25.90
		4180	4405	836.0	24.50	26.01
		4230	4455	846.0	24.42	26.01
	3	4132	4357	826.4	23.70	26.00
		4180	4405	836.0	23.60	26.05
		4230	4455	846.0	23.80	26.05
	4	4132	4357	826.4	23.75	25.91
		4180	4405	836.0	23.68	26.02
		4230	4455	846.0	23.65	26.01
UMTS1900 (Band II)	1	9262	9662	1852.4	24.20	26.47
		9400	9800	1880.0	24.33	26.68
		9538	9938	1907.6	24.35	26.29
	2*	9262	9662	1852.4	24.40	26.47
		9400	9800	1880.0	24.30	26.70
		9538	9938	1907.6	24.56	26.35
	3	9262	9662	1852.4	24.02	26.38
		9400	9800	1880.0	23.90	26.74
		9538	9938	1907.6	24.00	26.16
	4	9262	9662	1852.4	24.20	26.49
		9400	9800	1880.0	24.30	26.64
		9538	9938	1907.6	24.30	26.12

## 10. WORST-CASE CONFIGURATION AND MODE

Based on the following investigation results, see Section 9. RF POWER OUTPUT VERIFICATION. The highest peak power and enhanced data rate is the worst-case scenario for all measurements.

Worst case modes:

- Cellular & PCS bands for GSM
  - GSM (GPRS)
  - EGPRS (EGPRS)
- Band V & Band II for UMTS (WCDMA)
  - Rel 99
  - Rel 6 HSDPA Subtest 2

During radiation test the worst-position at which the EUT generate highest emissions was also investigated. That means the fundamental power is measured in X, Y, and Z-Positions without battery charger, and EUT with battery charger. After the investigations, the worst-position was turned out to be Z-position without Battery Charger for all modulations in cell band, and Y-position without Battery Charger for all modulations in PCS band.



## 11. CONDUCTED TEST RESULTS

### 11.1. OCCUPIED BANDWIDTH

#### RULE PART(S)

FCC: §2.1049  
 IC: RSS-Gen, 4.6

#### LIMITS

For reporting purposes only

#### TEST PROCEDURE

The transmitter output was connected to a calibrated coaxial cable and coupler, the other end of which was connected to a spectrum analyzer. The occupied bandwidth was measured with the spectrum analyzer at the low, middle and high channel in each band. The -26dB bandwidth was also measured and recorded.

#### MODES TESTED

- GSM, EGPRS, Rel 99 & HSDPA Rel 6 Subtest 2.

#### RESULTS

Band	Mode	Channel	f (MHz)	99% BW (kHz)	-26dB BW (kHz)
Cellular	GPRS	128	824.2	243.0289	309.916
		190	836.6	234.9657	313.557
		251	848.8	241.3465	309.573
	EGPRS	128	824.2	242.3448	308.612
		190	836.6	245.0488	305.372
		251	848.8	244.2359	312.608
PCS	GPRS	512	1850.2	238.0217	314.916
		661	1880.0	235.6035	314.432
		810	1909.8	238.6634	312.860
	EGPRS	512	1850.2	244.2587	302.869
		661	1880.0	240.3639	314.461
		810	1909.8	244.1645	306.124

Band	Mode	Channel	f (MHz)	99% BW (MHz)	-26dB BW (MHz)
UMTS Band V	Rel 99	4132	826.4	4.2092	4.579
		4180	836.0	4.1733	4.615
		4230	846.0	4.2902	4.572
	HSDPA Rel 6 Subtest 2	4132	826.4	4.2189	4.592
		4180	836.0	4.1906	4.603
		4230	846.0	4.2312	4.621
UMTS Band II	Rel 99	9262	1852.4	4.2004	4.559
		9400	1880.0	4.1524	4.622
		9538	1907.6	4.2222	4.570
	HSDPA Rel 6 Subtest 2	9262	1852.4	4.1532	4.617
		9400	1880.0	4.1590	4.622
		9538	1907.6	4.1371	4.566

**GPRS Mode (Cellular Band)**

GPRS, Ch 128

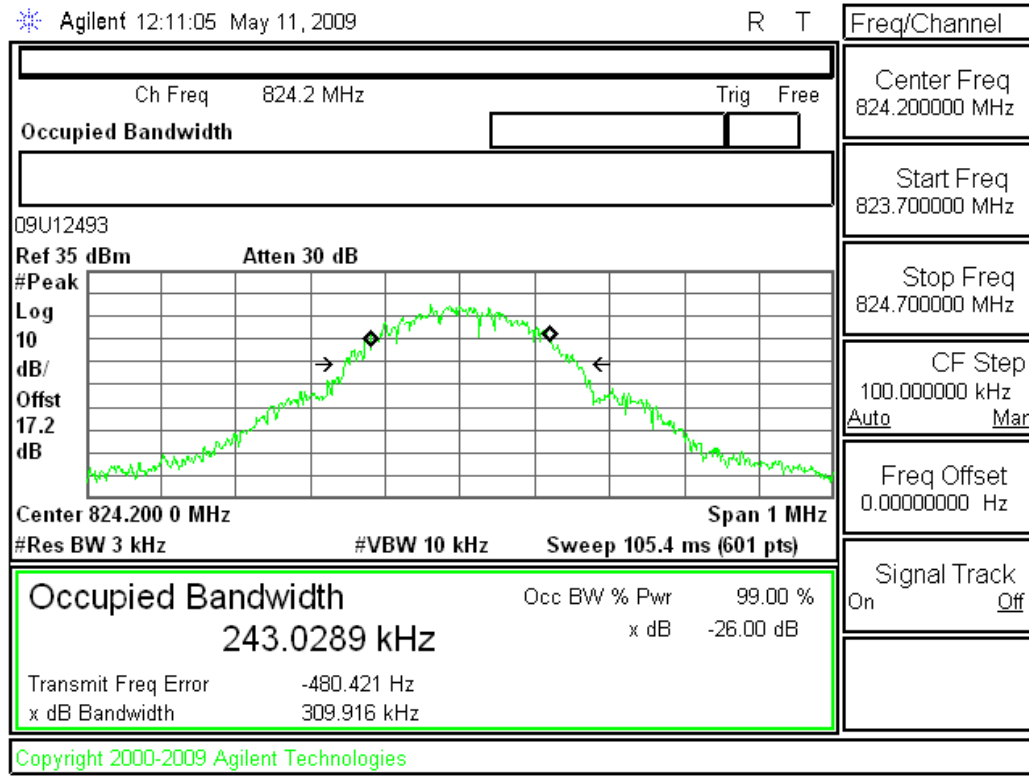

GPRS, Ch 190

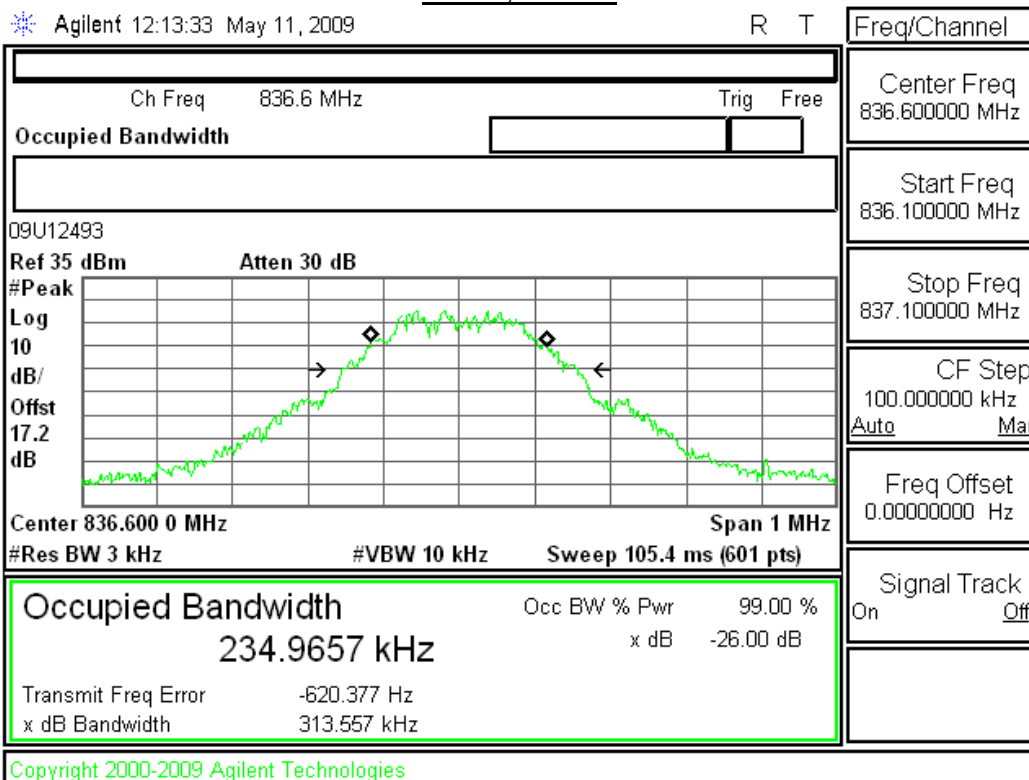

GPRS, Ch 251

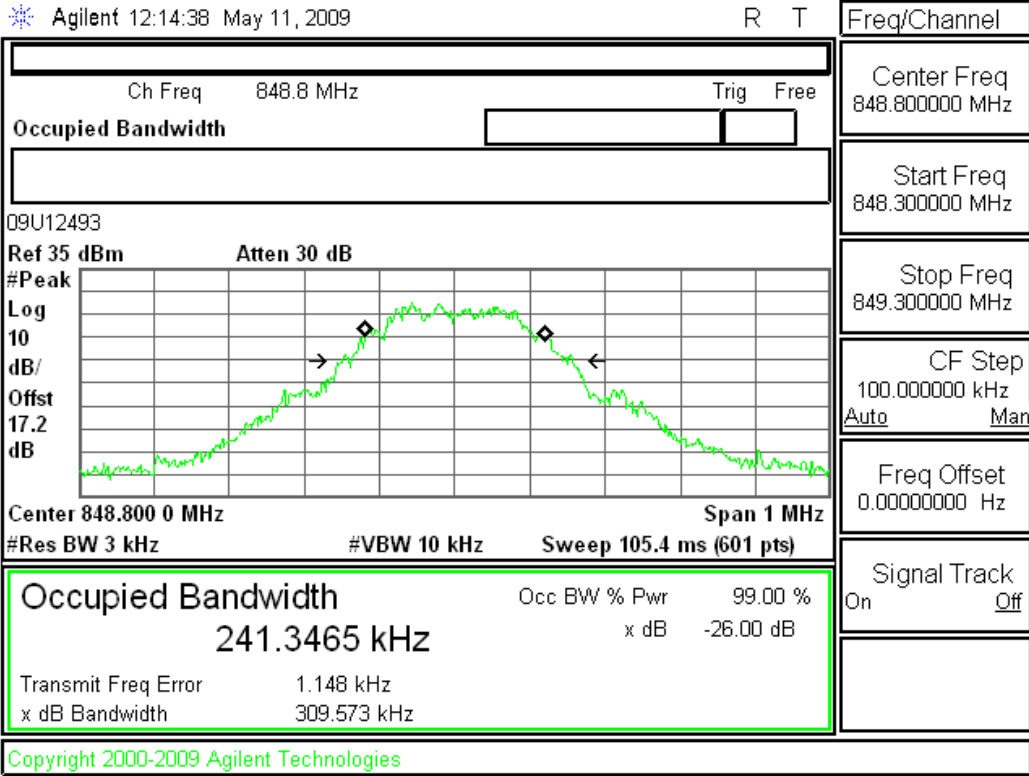

**EPGRS Mode (Cellular Band)**

**EGPRS, Ch 128**

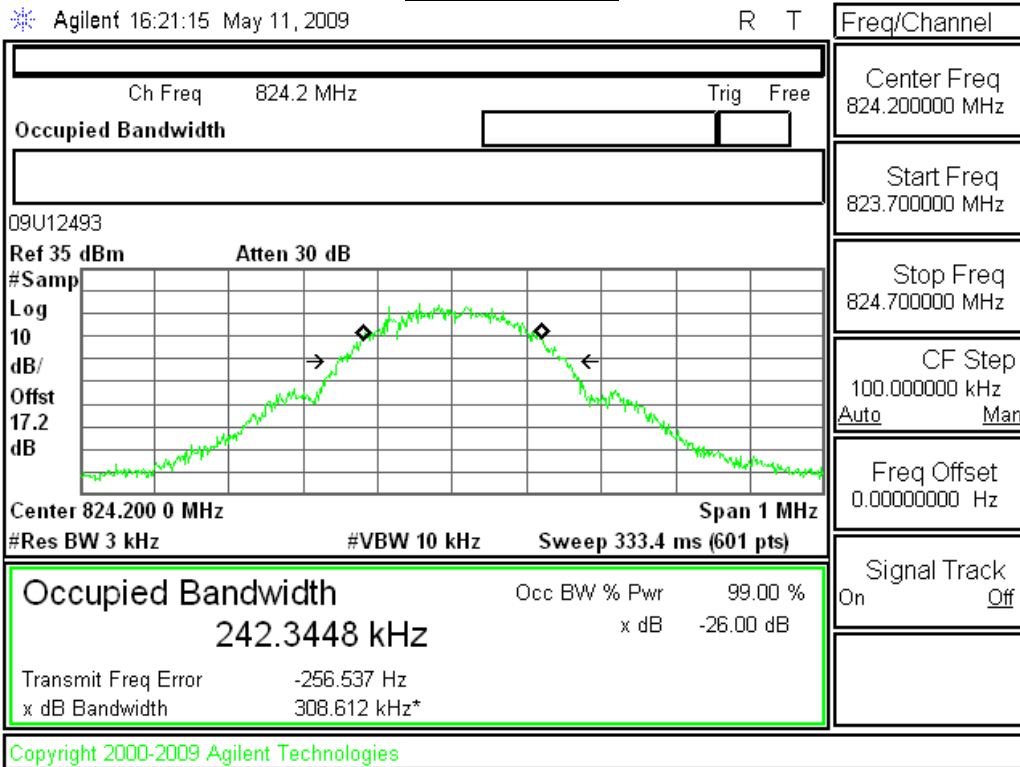

**EGPRS, Ch 190**

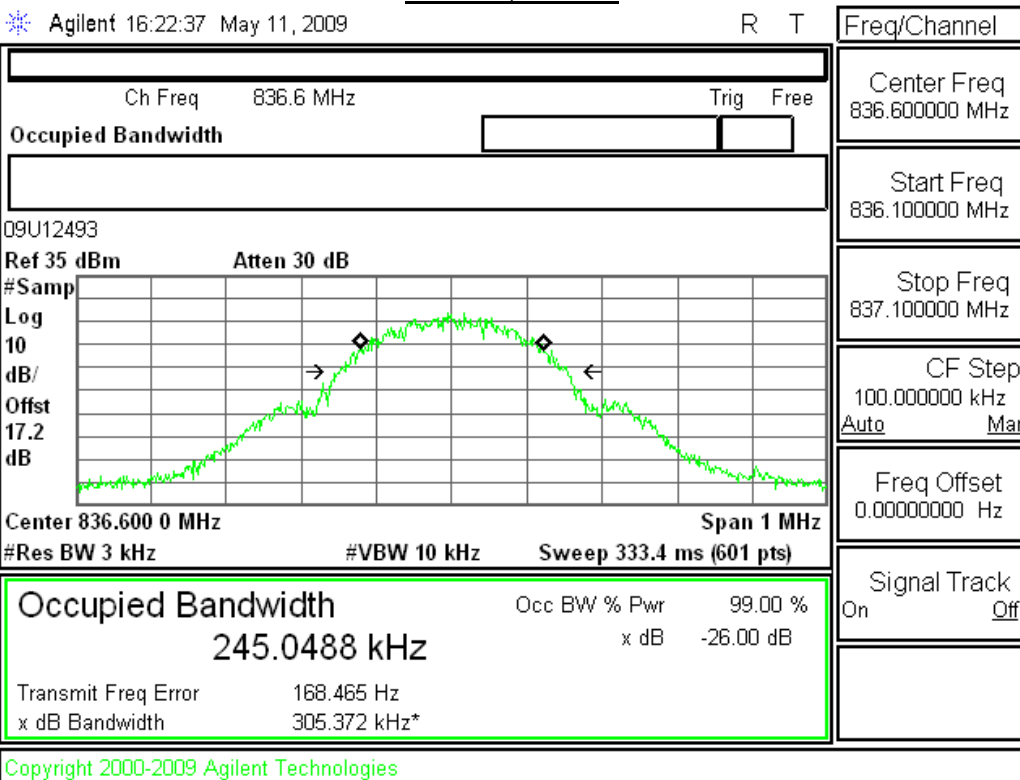

EGPRS, Ch 251

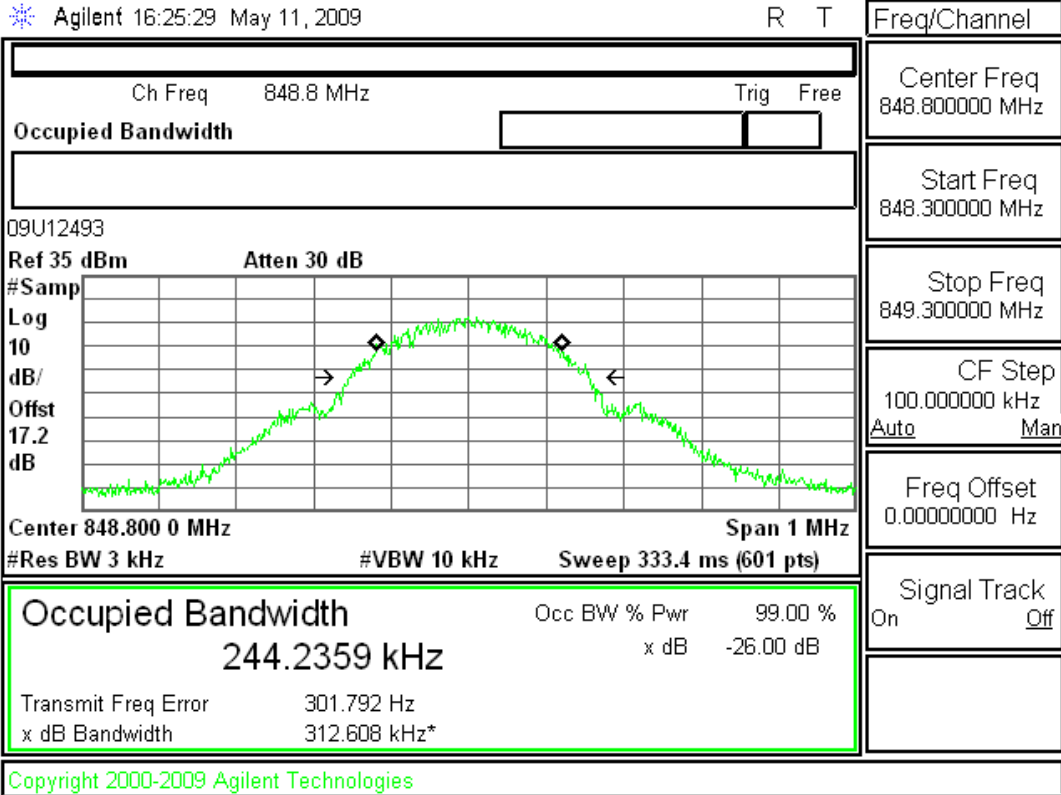

**UMTS Rel 99 Mode (Cellular Band)**

**Rel 99, Ch 4132**

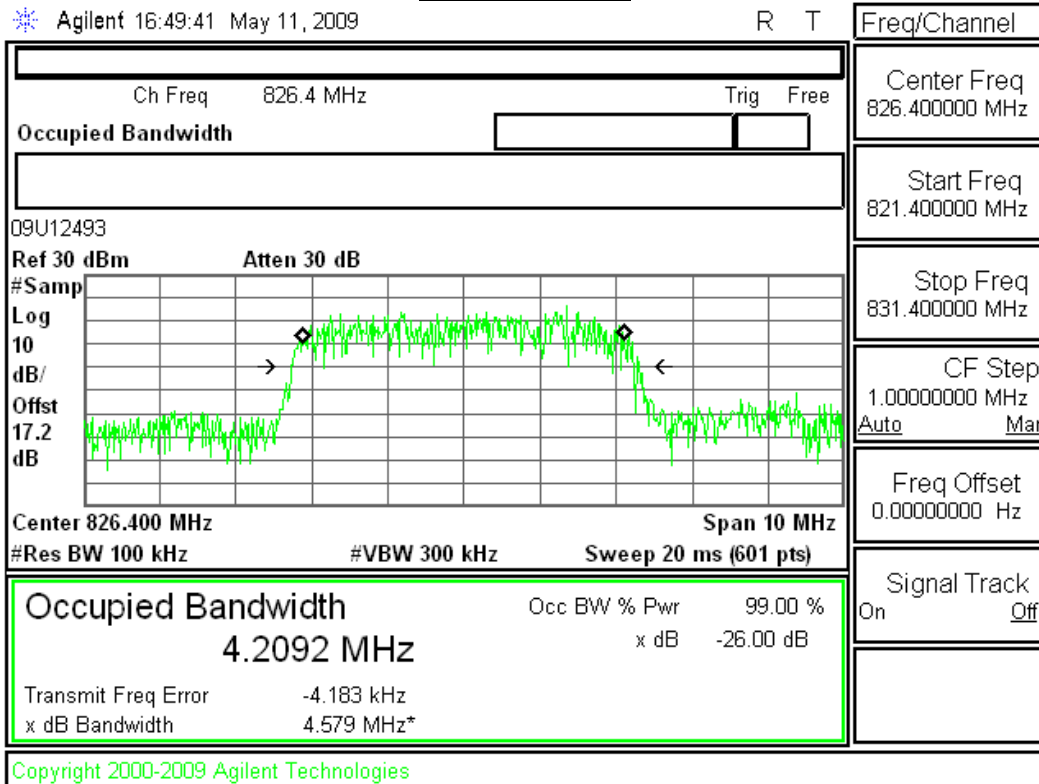

**Rel 99, Ch 4180**

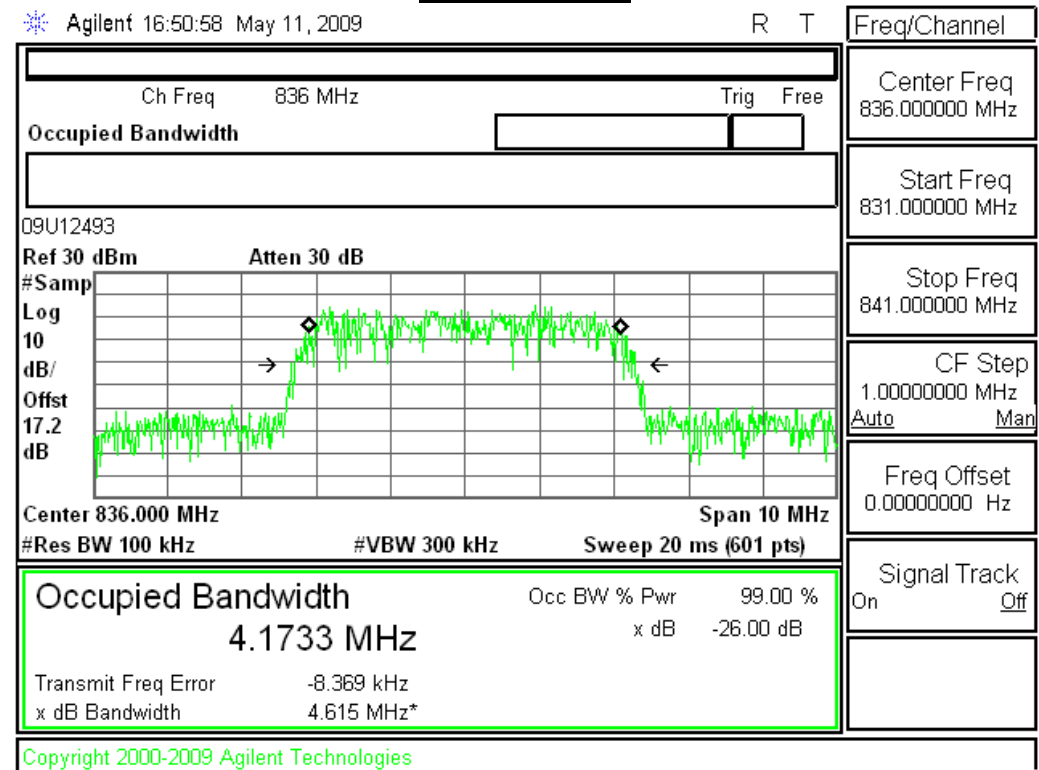

Rel 99, Ch 4230

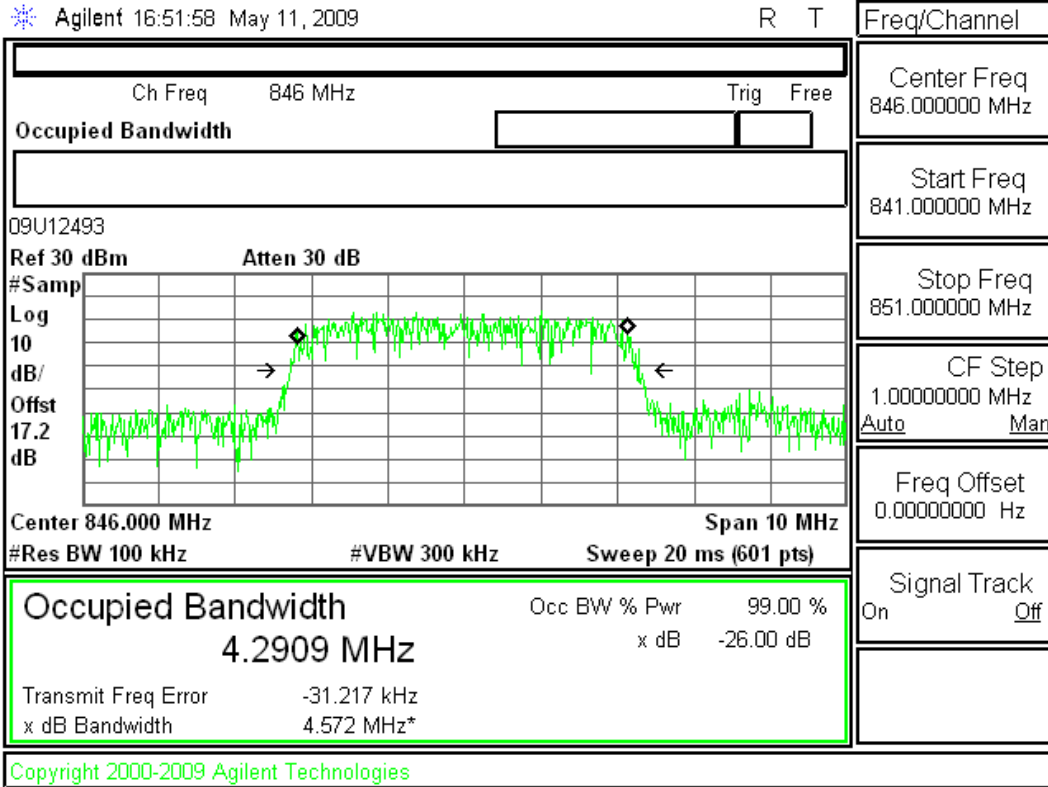

**UMTS Rel 6 HSDPA Subtest 2 Mode (Cellular Band)**

**Rel 6 HSDPA Subtest 2, Ch 4132**

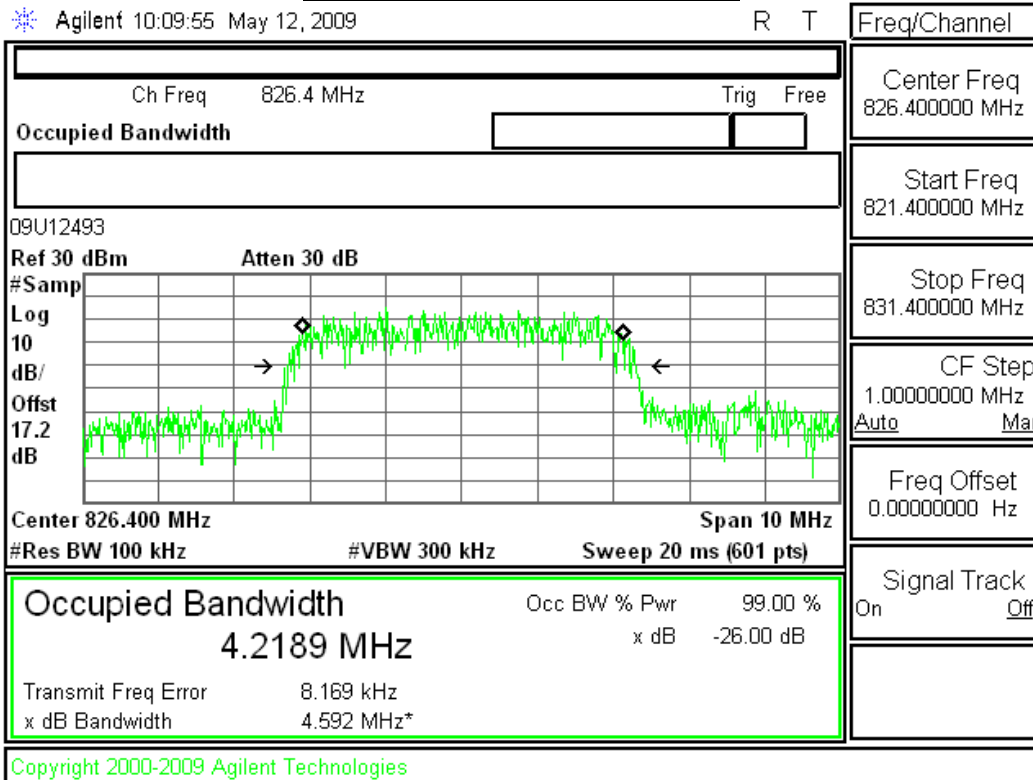

**Rel 6 HSDPA Subtest 2, Ch 4180**

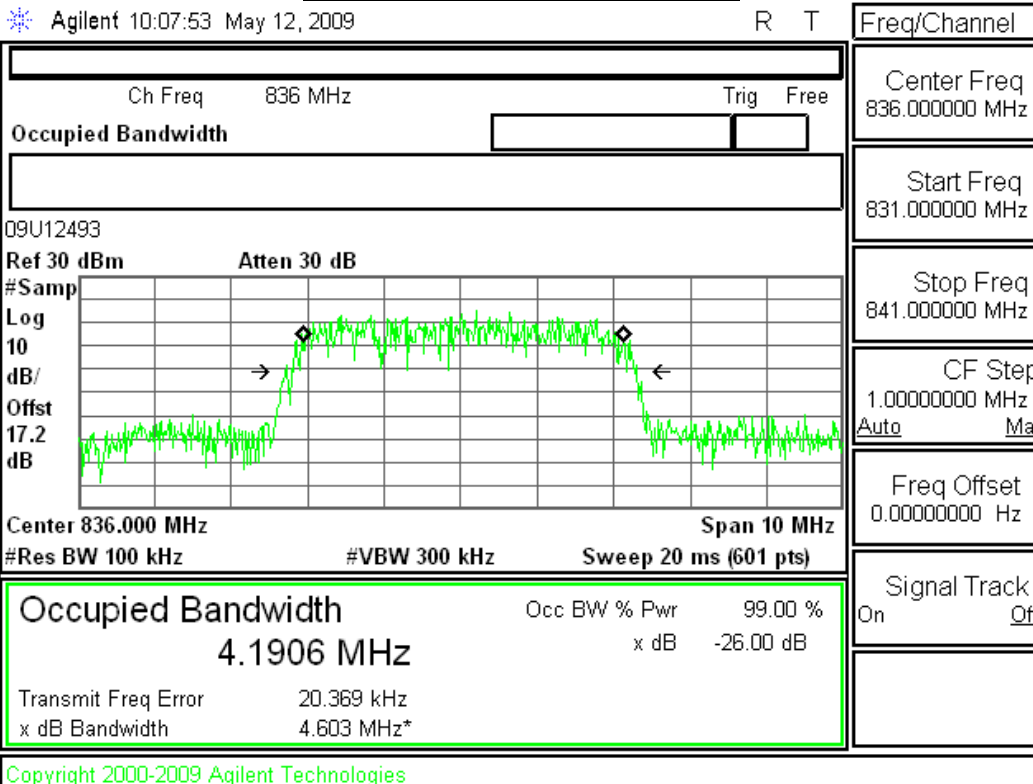



Rel 6 HSDPA Subtest 2, Ch 4230

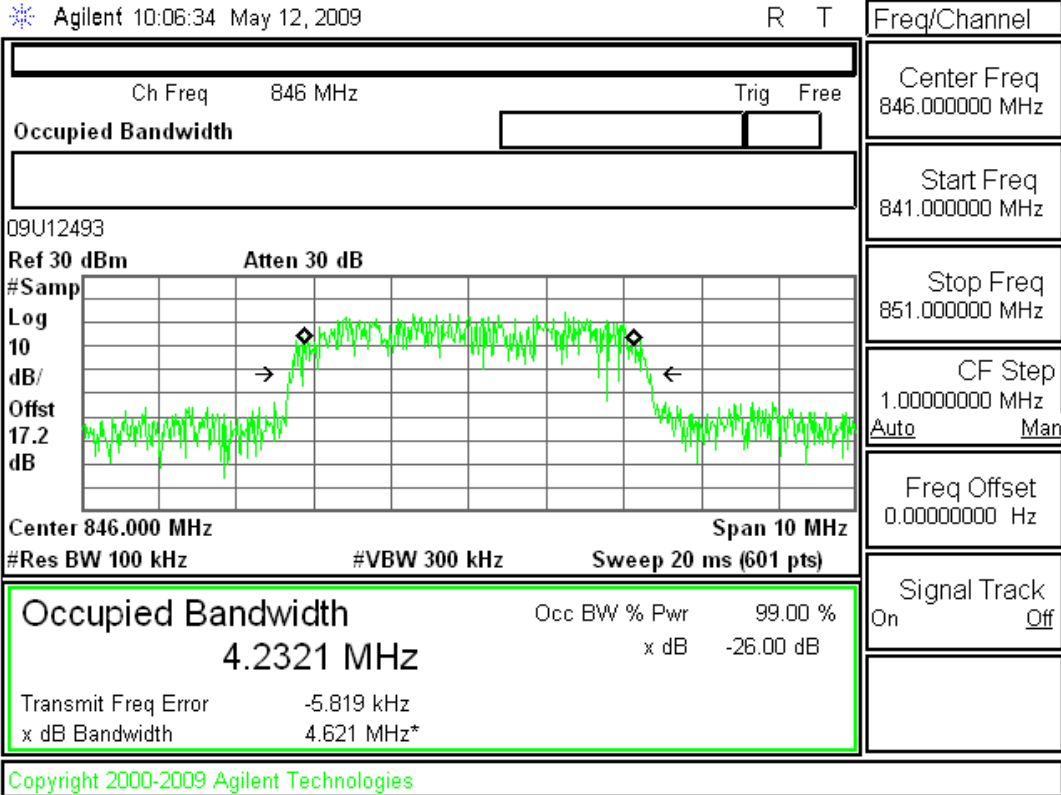

**GPRS Mode (PCS Band)**

**GPRS, Ch 512**

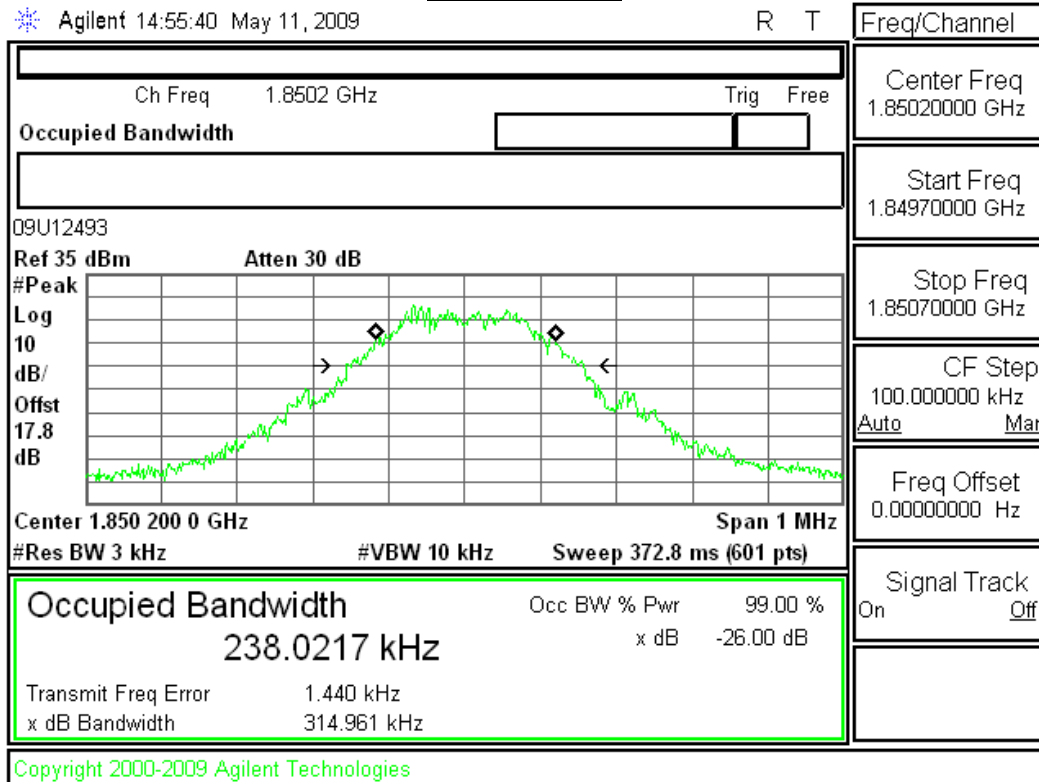

**GPRS, Ch 661**

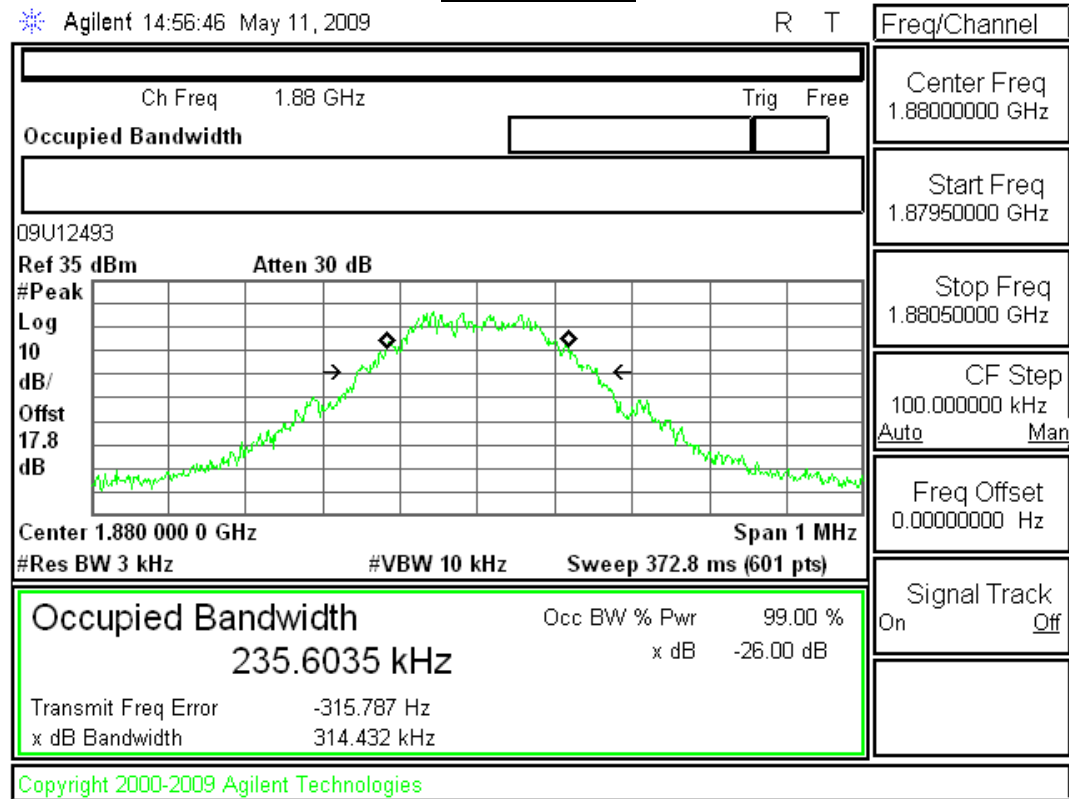

GPRS, Ch 810

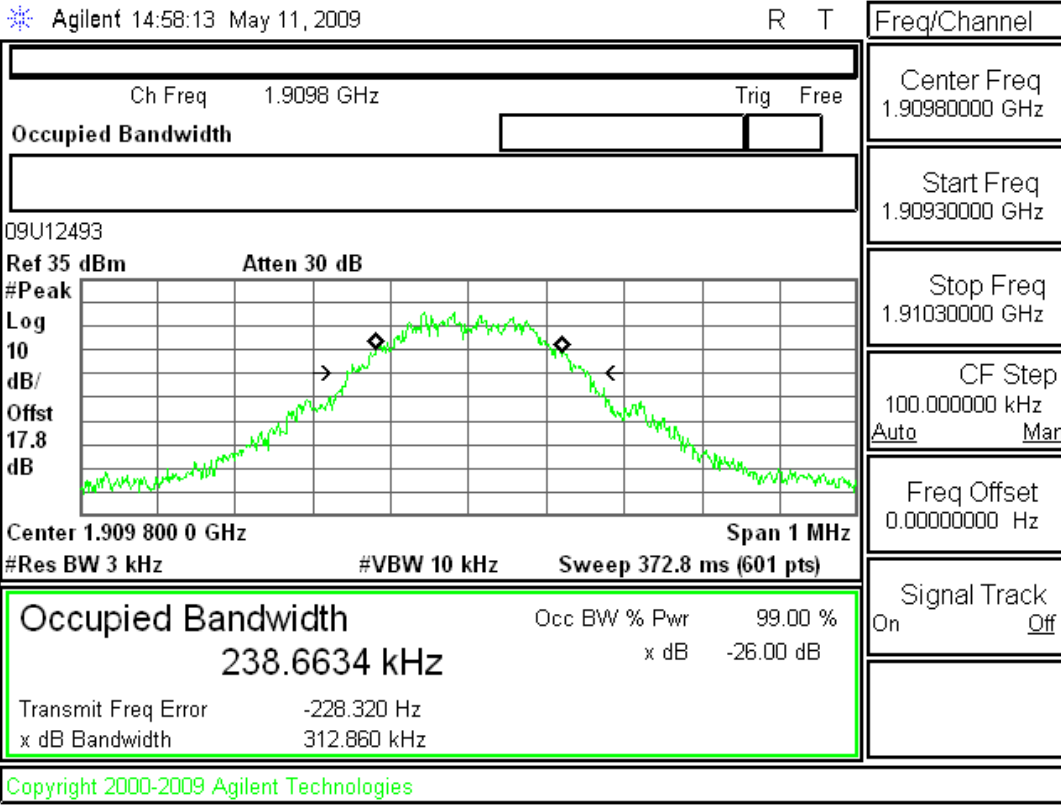

**EGPRS Mode (PCS Band)**

**EGPRS, Ch 512**

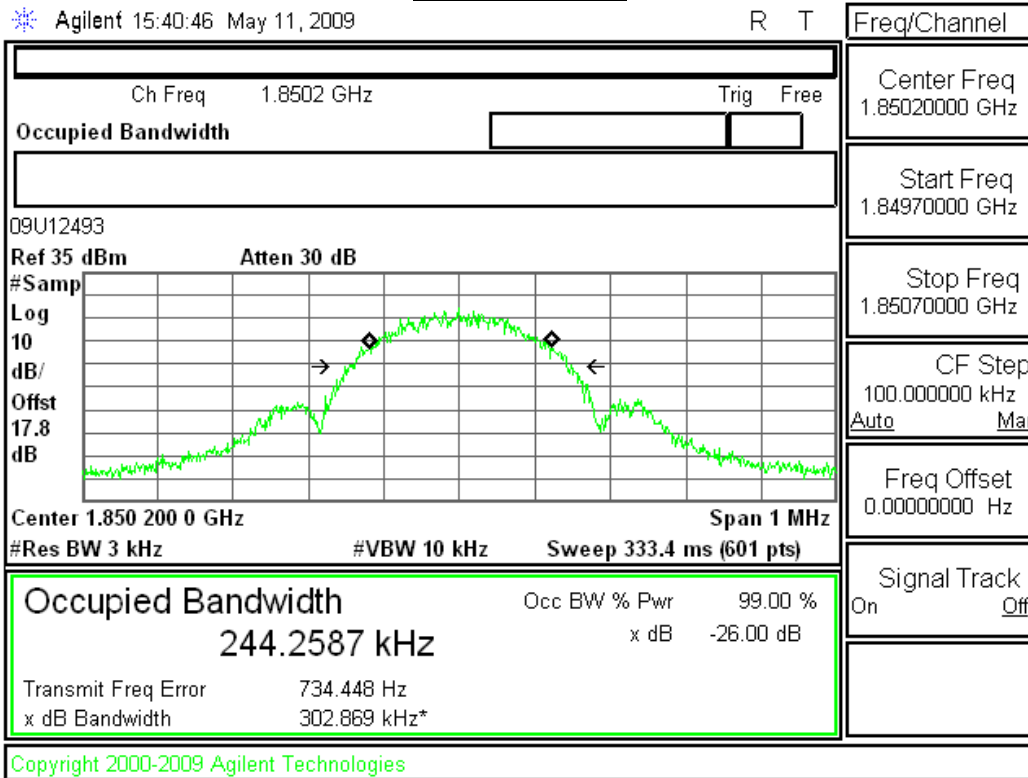

**EGPRS, Ch 661**

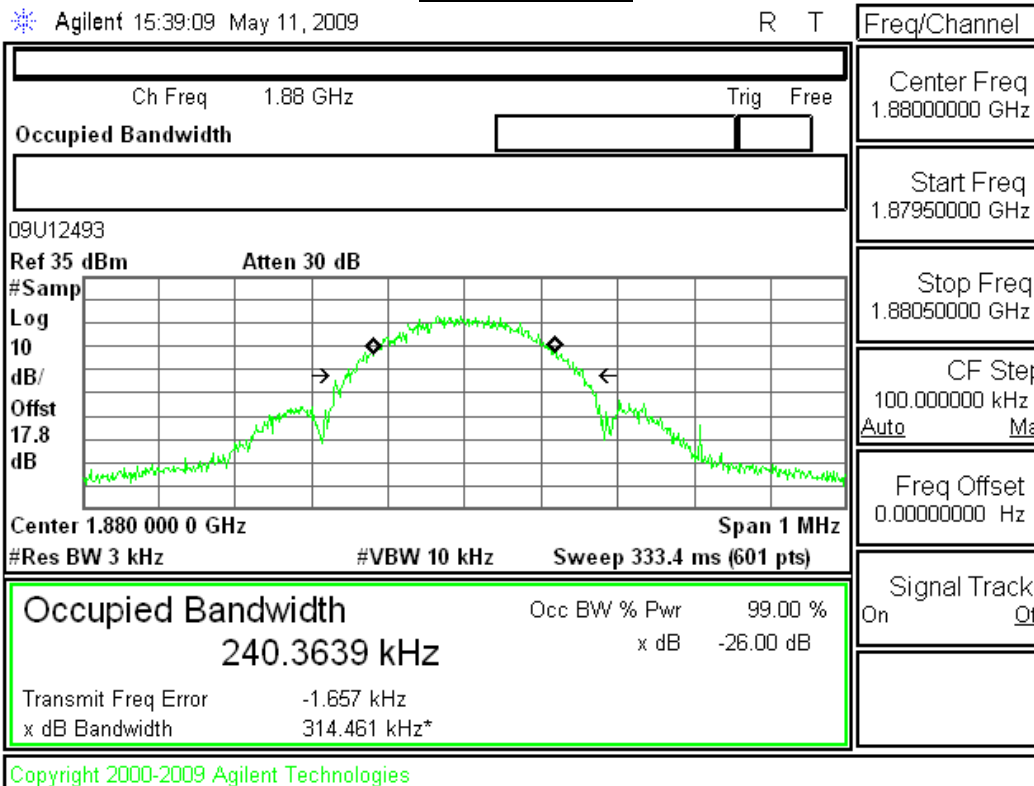

**EGPRS, Ch 810**

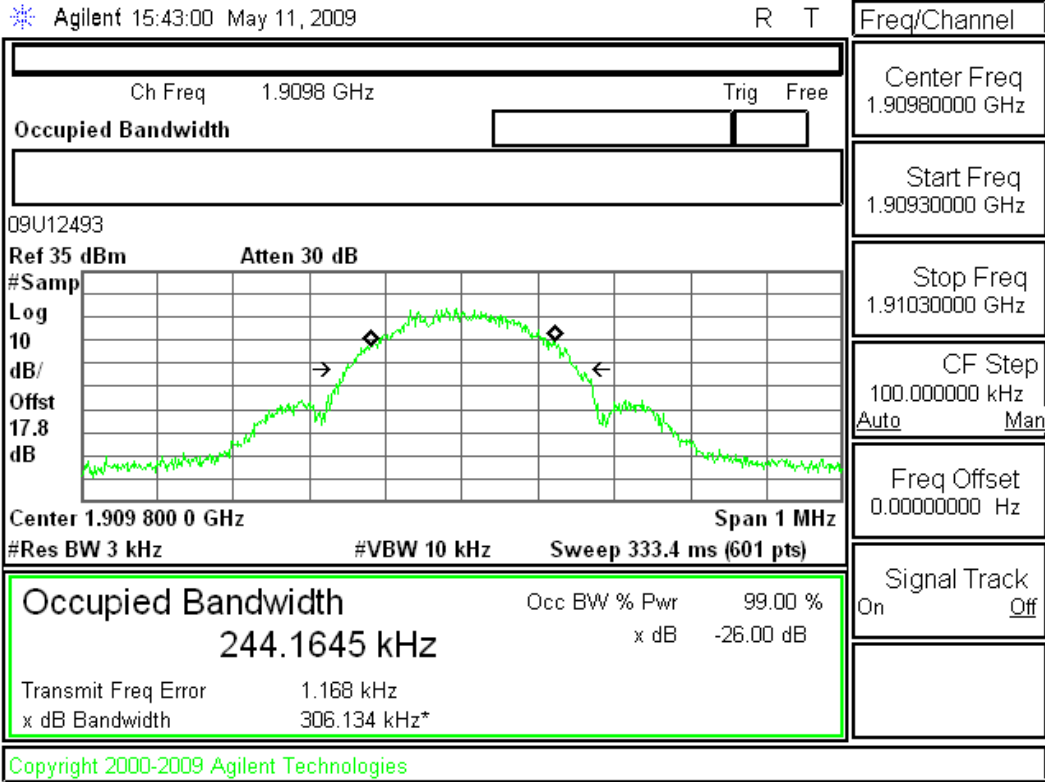

**UMTS Rel 99 Mode (PCS Band)**

Rel 99, Ch 9262

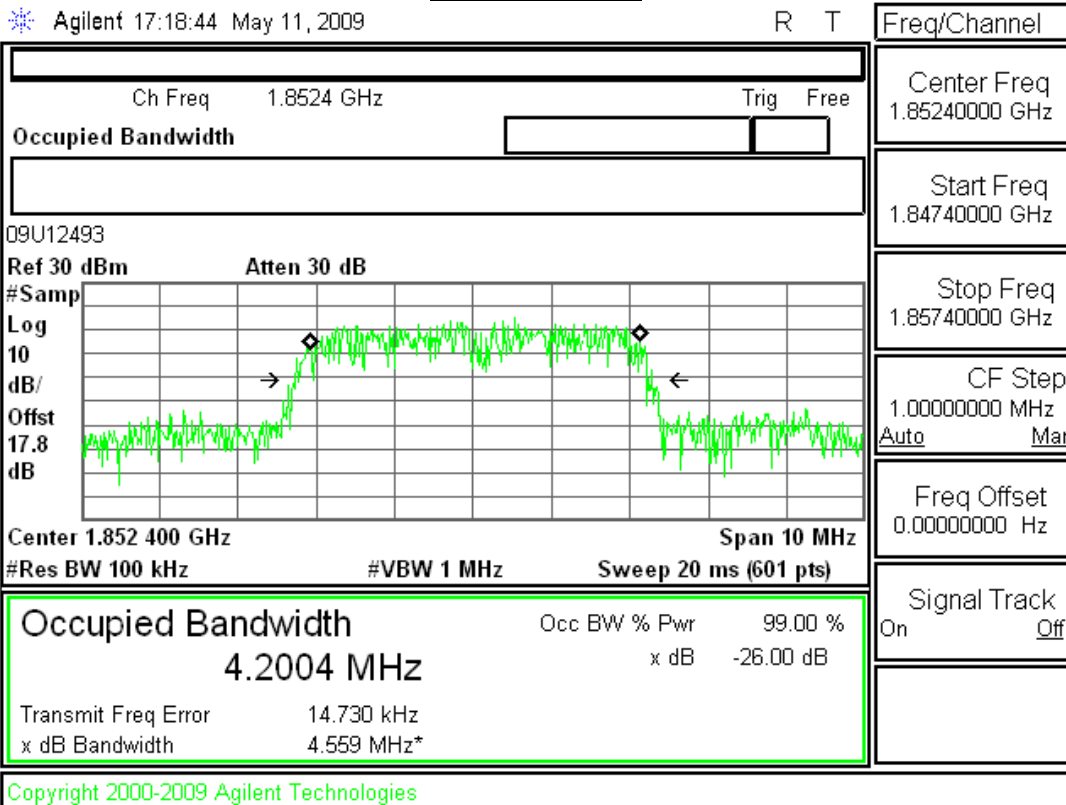

Rel 99, Ch 9400

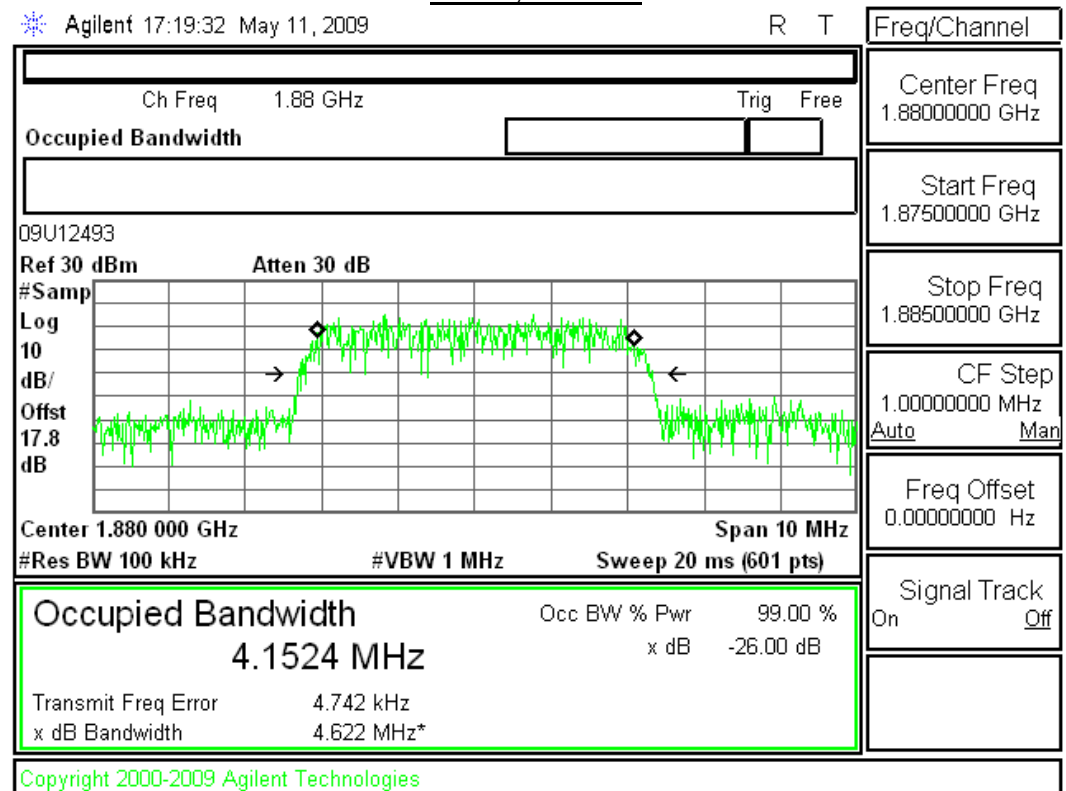

Rel 99, Ch 9538

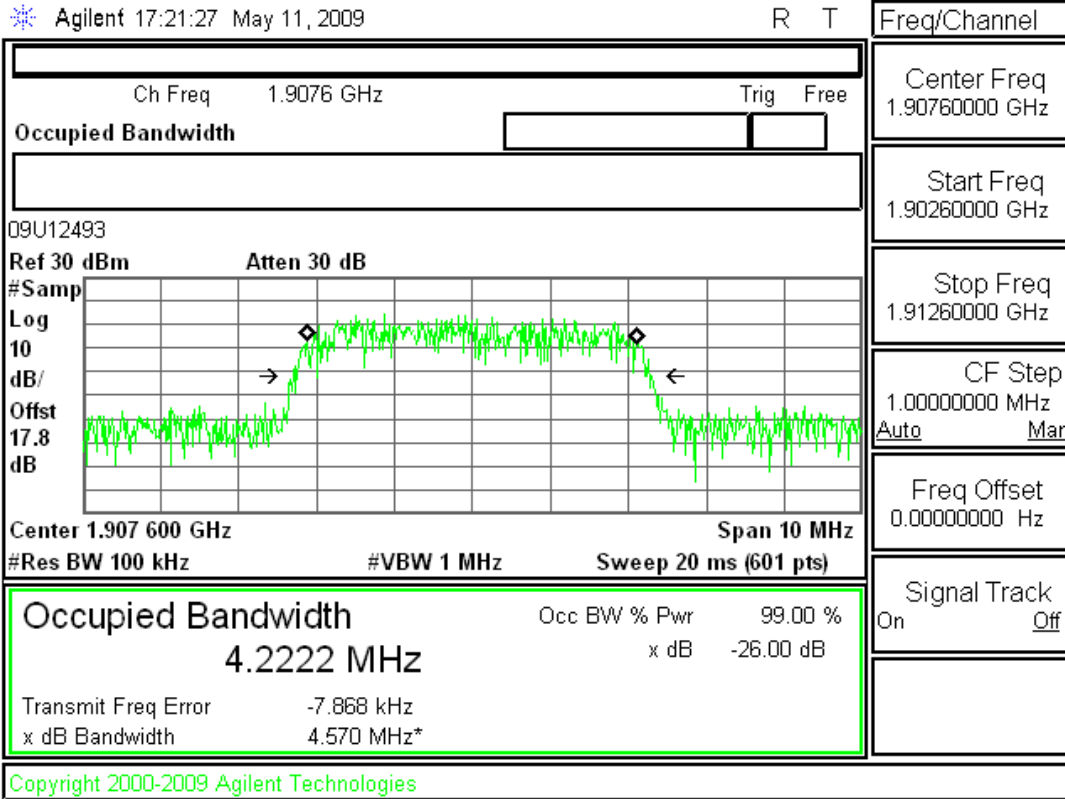

**UMTS Rel 6 HSDPA Subtest 2 Mode (PCS Band)**

**Rel 6 HSDPA Subtest 2, Ch 9262**

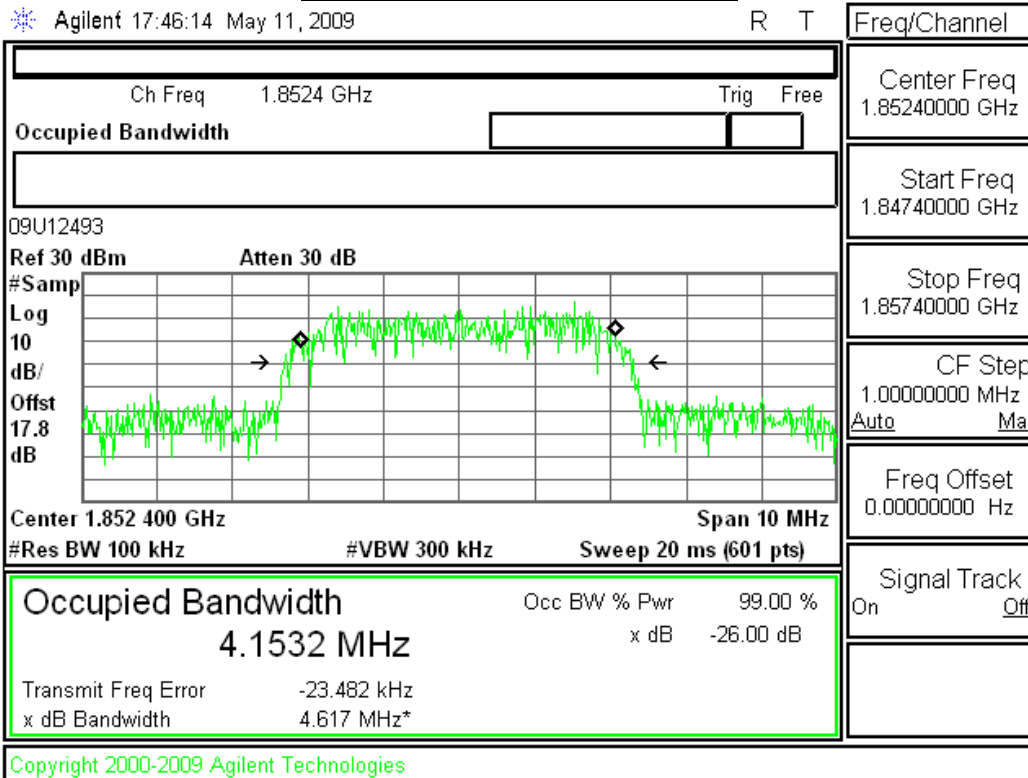

**Rel 6 HSDPA Subtest 2, Ch 9400**

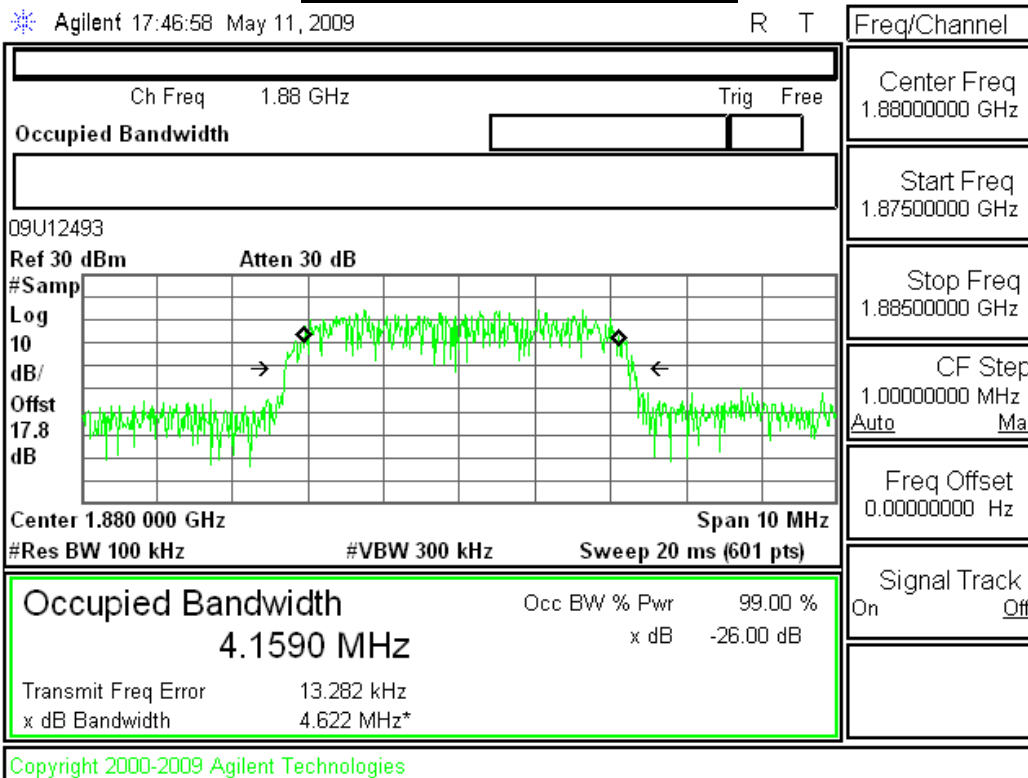



Rel 6 HSDPA Subtest 2, Ch 9538

Agilent 17:47:45 May 11, 2009

R T

Ch Freq 1.9076 GHz		Trig	Free
<b>Occupied Bandwidth</b>			
09U12493			
Ref 30 dBm		Atten 30 dB	
#Samp			
Log			
10			
dB/			
Offst			
17.8			
dB			
Center 1.907 600 GHz		Span 10 MHz	
#Res BW 100 kHz	#VBW 300 kHz	Sweep 20 ms (601 pts)	
<b>Occupied Bandwidth</b>		Occ BW % Pwr	99.00 %
4.1371 MHz		x dB	-26.00 dB
Transmit Freq Error		13.404 kHz	
x dB Bandwidth		4.566 MHz*	
Copyright 2000-2009 Agilent Technologies			

Freq/Channel
Center Freq 1.90760000 GHz
Start Freq 1.90260000 GHz
Stop Freq 1.91260000 GHz
CF Step 1.00000000 MHz
Auto Man
Freq Offset 0.00000000 Hz
Signal Track On Off

## **11.2. BAND EDGE**

### **RULE PART(S)**

FCC: §22.359, 24.238

IC: RSS-132, 4.5; RSS-133, 6.5

### **LIMITS**

The power of any emission outside of the authorized operating frequency ranges must be attenuated below the transmitting power (P) by a factor of at least  $43 + 10 \log (P)$  dB.

### **TEST PROCEDURE**

The transmitter output was connected to a Agilent 8960 Test Set and configured to operate at maximum power. The band edge emissions were measured at the required operating frequencies in each band on the Spectrum Analyzer.

For each band edge measurement:

- Set the spectrum analyzer span to include the block edge frequency (824, 848, 1850, 1910MHz)
- Set a marker to point the corresponding band edge frequency in each test case.
- Set display line at -13 dBm
- Set resolution bandwidth to at least 1% of emission bandwidth.

### **MODES TESTED**

- GSM, EGPRS, Rel 99 & HSDPA Rel 6 Subtest 2.

### **RESULTS**

See the following pages.

**GPRS mode (Cellular Band)**

**GPRS, Ch 128 (824 MHz)**

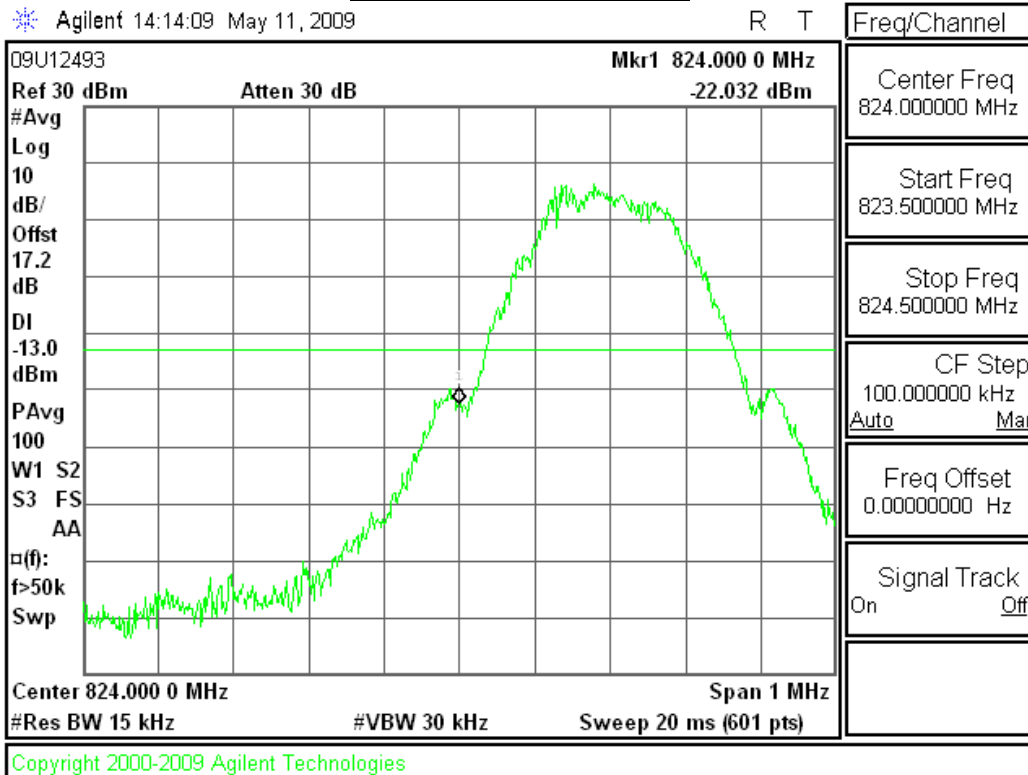

**GPRS, Ch 251 (849 MHz)**

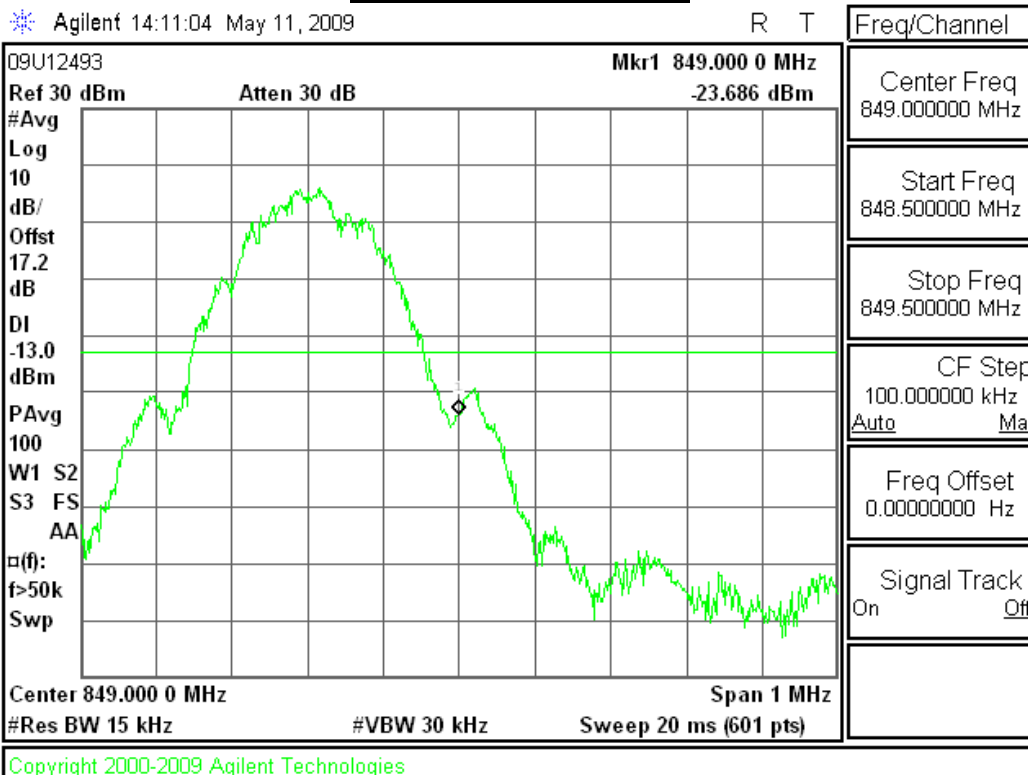

**EGPRS mode (Cellular Band)**

**EGPRS, Ch 128 (824 MHz)**

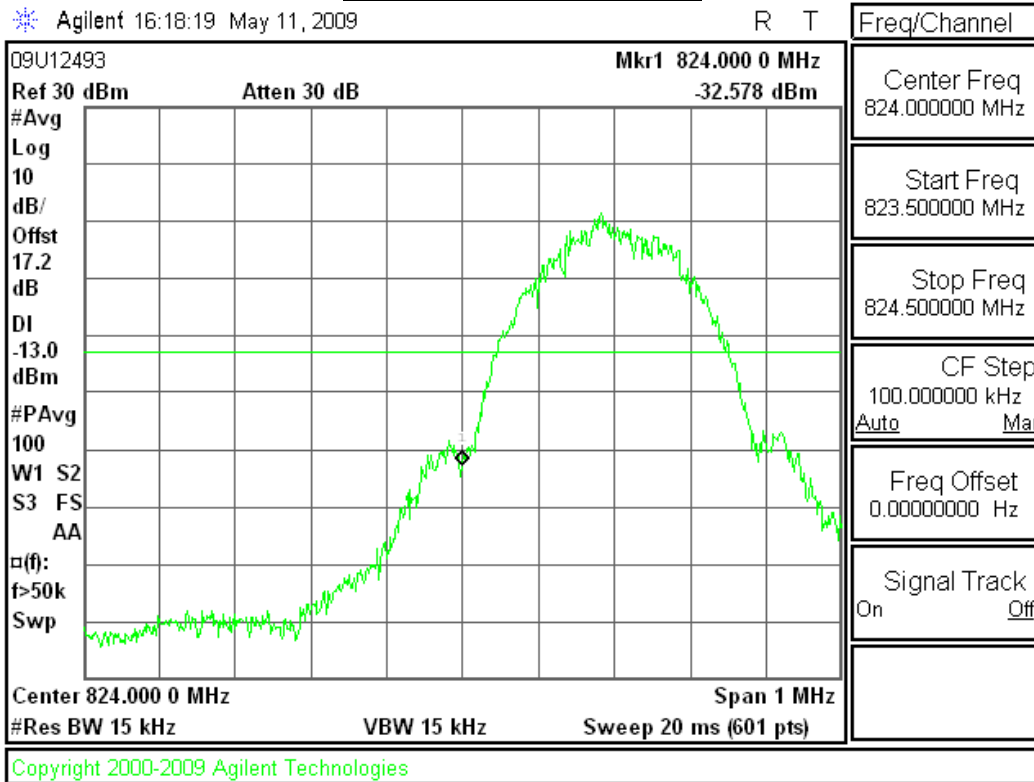

**EGPRS, Ch 251 (849 MHz)**

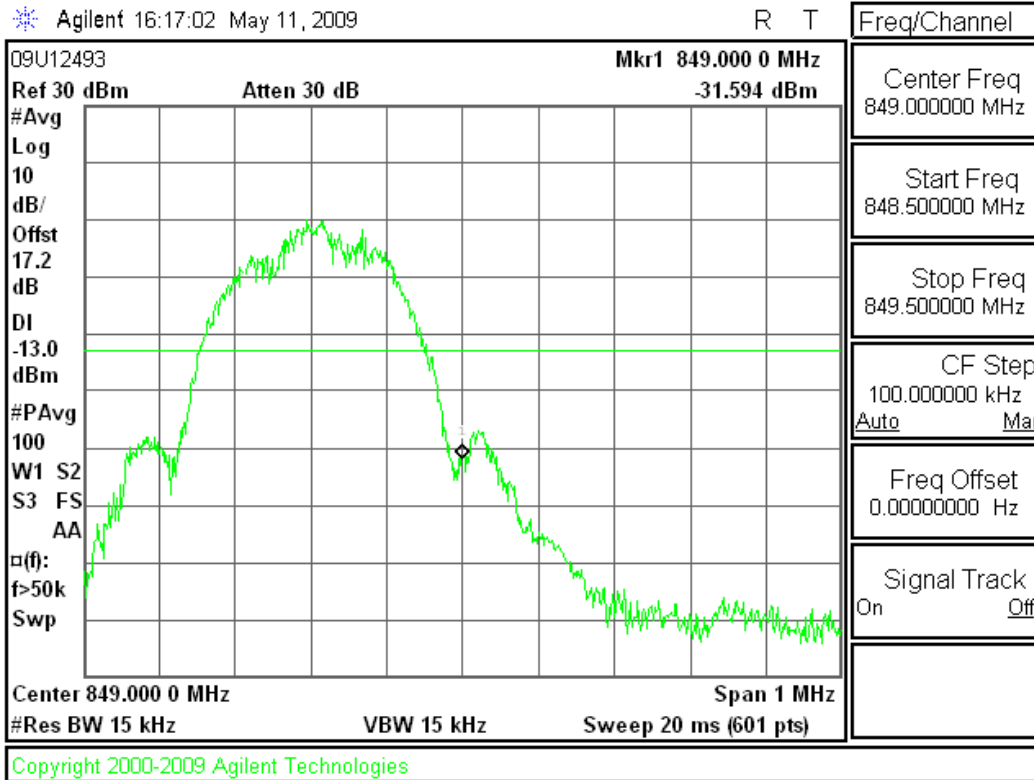

**UMTS Rel 99 mode (Cellular Band)**

**Rel 99, Ch 4132 (824 MHz)**

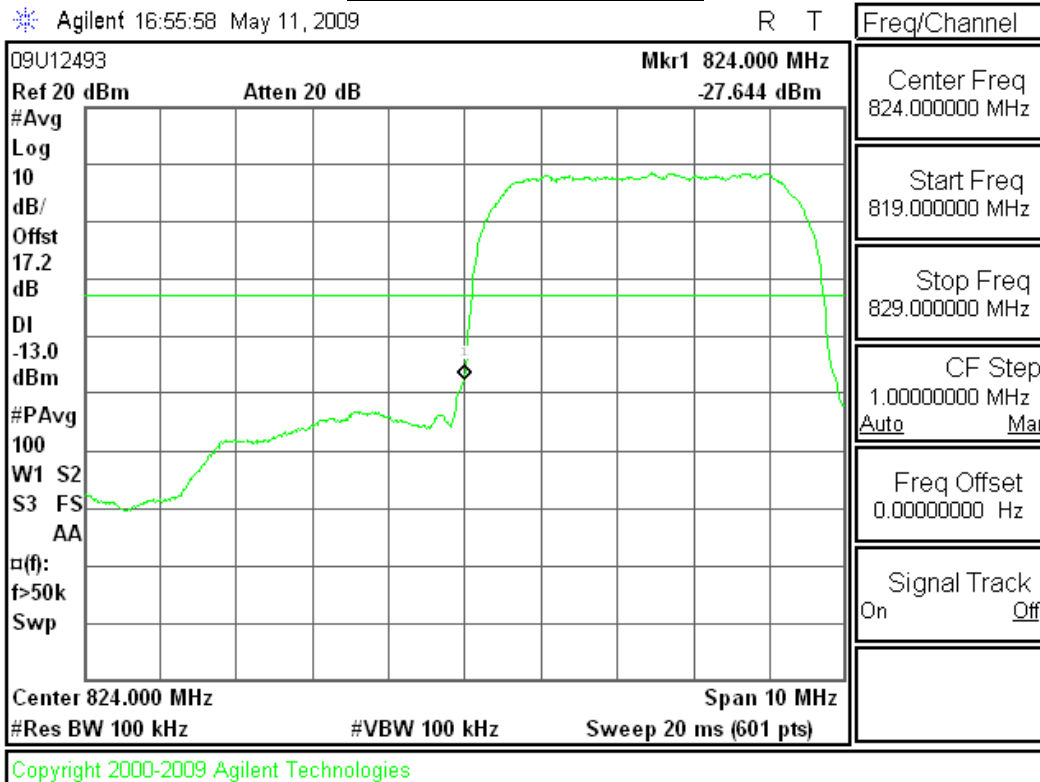

**Rel 99, Ch 4230 (849 MHz)**

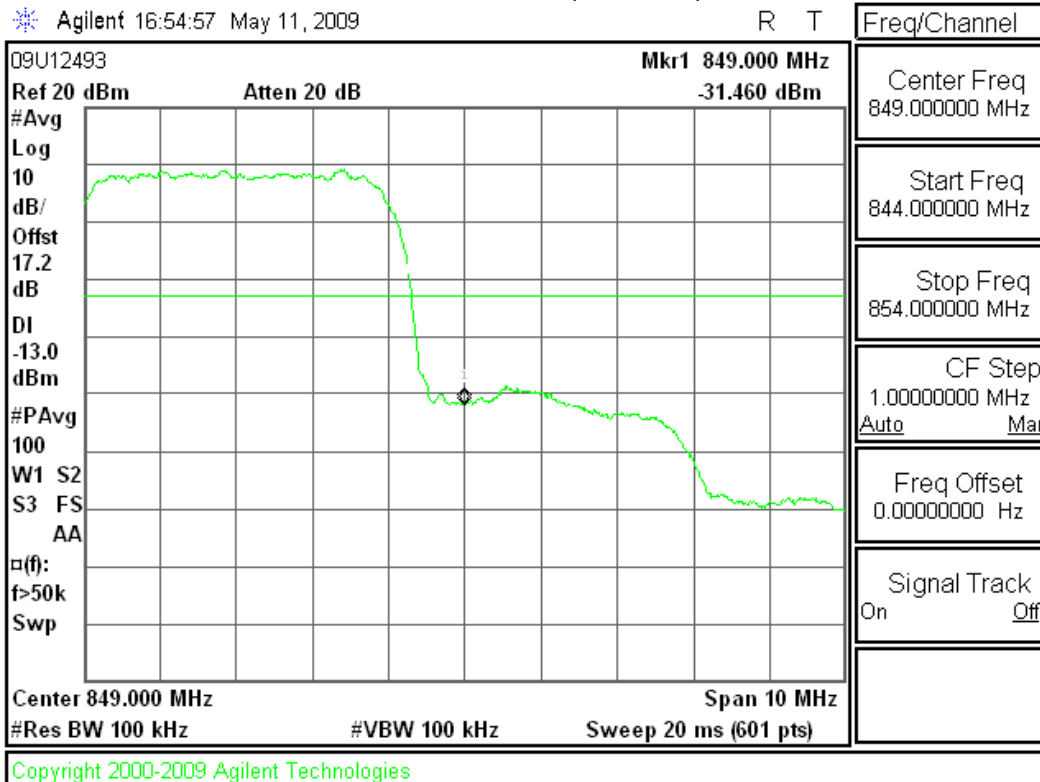

**UMTS Rel 6 HSDPA mode (Cellular Band)**

**Rel 6 HSDPA Subtest 2, Ch 4132 (824 MHz)**

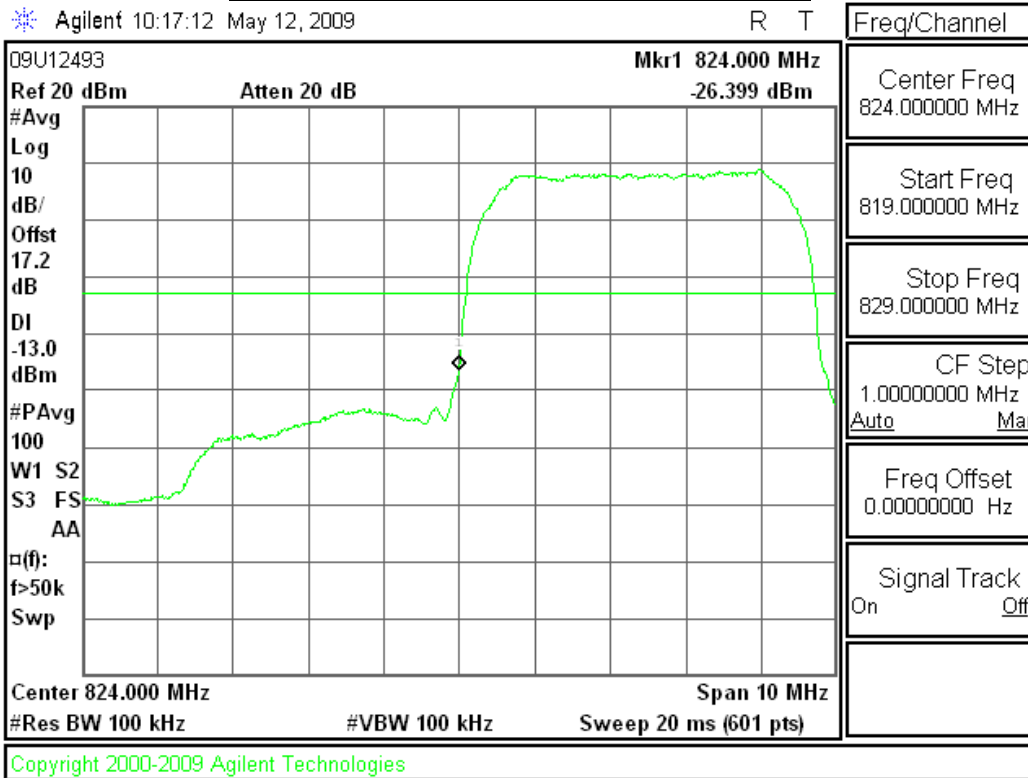

**Rel 6 HSDPA Subtest 2, Ch 4230 (849 MHz)**

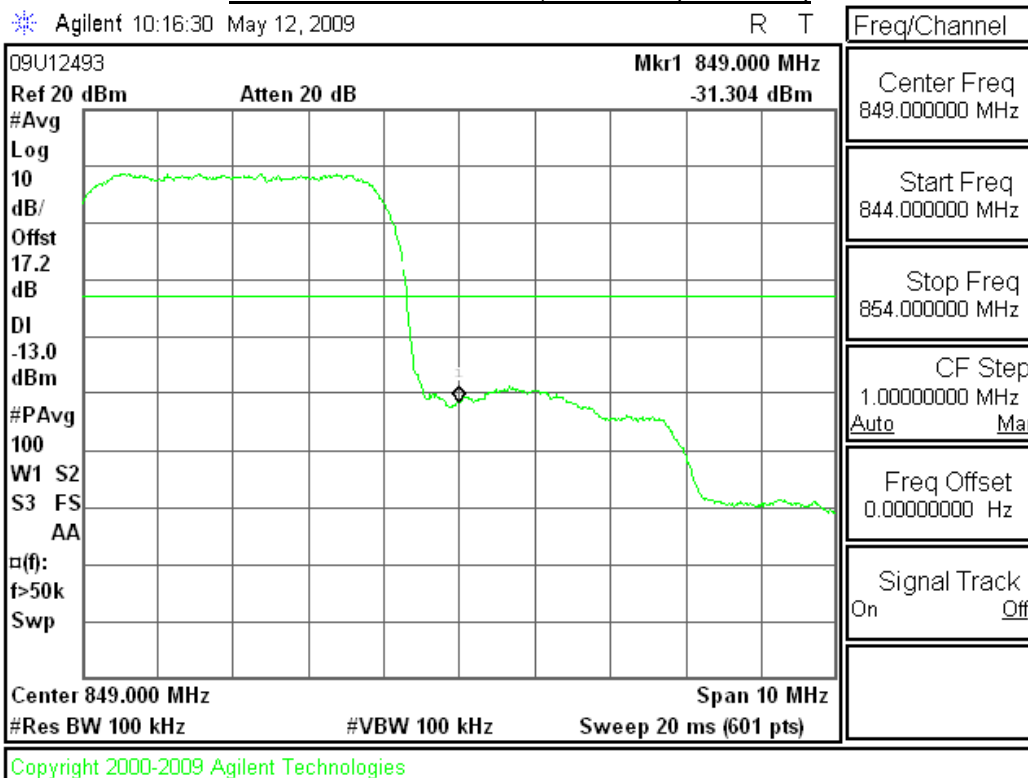

**GPRS mode (PCS Band)**

**GPRS, Ch 512 (1850 MHz)**

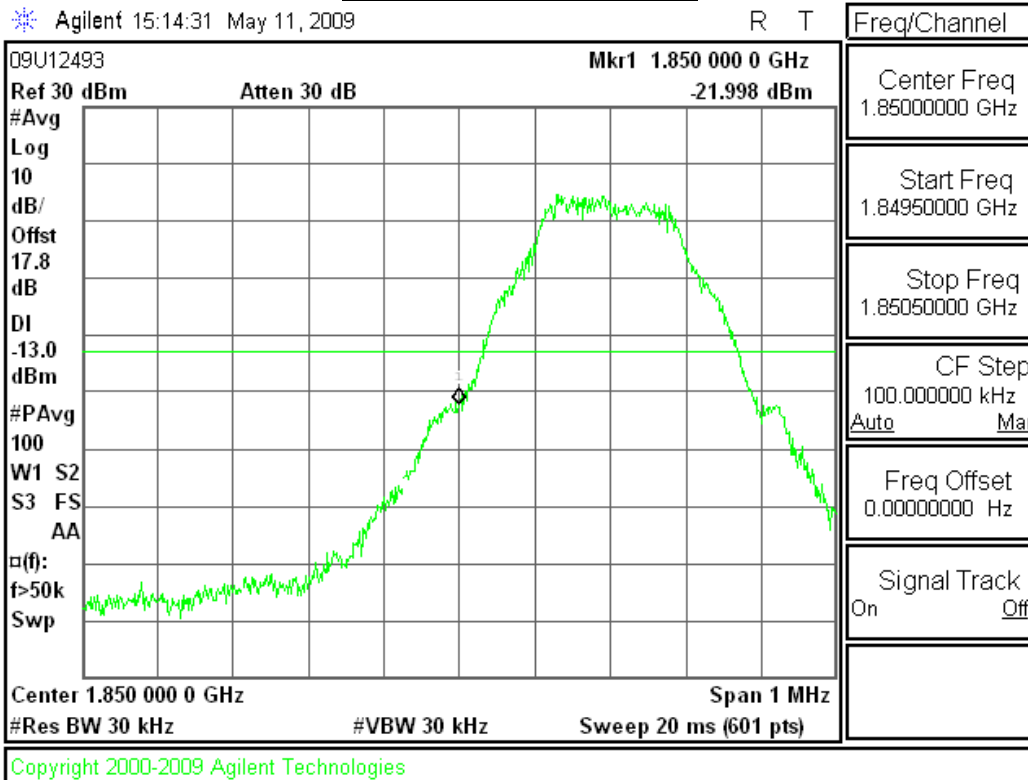

**GPRS, Ch 810 (1910 MHz)**

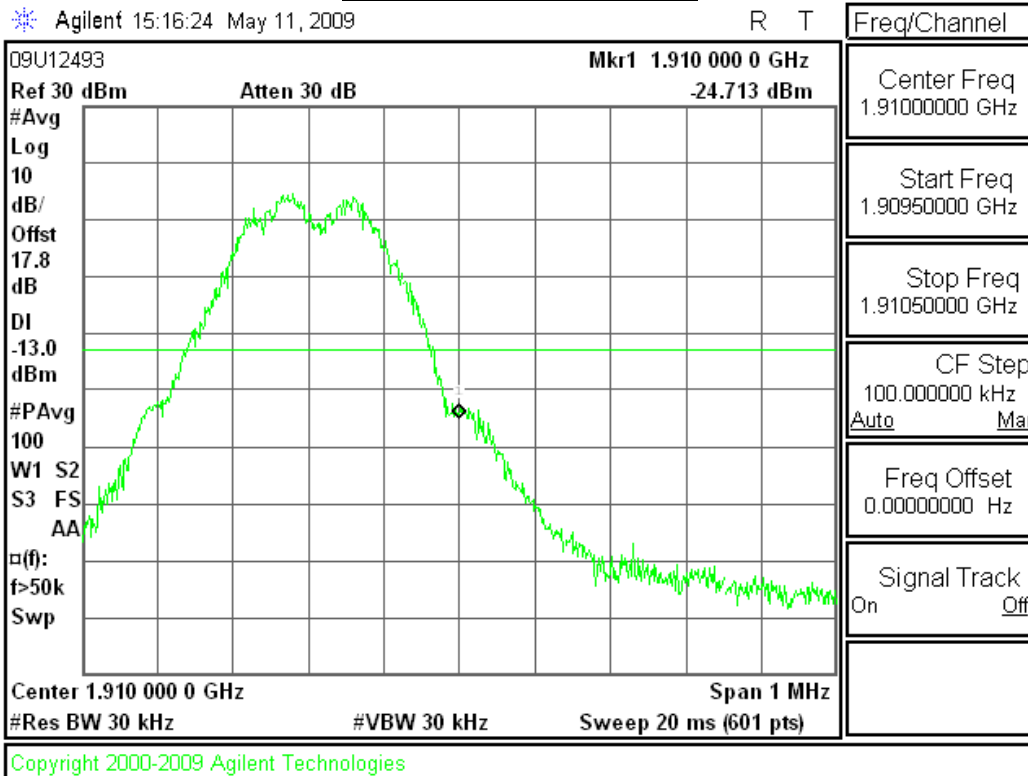

**EGPRS mode (PCS Band)**

**EGPRS, Ch 512 (1850 MHz)**

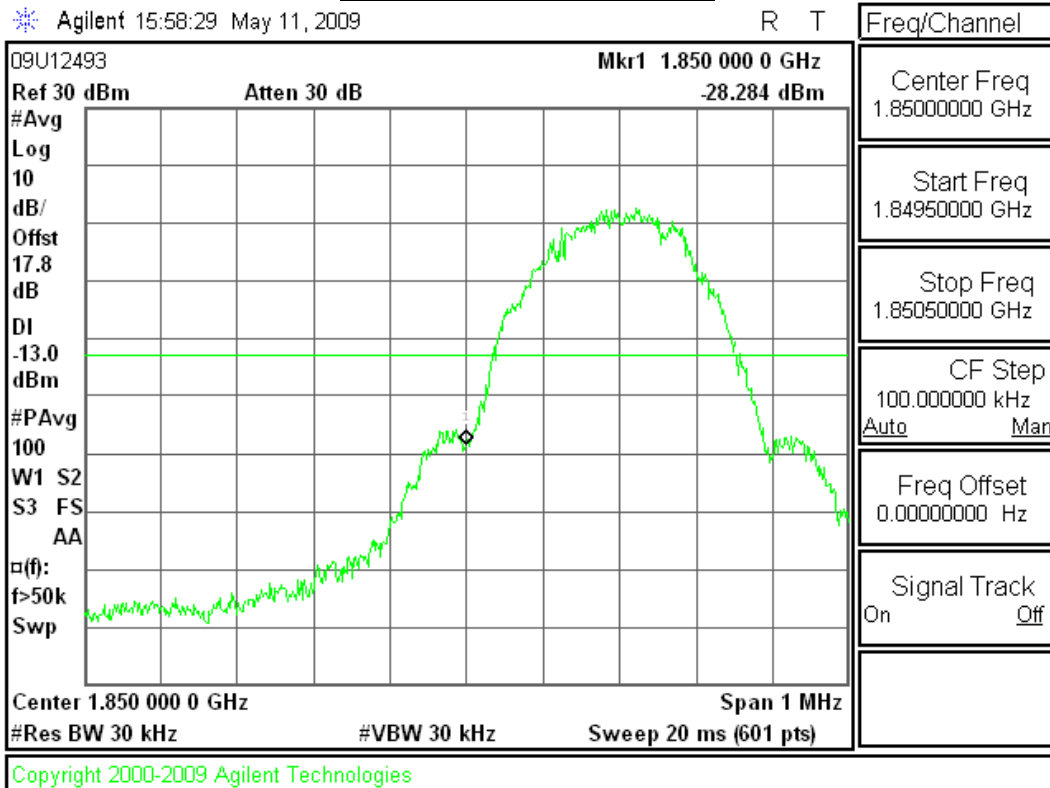

**EGPRS, Ch 810 (1910 MHz)**

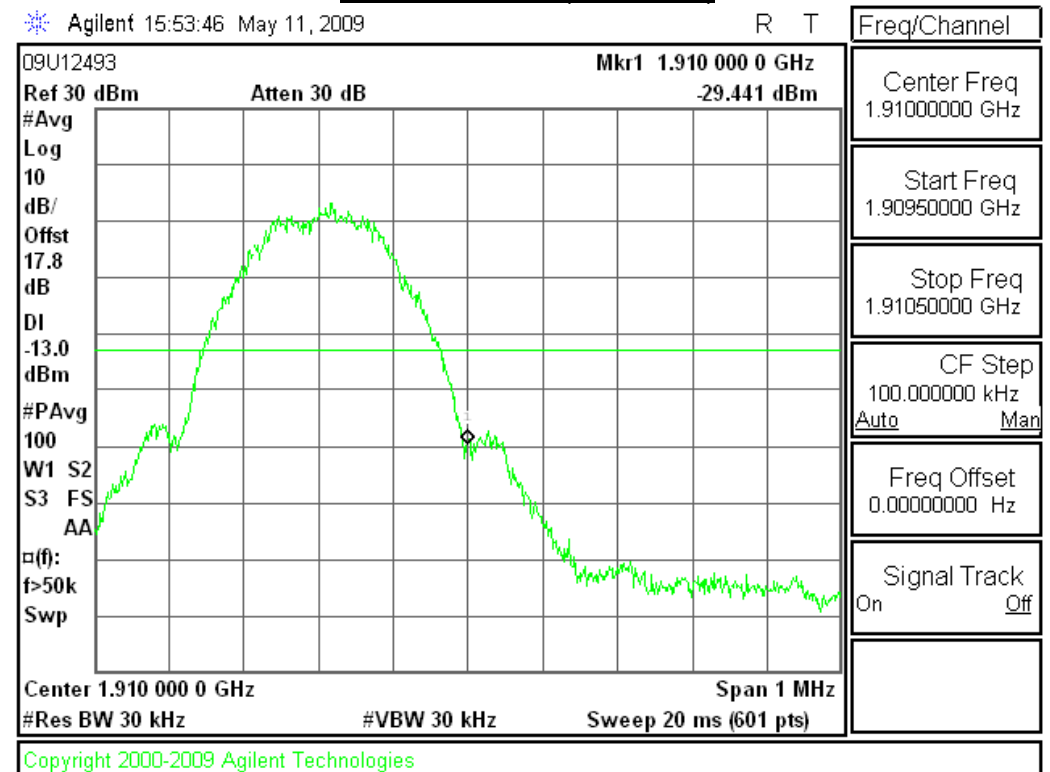



**UMTS Rel 99 mode (PCS Band)**

**Rel 99, Ch 962 (1850 MHz)**

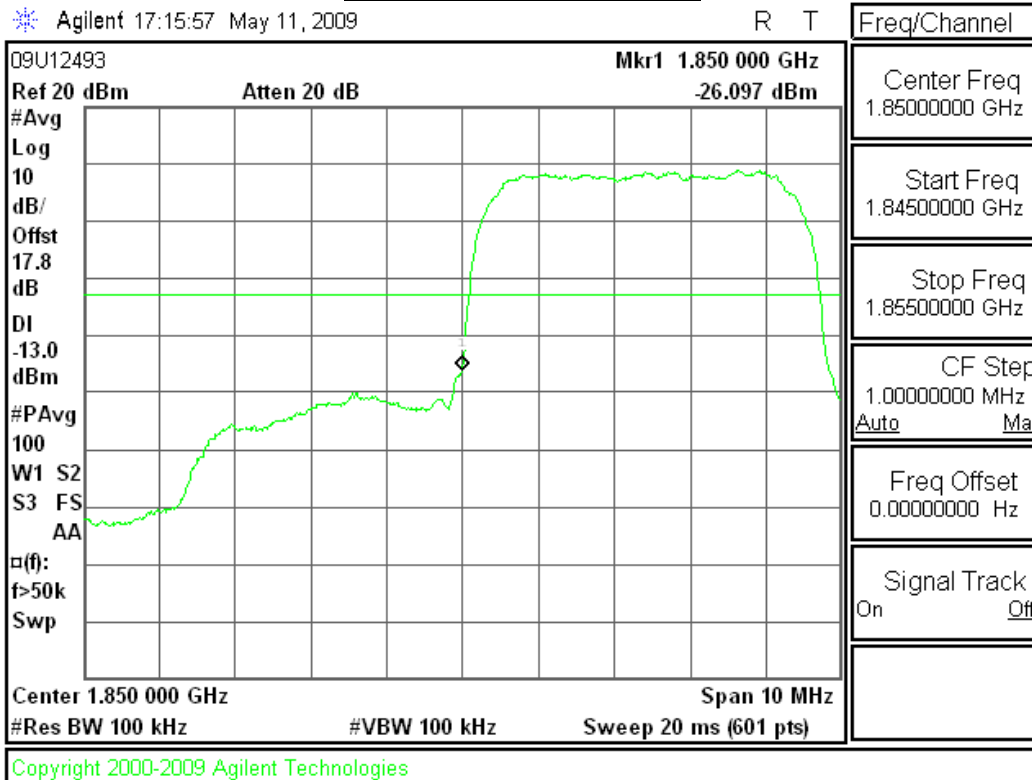

**Rel 99, Ch 9538 (1910 MHz)**

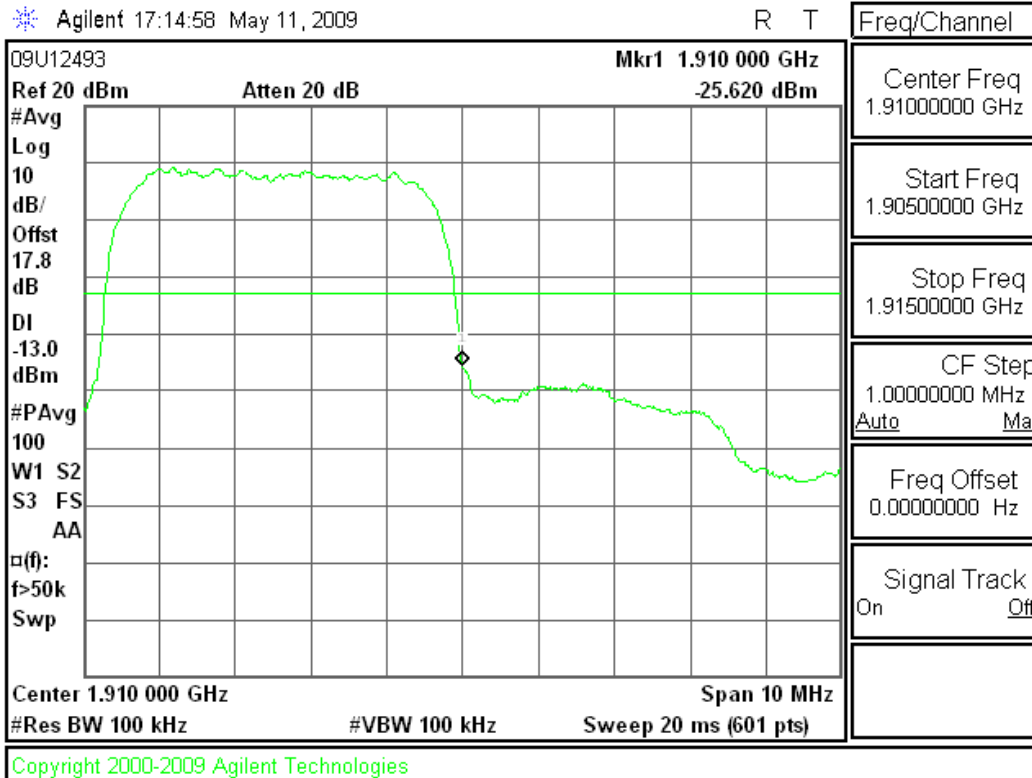

**UMTS Rel 6 HSDPA mode (PCS Band)**

**Rel 6 HSDPA Subtest 2, Ch 9262 (1850 MHz)**

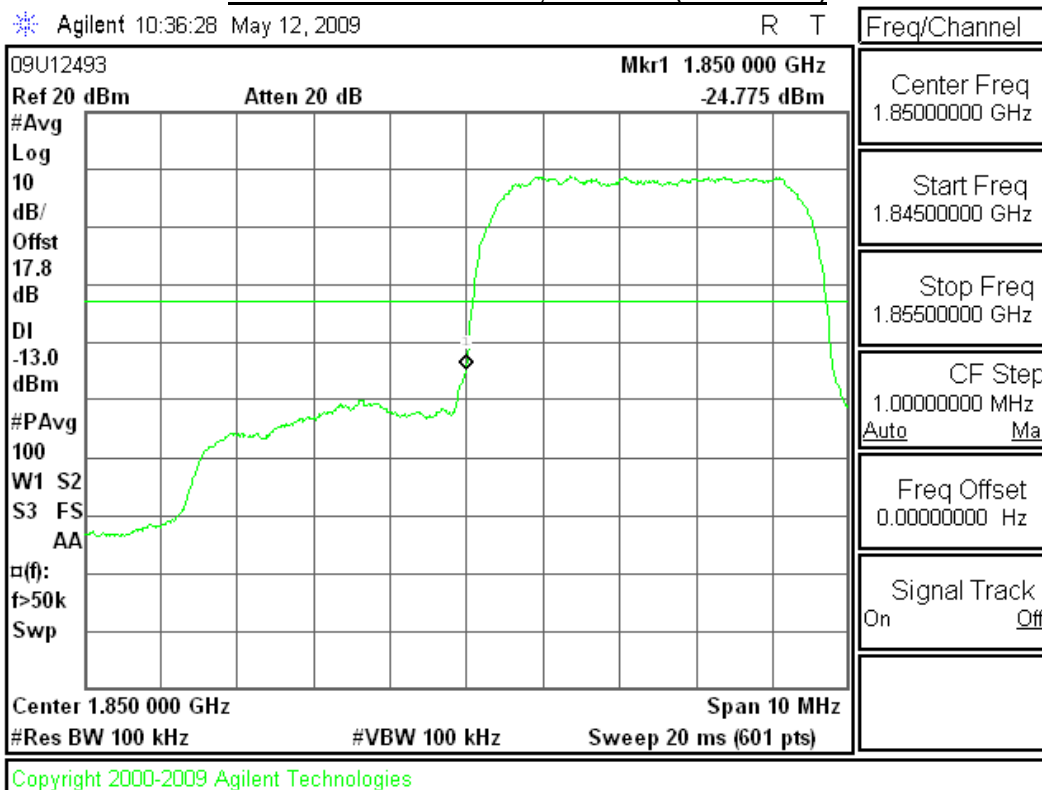

**Rel 6 HSDPA Subtest 2, Ch 9538 (1910 MHz)**

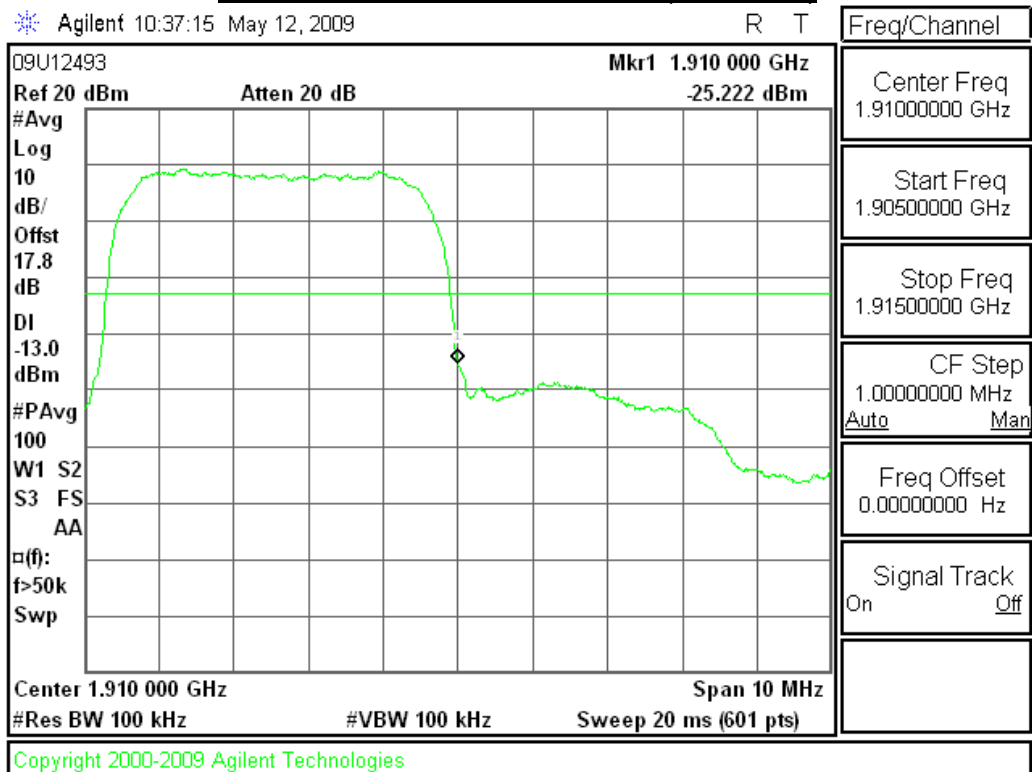

### **11.3. OUT OF BAND EMISSIONS**

#### **RULE PART(S)**

FCC: §2.1051, §22.901, §22.917, §24.238  
IC: RSS-132, 4.5; RSS-133, 6.5

#### **LIMITS**

The power of any emission outside of the authorized operating frequency ranges must be attenuated below the transmitting power (P) by a factor of at least  $43 + 10 \log (P)$  dB.

#### **TEST PROCEDURE**

The RF output of the transmitter was connected to a spectrum analyzer through a calibrated coaxial cable. Sufficient scans were taken to show the out-of-band Emissions, if any, up to 10th harmonic. Multiple sweeps were recorded in maximum hold mode using a peak detector to ensure that the worst-case emissions were caught.

For each out of band emissions measurement:

- Set display line at -13 dBm
- Set RBW & VBW to 100 kHz for the measurement below 1 GHz, and 1 MHz for the measurement above 1 GHz.

#### **MODES TESTED**

- GSM, EGPRS, Rel 99 & HSDPA Rel 6 Subtest 2.

#### **RESULTS**

See the following pages.

**GPRS Mode (Cellular Band)**

GPRS, Ch 128

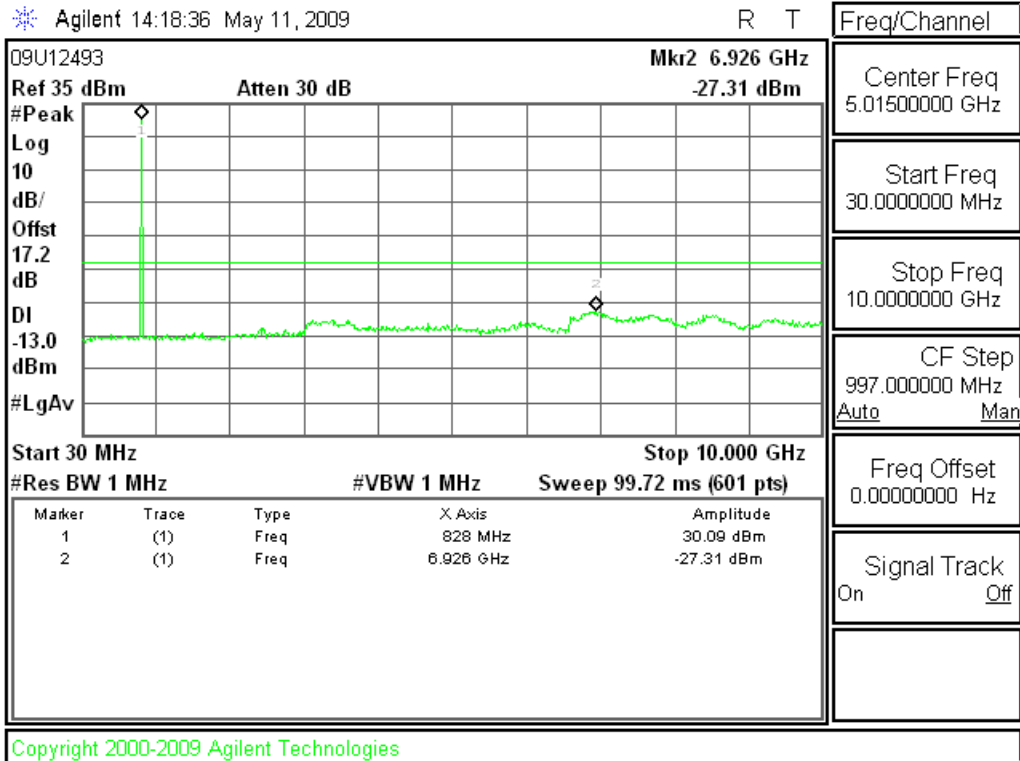

GPRS, Ch 190

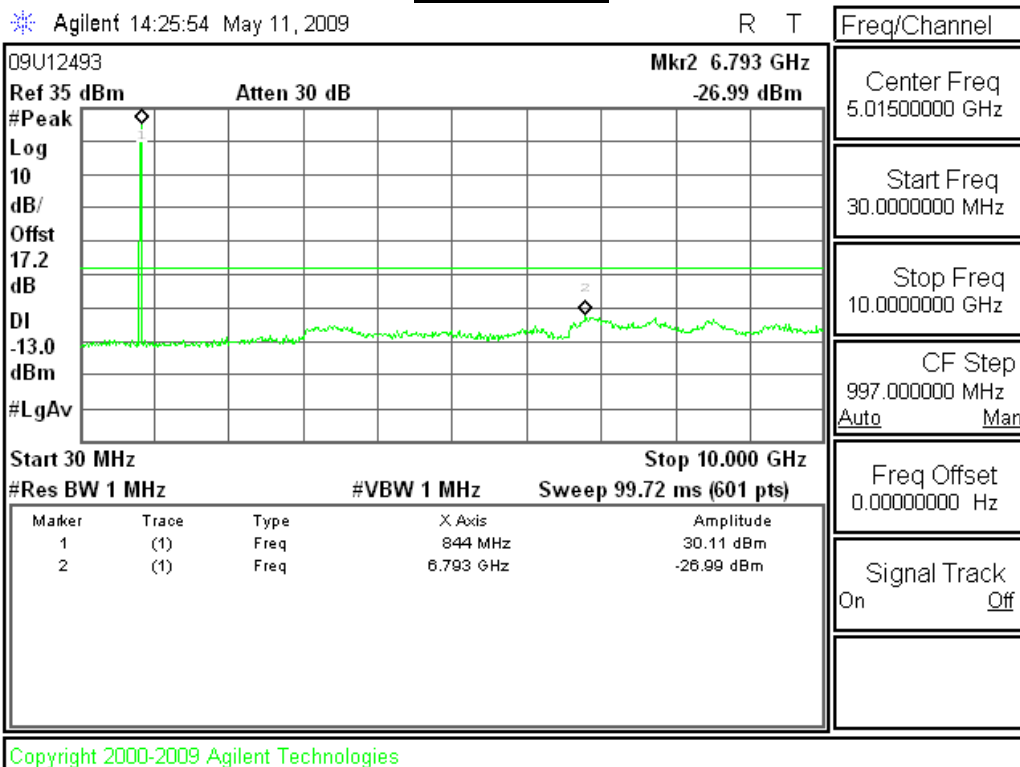

**GPRS, Ch 251**

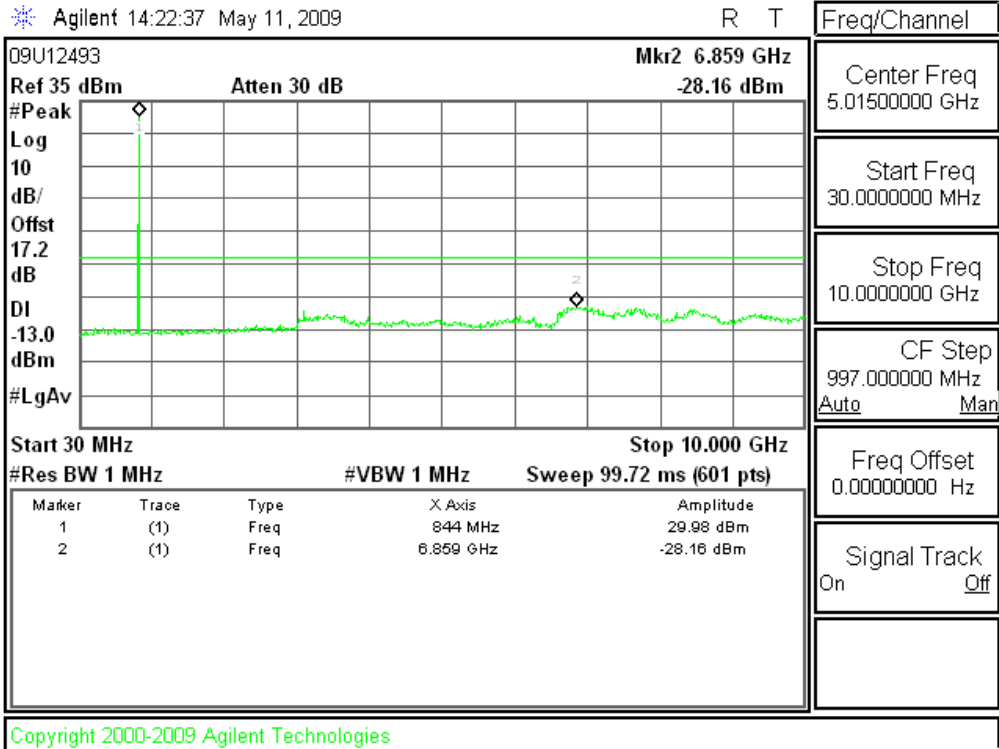

**EGPRS Mode (Cellular Band)**

EGPRS, Ch 128

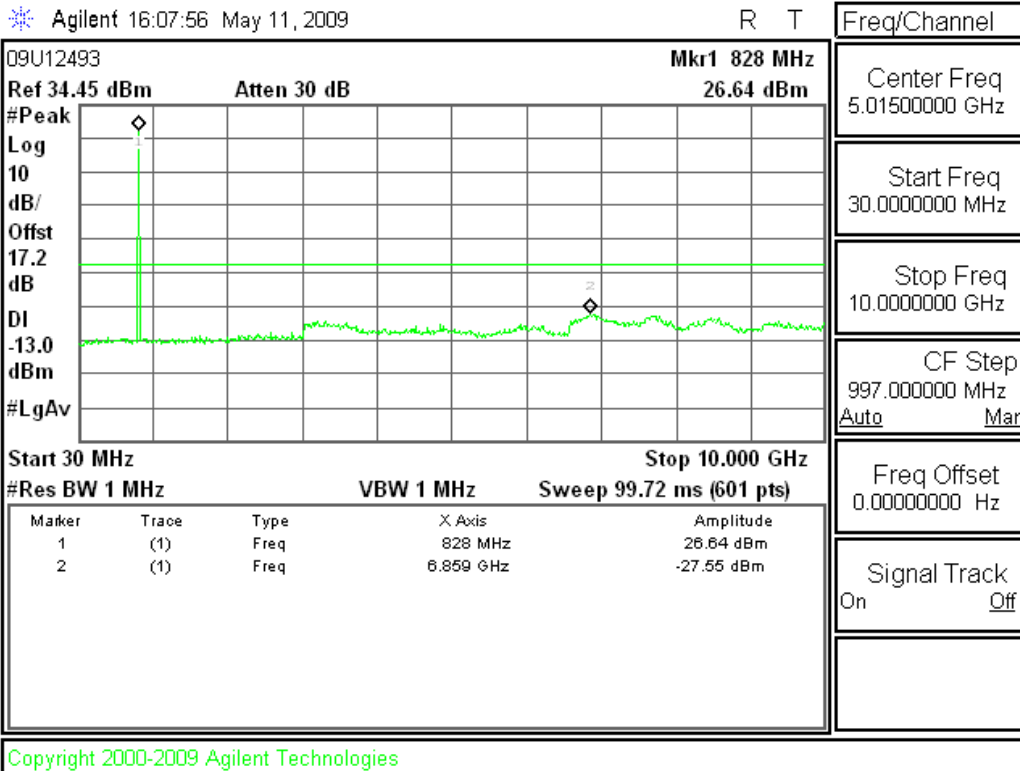

EGPRS, Ch 190

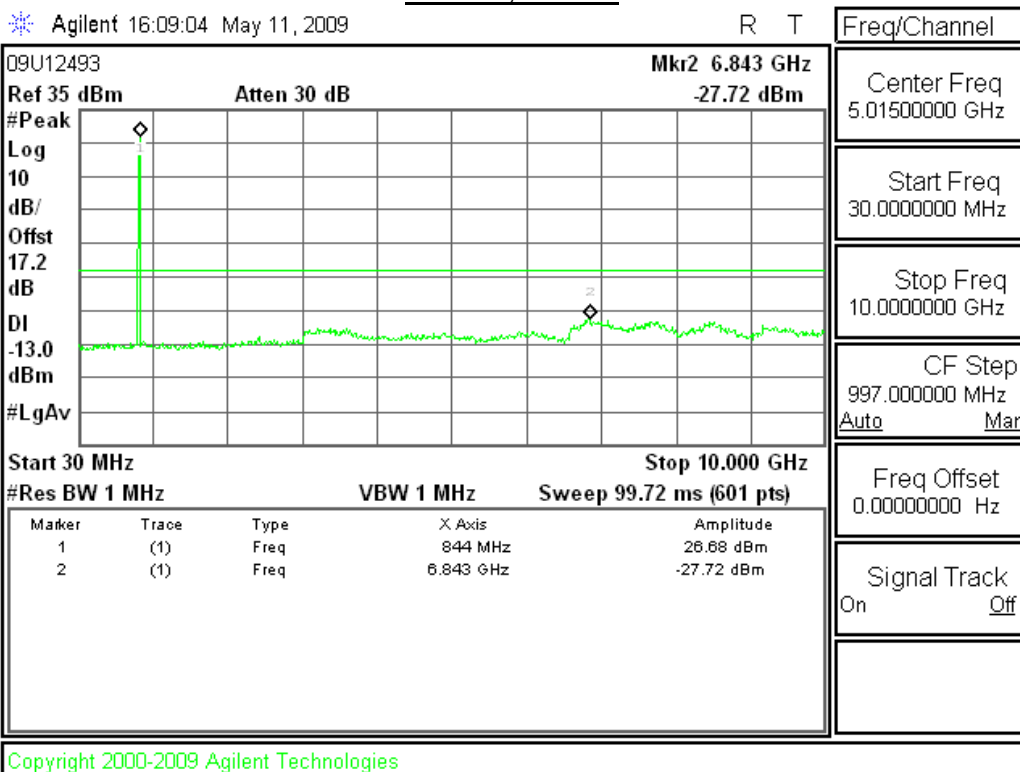

EGPRS, Ch 251

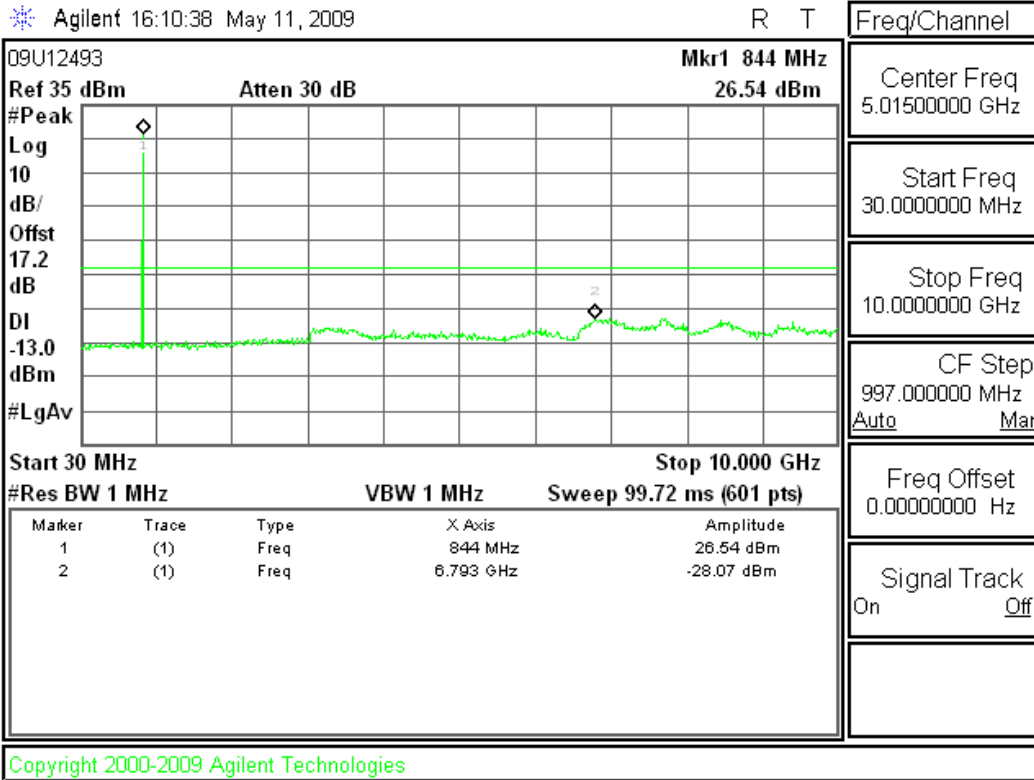

**Plots for UMTS Rel 99 Mode (Cellular Band)**

UMTS Rel 99, Ch 4132

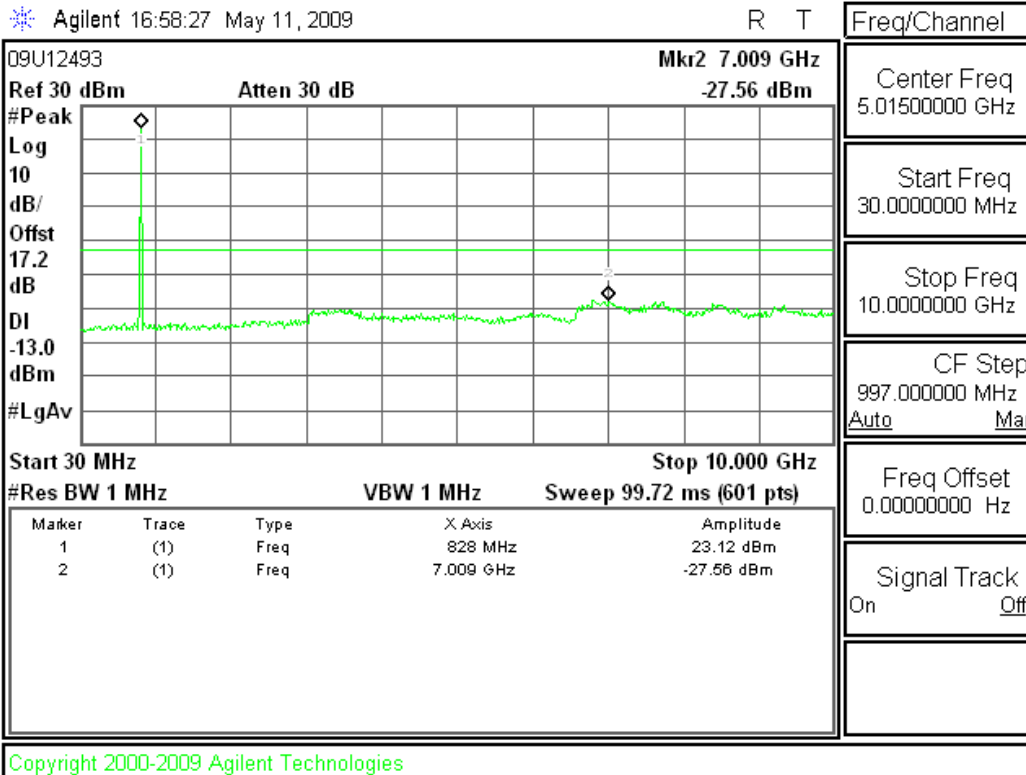

UMTS Rel 99, Ch 4180

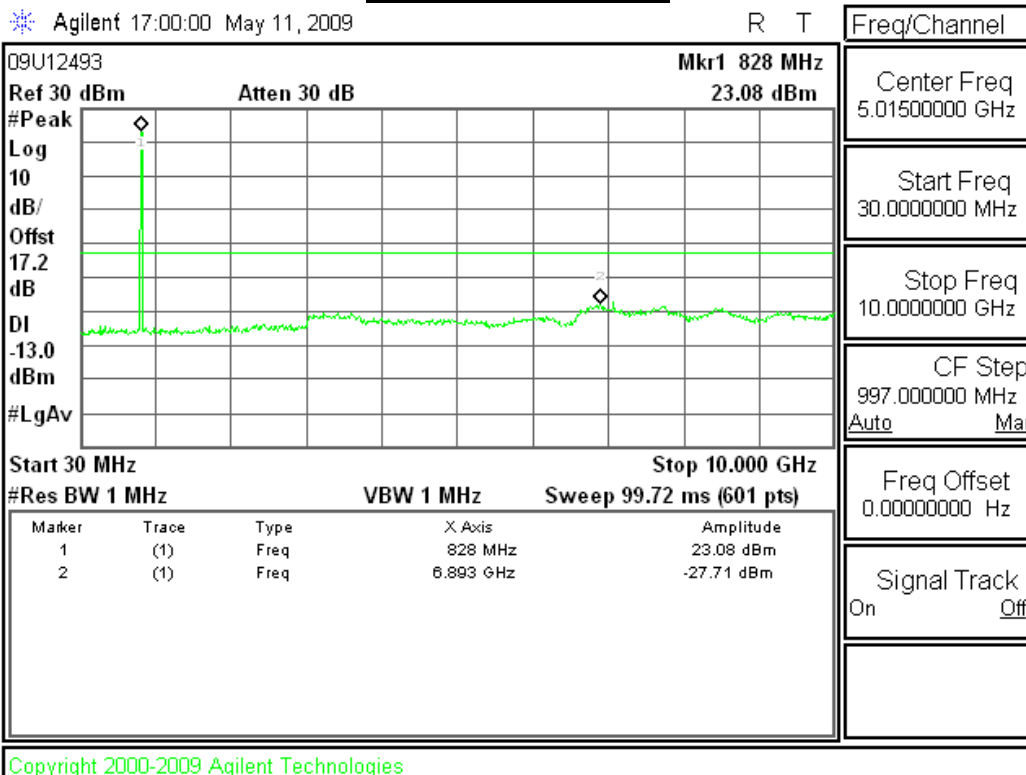



UMTS Rel 99, Ch 4230

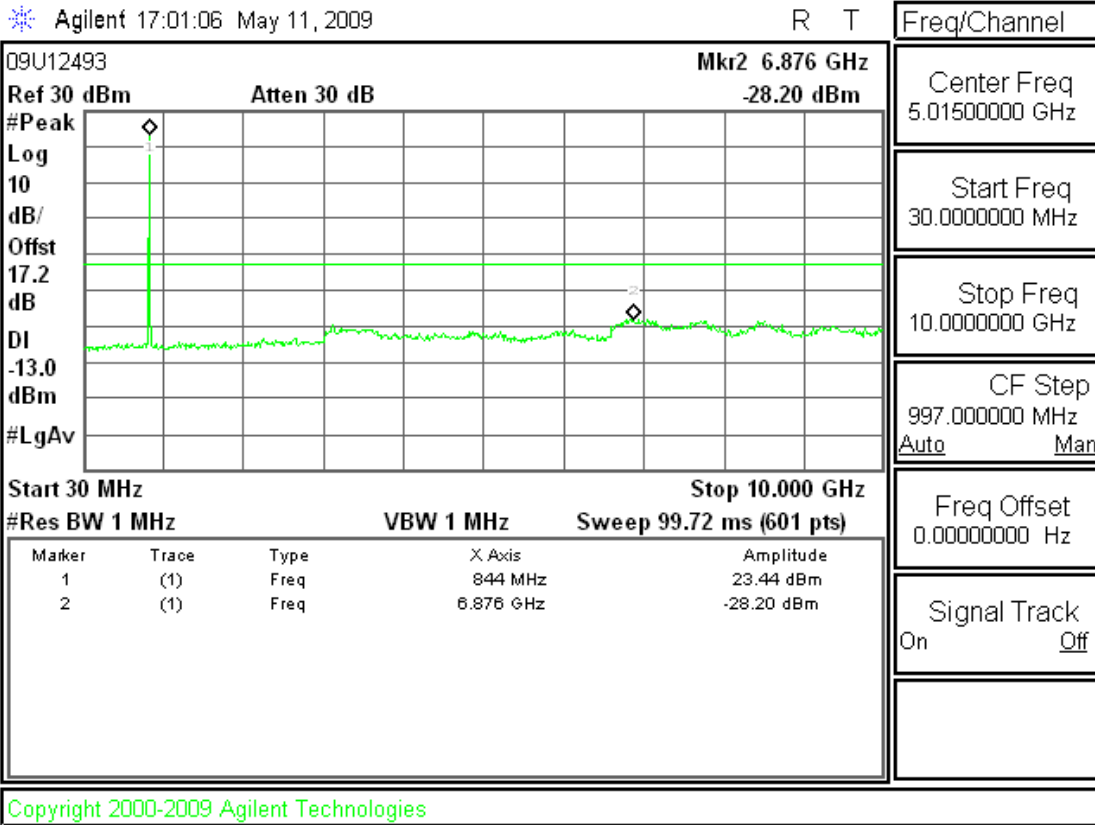

**UMTS Rel 6 HSDPA Subtest 2 Mode (Cellular Band)**

**UMTS Rel 6 HSDPA Subtest 2, Ch 4132**

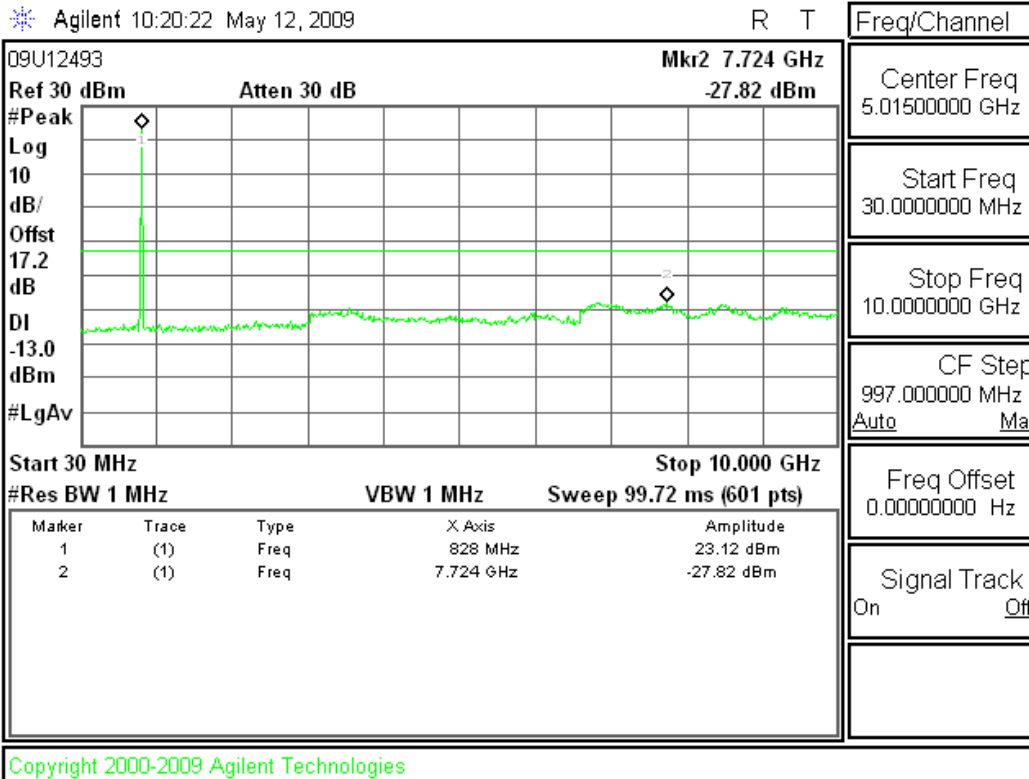

**UMTS Rel 6 HSDPA Subtest 2, Ch 4180**

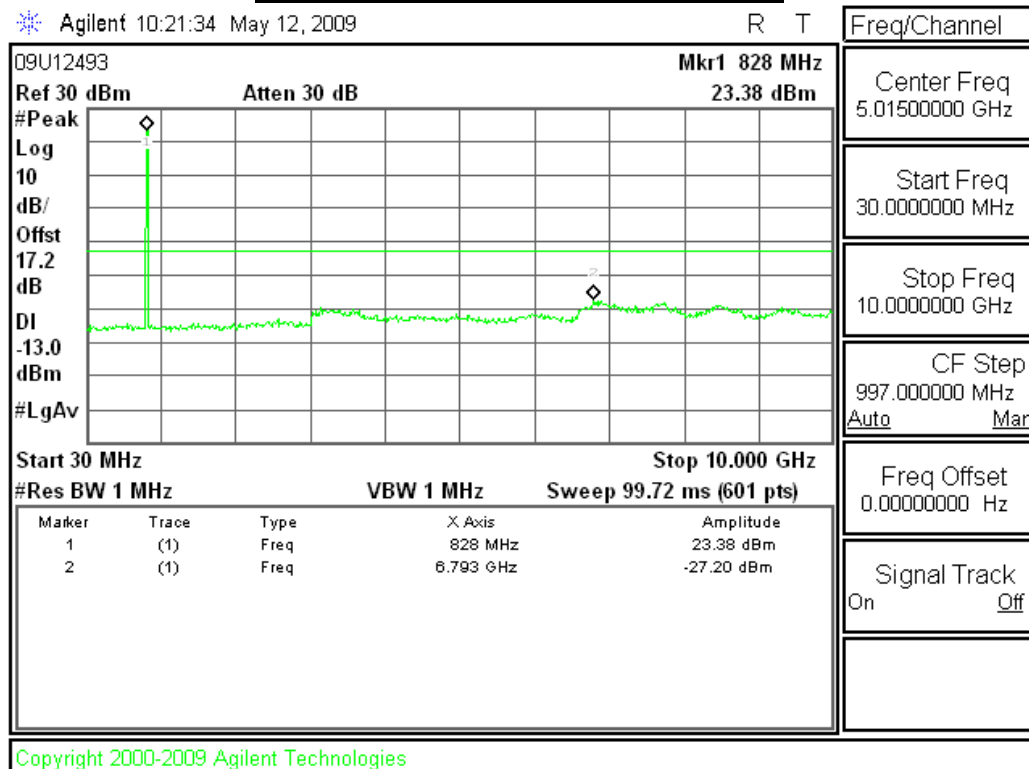

UMTS Rel 6 HSDPA Subtest 2, Ch 4230

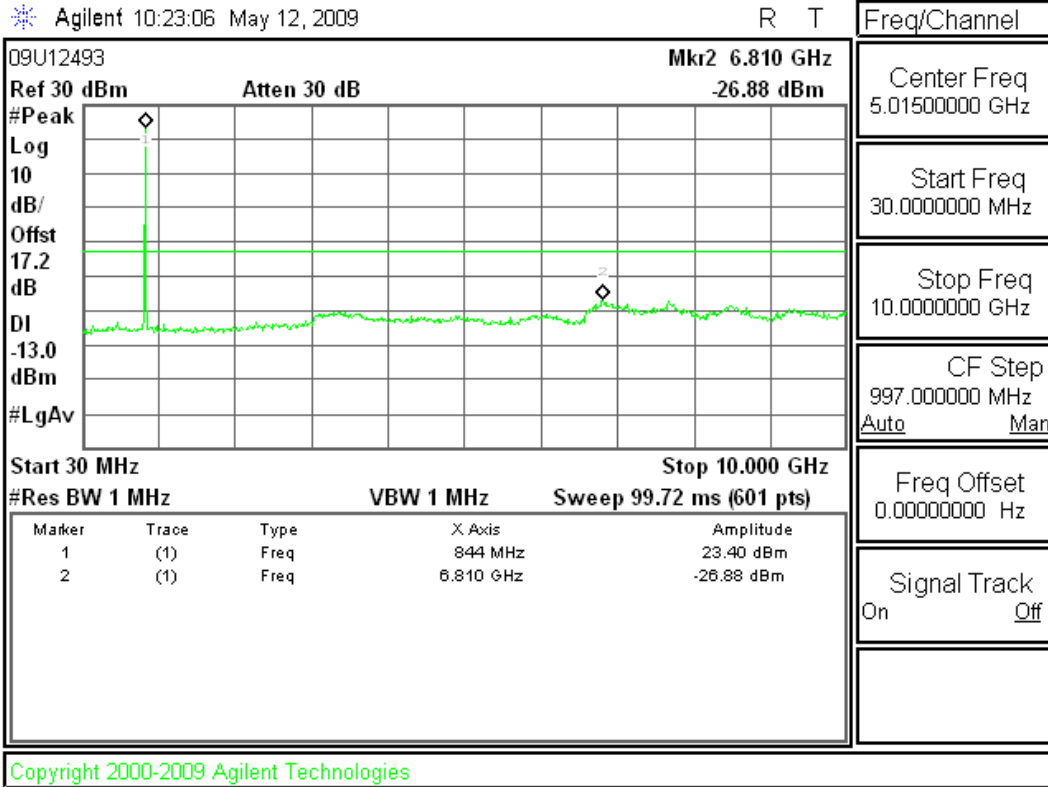

**GPRS Mode (PCS Band)**

GPRS, Ch 512

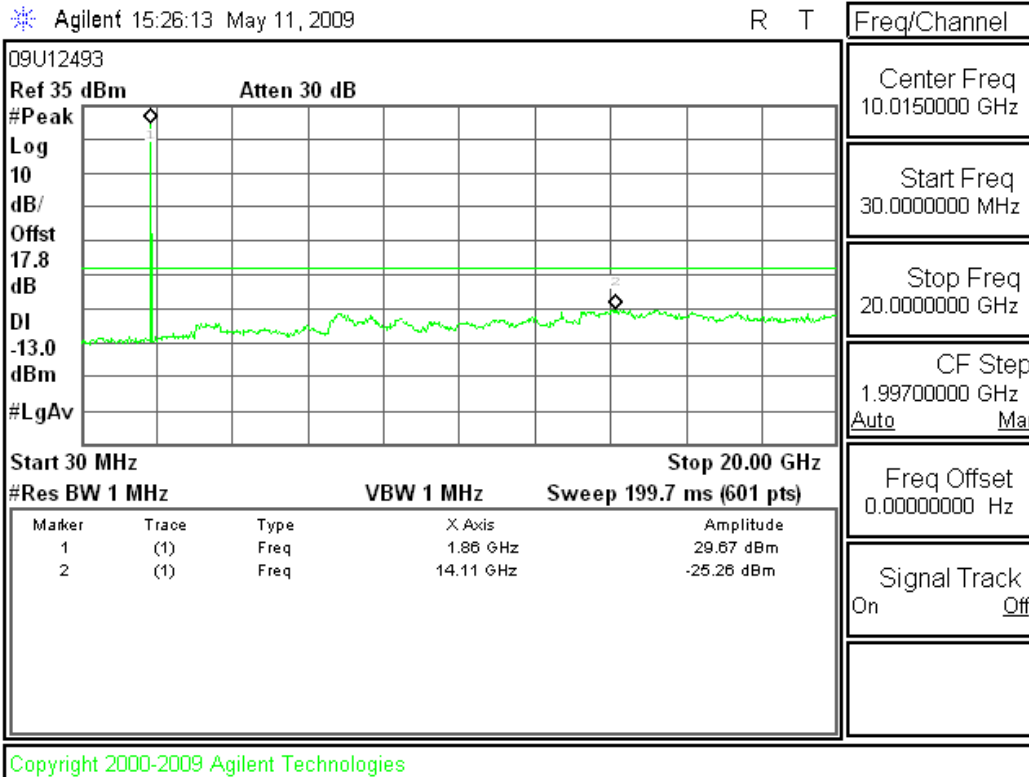

GPRS, Ch 661

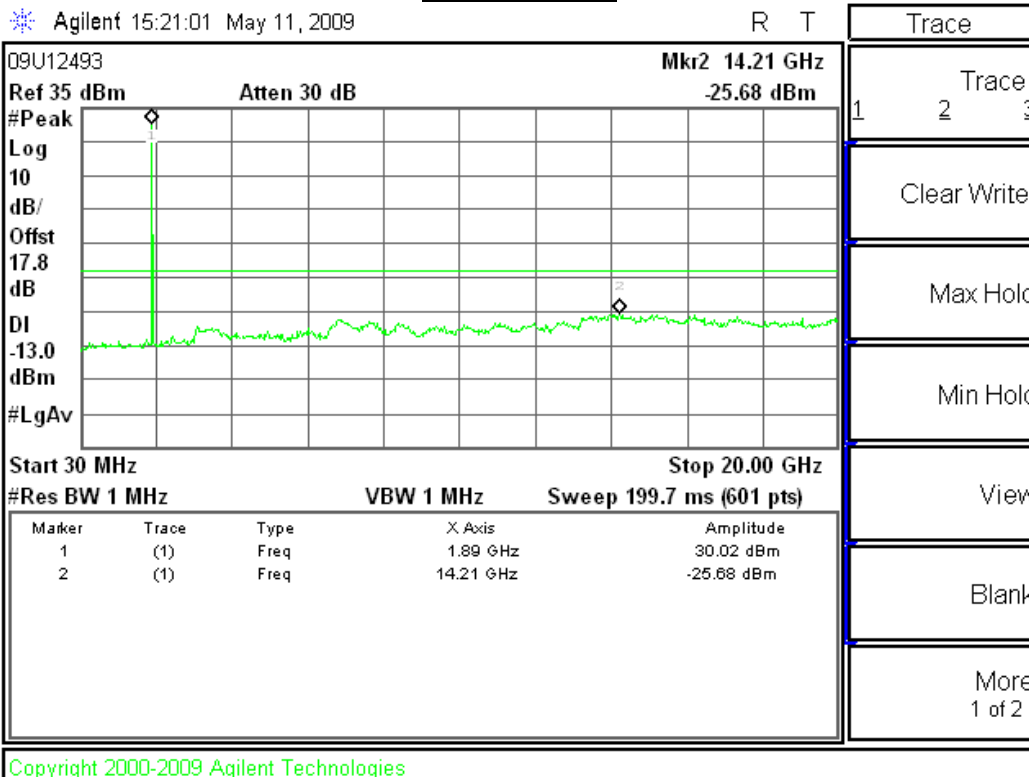

GPRS, Ch 810

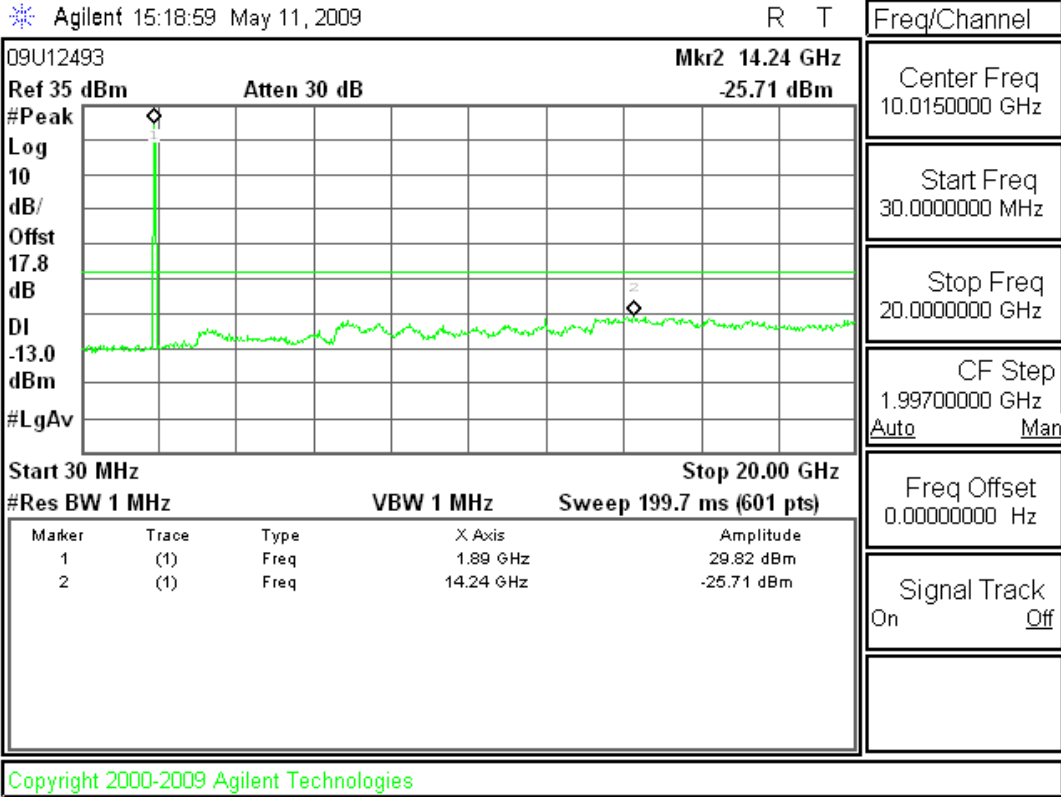

**EGPRS Mode (PCS Band)**

**EGPRS, Ch 512**

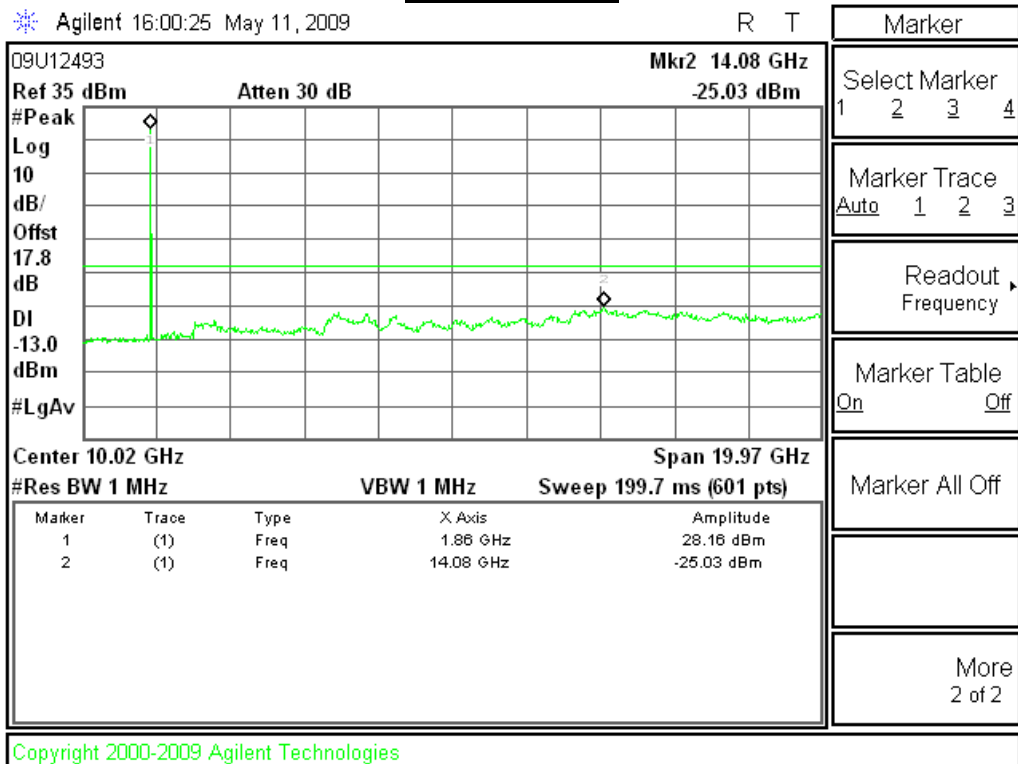

**EGPRS, Ch 661**

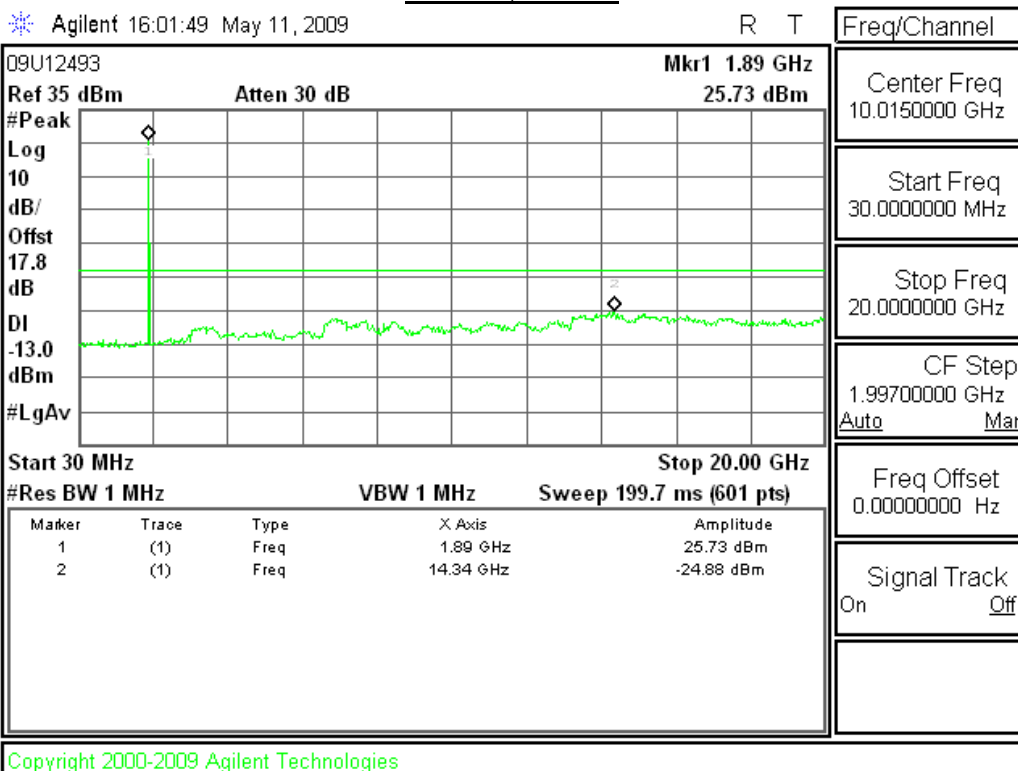

**EGPRS, Ch 810**

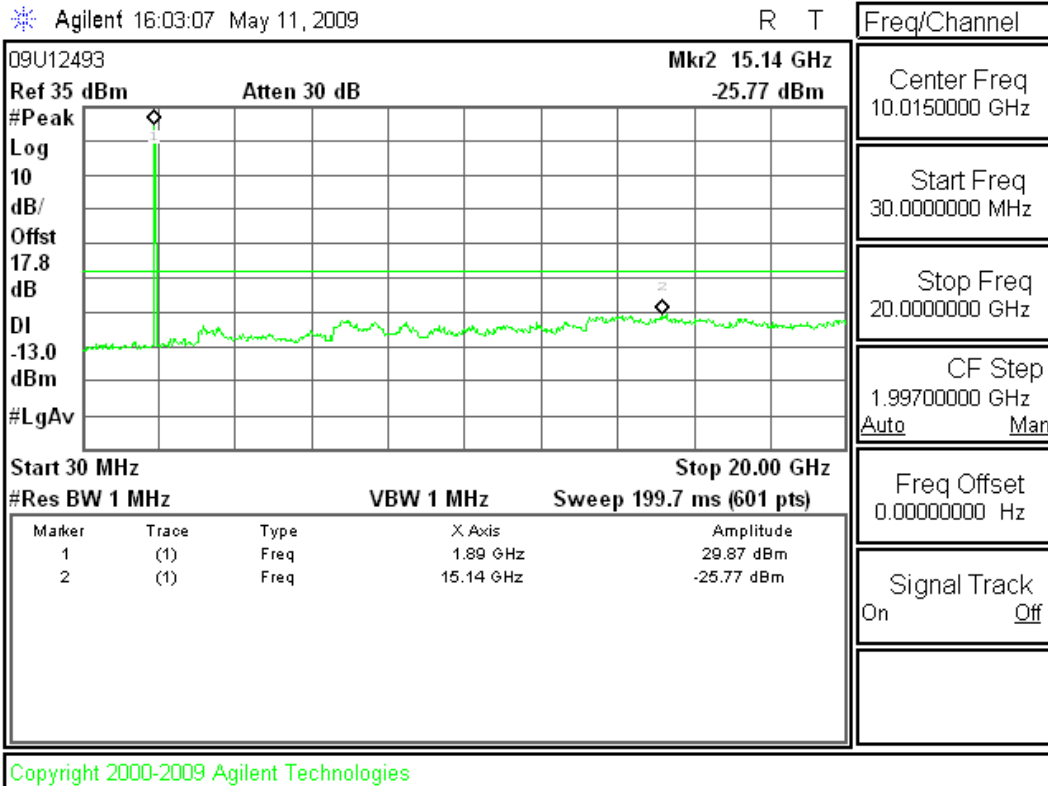

**UMTS Rel 99 Mode (PCS Band)**

UMTS Rel 99, Ch 9262

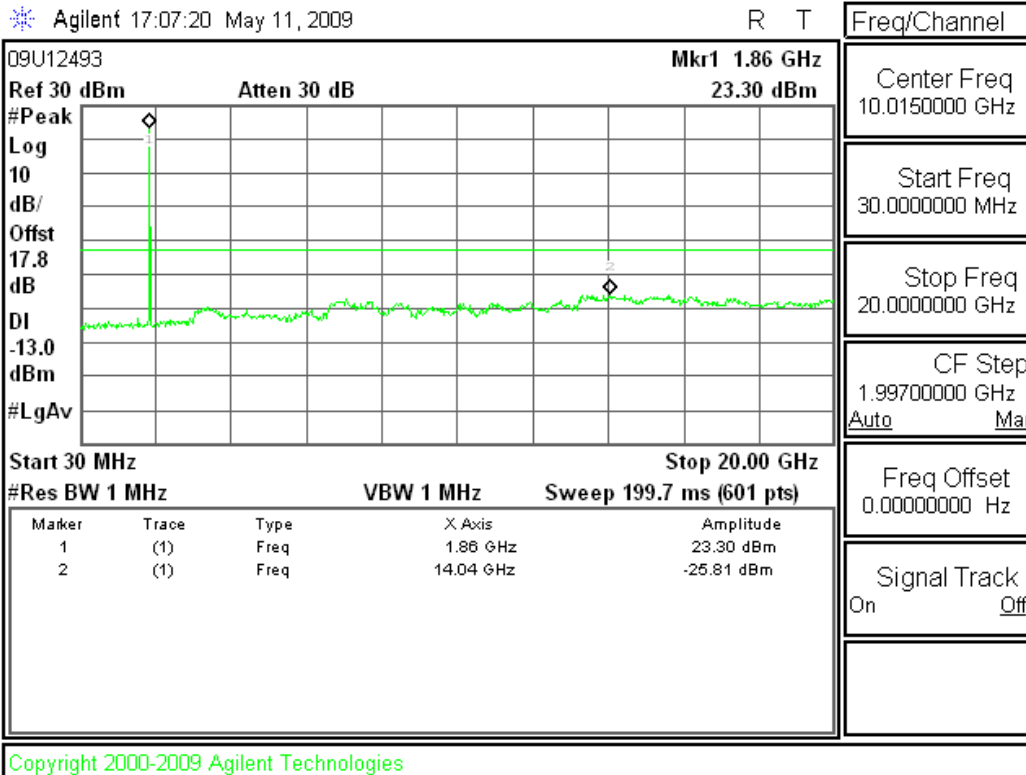

UMTS Rel 99, Ch 9400

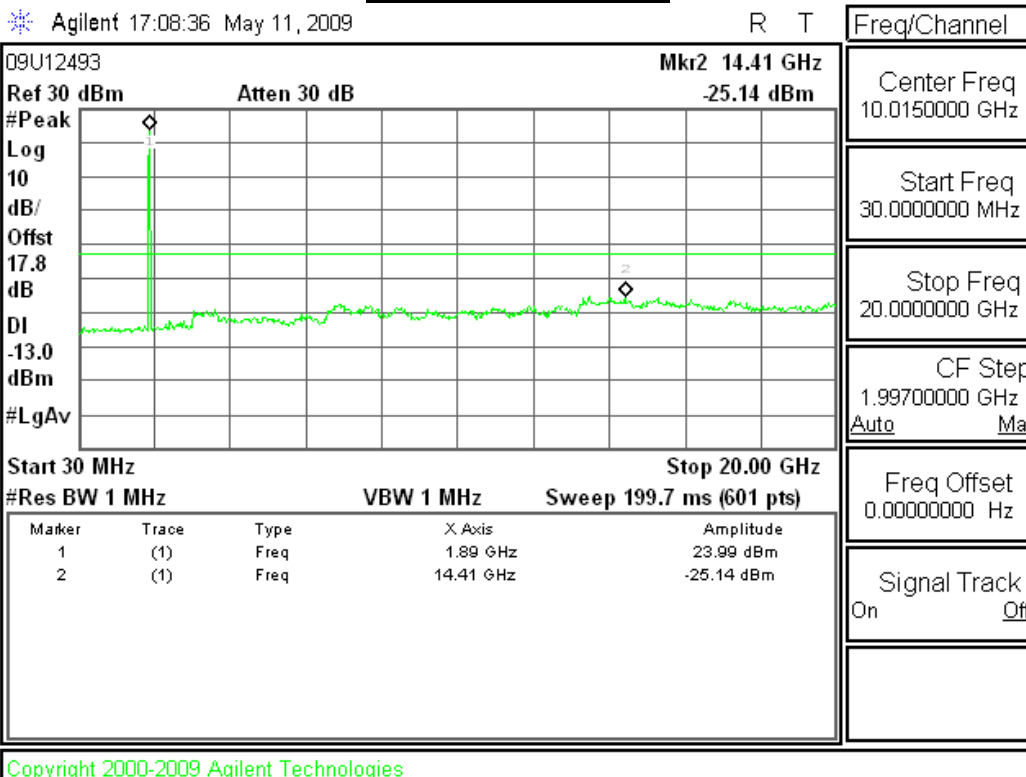



UMTS Rel 99, Ch 9538

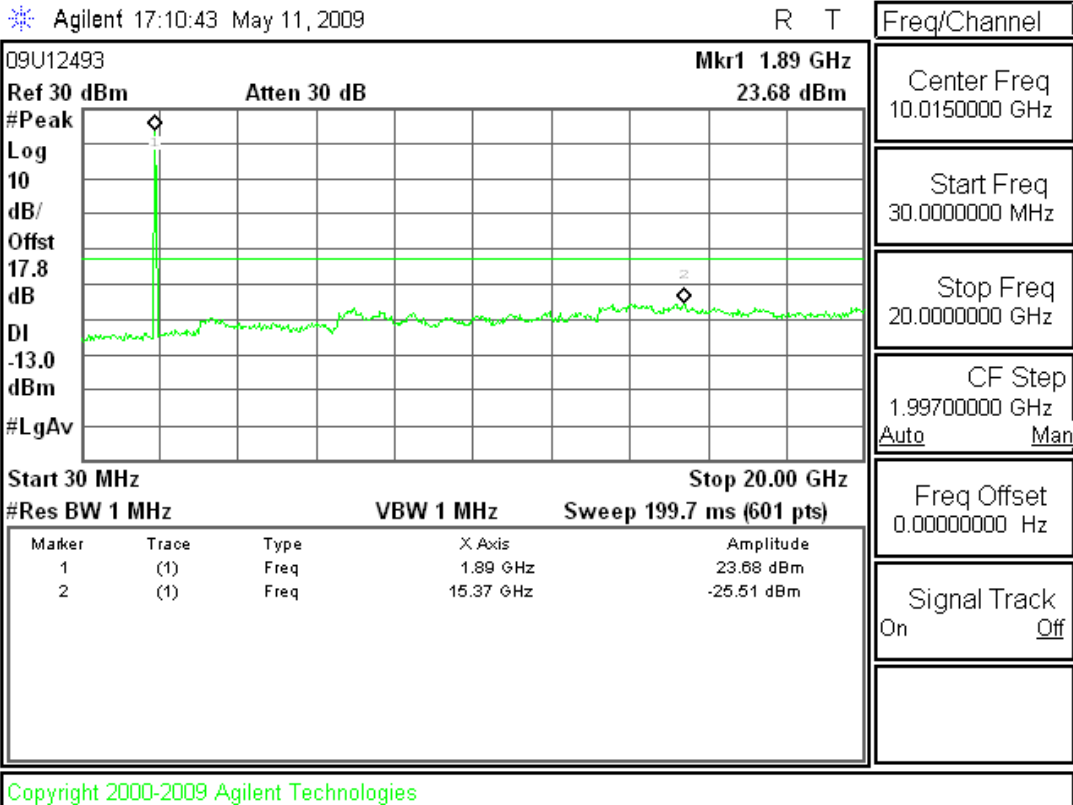

**UMTS Rel 6 HSDPA Subtest 2 Mode (PCS Band)**

**UMTS Rel 6 HSDPA Subtest 2, Ch 9262**

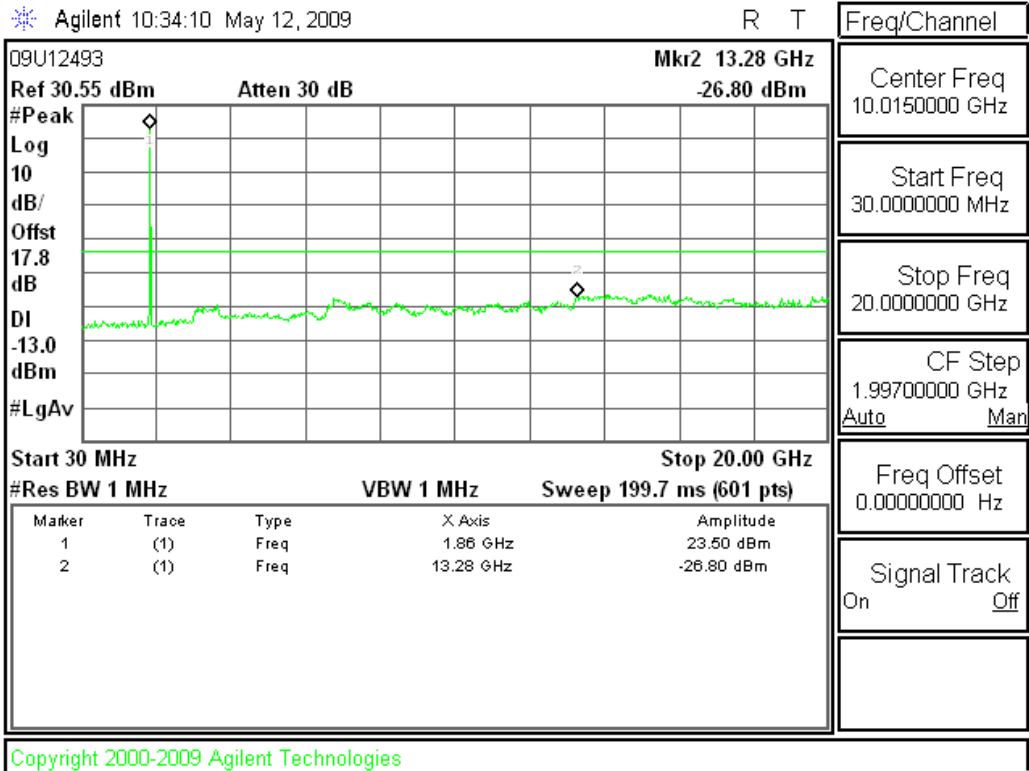

**UMTS Rel 6 HSDPA Subtest 2, Ch 9400**

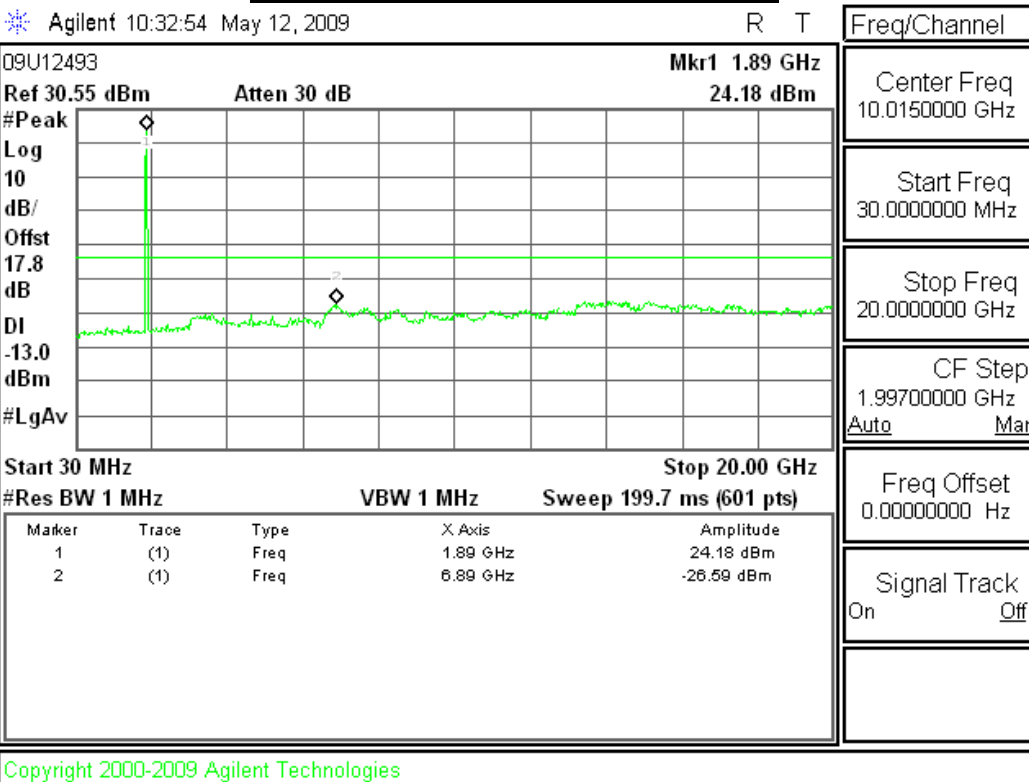

UMTS Rel 6 HSDPA Subtest 2, Ch 9538

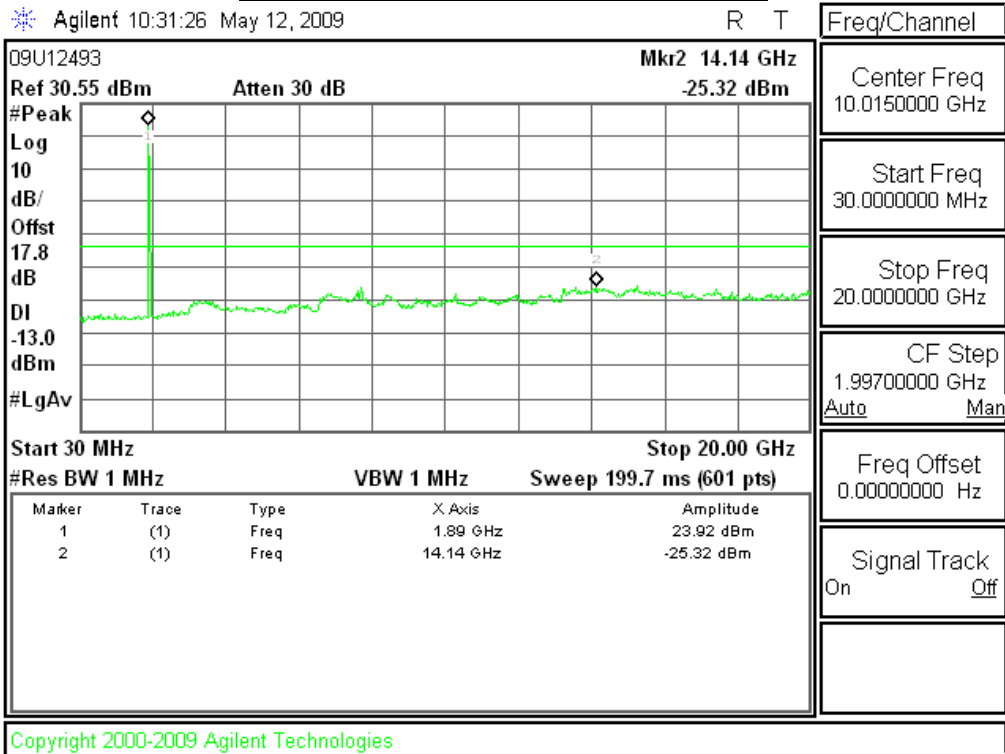

## 11.4. FREQUENCY STABILITY

### RULE PART(S)

FCC: §2.1055, §22.355, §24.235  
IC: RSS-132, 4.3; RSS-133, 6.3

### LIMITS

§22.355 & RSS-132 4.3 - The carrier frequency shall not depart from the reference frequency in excess of  $\pm 2.5$  ppm for mobile stations.

RSS-133 6.3 - The carrier frequency shall not depart from the reference frequency in excess of  $\pm 2.5$  ppm for mobile stations.

§24.235 - The frequency stability shall be sufficient to ensure that the fundamental emission stays within the authorized frequency block.

### TEST PROCEDURE

Use Agilent 8960 with Frequency Error measurement capability.

- Temp. =  $-20^{\circ}$  to  $+50^{\circ}\text{C}$
- Voltage = 3.3 Vdc
- 3.57 – 4.83 Vdc (85% - 115%)

### **Frequency Stability vs Temperature:**

The EUT is placed inside a temperature chamber. The temperature is set to  $20^{\circ}\text{C}$  and allowed to stabilize. After sufficient soak time, the transmitting frequency error is measured. The temperature is increased by 10 degrees, allowed to stabilize and soak, and then the measurement is repeated. This is repeated until  $+50^{\circ}\text{C}$  is reached. Reference power supply voltage for these tests is 4.20 Vdc.

### **Frequency Stability vs Voltage:**

The peak frequency error is recorded (worst-case).  
The test voltages are 3.57 to 4.83 Vdc.

### MODES TESTED

- GSM, EGPRS, UMTS Rel 99 & UMTS HSDPA Rel 6 Subtest 2.

### RESULTS

See the following pages.

**CELL BAND - MID CHANNEL**

**GPRS MODULATION**

Reference Frequency: Cellular Mid Channel 836.4180MHz @ 20°C Limit: to stay +/- 2.5 ppm = 2091.045 Hz				
DC Power Supply (Vdc)	Environment Temperature (°C)	Frequency Deviation Measured with Time Elapse		
		(MHz)	Delta (ppm)	Limit (ppm)
4.20	50	836.417992	0.010	2.5
4.20	40	836.417996	0.005	2.5
4.20	30	836.417994	0.007	2.5
<b>4.20</b>	<b>20</b>	<b>836.418000</b>	<b>0</b>	2.5
4.20	10	836.417986	0.017	2.5
4.20	0	836.417988	0.014	2.5
4.20	-10	836.417993	0.008	2.5
4.20	-20	836.417991	0.011	2.5
4.20	-30	836.417987	0.016	2.5

Reference Frequency: Cellular Mid Channel 836.41800MHz @ 20°C Limit: to stay +/- 2.5 ppm = 2091.045 Hz				
DC Power Supply (Vdc)	Environment Temperature (°C)	Frequency Deviation Measured with Time Elapse		
		(MHz)	Delta (ppm)	Limit (ppm)
<b>100%</b>	<b>20</b>	<b>836.418000</b>	<b>0</b>	<b>2.5</b>
85%	20	836.417996	0.005	2.5
115%	20	836.417992	0.010	2.5

**EGPRS MODULATION**

Reference Frequency: Cellular Mid Channel 836.983MHz @ 20°C Limit: to stay +/- 2.5 ppm = 2092.458 Hz				
DC Power Supply (Vdc)	Environment Temperature (°C)	Frequency Deviation Measured with Time Elapse		
		(MHz)	Delta (ppm)	Limit (ppm)
4.20	50	836.982992	0.010	2.5
4.20	40	836.982990	0.012	2.5
4.20	30	836.983012	-0.014	2.5
<b>4.20</b>	<b>20</b>	<b>836.983000</b>	<b>0</b>	2.5
4.20	10	836.982999	0.002	2.5
4.20	0	836.982998	0.003	2.5
4.20	-10	836.982996	0.005	2.5
4.20	-20	836.982996	0.005	2.5
4.20	-30	836.982992	0.010	2.5

Reference Frequency: Cellular Mid Channel 836.98300MHz @ 20°C Limit: to stay +/- 2.5 ppm = 2092.458 Hz				
DC Power Supply (Vdc)	Environment Temperature (°C)	Frequency Deviation Measured with Time Elapse		
		(MHz)	Delta (ppm)	Limit (ppm)
<b>100%</b>	<b>20</b>	<b>836.983000</b>	<b>0</b>	<b>2.5</b>
85%	20	836.982985	0.017	2.5
115%	20	836.982984	0.019	2.5

**UMTS Rel 99 MODULATION**

Reference Frequency: Cellular Mid Channel 836.4190MHz @ 20°C Limit: to stay +/- 2.5 ppm = 2091.048 Hz				
DC Power Supply (Vdc)	Environment Temperature (°C)	Frequency Deviation Measured with Time Elapse		
		(MHz)	Delta (ppm)	Limit (ppm)
4.20	50	836.419031	-0.037	2.5
4.20	40	836.419026	-0.031	2.5
4.20	30	836.419023	-0.028	2.5
<b>4.20</b>	<b>20</b>	<b>836.419000</b>	<b>0</b>	2.5
4.20	10	836.419015	-0.018	2.5
4.20	0	836.419016	-0.019	2.5
4.20	-10	836.419017	-0.020	2.5
4.20	-20	836.419021	-0.025	2.5
4.20	-30	836.419024	-0.028	2.5

Reference Frequency: Cellular Mid Channel 836.41900MHz @ 20°C Limit: to stay +/- 2.5 ppm = 2091.048 Hz				
DC Power Supply (Vdc)	Environment °C	Frequency Deviation Measured with Time Elapse		
		(MHz)	Delta (ppm)	Limit (ppm)
<b>100%</b>	<b>20</b>	<b>836.419000</b>	<b>0</b>	<b>2.5</b>
85%	20	836.419025	-0.029	2.5
115%	20	836.419033	-0.039	2.5

**PCS BAND – MID CHANNEL**

**GPRS MODULATION**

Reference Frequency: PCS Mid Channel 1880.0180MHz @ 20°C				
Limit: within the authorized block or +/- 2.5 ppm = 4700.045 Hz				
Power Supply (Vdc)	Environment Temperature (°C)	Frequency Deviation Measured with Time Elapse		
		(MHz)	Delta (ppm)	Limit (ppm)
4.20	50	1880.017966	0.018	2.5
4.20	40	1880.017951	0.026	2.5
4.20	30	1880.017947	0.028	2.5
<b>4.20</b>	<b>20</b>	<b>1880.01800</b>	<b>0</b>	<b>2.5</b>
4.20	10	1880.017997	0.002	2.5
4.20	0	1880.017994	0.003	2.5
4.20	-10	1880.017989	0.006	2.5
4.20	-20	1880.017985	0.008	2.5
4.20	-30	1880.017970	0.016	2.5

Reference Frequency: PCS Mid Channel 1880.0180MHz @ 20°C				
Limit: within the authorized block or +/- 2.5 ppm = 4700.045 Hz				
Power Supply (Vdc)	Environment Temperature (°C)	Frequency Deviation Measured with Time Elapse		
		(MHz)	Delta (ppm)	Limit (ppm)
<b>100%</b>	<b>20</b>	<b>1880.018000</b>	<b>0</b>	<b>2.5</b>
85%	20	1880.017958	0.022	2.5
115%	20	1880.017947	0.028	2.5

**EGPRS MODULATION**

Reference Frequency: PCS Mid Channel 1880.02980MHz @ 20°C				
Limit: within the authorized block or +/- 2.5 ppm = 4700.075 Hz				
Power Supply (Vdc)	Environment Temperature (°C)	Frequency Deviation Measured with Time Elapse		
		(MHz)	Delta (ppm)	Limit (ppm)
4.20	50	1880.029768	0.017	2.5
4.20	40	1880.029759	0.022	2.5
4.20	30	1880.029779	0.011	2.5
<b>4.20</b>	<b>20</b>	<b>1880.029800</b>	<b>0</b>	<b>2.5</b>
4.20	10	1880.029797	0.002	2.5
4.20	0	1880.029076	0.385	2.5
4.20	-10	1880.029791	0.005	2.5
4.20	-20	1880.029787	0.007	2.5
4.20	-30	1880.029769	0.017	2.5

Reference Frequency: PCS Mid Channel 1880.02980MHz @ 20°C				
Limit: within the authorized block or +/- 2.5 ppm = 4700.075 Hz				
Power Supply (Vdc)	Environment Temperature (°C)	Frequency Deviation Measured with Time Elapse		
		(MHz)	Delta (ppm)	Limit (ppm)
<b>100%</b>	<b>20</b>	<b>1880.029800</b>	<b>0</b>	<b>2.5</b>
85%	20	1880.029767	0.018	2.5
115%	20	1880.029749	0.027	2.5

**UMTS Rel 99 MODULATION**

Reference Frequency: PCS Mid Channel 1880.02000MHz @ 20°C				
Limit: within the authorized block or +/- 2.5 ppm = 4700.050 Hz				
Power Supply (Vdc)	Environment Temperature (°C)	Frequency Deviation Measured with Time Elapse		
		(MHz)	Delta (ppm)	Limit (ppm)
4.20	50	1880.020035	-0.019	2.5
4.20	40	1880.020032	-0.017	2.5
4.20	30	1880.020029	-0.016	2.5
<b>4.20</b>	<b>20</b>	<b>1880.020000</b>	<b>0</b>	<b>2.5</b>
4.20	10	1880.020020	-0.011	2.5
4.20	0	1880.020023	-0.012	2.5
4.20	-10	1880.020024	-0.013	2.5
4.20	-20	1880.020030	-0.016	2.5
4.20	-30	1880.020041	-0.022	2.5

Reference Frequency: PCS Mid Channel 1880.0200MHz @ 20°C				
Limit: within the authorized block or +/- 2.5 ppm = 4700.050 Hz				
Power Supply (Vdc)	Environment Temperature (°C)	Frequency Deviation Measured with Time Elapse		
		(MHz)	Delta (ppm)	Limit (ppm)
<b>100%</b>	<b>20</b>	<b>1880.020000</b>	<b>0</b>	<b>2.5</b>
85%	20	1880.020026	-0.014	2.5
115%	20	1880.020034	-0.018	2.5



## **12. RADIATED TEST RESULTS**

### **12.1. RADIATED POWER (ERP & EIRP)**

#### **RULE PART(S)**

FCC: §2.1046, §22.913, §24.232  
IC: RSS-132; 4.4, RSS-133, 6.4

#### **LIMITS**

22.913(a) - The ERP of mobile transmitters and auxiliary test transmitters must not exceed 7 Watts.

24.232(c) & RSS-133 § 6.4 - Mobile/portable stations are limited to 2 watts e.i.r.p. peak power and the equipment must employ means to limit the power to the minimum necessary for successful communications.

RSS-132 4.4, SRSP503 5.1.3 - The maximum ERP shall be 11.5 Watts for mobile stations.

#### **TEST PROCEDURE**

ANSI / TIA / EIA 603C  
RSS-132; RSS-133

#### **MODES TESTED**

- GSM, EGPRS, Rel 99 & HSDPA Rel 6 Subtest 2.

**RESULTS for Cellular Band (ERP)**

Mode	Channel	f (MHz)	ERP	
			dBm	mW
GPRS	128	824.20	28.40	691.83
	190	836.60	28.50	707.95
	251	848.80	28.50	707.95
EGPRS	128	824.20	27.00	501.19
	190	836.60	26.70	467.74
	251	848.80	27.40	549.54

Mode	Channel	f (MHz)	ERP	
			dBm	mW
Rel 99	4132	826.40	22.30	169.82
	4180	836.00	23.40	218.78
	4230	846.00	23.50	223.87
HSDPA (Subtest 2)	4132	826.40	23.30	213.80
	4180	836.00	23.80	239.88
	4230	846.00	23.50	223.87

**RESULTS for PCS Band (EIRP)**

Mode	Channel	f (MHz)	EIRP	
			dBm	mW
GPRS	512	1850.20	32.50	1778.28
	661	1880.00	32.70	1862.09
	810	1909.80	32.40	1737.80
EGPRS	512	1850.20	32.10	1621.81
	661	1880.00	32.30	1698.24
	810	1909.80	31.40	1380.38

Mode	Channel	f (MHz)	EIRP	
			dBm	mW
Rel 99	9262	1852.40	28.60	724.44
	9400	1880.00	30.00	1000.00
	9538	1907.60	29.50	891.25
HSDPA (Subtest 2)	9262	1852.40	28.70	741.31
	9400	1880.00	29.50	891.25
	9538	1907.60	29.60	912.01

**GPRS Mode (Cellular Band)**

High Frequency Substitution Measurement Compliance Certification Services Chamber B							
<b>Company:</b>		INTERMEC TECHNOLOGIES CORP.					
<b>Project #:</b>		09U12493					
<b>Date:</b>		5/5/2009					
<b>Test Engineer:</b>		MENGISTU MEKURIA					
<b>Configuration:</b>		EUT ALONE					
<b>Mode:</b>		TX, GPRS, CELL BAND					
<b>Test Equipment:</b>							
Receiving: Sunol T130, and 3m Chamber N-type Cable (Setup this one for testing EUT)							
Substitution: Dipole S/N: 00022117, 6ft SMA Cable (SN # 208947003) Warehouse.							
f MHz	SA reading (dBm)	Ant. Pol. (H/V)	Path Loss (dBm)	ERP (dBm)	Limit (dBm)	Margin (dB)	Notes
824.20	-4.2	V	32.6	28.4	38.5	-10.0	
824.20	-7.1	H	30.4	23.2	38.5	-15.2	
836.60	-4.2	V	32.7	28.5	38.5	-10.0	
836.60	-6.7	H	30.7	24.0	38.5	-14.4	
848.80	-3.5	V	32.0	28.5	38.5	-9.9	
848.80	-5.7	H	30.8	25.1	38.5	-13.4	
Rev. 1.24.7							

**EGPRS Mode (Cellular Band)**

High Frequency Substitution Measurement Compliance Certification Services Chamber B							
<b>Company:</b>		INTERMEC TECHNOLOGIES CORP.					
<b>Project #:</b>		09U12493					
<b>Date:</b>		5/5/2009					
<b>Test Engineer:</b>		MENGISTU MEKURIA					
<b>Configuration:</b>		EUT ALONE					
<b>Mode:</b>		TX, EGPRS, CELL BAND					
<b>Test Equipment:</b>							
Receiving: Sunol T130, and 3m Chamber N-type Cable (Setup this one for testing EUT)							
Substitution: Dipole S/N: 00022117, 6ft SMA Cable (SN # 208947003) Warehouse.							
f MHz	SA reading (dBm)	Ant. Pol. (H/V)	Path Loss (dBm)	ERP (dBm)	Limit (dBm)	Margin (dB)	Notes
824.20	-5.6	V	32.6	27.0	38.5	-11.5	
824.20	-7.7	H	30.4	22.7	38.5	-15.8	
836.60	-5.9	V	32.7	26.7	38.5	-11.7	
836.60	-7.7	H	30.7	23.0	38.5	-15.4	
848.80	-4.6	V	32.0	27.4	38.5	-11.1	
848.80	-6.8	H	30.8	24.0	38.5	-14.5	
Rev. 1.24.7							

**UMTS Rel 99 Mode (Cellular Band)**

High Frequency Substitution Measurement Compliance Certification Services Chamber B							
<b>Company:</b>		INTERMEC TECHNOLOGIES CORP.					
<b>Project #:</b>		09U12493					
<b>Date:</b>		5/12/2009					
<b>Test Engineer:</b>		MENGISTU MEKURIA					
<b>Configuration:</b>		EUT ALONE					
<b>Mode:</b>		TX, WCDMA, CELL BAND					
<b>Test Equipment:</b>							
Receiving: Sunol T130, and 3m Chamber N-type Cable (Setup this one for testing EUT)							
Substitution: Dipole S/N: 00022117, 6ft SMA Cable (SN # 208947003) Warehouse.							
f MHz	SA reading (dBm)	Ant. Pol. (H/V)	Path Loss (dBm)	ERP (dBm)	Limit (dBm)	Margin (dB)	Notes
826.40	-10.3	V	32.6	22.3	38.5	-16.2	
826.40	-11.9	H	30.4	18.5	38.5	-20.0	
836.60	-9.2	V	32.7	23.4	38.5	-15.0	
836.60	-11.0	H	30.7	19.8	38.5	-18.7	
846.00	-8.4	V	32.0	23.5	38.5	-14.9	
846.00	-9.8	H	30.8	21.0	38.5	-17.5	
Rev. 1.24.7							

**UMTS Rel 6 HSDPA Mode (Cellular Band)**

High Frequency Substitution Measurement Compliance Certification Services Chamber B							
<b>Company:</b>		INTERMEC TECHNOLOGIES CORP.					
<b>Project #:</b>		09U12493					
<b>Date:</b>		5/12/2009					
<b>Test Engineer:</b>		MENGISTU MEKURIA					
<b>Configuration:</b>		EUT ALONE					
<b>Mode:</b>		TX, HSDPA, CELL BAND					
<b>Test Equipment:</b>							
Receiving: Sunol T130, and 3m Chamber N-type Cable (Setup this one for testing EUT)							
Substitution: Dipole S/N: 00022117, 6ft SMA Cable (SN # 208947003) Warehouse.							
f MHz	SA reading (dBm)	Ant. Pol. (H/V)	Path Loss (dBm)	ERP (dBm)	Limit (dBm)	Margin (dB)	Notes
826.40	-9.3	V	32.6	23.3	38.5	-15.1	
826.40	-12.0	H	30.4	18.4	38.5	-20.1	
836.60	-8.9	V	32.7	23.8	38.5	-14.7	
836.60	-10.6	H	30.7	20.2	38.5	-18.3	
846.00	-8.5	V	32.0	23.5	38.5	-15.0	
846.00	-9.9	H	30.8	20.9	38.5	-17.6	
Rev. 1.24.7							

**GPRS Mode (PCS Band)**

High Frequency Fundamental Measurement Compliance Certification Services Chamber B							
<b>Company:</b>		INTERMEC TECHNOLOGIES CORP.					
<b>Project #:</b>		09U12493					
<b>Date:</b>		5/5/2009					
<b>Test Engineer:</b>		MENGISTU MEKURIA					
<b>Configuration:</b>		EUT ALONE					
<b>Mode:</b>		TX, GPRS, PCS BAND					
<b>Test Equipment:</b>							
Receiving: Horn T59, and Camber B SMA Cables							
Substitution: Horn T72 Substitution, 6ft SMA Cable (208947003) Warehouse							
f GHz	SA reading (dBm)	Ant. Pol. (H/V)	Path Loss (dBm)	EIRP (dBm)	Limit (dBm)	Delta (dB)	Notes
1.850	-11.8	V	40.2	28.4	33.0	-4.6	
1.850	-7.0	H	39.5	32.5	33.0	-0.5	
1.880	-13.2	V	40.3	27.1	33.0	-5.9	
1.880	-7.4	H	40.1	32.7	33.0	-0.3	
1.910	-14.3	V	40.2	25.9	33.0	-7.1	
1.910	-7.7	H	40.1	32.4	33.0	-0.6	
Rev. 1.24.7							

**EGPRS Mode (PCS Band)**

High Frequency Fundamental Measurement Compliance Certification Services Chamber B							
<b>Company:</b>		INTERMEC TECHNOLOGIES CORP.					
<b>Project #:</b>		09U12493					
<b>Date:</b>		5/5/2009					
<b>Test Engineer:</b>		MENGISTU MEKURIA					
<b>Configuration:</b>		EUT ALONE					
<b>Mode:</b>		TX, EGPRS, PCS BAND					
<b>Test Equipment:</b>							
Receiving: Horn T59, and Camber B SMA Cables							
Substitution: Horn T72 Substitution, 6ft SMA Cable (208947003) Warehouse							
f GHz	SA reading (dBm)	Ant. Pol. (H/V)	Path Loss (dBm)	EIRP (dBm)	Limit (dBm)	Delta (dB)	Notes
1.850	-14.8	V	40.2	25.3	33.0	-7.7	
1.850	-7.4	H	39.5	32.1	33.0	-0.9	
1.880	-16.5	V	40.3	23.7	33.0	-9.3	
1.880	-7.9	H	40.1	32.3	33.0	-0.8	
1.910	-17.5	V	40.2	22.7	33.0	-10.3	
1.910	-8.7	H	40.1	31.4	33.0	-1.6	
Rev. 1.24.7							

**UMTS Rel 99 Mode (PCS Band)**

High Frequency Fundamental Measurement Compliance Certification Services Chamber B							
<b>Company:</b>		INTERMEC TECHNOLOGIES CORP.					
<b>Project #:</b>		09U12493					
<b>Date:</b>		5/12/2009					
<b>Test Engineer:</b>		MENGISTU MEKURIA					
<b>Configuration:</b>		EUT ALONE					
<b>Mode:</b>		TX, WCDMA, PCS BAND					
<b>Test Equipment:</b>							
Receiving: Horn T59, and Camber B SMA Cables							
Substitution: Horn T72 Substitution, 6ft SMA Cable (208947003) Warehouse							
f GHz	SA reading (dBm)	Ant. Pol. (H/V)	Path Loss (dBm)	EIRP (dBm)	Limit (dBm)	Delta (dB)	Notes
1.850	-15.1	V	40.2	25.1	33.0	-7.9	
1.850	-10.9	H	39.5	28.6	33.0	-4.5	
1.880	-14.0	V	40.3	26.3	33.0	-6.7	
1.880	-10.1	H	40.1	30.0	33.0	-3.0	
1.910	-15.3	V	40.2	24.9	33.0	-8.1	
1.910	-10.6	H	40.1	29.5	33.0	-3.5	
Rev. 1.24.7							

**UMTS Rel 6 HSDPA Mode (PCS Band)**

High Frequency Fundamental Measurement Compliance Certification Services Chamber B							
<b>Company:</b>		INTERMEC TECHNOLOGIES CORP.					
<b>Project #:</b>		09U12493					
<b>Date:</b>		5/12/2009					
<b>Test Engineer:</b>		MENGISTU MEKURIA					
<b>Configuration:</b>		EUT ALONE					
<b>Mode:</b>		TX, HSDPA, PCS BAND					
<b>Test Equipment:</b>							
Receiving: Horn T59, and Camber B SMA Cables							
Substitution: Horn T72 Substitution, 6ft SMA Cable (208947003) Warehouse							
f GHz	SA reading (dBm)	Ant. Pol. (H/V)	Path Loss (dBm)	EIRP (dBm)	Limit (dBm)	Delta (dB)	Notes
1.850	-14.8	V	40.2	25.4	33.0	-7.6	
1.850	-10.8	H	39.5	28.7	33.0	-4.3	
1.880	-15.3	V	40.3	25.0	33.0	-8.1	
1.880	-10.6	H	40.1	29.5	33.0	-3.5	
1.910	-14.9	V	40.2	25.3	33.0	-7.7	
1.910	-10.5	H	40.1	29.6	33.0	-3.4	
Rev. 1.24.7							

## **12.2. FIELD STRENGTH OF SPURIOUS RADIATION**

### **RULE PART(S)**

FCC: §2.1053, §22.917, §24.238  
IC: RSS-132, 4.5; RSS-233, 6.5

### **LIMIT**

The power of any emission outside of the authorized operating frequency ranges must be attenuated below the transmitting power (P) by a factor of at least  $43 + 10 \log (P)$  dB.

### **TEST PROCEDURE**

For Cellular equipment - Compliance with these rules is based on the use of measurement instrumentation employing a resolution bandwidth of 100 kHz or greater. In the 1 MHz bands immediately outside and adjacent to the frequency block a resolution bandwidth of at least one percent of the emission bandwidth of the fundamental emission of the transmitter may be employed. A narrower resolution bandwidth is permitted in all cases to improve measurement accuracy provided the measured power is integrated over the full required measurement bandwidth ( i.e. 100 kHz or 1 percent of emission bandwidth, as specified). The emission bandwidth is defined as the width of the signal between two points, one below the carrier center frequency and one above the carrier center frequency, outside of which all emissions are attenuated at least 26 dB below the transmitter power.

For PCS equipment - Compliance with these rules is based on the use of measurement instrumentation employing a resolution bandwidth of 1 MHz or greater. However, in the 1 MHz bands immediately outside and adjacent to the frequency block a resolution bandwidth of at least one percent of the emission bandwidth of the fundamental emission of the transmitter may be employed. A narrower resolution bandwidth is permitted in all cases to improve measurement accuracy provided the measured power is integrated over the full required measurement bandwidth ( i.e. 1 MHz or 1 percent of emission bandwidth, as specified). The emission bandwidth is defined as the width of the signal between two points, one below the carrier center frequency and one above the carrier center frequency, outside of which all emissions are attenuated at least 26 dB below the transmitter power.

### **MODES TESTED**

- GSM, EGPRS, Rel 99 & HSDPA Rel 6 Subtest 2.

### **RESULTS**

See the following pages.

**GPRS Mode (Cellular Band)**

Compliance Certification Services Above 1GHz High Frequency Substitution Measurement										
<b>Company:</b>		INTERMEC TECHNOLOGIES CORP.								
<b>Project #:</b>		09U12493								
<b>Date:</b>		5/7/2009								
<b>Test Engineer:</b>		MENGISTU MEKURIA								
<b>Configuration:</b>		EUT ALONE								
<b>Mode:</b>		TX, GPRS, CELL BAND								
<b>Chamber</b>		<b>Pre-amplifier</b>			<b>Filter</b>			<b>Limit</b>		
5m Chamber A		T144 8449B			Filter 1			FCC PART 22 Tx		
f GHz	SA reading (dBm)	Ant. Pol. (H/V)	Distance (m)	Path Loss (dB)	Preamp (dB)	Filter (dB)	EIRP (dBm)	Limit (dBm)	Delta (dB)	Notes
<b>Low Ch. (824.2 MHz)</b>										
1.6484	-56.0	H	3.0	36.5	38.2	1.0	-56.6	-13.0	-43.6	
2.4726	-42.0	H	3.0	40.0	37.5	1.0	-38.5	-13.0	-25.5	
8.2420	-64.9	H	3.0	54.0	36.8	1.0	-46.7	-13.0	-33.7	
1.6484	-52.1	V	3.0	36.8	38.2	1.0	-52.5	-13.0	-39.5	
2.4726	-44.8	V	3.0	41.7	37.5	1.0	-39.6	-13.0	-26.6	
8.2420	-62.5	V	3.0	52.9	36.8	1.0	-45.3	-13.0	-32.3	
<b>Mid Ch. (836.6 MHz)</b>										
1.6732	-55.3	H	3.0	36.8	38.1	1.0	-55.6	-13.0	-42.6	
2.5098	-46.4	H	3.0	40.1	37.5	1.0	-42.7	-13.0	-29.7	
8.3860	-65.8	H	3.0	54.2	36.8	1.0	-47.5	-13.0	-34.5	
1.6732	-51.3	V	3.0	37.1	38.1	1.0	-51.3	-13.0	-38.3	
2.5098	-48.2	V	3.0	41.9	37.5	1.0	-42.8	-13.0	-29.8	
8.3860	-63.2	V	3.0	53.1	36.8	1.0	-45.9	-13.0	-32.9	
<b>Hi Ch. (848.8 MHz)</b>										
1.6976	-52.4	H	3.0	37.0	38.1	1.0	-52.4	-13.0	-39.4	
2.5464	-46.1	H	3.0	40.4	37.5	1.0	-42.2	-13.0	-29.2	
8.4880	-66.1	H	3.0	54.3	36.8	1.0	-47.7	-13.0	-34.7	
1.6976	-47.6	V	3.0	37.4	38.1	1.0	-47.4	-13.0	-34.4	
2.5464	-47.1	V	3.0	42.0	37.5	1.0	-41.6	-13.0	-28.6	
8.4880	-65.2	V	3.0	53.2	36.8	1.0	-47.8	-13.0	-34.8	
Rev. 03.03.09										



**EGPRS Mode (Cellular Band)**

Compliance Certification Services Above 1GHz High Frequency Substitution Measurement										
<b>Company:</b>		INTERMEC TECHNOLOGIES CORP.								
<b>Project #:</b>		09U12493								
<b>Date:</b>		5/7/2009								
<b>Test Engineer:</b>		MENGISTU MEKURIA								
<b>Configuration:</b>		EUT ALONE								
<b>Mode:</b>		TX, EGPRS, CELL BAND								
<b>Chamber</b>		<b>Pre-amplifier</b>			<b>Filter</b>			<b>Limit</b>		
5m Chamber A		T144 8449B			Filter 1			FCC PART 22 Tx		
f GHz	SA reading (dBm)	Ant. Pol. (H/V)	Distance (m)	Path Loss (dB)	Preamp (dB)	Filter (dB)	EIRP (dBm)	Limit (dBm)	Delta (dB)	Notes
<b>Low Ch. (824.2 MHz)</b>										
1.6484	-53.1	H	3.0	36.5	38.2	1.0	-53.7	-13.0	-40.7	
2.4726	-42.1	H	3.0	40.0	37.5	1.0	-38.7	-13.0	-25.7	
8.2420	-62.6	H	3.0	54.0	36.8	1.0	44.4	-13.0	-31.4	
1.6484	-52.7	V	3.0	36.8	38.2	1.0	-53.0	-13.0	-40.0	
2.4726	-44.6	V	3.0	41.7	37.5	1.0	-39.3	-13.0	-26.3	
8.2420	-63.3	V	3.0	52.9	36.8	1.0	-46.2	-13.0	-33.2	
<b>Mid Ch. (836.6 MHz)</b>										
1.6732	-54.7	H	3.0	36.8	38.1	1.0	-55.0	-13.0	-42.0	
2.5098	-45.9	H	3.0	40.1	37.5	1.0	-42.2	-13.0	-29.2	
8.3660	-63.6	H	3.0	54.1	36.8	1.0	-45.3	-13.0	-32.3	
1.6732	-52.1	V	3.0	37.1	38.1	1.0	-52.1	-13.0	-39.1	
2.5098	-49.0	V	3.0	41.9	37.5	1.0	-43.6	-13.0	-30.6	
8.3660	-62.9	V	3.0	53.1	36.8	1.0	-45.6	-13.0	-32.6	
<b>Hi Ch. (848.8 MHz)</b>										
1.6976	-51.3	H	3.0	37.0	38.1	1.0	-51.4	-13.0	-38.4	
2.5464	-43.3	H	3.0	40.4	37.5	1.0	-39.4	-13.0	-26.4	
8.4880	-61.4	H	3.0	54.3	36.8	1.0	-42.9	-13.0	-29.9	
1.6976	-50.9	V	3.0	37.4	38.1	1.0	-50.6	-13.0	-37.6	
2.5464	-43.5	V	3.0	42.0	37.5	1.0	-38.0	-13.0	-25.0	
8.4880	-62.1	V	3.0	53.2	36.8	1.0	-44.7	-13.0	-31.7	
Rev. 03.03.09										

**UMTS REL 99 Mode (Cellular Band)**

Compliance Certification Services										
Above 1GHz High Frequency Substitution Measurement										
<b>Company:</b>		INTERMEC TECHNOLOGISES CORP.								
<b>Project #:</b>		09U12493								
<b>Date:</b>		5/7/2009								
<b>Test Engineer:</b>		MENGISTU MEKURIA								
<b>Configuration:</b>		EUT ALONE								
<b>Mode:</b>		TX, WCDMA, CELL BAND								
<b>Chamber</b>		<b>Pre-amplifier</b>			<b>Filter</b>			<b>Limit</b>		
5m Chamber A		T144 8449B			Filter 1			FCC PART 22 Tx		
f GHz	SA reading (dBm)	Ant. Pol. (H/V)	Distance (m)	Path Loss (dB)	Preamp (dB)	Filter (dB)	EIRP (dBm)	Limit (dBm)	Delta (dB)	Notes
<b>Low Ch. (826.4 MHz)</b>										
1.6528	-59.4	H	3.0	36.6	38.1	1.0	-59.9	-13.0	-46.9	
2.4792	-63.6	H	3.0	40.0	37.5	1.0	-60.0	-13.0	-47.0	
1.6528	-54.6	V	3.0	36.9	38.1	1.0	-54.9	-13.0	-41.9	
2.4792	-63.9	V	3.0	41.7	37.5	1.0	-58.6	-13.0	-45.6	
<b>Mid Ch. (836.4 MHz)</b>										
1.6728	-59.2	H	3.0	36.8	38.1	1.0	-59.5	-13.0	-46.5	
2.5092	-64.0	H	3.0	40.1	37.5	1.0	-60.3	-13.0	-47.3	
1.6728	-55.5	V	3.0	37.1	38.1	1.0	-55.5	-13.0	-42.5	
2.5092	-64.2	V	3.0	41.8	37.5	1.0	-58.8	-13.0	-45.8	
<b>Hi Ch. (846.6 MHz)</b>										
1.6932	-57.3	H	3.0	37.0	38.1	1.0	-57.4	-13.0	-44.4	
2.5398	-62.6	H	3.0	40.3	37.5	1.0	-58.7	-13.0	-45.7	
1.6932	-52.7	V	3.0	37.3	38.1	1.0	-52.5	-13.0	-39.5	
2.5398	-61.4	V	3.0	41.9	37.5	1.0	-55.9	-13.0	-42.9	
		V								
		V								
Rev. 03.03.09										

**UMTS REL 6 HSDPA Subtest 2 Mode (Cellular Band)**

**Compliance Certification Services**  
**Above 1GHz High Frequency Substitution Measurement**

**Company:** INTERMEC TECHNOLOGISES CORP.  
**Project #:** 09U12493  
**Date:** 5/7/2009  
**Test Engineer:** MENGISTU MEKURIA  
**Configuration:** EUT ALONE  
**Mode:** TX, HSDPA, CELL BAND

Chamber

Pre-amplifier

Filter

Limit

5m Chamber A

T144 8449B

Filter 1

FCC PART 22 Tx

f GHz	SA reading (dBm)	Ant. Pol. (H/V)	Distance (m)	Path Loss (dB)	Preamp (dB)	Filter (dB)	EIRP (dBm)	Limit (dBm)	Delta (dB)	Notes
<b>Low Ch. (826.4 MHz)</b>										
1.6528	-57.5	H	3.0	36.6	38.1	1.0	-58.0	-13.0	-45.0	
2.4792	-61.2	H	3.0	40.0	37.5	1.0	-57.7	-13.0	-44.7	
1.6528	-52.6	V	3.0	36.9	38.1	1.0	-52.9	-13.0	-39.9	
2.4792	-60.4	V	3.0	41.7	37.5	1.0	-55.2	-13.0	-42.2	
<b>Mid Ch. (836.4 MHz)</b>										
1.6728	-55.7	H	3.0	36.8	38.1	1.0	-56.1	-13.0	-43.1	
2.5092	-60.8	H	3.0	40.1	37.5	1.0	-57.1	-13.0	-44.1	
1.6728	-52.4	V	3.0	37.1	38.1	1.0	-52.4	-13.0	-39.4	
2.5092	-61.2	V	3.0	41.8	37.5	1.0	-55.8	-13.0	-42.8	
<b>Hi Ch. (846.6 MHz)</b>										
1.6932	-54.3	H	3.0	37.0	38.1	1.0	-54.4	-13.0	-41.4	
2.5398	-59.4	H	3.0	40.3	37.5	1.0	-55.6	-13.0	-42.6	
1.6932	-51.7	V	3.0	37.3	38.1	1.0	-51.5	-13.0	-38.5	
2.5398	-62.4	V	3.0	41.9	37.5	1.0	-56.9	-13.0	-43.9	
		V								
		V								

Rev. 03.03.09

**GPRS Mode (PCS Band)**

**Compliance Certification Services**  
**Above 1GHz High Frequency Substitution Measurement**

**Company:** INTERMEC TECHNOLOGIES CORP.  
**Project #:** 09U12493  
**Date:** 5/7/2009  
**Test Engineer:** MENGISTU MEKURIA  
**Configuration:** EUT ALONE  
**Mode:** TX, GPRS, PCS BAND

Chamber

Pre-amplifier

Filter

Limit

5m Chamber A

T144 8449B

Filter 1

FCC PART 24 Tx

f GHz	SA reading (dBm)	Ant. Pol. (H/V)	Distance (m)	Path Loss (dB)	Preamp (dB)	Filter (dB)	EIRP (dBm)	Limit (dBm)	Delta (dB)	Notes
<b>Low Ch. (1850.2 MHz)</b>										
3.7004	-59.6	H	3.0	45.0	36.8	1.0	-50.4	-13.0	-37.4	
5.5506	-59.0	H	3.0	49.9	36.3	1.0	-44.4	-13.0	-31.4	
9.2510	-66.3	H	3.0	55.2	37.0	1.0	-47.1	-13.0	-34.1	
3.7004	-57.4	V	3.0	44.9	36.8	1.0	-48.3	-13.0	-35.3	
5.5506	-55.1	V	3.0	49.3	36.3	1.0	-41.1	-13.0	-28.1	
9.2510	-67.1	V	3.0	54.2	37.0	1.0	-48.9	-13.0	-35.9	
<b>Mid Ch. (1880.0 MHz)</b>										
3.7600	-57.9	H	3.0	45.2	36.8	1.0	-48.5	-13.0	-35.5	
5.6400	-59.3	H	3.0	50.1	36.3	1.0	-44.5	-13.0	-31.5	
9.4000	-67.7	H	3.0	55.4	37.0	1.0	-48.3	-13.0	-35.3	
3.7600	-59.4	V	3.0	45.1	36.8	1.0	-50.1	-13.0	-37.1	
5.6400	-56.5	V	3.0	49.4	36.3	1.0	-42.4	-13.0	-29.4	
9.4000	-66.9	V	3.0	54.4	37.0	1.0	-48.5	-13.0	-35.5	
<b>Hi Ch. (1909.8 MHz)</b>										
3.8196	-56.4	H	3.0	45.3	36.7	1.0	-46.8	-13.0	-33.8	
5.7294	-60.1	H	3.0	50.2	36.3	1.0	-45.2	-13.0	-32.2	
9.5490	-66.5	H	3.0	55.6	37.1	1.0	-47.0	-13.0	-34.0	
3.8196	-59.4	V	3.0	45.2	36.7	1.0	-49.9	-13.0	-36.9	
5.7294	-57.5	V	3.0	49.5	36.3	1.0	-43.2	-13.0	-30.2	
9.5490	-65.9	V	3.0	54.6	37.1	1.0	-47.4	-13.0	-34.4	

Rev. 03.03.09

**EGPRS Mode (PCS Band)**

Compliance Certification Services Above 1GHz High Frequency Substitution Measurement										
<b>Company:</b>		INTERMEC TECHNOLOGISES CORP.								
<b>Project #:</b>		09U12493								
<b>Date:</b>		5/7/2009								
<b>Test Engineer:</b>		MENGISTU MEKURIA								
<b>Configuration:</b>		EUT ALONE								
<b>Mode:</b>		TX, EGPRS, PCS BAND								
<b>Chamber</b>		<b>Pre-amplifier</b>			<b>Filter</b>			<b>Limit</b>		
5m Chamber A		T144 8449B			Filter 1			FCC PART 24 Tx		
f GHz	SA reading (dBm)	Ant. Pol. (H/V)	Distance (m)	Path Loss (dB)	Preamp (dB)	Filter (dB)	EIRP (dBm)	Limit (dBm)	Delta (dB)	Notes
<b>Low Ch. (1850.2 MHz)</b>										
3.7004	-60.5	H	3.0	45.0	36.8	1.0	-51.3	-13.0	-38.3	
5.5506	-59.2	H	3.0	49.9	36.3	1.0	-44.6	-13.0	-31.6	
9.2510	-66.5	H	3.0	55.2	37.0	1.0	-47.2	-13.0	-34.2	
3.7004	-60.0	V	3.0	44.9	36.8	1.0	-50.9	-13.0	-37.9	
5.5506	-56.2	V	3.0	49.3	36.3	1.0	-42.2	-13.0	-29.2	
9.2510	-67.0	V	3.0	54.2	37.0	1.0	-48.8	-13.0	-35.8	
<b>Mid Ch. (1880.0 MHz)</b>										
3.7600	-57.5	H	3.0	45.2	36.8	1.0	-48.1	-13.0	-35.1	
5.6400	-59.6	H	3.0	50.1	36.3	1.0	-44.8	-13.0	-31.8	
9.4000	-67.6	H	3.0	55.4	37.0	1.0	-48.2	-13.0	-35.2	
3.7600	-57.7	V	3.0	45.1	36.8	1.0	-48.4	-13.0	-35.4	
5.6400	-56.9	V	3.0	49.4	36.3	1.0	-42.8	-13.0	-29.8	
9.4000	-67.0	V	3.0	54.4	37.0	1.0	-48.6	-13.0	-35.6	
<b>Hi Ch. (1909.8 MHz)</b>										
3.8196	-57.9	H	3.0	45.3	36.7	1.0	-48.3	-13.0	-35.3	
5.7294	-60.7	H	3.0	50.2	36.3	1.0	-45.7	-13.0	-32.7	
9.5490	-65.0	H	3.0	55.6	37.1	1.0	-45.5	-13.0	-32.5	
3.8196	-60.4	V	3.0	45.2	36.7	1.0	-50.9	-13.0	-37.9	
5.7294	-58.7	V	3.0	49.5	36.3	1.0	-44.5	-13.0	-31.5	
9.5490	-64.4	V	3.0	54.6	37.1	1.0	-45.8	-13.0	-32.8	
Rev. 03.03.09										

**UMTS REL 99 Mode (PCS Band)**

**Compliance Certification Services**  
**Above 1GHz High Frequency Substitution Measurement**

**Company:** INTERMEC TECHNOLOGISES CORP.  
**Project #:** 09U12493  
**Date:** 5/12/2009  
**Test Engineer:** MENGISTU MEKURIA  
**Configuration:** EUT ALONE  
**Mode:** TX, WCDMA, PCS BAND

Chamber

Pre-amplifier

Filter

Limit

5m Chamber A

T144 8449B

Filter 1

FCC PART 24 Tx

f GHz	SA reading (dBm)	Ant. Pol. (H/V)	Distance (m)	Path Loss (dB)	Preamp (dB)	Filter (dB)	EIRP (dBm)	Limit (dBm)	Delta (dB)	Notes
<b>Low Ch. (1852.4 MHz)</b>										
3.7052	-60.2	H	3.0	45.0	36.8	1.0	-51.0	-13.0	-38.0	
5.5578	-62.5	H	3.0	50.0	36.3	1.0	-47.8	-13.0	-34.8	
7.4104	-61.7	H	3.0	52.9	36.6	1.0	-44.4	-13.0	-31.4	
3.7052	-62.7	V	3.0	44.9	36.8	1.0	-53.6	-13.0	-40.6	
5.5578	-63.6	V	3.0	49.3	36.3	1.0	-49.6	-13.0	-36.6	
7.4104	-60.2	V	3.0	51.8	36.6	1.0	-43.9	-13.0	-30.9	
<b>Mid Ch. (1880.0 MHz)</b>										
3.7600	-59.2	H	3.0	45.2	36.8	1.0	-49.8	-13.0	-36.8	
5.6400	-63.5	H	3.0	50.1	36.3	1.0	-48.7	-13.0	-35.7	
7.5200	-61.7	H	3.0	53.1	36.6	1.0	-44.2	-13.0	-31.2	
3.7600	-60.7	V	3.0	45.1	36.8	1.0	-51.5	-13.0	-38.5	
5.6400	-62.6	V	3.0	49.4	36.3	1.0	-48.5	-13.0	-35.5	
7.5200	-62.2	V	3.0	52.0	36.6	1.0	-45.8	-13.0	-32.8	
<b>Hi Ch. (1907.6 MHz)</b>										
7.6304	-59.2	H	3.0	53.2	36.6	1.0	-41.6	-13.0	-28.6	
9.5380	-62.5	H	3.0	55.6	37.1	1.0	-42.9	-13.0	-29.9	
7.6304	-58.7	V	3.0	52.1	36.6	1.0	-42.2	-13.0	-29.2	
9.5380	-59.7	V	3.0	54.6	37.1	1.0	-41.2	-13.0	-28.2	
11.4456	-62.6	V	3.0	56.7	36.8	1.0	-41.7	-13.0	-28.7	
9.5490	-61.2	V	3.0	54.6	37.1	1.0	-42.7	-13.0	-29.7	

Rev. 03.03.09

**UMTS REL 6 HSDPA Subtest 2 Mode (PCS Band)**

**Compliance Certification Services**  
**Above 1GHz High Frequency Substitution Measurement**

**Company:** INTERMEC TECHNOLOGISES CORP.  
**Project #:** 09U12493  
**Date:** 5/12/2009  
**Test Engineer:** MENGISTU MEKURIA  
**Configuration:** EUT ALONE  
**Mode:** TX, HSDPA, PCS BAND

Chamber

Pre-amplifier

Filter

Limit

5m Chamber A

T144 8449B

Filter 1

FCC PART 24 Tx

f GHz	SA reading (dBm)	Ant. Pol. (H/V)	Distance (m)	Path Loss (dB)	Preamp (dB)	Filter (dB)	EIRP (dBm)	Limit (dBm)	Delta (dB)	Notes
<b>Low Ch. (1852.4 MHz)</b>										
3.7052	-58.1	H	3.0	45.0	36.8	1.0	-48.9	-13.0	-35.9	
5.5578	-60.3	H	3.0	50.0	36.3	1.0	-45.6	-13.0	-32.6	
7.4104	-59.8	H	3.0	52.9	36.6	1.0	-42.4	-13.0	-29.4	
3.7052	-61.4	V	3.0	44.9	36.8	1.0	-52.3	-13.0	-39.3	
5.5578	-61.6	V	3.0	49.3	36.3	1.0	-47.6	-13.0	-34.6	
7.4104	-69.0	V	3.0	51.8	36.6	1.0	-52.7	-13.0	-39.7	
<b>Mid Ch. (1880.0 MHz)</b>										
3.7600	-58.0	H	3.0	45.2	36.8	1.0	-48.6	-13.0	-35.6	
5.6400	-60.5	H	3.0	50.1	36.3	1.0	-45.7	-13.0	-32.7	
7.5200	-59.5	H	3.0	53.1	36.6	1.0	-42.0	-13.0	-29.0	
3.7600	-58.9	V	3.0	45.1	36.8	1.0	-49.7	-13.0	-36.7	
5.6400	-62.1	V	3.0	49.4	36.3	1.0	-48.0	-13.0	-35.0	
7.5200	-60.5	V	3.0	52.0	36.6	1.0	-44.1	-13.0	-31.1	
<b>Hi Ch. (1907.6 MHz)</b>										
7.6304	-57.9	H	3.0	53.2	36.6	1.0	-40.3	-13.0	-27.3	
9.5380	-61.5	H	3.0	55.6	37.1	1.0	-41.9	-13.0	-28.9	
7.6304	-57.1	V	3.0	52.1	36.6	1.0	-40.6	-13.0	-27.6	
9.5380	-58.4	V	3.0	54.6	37.1	1.0	-39.9	-13.0	-26.9	
11.4456	-61.0	V	3.0	56.7	36.8	1.0	-40.1	-13.0	-27.1	
9.5490	-59.4	V	3.0	54.6	37.1	1.0	-40.9	-13.0	-27.9	

Rev. 03.03.09

### 12.3. RECEIVER SPURIOUS EMISSIONS

#### RULE PART(S)

FCC: N/A

IC: RSS-132, 4.6; RSS-133, 6.6, RSS-Gen

#### LIMIT

RSS-Gen 6 (a) - If a radiated measurement is made, all spurious emissions shall comply with the limits of Table 1.

Table 1 - Spurious Emission Limits for Receivers:

Spurious Frequency (MHz)	Field Strength(microvolt/m at 3 meters)
30 - 88	100
88 - 216	150
216 - 960	200
Above 960	500

#### TEST PROCEDURE

RSS-Gen 4.10 - The search for spurious emissions shall be from the lowest frequency internally generated or used in the receiver (e.g. local oscillator, intermediate or carrier frequency), or 30 MHz, whichever is the higher, to at least 3 times the highest tuneable or local oscillator frequency, whichever is the higher, without exceeding 40 GHz.

#### RESULTS

See the following pages.



**RECEIVER SPURIOUS EMISSIONS FOR 30 TO 1000 MHz (CELL BAND)**

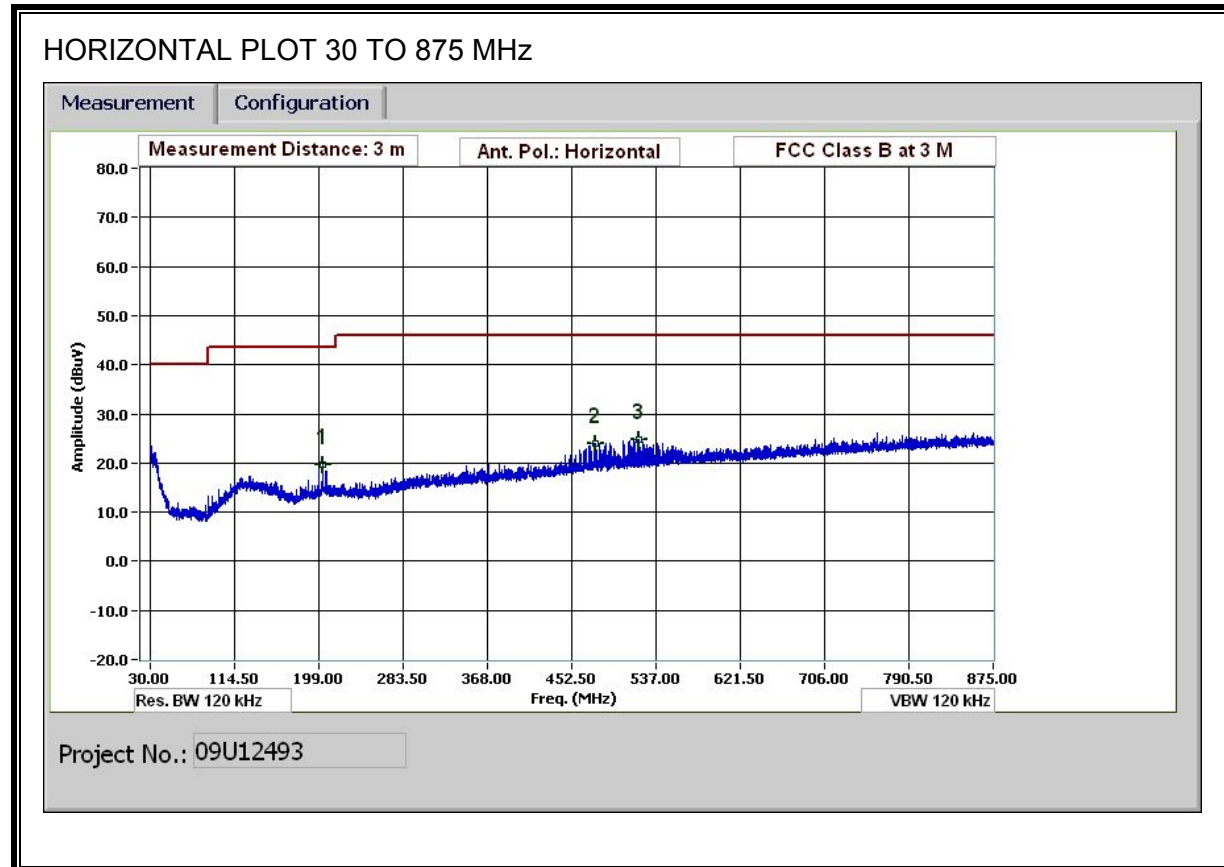

### HORIZONTAL PLOT 890 TO 1000 MHz

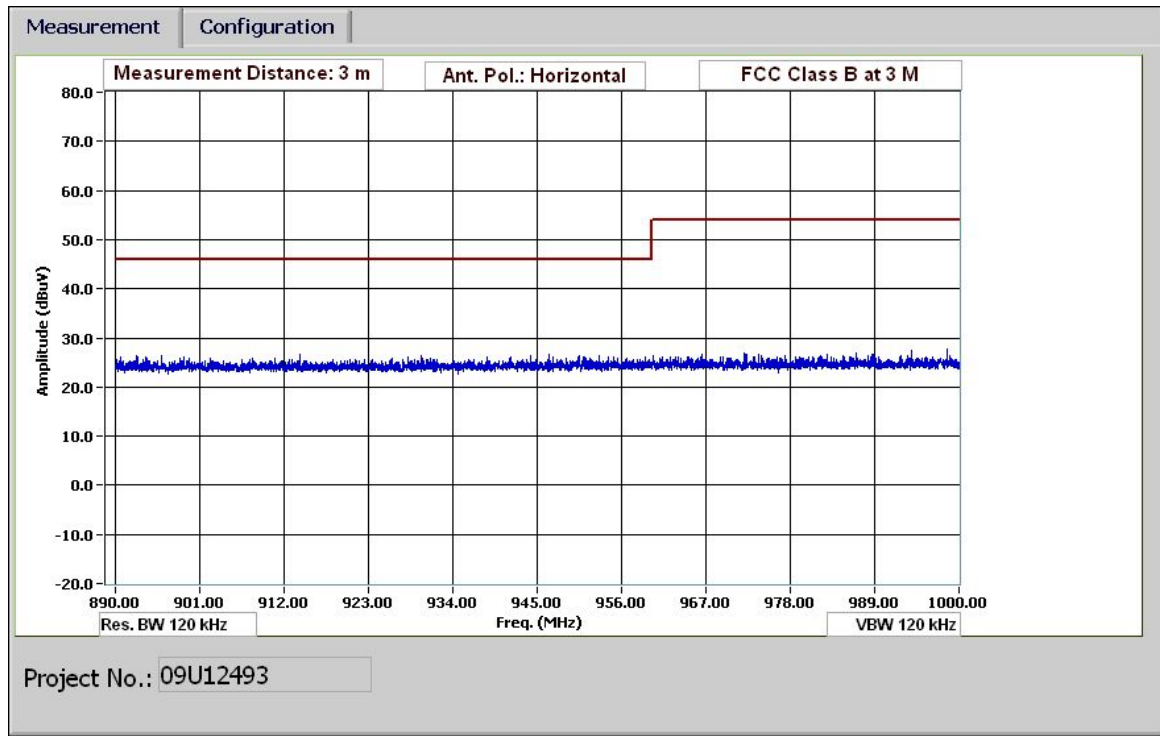

**RECEIVER SPURIOUS EMISSIONS FOR 30 TO 1000 MHz (CELL BAND)**

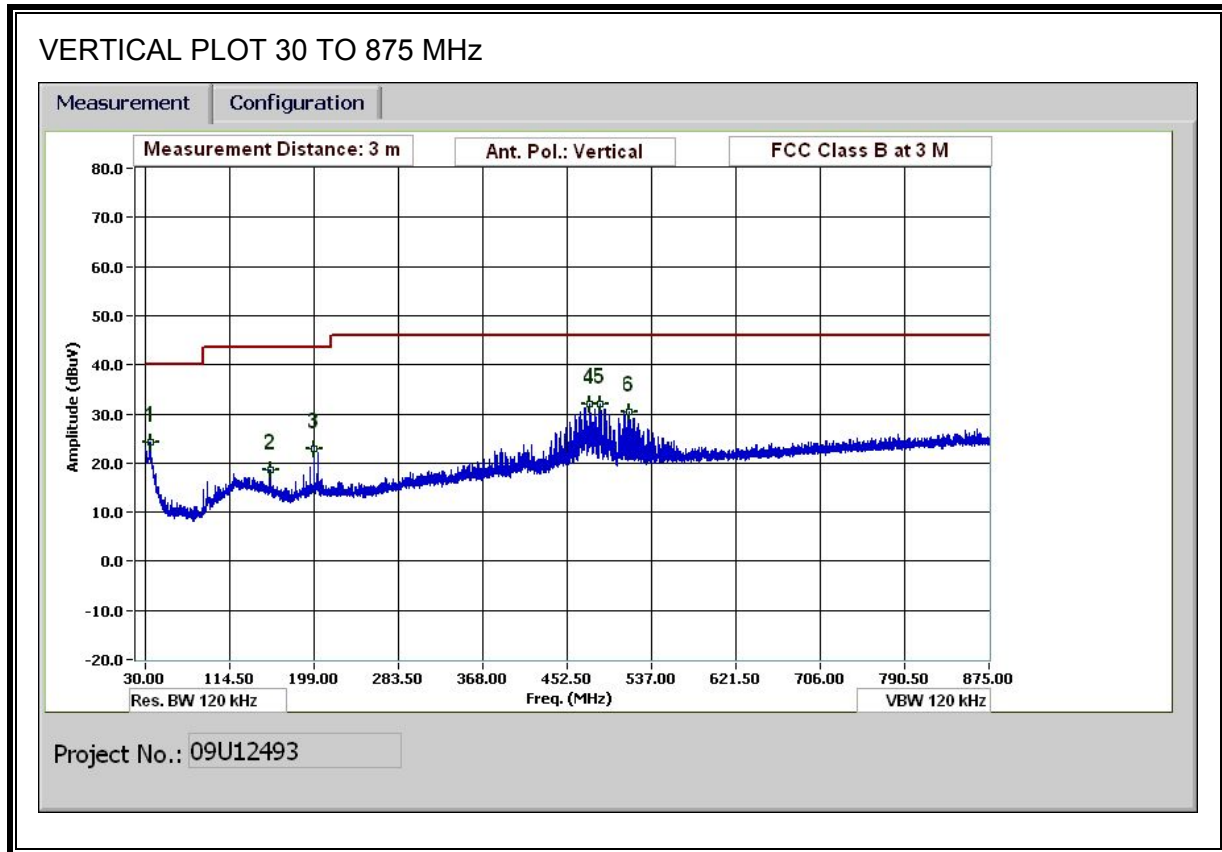

### VERTICAL PLOT 890 TO 1000 MHz

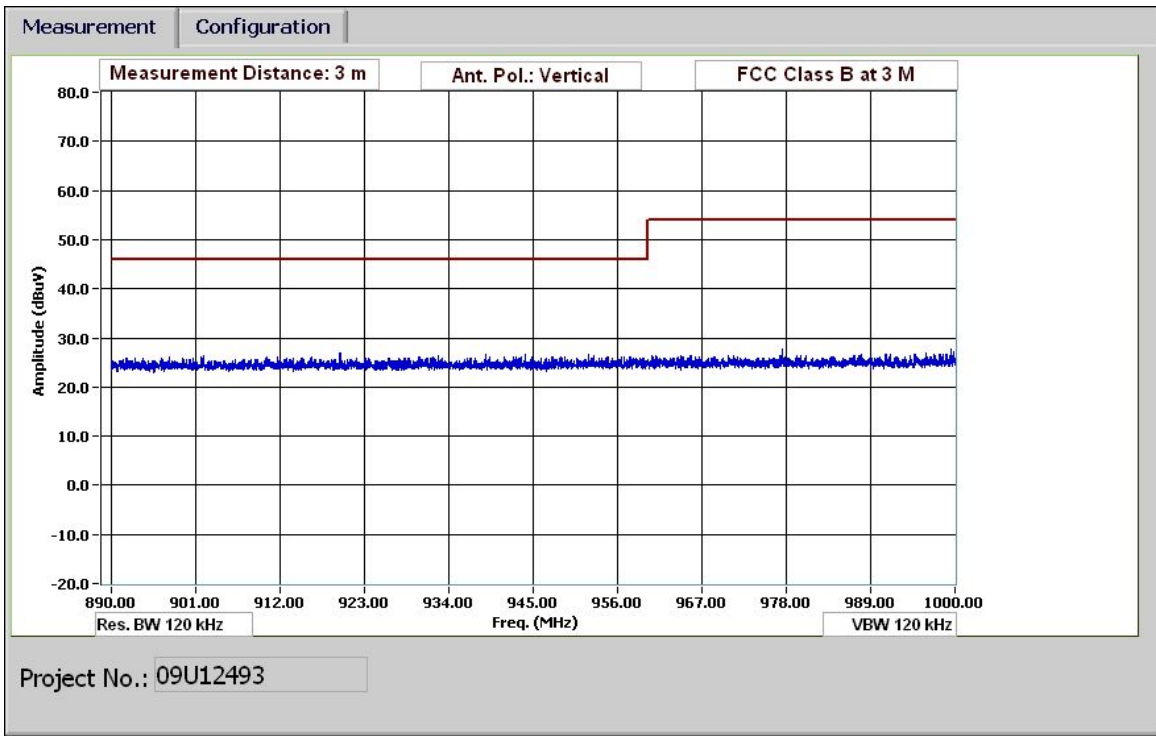

**HORIZONTAL AND VERTICAL DATA**

30-1000MHz Frequency Measurement													
Compliance Certification Services, Fremont 5m Chamber													
Test Engr:		MENGISTU MEKURIA											
Date:		05/11/09											
Project #:		09U12493											
Company:		INTERMEC TECHNOLOGISES CONRP.											
EUT Description:		EUT ALONE											
EUT M/N:		CN4e											
Test Target:		FCC CLASS B											
Mode Oper:		CELL RX MODE											
f	Measurement Frequency	Amp	Preamp Gain		Margin	Margin vs. Limit							
Dist	Distance to Antenna	D Corr	Distance Correct to 3 meters										
Read	Analyzer Reading	Filter	Filter Insert Loss										
AF	Antenna Factor	Corr.	Calculated Field Strength										
CL	Cable Loss	Limit	Field Strength Limit										
f	Dist	Read	AF	CL	Amp	D Corr	Filter	Corr.	Limit	Margin	Ant. Pol.	Det.	Notes
MHz	(m)	dBuV	dB/m	dB	dB	dB	dB	dBuV/m	dBuV/m	dB	V/H	P/A/QP	
202.701	3.0	34.7	12.0	1.3	28.2	0.0	0.0	19.8	43.5	-23.7	H	P	
475.656	3.0	33.6	16.3	2.0	27.9	0.0	0.0	24.0	46.0	-22.0	H	P	
519.249	3.0	33.3	17.1	2.1	27.8	0.0	0.0	24.7	46.0	-21.3	H	P	
34.704	3.0	33.9	18.1	0.5	28.4	0.0	0.0	24.1	40.0	-15.9	V	P	
154.821	3.0	33.7	12.2	1.1	28.3	0.0	0.0	18.7	43.5	-24.8	V	P	
199.042	3.0	37.9	11.9	1.2	28.2	0.0	0.0	22.8	43.5	-20.7	V	P	
475.447	3.0	41.5	16.3	2.0	27.9	0.0	0.0	31.9	46.0	-14.1	V	P	
484.960	3.0	41.5	16.5	2.0	27.9	0.0	0.0	32.1	46.0	-13.9	V	P	
514.022	3.0	39.2	17.0	2.1	27.8	0.0	0.0	30.4	46.0	-15.6	V	P	
Rev. 1.27.09													
Note: No other emissions were detected above the system noise floor.													

**RECEIVER SPURIOUS EMISSIONS FOR 30 TO 1000 MHz (PCS BAND)**

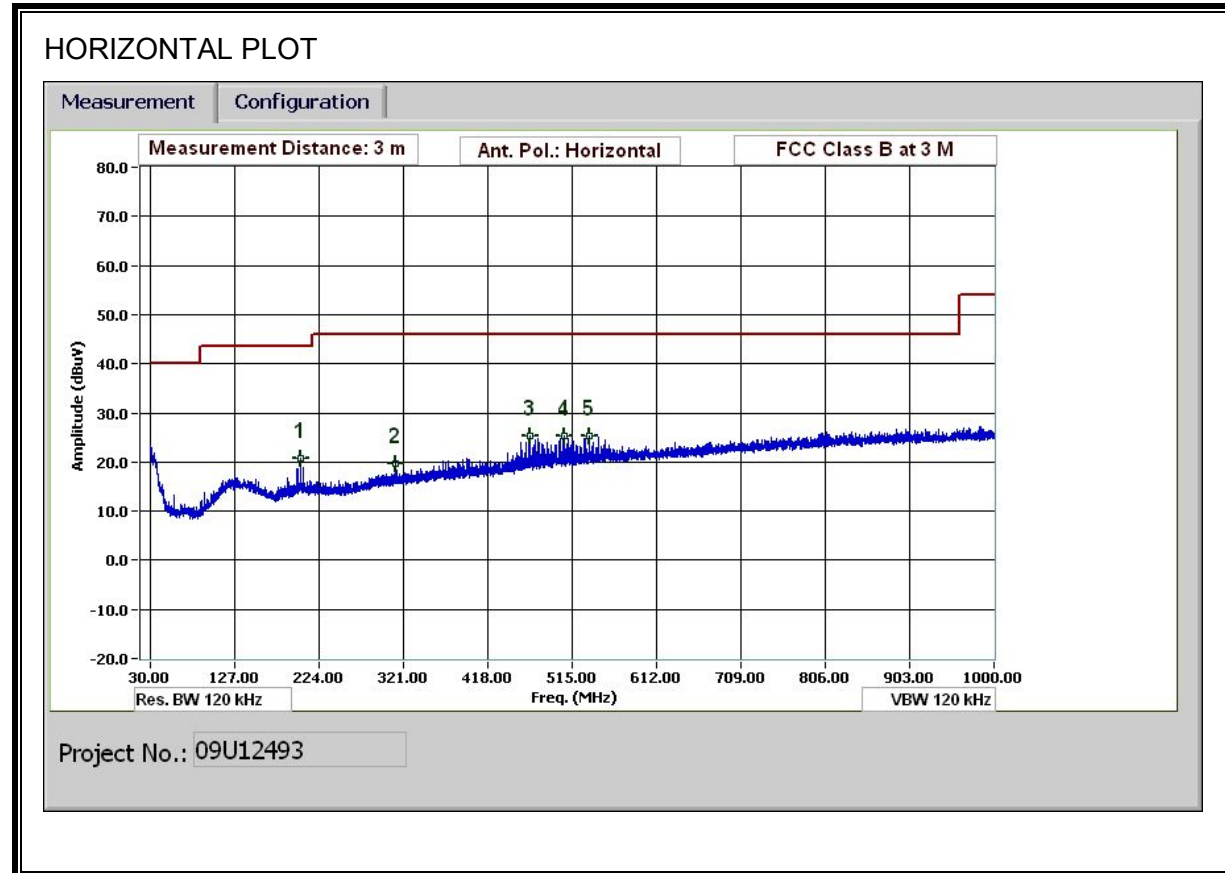

### VERTICAL PLOT

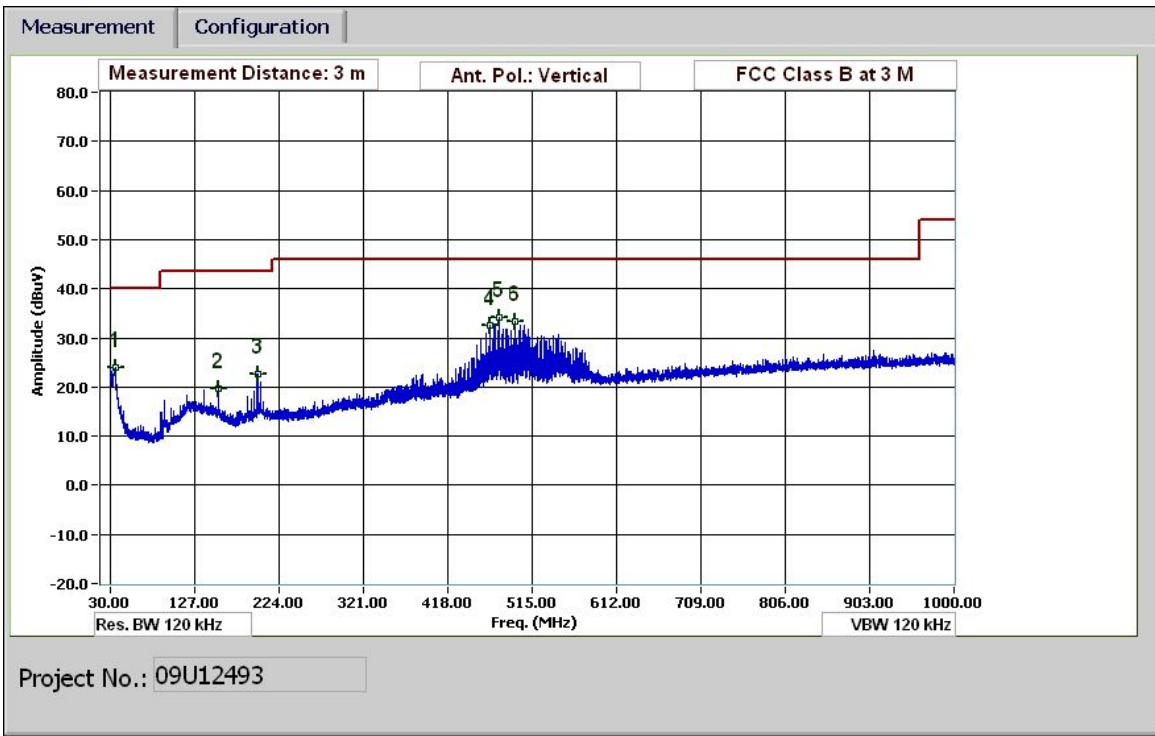

**HORIZONTAL AND VERTICAL DATA**

**30-1000MHz Frequency Measurement**

Compliance Certification Services, Fremont 5m Chamber

Test Engr: MENGISTU MEKURIA  
 Date: 05/11/09  
 Project #: 09U12493  
 Company: INTERMEC TECHNOLOGISES CONRP.  
 EUT Description: EUT ALONE  
 EUT M/N: CN4e  
 Test Target: FCC CLASS B  
 Mode Oper: PCS RX MODE

f	Measurement Frequency	Amp	Preamp Gain	Margin	Margin vs. Limit
Dist	Distance to Antenna	D Corr	Distance Correct to 3 meters		
Read	Analyzer Reading	Filter	Filter Insert Loss		
AF	Antenna Factor	Corr.	Calculated Field Strength		
CL	Cable Loss	Limit	Field Strength Limit		

f MHz	Dist (m)	Read dBuV	AF dB/m	CL dB	Amp dB	D Corr dB	Filter dB	Corr. dBuV/m	Limit dBuV/m	Margin dB	Ant. Pol V/H	Det. P/A/QP	Notes
202.807	3.0	35.7	12.0	1.3	28.2	0.0	0.0	20.7	43.5	-22.8	H	P	
311.532	3.0	32.6	13.6	1.5	28.1	0.0	0.0	19.6	46.0	-26.4	H	P	
466.938	3.0	35.1	16.1	2.0	27.9	0.0	0.0	25.2	46.0	-20.8	H	P	
505.460	3.0	34.3	16.8	2.0	27.8	0.0	0.0	25.4	46.0	-20.6	H	P	
534.621	3.0	33.7	17.3	2.1	27.7	0.0	0.0	25.4	46.0	-20.6	H	P	
35.520	3.0	34.2	17.5	0.6	28.4	0.0	0.0	23.9	40.0	-16.1	V	P	
154.805	3.0	34.7	12.2	1.1	28.3	0.0	0.0	19.7	43.5	-23.8	V	P	
199.087	3.0	37.7	11.9	1.2	28.2	0.0	0.0	22.7	43.5	-20.8	V	P	
466.698	3.0	42.5	16.1	2.0	27.9	0.0	0.0	32.6	46.0	-13.4	V	P	
476.898	3.0	43.7	16.3	2.0	27.9	0.0	0.0	34.1	46.0	-11.9	V	P	
495.859	3.0	42.4	16.7	2.0	27.8	0.0	0.0	33.3	46.0	-12.7	V	P	

Rev. 1.27.09

Note: No other emissions were detected above the system noise floor.

Note: no other emissions were found above 1GHz from the system noise.



## 12.4. POWER LINE CONDUCTED EMISSION

### LIMIT

#### RSS-Gen 7.2.2

Except when the requirements applicable to a given device state otherwise, for any licence-exempt radio communication device equipped to operate from the public utility AC power supply, either directly or indirectly, the radio frequency voltage that is conducted back onto the AC power lines in the frequency range of 0.15 MHz to 30 MHz shall not exceed the limits shown in Table 2. The tighter limit applies at the frequency range boundaries.

Table 2 – AC Power Lines Conducted Emission Limits

Frequency of Emission (MHz)	Conducted Limit (dBuV)	
	Quasi-peak	Average
0.15-0.5	66 to 56*	56 to 46*
0.5-5	56	46
5-30	60	50

\* Decreases with the logarithm of the frequency.

**RESULTS**

CONDUCTED EMISSIONS DATA (115VAC 60Hz)									
Freq.	Reading			Class	Limit	EN B	Margin		Remark
(MHz)	PK (dBuV)	QP (dBuV)	AV (dBuV)	(dB)	QP	AV	QP (dB)	AV (dB)	L1 / L2
0.51	35.84	--	27.73	0.00	56.00	46.00	-20.16	-18.27	L1
0.56	38.27	--	33.64	0.00	56.00	46.00	-17.73	-12.36	L1
0.62	38.01	--	33.21	0.00	56.00	46.00	-17.99	-12.79	L1
0.17	59.46	--	28.85	0.00	64.77	54.77	-5.31	-25.92	L2
0.25	54.12	--	24.69	0.00	61.72	51.72	-7.60	-27.03	L2
0.39	53.15	--	21.33	0.00	58.04	48.04	-4.89	-26.71	L2
6 Worst Data									

**LINE 1 RESULTS**

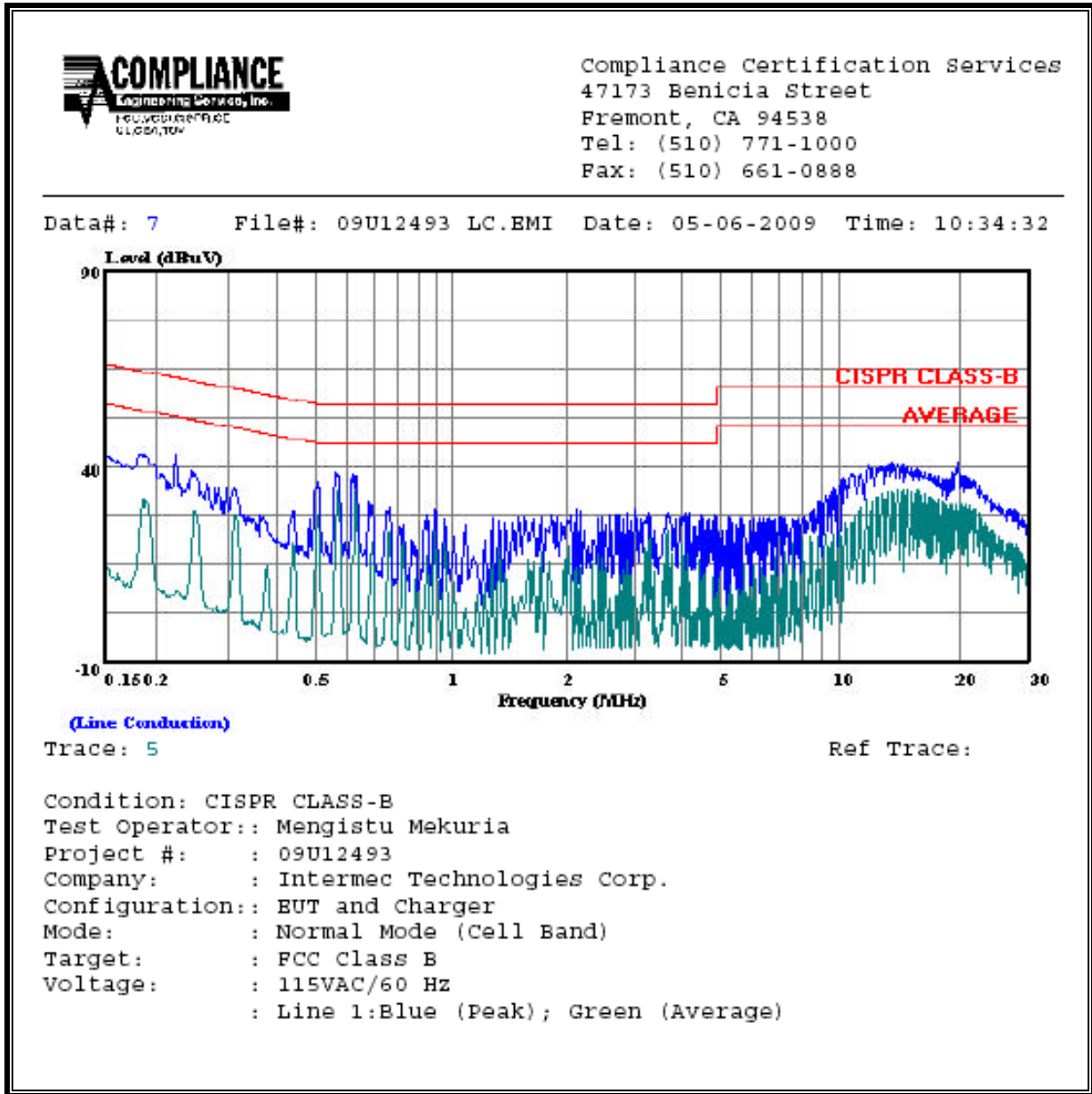

**LINE 2 RESULTS**

