

8

7

6

5

4

3

2

1

NOTES: (UNLESS OTHERWISE SPECIFIED)

- 1 TORQUE REQUIREMENTS FOR SCREWS:
A) 6 IN-LBS [6.91 KGF-CM] ± 20%
B) 12 IN-LBS [13.825 KGF-CM] ± 10%
C) 15 IN-LBS [17.282 KGF-CM] ± 10%
- 2 PLACE LABELS AS SHOWN. ENSURE TEXT IS READABLE.
- 3 FLAT OF SPROCKET SHAFT (PART OF ITEM 2) TO BE ORIENTATED TOWARDS BATTERY (ITEM 11).
- 4 ROUTE MOTOR ENCODER HARNESS (PART OF ITEM 2) THROUGH GAP OF PCBA HOLDER (PART OF ITEM 6) AND ATTACH ON HOOK OF PCBA HOLDER(PART OF ITEM 6) AS SHOWN.
- 5 ROUTE MOTOR POWER HARNESS (PART OF ITEM 2) AROUND PCBA HOLDER (ITEM 6) AND ATTACH ON HOOK OF PCBA HOLDER (PART OF ITEM 6) AS SHOWN.
- 6 ROUTE BATTERY HARNESS (ITEM 12) THROUGH GAP OF PCBA HOLDER (PART OF ITEM 6) AND ATTACH ON HOOK OF PCBA HOLDER (PART OF ITEM 6) AS SHOWN.
- 7 REMOVE ADHESIVE PROTECTION AND ADHERE FOAM PAD (ITEM 10) ON HOUSING (ITEM 3). ENSURE FOAM (ITEM 10) IS CENTERED ON FLAT SURFACE OF HOUSING (ITEM 3).
- 8 INSTALL HINGES OF ACCESS COVER(ITEM 5) ON PINS OF HOUSING (ITEM 3).
- 9 CONNECT OPEN WIRE HARNESSSES (PART OF ITEM 2 AND ITEM 12) TO PCBA (ITEM 1) AS SEEN IN INTERCONNECT DIAGRAM.
- 10 INSTALL PCBA (ITEM 1) UNDER SNAP HOOKS OF PCBA HOLDER (ITEM 6).
- 11 INSTALL SCREW (ITEM 15) IN THREADED INSERT OF PCBA HOLDER (PART OF ITEM 6) THROUGH HOLD OF ACCESS COVER (ITEM 5).
- 12 ROUTE ANTENNA (PART OF ITEM 1) THROUGH HOLE OF PCBA (ITEM 1) AND HOLE OF PCBA HOLDER (ITEM 6), SECURE AT BOTTOM OF MAIN HOUSING (ITEM 3) WITH TAPE (ITEM 21).

| REVISIONS | | | |
|-----------|---------------------|-----------|----------|
| REV | DESCRIPTION | DATE | APPROVED |
| X1 | INITIAL RELEASE | 3/9/2022 | |
| X2 | INC ECO-029154 - CB | 4/8/2022 | |
| X3 | INC ECO-09273 - LL | 7/15/2022 | |

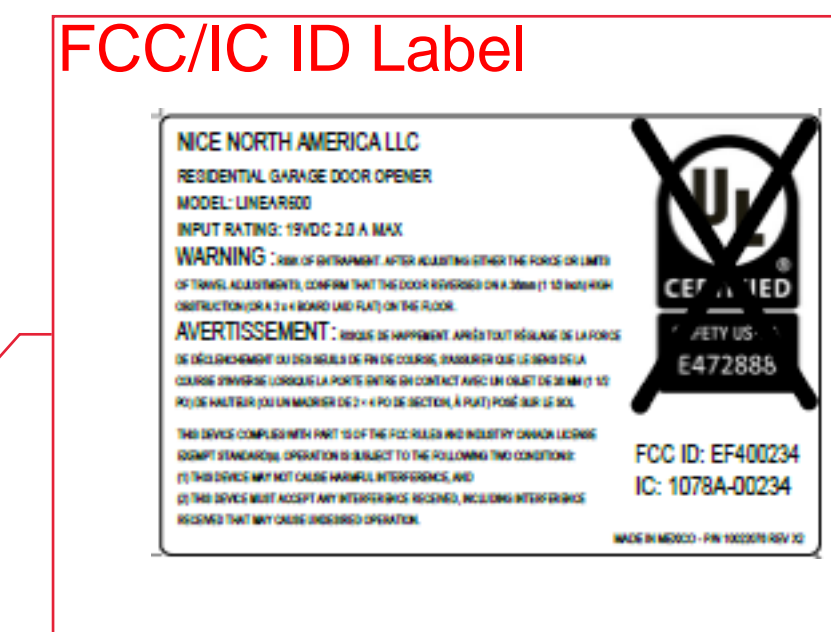
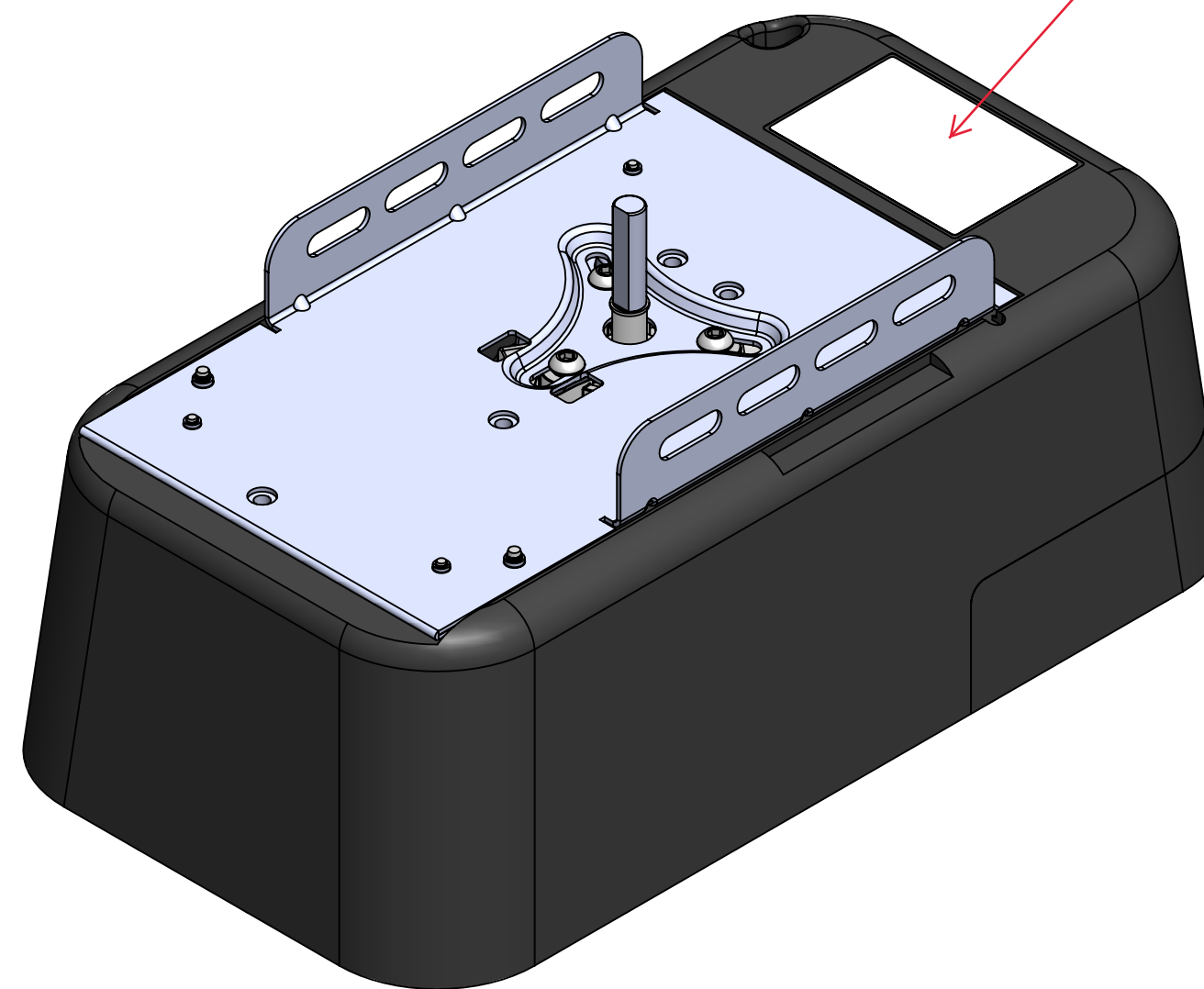

SEE SEPARATE PARTS LIST

THE INFORMATION CONTAINED IN THIS DRAWING IS THE SOLE PROPERTY OF NORTEK SECURITY & CONTROL. ANY REPRODUCTION IN PART OR AS A WHOLE WITHOUT WRITTEN PERMISSION OF NORTEK SECURITY & CONTROL IS PROHIBITED. © 2020 Nortek Security & Control LLC.

| | | | | | |
|--|--|-----------------------------|------------------|------------------------------------|---------------|
| UNLESS OTHERWISE NOTED ALL DIMENSIONS ARE INCHES (MM): | | PROJECT: | | NICE North America LLC | |
| TOLERANCES: DECIMALS: ANGLES: ± 0.5° .XX±.01 [.3] ROUNDNESS: ± .005 [.13] .XXX±.005 [.13] FLATNESS: ± .005 [.13] CONCENTRICITY: ± .005 [.13] | | CAD OPERATOR: C. BENNETT | DATE 3/9/2022 | TITLE: ASSY, MECH, GDO, LDCO600 | |
| MATERIAL: | | CHECKED: | DATE | SIZE: | |
| | | APPROVED: | DATE | DRAWING NO.: | REV.: |
| FINISH: | | APPROVED: | DATE | 10032972 | X3 |
| DO NOT SCALE DRAWING | | APPROVED: | DATE | SCALE: 5 : 8 | SHEET: 1 OF 3 |

8

7

6

5

4

3

2

1

NICE NORTH AMERICA LLC
RESIDENTIAL GARAGE DOOR OPENER
MODEL: LINEAR600
INPUT RATING: 19VDC 2.0 A MAX

WARNING : RISK OF ENTRAPMENT. AFTER ADJUSTING EITHER THE FORCE OR LIMITS OF TRAVEL ADJUSTMENTS, CONFIRM THAT THE DOOR REVERSES ON A 38mm (1 1/2 inch) HIGH OBSTRUCTION (OR A 2 x 4 BOARD LAID FLAT) ON THE FLOOR.

AVERTISSEMENT : RISQUE DE HAPPEMENT. APRÈS TOUT RÉGLAGE DE LA FORCE DE DÉCLENCHEMENT OU DES SEUILS DE FIN DE COURSE, S'ASSURER QUE LE SENS DE LA COURSE S'INVERSE LORSQUE LA PORTE ENTRE EN CONTACT AVEC UN OBJET DE 38 MM (1 1/2 PO) DE HAUTEUR (OU UN MADRIER DE 2 x 4 PO DE SECTION, À PLAT) POSÉ SUR LE SOL.

THIS DEVICE COMPLIES WITH PART 15 OF THE FCC RULES AND INDUSTRY CANADA LICENSE EXEMPT STANDARD(s). OPERATION IS SUBJECT TO THE FOLLOWING TWO CONDITIONS:

- (1) THIS DEVICE MAY NOT CAUSE HARMFUL INTERFERENCE, AND
- (2) THIS DEVICE MUST ACCEPT ANY INTERFERENCE RECEIVED, INCLUDING INTERFERENCE RECEIVED THAT MAY CAUSE UNDESIRED OPERATION.

MADE IN MEXICO - P/N 10022076 REV X1

