

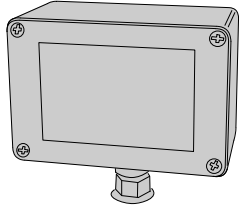

DTG

GATE SAFETY EDGE TRANSMITTER

Installation Instructions



DESCRIPTION

The DTG is part of Linear's Delta-3 product line and is compatible with all Delta-3 products. In a typical installation, the DTG is mounted on a motorized gate, door or barrier arm and wired to a standard exterior safety edge sensor which presents a closed circuit across the connecting wires when an object is hit during the closing of a gate. To insure full compatibility with all gate edge safety features, Linear recommends Miller gate edge sensors. If the edge sensor is pressed for a minimum of 1/8 second, the DTG transmits a message to the receiver to reverse the movement of the gate.

The DTG circuit board has been coated to prevent moisture damage and is mounted inside a weather resistant fiberglass box. The mounting box attaches to the gate through sealed interior mounting screws.



(800) 421-1587 • www.linearcorp.com

TYPICAL INSTALLATION

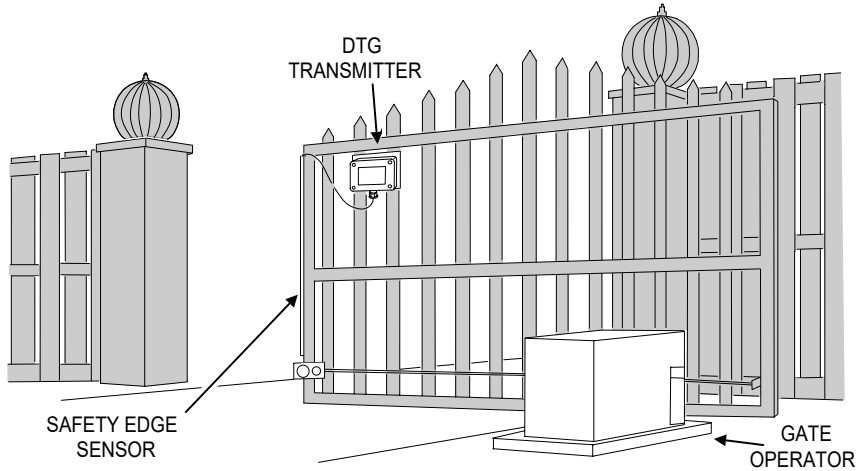

STEP 1 Remove Cover. Loosen the four screws on transmitter top and remove cover.

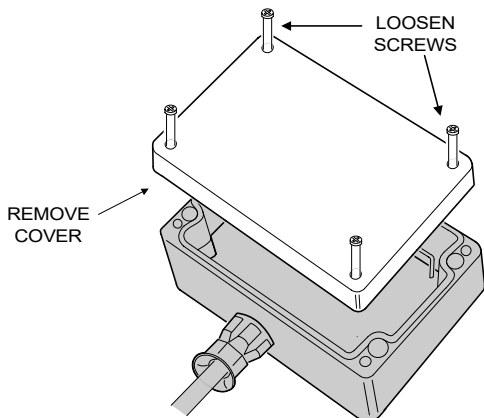

STEP 2 Locate Parts. Refer to diagram below for transmitter parts location and details.

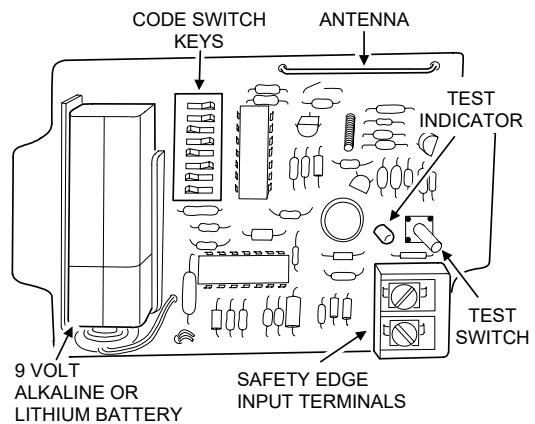

STEP 3 Mount Safety Edge. Mount safety edge according to manufacturer's instructions included with the product.

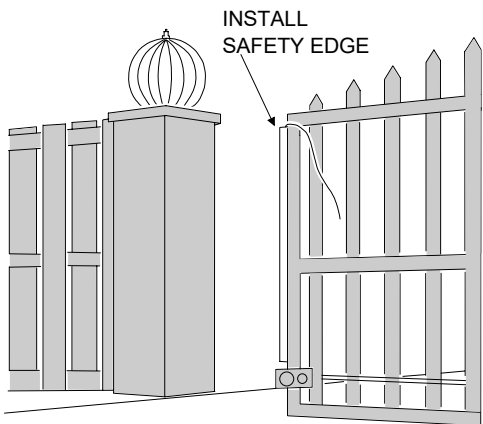

STEP 4 Mount DTG. Choose a location as high as possible on gate in a secure position. Use the template attached to mark the location for the transmitter. You may have to attach a metal or wood plate to mount transmitter. Use a 3/32" bit and drill holes. Attach DTG to gate using the four #6 self-tapping drill point screws.

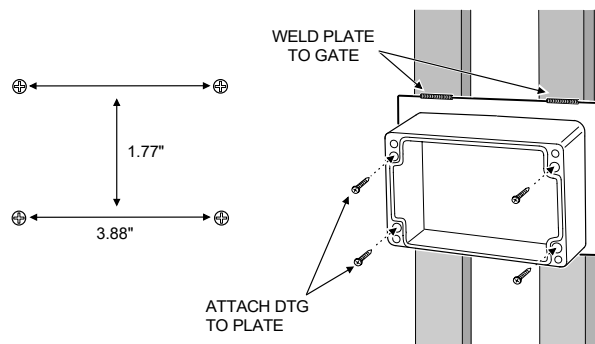

INSTR, INSTL, DTG
Linear P/N: 211906 Rev-D
Material: 20 Lb. Mead Bond
Size 8.500" x 11.000"
Ink: Black
Side 1 of 2
Scale: 1-1

STEP 5 Assemble Cable Grip. Unscrew the cable grip about 3/4 of the way and thread the safety edge cable through the cable entry on the transmitter.

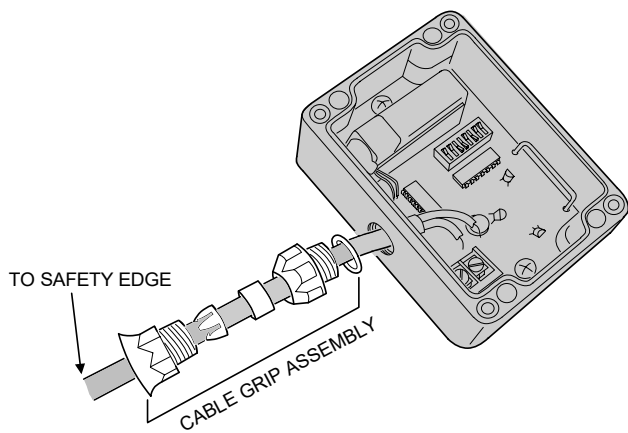

STEP 6 Attach Cable. Attach safety edge cable to terminals as shown. Tighten cable grip assembly using pliers to assure a water tight seal.

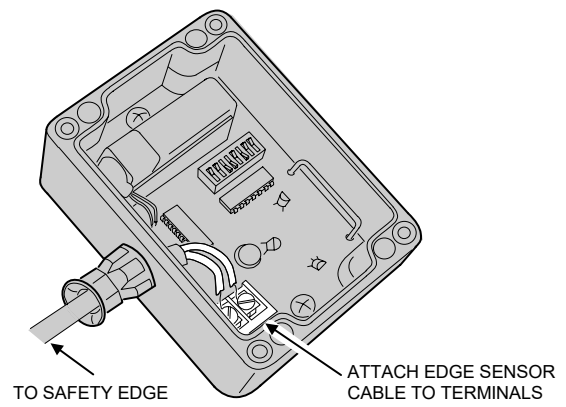

STEP 7 DTG Code Setting. To set a code, select any valid combination of ON and OFF positions for the switch keys numbered 1 - 8. Refer to receiver installation instructions to code receiver switches.

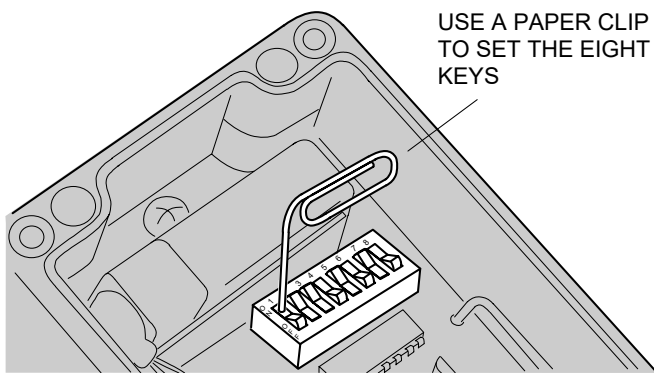

STEP 8 Test Safety Edge. Test safety edge connection by pressing the safety edge. The test indicator light should come on.

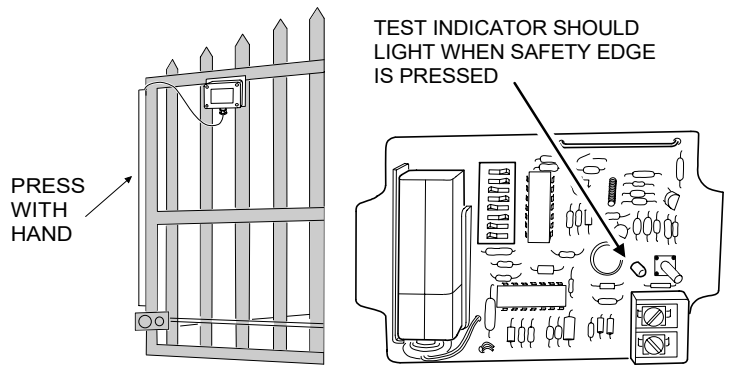

STEP 9 Wire Receiver. Wire receiver obstacle output to obstacle input on operator. Refer to operator and receiver wiring instructions.

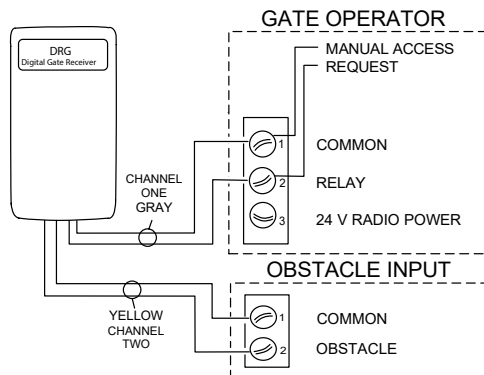

STEP 10 Test System. Activate the gate to close. As the gate is closing, press the safety edge with your hand. Gate should stop and reverse.

CAUTION! DO not stand in the path of the closing gate.

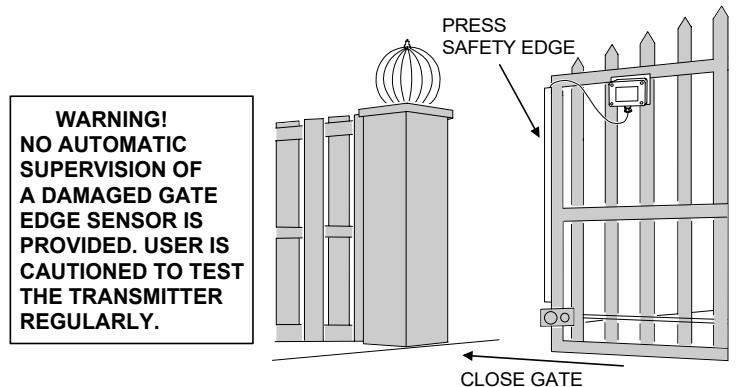

STEP 11 Replacing Batteries. If LED indicator fails to light when test button is pushed, replace with a 9 volt alkaline or lithium battery.

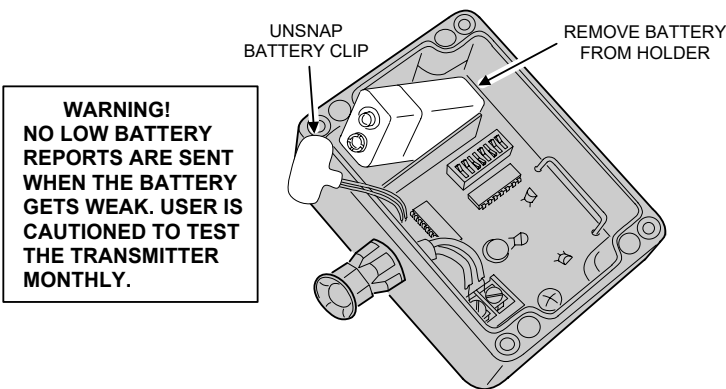

LIMITED WARRANTY

This Nortek Security & Control LLC product is warranted against defects in material and workmanship for twenty-four (24) months. This warranty extends only to wholesale customers who buy direct from Nortek or through Nortek's normal distribution channels. Nortek Security & Control LLC does not warrant this product to consumers. Consumers should inquire from their selling dealer as to the nature of the dealer's warranty, if any. There are no obligations or liabilities on the part of Nortek Security & Control LLC for consequential damages arising out of or in connection with use or performance of this product or other indirect damages with respect to loss of property, revenue, or profit, or cost of removal, installation, or reinstallation. All implied warranties, including implied warranties for merchantability and implied warranties for fitness, are valid only until the warranty expires. This Nortek Security & Control LLC Warranty is in lieu of all other warranties express or implied.

All products returned for warranty service require a Return Authorization Number (RA#). Contact Nortek Security & Control Returns at 1-855-546-3351 for an RA# and other important details.

FCC & IC Notice

This device complies with Part 15 of the FCC Rules and Industry Canada license exempt standard(s). Operation is subject to the following two conditions:

- 1) This device may not cause harmful interference, and
- 2) This device must accept any interference received, including interference received that may cause undesired operation.

Le présent appareil est conforme aux CNR d'Industrie Canada applicables aux appareils radio exempts de licence. L'exploitation est autorisée aux deux conditions suivantes:

- 1) (1) l'appareil ne doit pas produire de brouillage, et
- 2) (2) l'utilisateur de l'appareil doit accepter tout brouillage radioélectrique subi, même si le brouillage est susceptible d'en compromettre le fonctionnement.

WARNING: Changes or modifications not expressly approved by the manufacturer could void the user's authority to operate the equipment.

INSTR, INSTL, DTG
 Linear P/N: 211906 Rev-D
 Material: 20 Lb. Mead Bond
 Size 8.500" x 11.000"
 Ink: Black
 Side 2 of 2
 Scale: 1-1