

BATTERY LABEL LOCATION DETAIL
SCALE 2:1
(BACK COVER REMOVED FOR CLARITY)

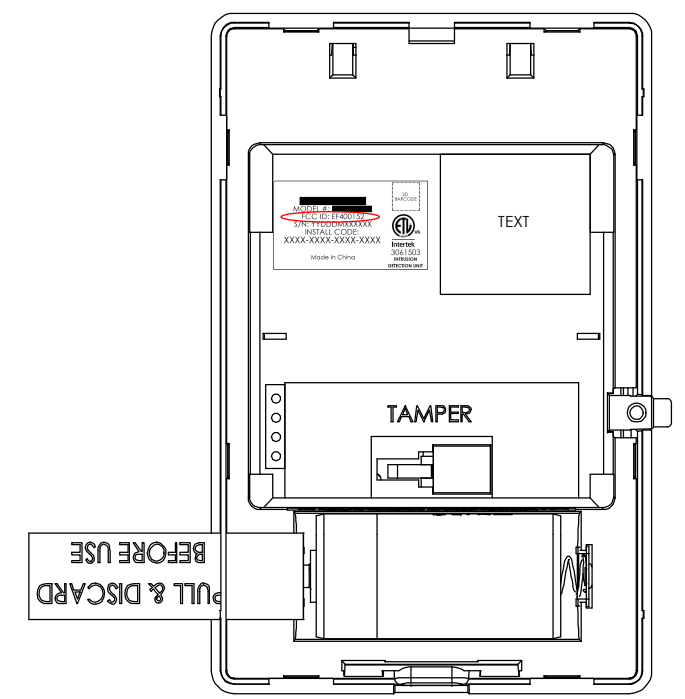

LABEL LOCATION DETAIL
SCALE 2:1
(BACK COVER REMOVED FOR CLARITY)

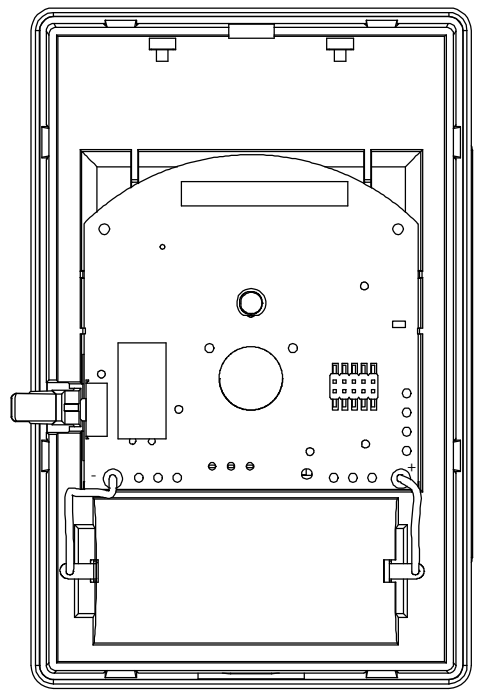

BATTERY TAB SOLDER DETAIL
(ITEMS NOT SHOWN FOR CLARITY)
SCALE 2:1

THE INFORMATION CONTAINED IN THIS DRAWING IS THE SOLE PROPERTY OF NORTEK SECURITY & CONTROL. ANY REPRODUCTION IN PART OR AS A WHOLE WITHOUT WRITTEN PERMISSION OF NORTEK SECURITY & CONTROL IS PROHIBITED.

UNLESS OTHERWISE NOTED ALL DIMENSIONS ARE INCHES [MM]:		PROJECT:		TITLE: ASSY, MECH, NOVA, PIR	
TOLERANCES: DECIMALS ANGLES: ± 0.5° XX±.01 [.3] ROUNDNESS: ±.005 [.13] XXX±.005 [.13] FLATNESS: ±.005 [.13] CONCENTRICITY: ±.005 [.13]		CAD OPERATOR: S. TRIMBLE	DATE: 3/1/2017		
MATERIAL:		CHECKED:	DATE:	DRAWING NO.: 10015623	
		APPROVED:	DATE:		
FINISH:		APPROVED:	DATE:		
		APPROVED:	DATE:		
DO NOT SCALE DRAWING		SCALE: 1:1	SHEET: 1 OF 1	REV: X3	

NOTES: (UNLESS OTHERWISE SPECIFIED)

- 1 MATERIAL: 3M 7113 REPOSITIONABLE PAPER LABEL OR EQUIVALENT, ADHESIVE BACKED.
- 2 RIBBON INK: BLACK, RICOH B110A-W3 OR EQUIVALENT.
- 3  QR CODE SHALL BE ENCODED WITH THE FOLLOWING VARIABLE DATA FIELDS :
 - INSTALLATION CODE: XXXXXXXXXXXXXXXX (OBTAINED FROM SERVER)
- 4 QR CODE MODEL 2 VERSION 4 (33 MODULES X 33 MODULES) WITH LOW CORRECTION. REFERENCE STANDARD ISO/IEC 18004:2015.
- 5 PRINTING TOLERANCE: ± .020 [.51].
- 6 PART SHALL BE RoHS COMPLIANT.

REVISIONS			
REV	DESCRIPTION	DATE	APPROVED
X1	INITIAL RELEASE		

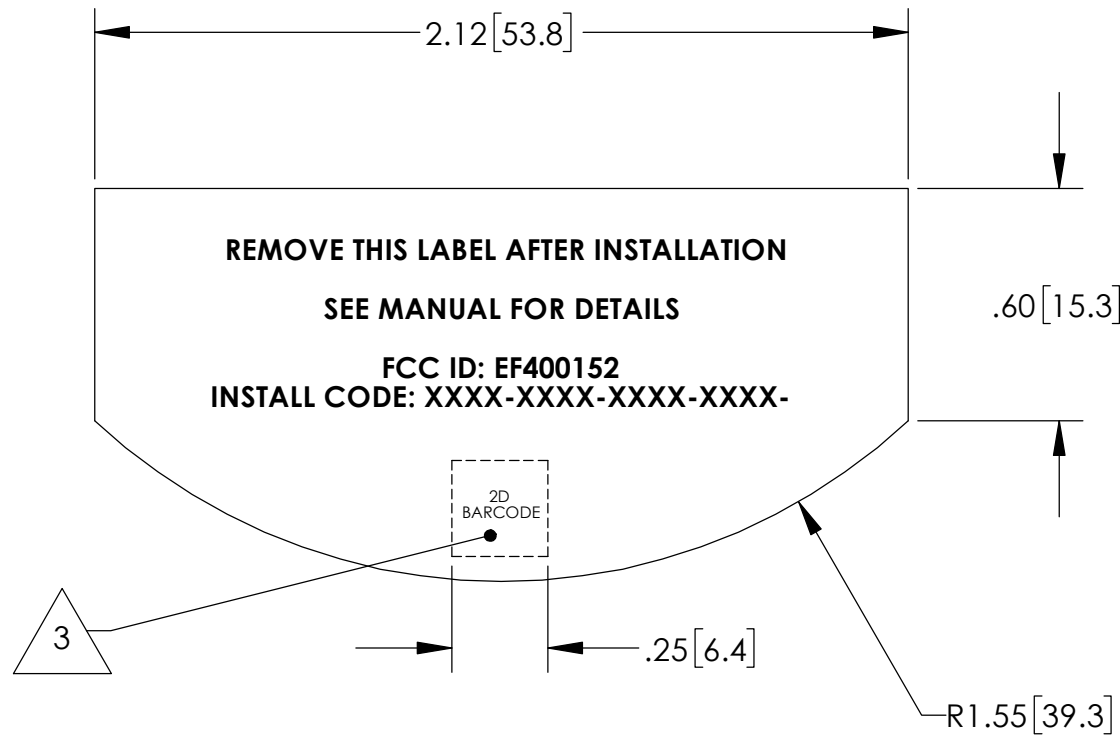

THE INFORMATION CONTAINED IN THIS DRAWING IS THE SOLE PROPERTY OF NORTEK SECURITY & CONTROL. ANY REPRODUCTION IN PART OR AS A WHOLE WITHOUT WRITTEN PERMISSION OF NORTEK SECURITY & CONTROL IS PROHIBITED.

UNLESS OTHERWISE NOTED ALL DIMENSIONS ARE INCHES [MM]:		PROJECT:			
TOLERANCES: DECIMALS .XX±.01 [.3] ANGLES: ±0.5° .XXX±.005 [.13] ROUNDNESS: ±.005 [.13] FLATNESS: ±.005 [.13] CONCENTRICITY: ±.005 [.13]		CAD OPERATOR: S. TRIMBLE			
MATERIAL: NOTED		CHECKED:		DATE:	TITLE: LABEL, REMOVABLE, ENROLL, QR, NOVA PIR DRAWING NO.: 10016160 REV.: X1
FINISH: NONE		APPROVED:		DATE:	
		APPROVED:		DATE:	
		SIZE: B	SCALE: 2:1		DO NOT SCALE DRAWING
		SHEET: 1 OF 1			

NOTES: (UNLESS OTHERWISE SPECIFIED)

- 1 MATERIAL: FASSON 2MIL HIGH GLOSS WHITE POLYESTER NTC/S33/BG50#WHT, OR EQUIVALENT, ADHESIVE BACKED.
- 2 RIBBON INK: BLACK, RICOH B110A-W3 OR EQUIVALENT.
- 3 DATA CONTAINED IN QR CODE TO BE LOGGED AND EMAILED AS FOLLOWS:
 - FILE FORMAT: TXT FILE
 - FILE NAMING: FG NUMBER (NO DASHES)_DATE AND TIME (YYYYMMDDHHMMSS).TXT
I.E. FADTPIR1_20170328074559
 - FILENAME TO BE UNIQUE.
 - FILE HEADER: FG NUMBER*SHIP DATE (MMDDYYYY)*PO NUMBER*LOT SIZE
I.E. H: F-ADT-PIR-1*03282017-123456-1000
 - ONLY ONE DATA ENTRY PER TEXT LINE.
 - EMAIL DATA FILE TO ADTQRDATA@NORTEKCONTROL.COM
- 4 QR CODE SHALL BE ENCODED WITH THE FOLLOWING VARIABLE DATA FIELDS :
 - SERIAL NUMBER: YYDDDMXXXXXX
YY=YEAR
DDD=MANUFACTURE DAY
M=MANUFACTURING FACILITY
XXXXXX=PRODUCTION SEQUENCE
SEE 10009912 FOR FORMAT.
I.E. 17101A123456
 - INSTALLATION CODE: XXXXXXXXXXXXXXXX (OBTAINED FROM SERVER)
- 5 QR CODE MODEL 2, VERSION 4 (33 MODULES X 33 MODULES) WITH LOW CORRECTION. REFERENCE STANDARD ISO/IEC 18004:2015.
- 6 PRINTING TOLERANCE: $\pm .020$ [.51].
- 7 PART SHALL BE RoHS COMPLIANT.

REVISIONS			
REV	DESCRIPTION	DATE	APPROVED
X1	INITIAL RELEASE		

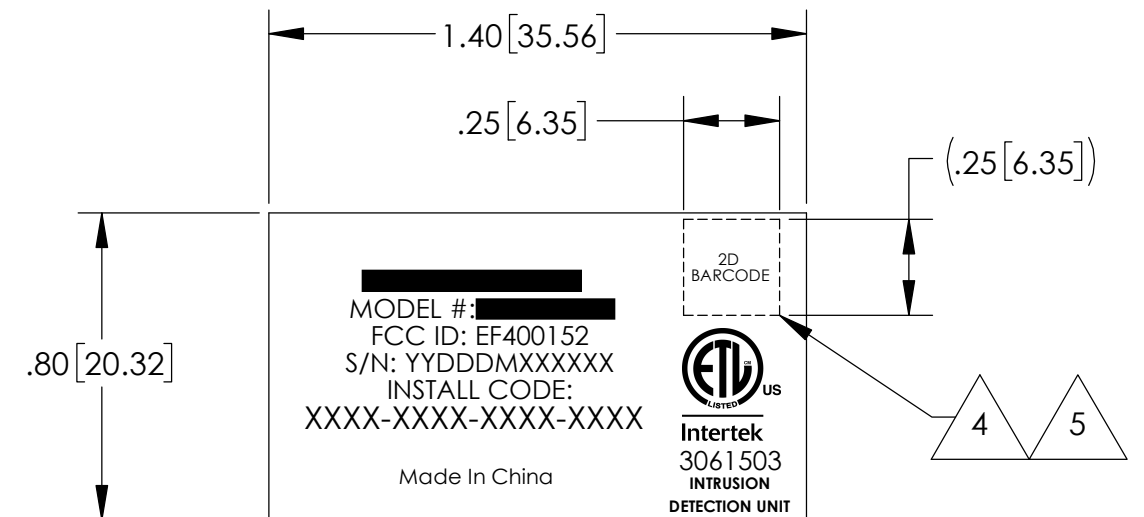

LABEL DETAIL

UNLESS OTHERWISE NOTED ALL DIMENSIONS ARE INCHES [MM]:		PROJECT:			
TOLERANCES: DECIMALS .XX±01 [.3] ANGLES: ±0.5° .XXX±020 [.51] ROUNDNESS: ±.005 [.13] FLATNESS: ±.005 [.13] CONCENTRICITY: ±.005 [.13]		CAD OPERATOR: S. TRIMBLE			
MATERIAL: NOTED		CHECKED: DATE:		DRAWING NO.: 10016162	
FINISH:		APPROVED: DATE:		REV.: X1	
		APPROVED: DATE:		SCALE: 2:1	
				DO NOT SCALE DRAWING	
				SHEET: 1 OF 1	