

8 7 6 5 4 3 2 1

NOTES: (UNLESS OTHERWISE SPECIFIED)
 1 ADHERE GASKET (ITEM 6) TO FRONT PANEL (ITEM 2) AS SHOWN.
 2 APPLY LABEL (ITEM 7) APPROXIMATELY WHERE SHOWN.

REVISIONS			
REV	DESCRIPTION	DATE	APPROVED
X1	INITIAL RELEASE	02/25/2014	
X2	ADD FCC LABEL	04/11/2014	
X3	CHG FCC LABEL POSITION	04/21/2014	

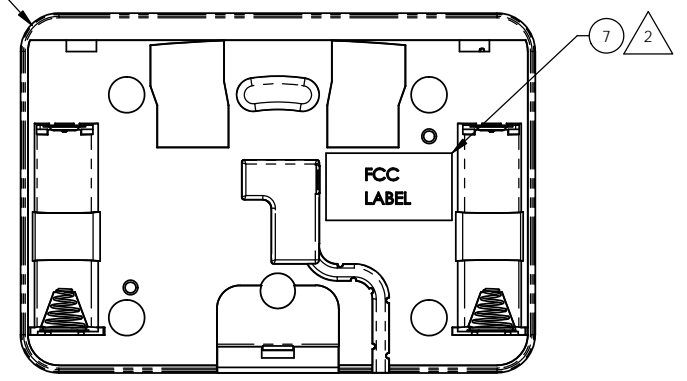
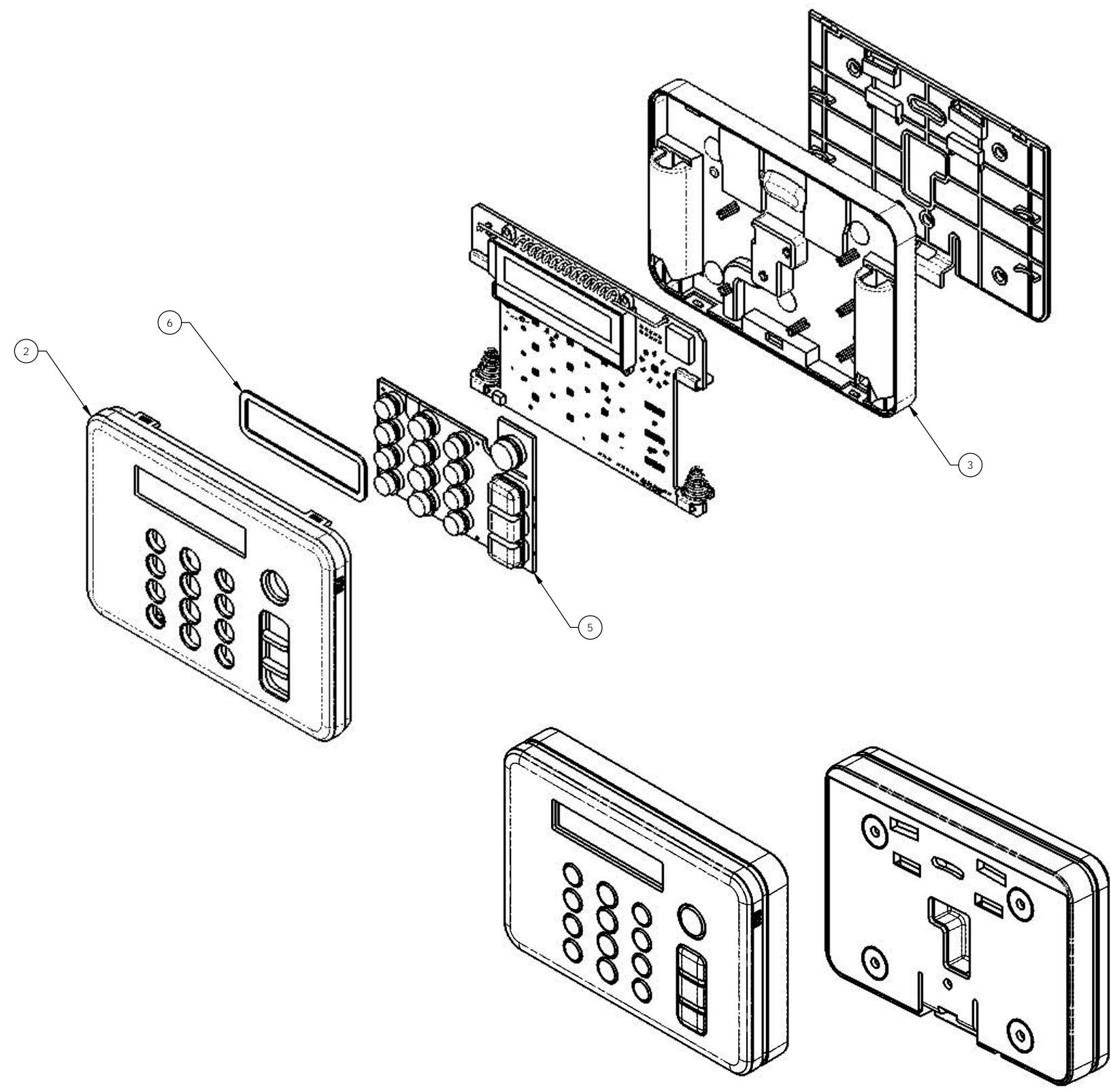

LABEL PLACEMENT DETAIL

SEE SEPARATE PARTS LIST

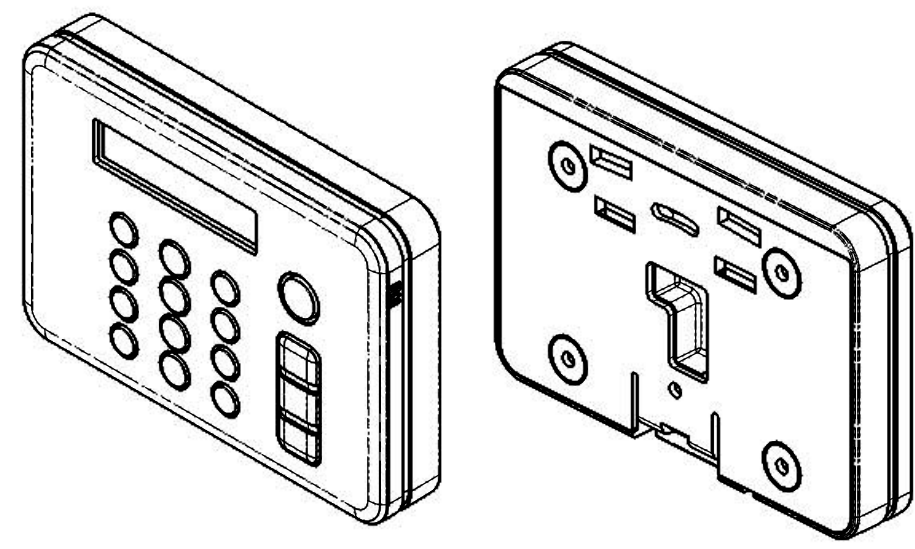

ASSEMBLED VIEW

UNLESS OTHERWISE NOTED ALL DIMENSIONS ARE INCHES (MM): TOLERANCES: DECIMALS ANGLES: ± 0.5° XX±.01 [.3] ROUNDNESS: ±.005 [.13] XXX±.005 [.13] FLATNESS: ±.005 [.13] CONCENTRICITY: ±.005 [.13]	PROJECT:		Linear	
	CAD OPERATOR:	DATE:		
	MATERIAL:	M. SHIN	2/25/2014	TITLE:
	FINISH:	CHECKED:	TBD	ASSY,MECH,KEYPAD,LIFE SHIELD
	DO NOT SCALE DRAWING	APPROVED:	TBD	SIZE: D
	APPROVED:	TBD	DRAWING NO.: 236171	REV.: X3
	APPROVED:	TBD	SCALE: NONE	SHEET: 1 OF 1

8 7 6 5 4 3 2 1