

ALPS Radio Module Specification for DECT using 2.4GHz ISM band

Model number	Function	Specification revision	Remarks
UGSA4X5□□A	Base Station	REV.4.1.2	

CONFIDENTIALITY NOTES:

This specification contains confidential information which shall not be provided to any third parties without agreement notice.

PRELIMINARY / CONFIDENTIAL

DECT 2.4G BS Rev.4.1.2
ALPS ELECTRIC CO., LTD.

Contents

1 PURPOSE AND SCOPE	4
2 STANDARD OPERATING CONDITIONS.....	4
2-1 OPERATING TEMPERATURE RANGE	4
2-2 STORAGE TEMPERATURE RANGE.....	4
2-3 SUPPLY VOLTAGE	4
2-4 SLOT OPERATION.....	4
2-5 REFERENCE OSCILLATOR.....	4
2-6 SPECIFICATION GUARANTEE	4
3 MECHANICAL CHARACTERISTICS.....	5
3-1 ASPECT	5
3-2 DIMENSIONS	5
3-3 WEIGHT	5
4 ANTENNA CONNECTION.....	5
5 GENERAL ELECTRICAL CHARACTERISTICS.....	5
5-1 COMMON SPECIFICATIONS	5
5-1-1 <i>Operating Frequency</i>	5
5-1-2 <i>Carrier Spacing</i>	5
5-1-3 <i>Duplexing</i>	5
5-1-4 <i>Bit Rate</i>	5
5-1-5 <i>Modulation Method</i>	5
5-2 TX SPECIFICATIONS.....	5
5-2-1 <i>TX Frequency Accuracy</i>	5
5-2-2 <i>Rate of Change the Center frequency</i>	5
5-1-3 <i>PLL Lockup time</i>	5
5-2-4 <i>Normal Transmitter Power</i>	5
5-2-5 <i>Modulation Polarity</i>	6
5-2-6 <i>Nominal Peak Deviation</i>	6
5-2-7 <i>Deviation Limit</i>	6
5-2-8 <i>Unwanted RF Power Emission</i>	7
5-3 RX SPECIFICATION.....	8
5-3-1 <i>Input Sensitivity</i>	8
5-3-2 <i>Radio Receiver Reference Bit Error Rate</i>	8
5-3-3 <i>Radio Receiver interference performance</i>	8
5-3-4 <i>Radio Receiver Blocking (To be checked)</i>	8
5-3-5 <i>Receiver Intermodulation Performance</i>	9
5-3-6 <i>Conducted Spurious Emissions when not allocated a transmit channel</i>	9
5-3-7 <i>RSSI</i>	9
5-3-8 <i>RX DATA DC output level</i>	9
5-3-9 <i>Demod. Out Polarity</i>	9
5-4 CURRENT CONSUMPTION	10
5-4-1 <i>in Transmit slot : T.B.D mA MAX.</i>	10
5-4-2 <i>in TX blind slot : T.B.D mA MAX.</i>	10
5-4-3 <i>in Receive slot : T.B.D mA MAX.</i>	10
5-4-4 <i>in RX blind slot : T.B.D mA MAX.</i>	10
5-5 COLD START UP TIME	10
6-1 TEST METHOD	11
6-1-1 <i>High Temperature Test : (No power applied)</i>	11
6-1-2 <i>High Temperature Test : (Power applied)</i>	11

PRELIMINARY / CONFIDENTIALDECT 2.4G BS Rev.4.1.2
ALPS ELECTRIC CO., LTD.

6-1-3 Temperature Test : 11
 6-1-4 Temperature Shock : 11
 6-1-5 Humidity Test : 11
 6-1-6 Vibration Test : 11
 6-1-7 Drop Test : 11
 6-1-8 Resistance to reflow soldering: 12
 6-2 TABLE-1 12

7 LIFE SUPPORT APPLICATIONS.....12

9 ELECTRICAL CHARACTERISTICS14

10 APPENDIX15

10-1 PLL FREQUENCY AND CONTROL DATA TABLE 15
 10-1-1 The Programmable Reference Divider 15
 10-1-2 The Programmable Function Resister 15
 10-1-3 The Programmable Divider (PLL frequency table) 15
 10-1-4 Initialization Sequence 19
 10-1-5 Change of Channel 19
 10-1-6 Timing Chart (Please firstly send MSB.) 19
 10-2 EXAMPLE OF INTERFACE TIMING 20
 10-3 RECOMMENDED SOLDERING CONDITION 22
 10-3-1 Heating method 22
 10-3-2 Temperature measurement 22
 10-3-3 Solder condition 22
 10-3-4 Temperature profile 22

1 PURPOSE AND SCOPE

This document contains the specifications pertinent to 2.4GHz DECT radio module which comply with FCC CFR47 Part 15.33,109,205,209,247. It includes GENERAL MECHANICAL, ELECTRICAL REQUIREMENTS.

2 STANDARD OPERATING CONDITIONS

2-1 OPERATING TEMPERATURE RANGE

Nominal : +15 °C to +35 °C
Extreme : 0°C to +40°C

2-2 STORAGE TEMPERATURE RANGE

-25 °C to +75 °C

2-3 SUPPLY VOLTAGE

Nominal : +4.0 V
Extreme : +3.8 V ~ +4.2 V

2-4 SLOT OPERATION

The radio module shall be operated under one blind slot condition.

2-5 REFERENCE OSCILLATOR

The radio module does not include the reference oscillator, which shall be supplied externally. The all specification of frequency related items have been guaranteed based on ± 3 ppm accuracy over large extreme temperature.

2-6 SPECIFICATION GUARANTEE

The module could not be guaranteed in the case of removing after soldering due to any reason.

PRELIMINARY / CONFIDENTIAL

DECT 2.4G BS Rev.4.1.2
ALPS ELECTRIC CO., LTD.

3 MECHANICAL CHARACTERISTICS

3-1 ASPECT

There should not be contamination, scratches nor strains on body.

3-2 DIMENSIONS

Refer to assembly drawings.

3-3 WEIGHT

10 g TYP.

4 ANTENNA CONNECTION

Refer to assembly drawings.

5 GENERAL ELECTRICAL CHARACTERISTICS

5-1 COMMON SPECIFICATIONS

5-1-1 Operating Frequency

2400.439 MHz to 2483.383 MHz

5-1-2 Carrier Spacing

10.368/(21/2) MHz

5-1-3 Duplexing

TDD

5-1-4 Bit Rate

768kbps

5-1-5 Modulation Method

GFSK BbT = 0.5

5-2 TX SPECIFICATIONS

5-2-1 TX Frequency Accuracy

< Temp Extreme, Volt Extreme >
±75 kHz MAX.

5-2-2 Rate of Change the Center frequency

< Temp Nominal, Volt Nominal >
±23 kHz / slot MAX.(TENTATIVE)

5-2-3 PLL Lockup time

< Temp Extreme, Volt Nominal >
500usec MAX (within ±50 kHz) (TENTATIVE)

5-2-4 Normal Transmitter Power

< Temp Nominal, Volt Nominal >
+23 dBm ±3 dB TYP +30 dBm MAX (TENTATIVE)

PRELIMINARY / CONFIDENTIAL

DECT 2.4G BS Rev.4.1.2
ALPS ELECTRIC CO., LTD.

5-2-5 Modulation Polarity

Binary "HIGH" (V_{IH}) ---- $F_c - \Delta F$ Binary "LOW" (V_{IL}) ---- $F_c + \Delta F$

5-2-6 Nominal Peak Deviation

< Temp Nominal, Volt Nominal >

192kHz TYP. (TENTATIVE)

5-2-7 Deviation Limit

< Temp Nominal, Volt Nominal >

(These limits apply equally to positive and negative deviations)

CASE A: Apply to the transmission of repeating binary sequence of four "1s" and "0s".

Peak deviation 171 kHz MIN. (TENTATIVE)

271 kHz MAX. (TENTATIVE)

CASE B: all other binary sequence.

Peak deviation 136 kHz MIN. (TENTATIVE)

271 kHz MAX. (TENTATIVE)

5-2-8 Unwanted RF Power Emission

< Temp Nominal, Volt Nominal >

5-2-8-1 20 dB Bandwidth

The maximum 20 dB band width is 1 MHz.

5-2-8-2 Conducted spurious emissions when allocated a transmit channel

In any 100 kHz bandwidth outside the frequency band, the radio frequency power shall be at least 20 dB below that in the 100 kHz bandwidth within the band that contains the highest level of the desired power, based on either an RF conducted measurement.

The emission which fall the restricted bands described in FCC Part15.205 shall be less than the value described in FCC Part15.209.

PRELIMINARY / CONFIDENTIAL

DECT 2.4G BS Rev.4.1.2
ALPS ELECTRIC CO., LTD.

5-3 RX SPECIFICATION

5-3-1 Input Sensitivity

BER shall be less than 0.001 in the D field at the following conditions.

< Temp Nominal, Volt Nominal >
 Carrier level : -89 dBm MAX.

This limit shall be met for DECT transmitted frequency error of ±75 kHz.
 This shall be met in time division duplex mode.

5-3-2 Radio Receiver Reference Bit Error Rate

< Temp Nominal, Volt Nominal >
 BER in the D field shall be less than 0.00001 at the following conditions.
 Carrier Signal Level: -73 dBm

5-3-3 Radio Receiver interference performance

BER in the D field shall be less than 0.001 at the following conditions.
 Carrier Signal Level (Channel M) : -73 dBm
 Modulated Interference Signal Level (Channel Y) :

Interfere on RF channel "Y"	Interfere Signal level
Y=M	-85 dBm
Y=M±1	-76 dBm
Y=M±2	-47 dBm
Y=M±3,4	-39 dBm
Y=M±5	-33 dBm

All interference to be measured at center channel

5-3-4 Radio Receiver Blocking (To be checked)

< Temp Nominal, Volt Nominal >
 BER in the D field shall be less than 0.001 at the following conditions.
 Carrier Signal level : -80 dBm

Interference Signal Level :

Frequency(f)	Continuous sine wave carrier level
25 MHz ≤ f < 2299.2 MHz	-30 dBm
2299.2 MHz ≤ f < 2394.2MHz	-50 dBm
6MHz < f - fc	-60 dBm
2498.3 MHz < f ≤ 2584.3 MHz	-60 dBm
2584.3MHz < f ≤ 12.408GHz	-33 dBm

Concessions of Radio Receiver Blocking

If Radio Module fails to meet above requirements only due to maximum number frequencies in the case of the following conditions, the Radio Module shall be deemed to meet the requirements of the standard.

The standard condition ----- maximum 8 frequencies
 Interference Signal Level : -43 dBm ---- maximum 4 frequencies
 Interference Signal Level : -63 dBm ---- no frequencies

PRELIMINARY / CONFIDENTIAL

DECT 2.4G BS Rev.4.1.2
 ALPS ELECTRIC CO., LTD.

5-3-5 Receiver Intermodulation Performance

< Temp Nominal, Volt Nominal >

BER in the D field shall be less than 0.001 at the following conditions.

Carrier signal Level : -80 dBm

Interference Signal Level : -47 dBm

A reference DECT interfere and a continuous wave interfere are introduced at 4 and 8 channel offset from desired channel to produce an intermodulation product.

5-3-6 Conducted Spurious Emissions when not allocated a transmit channel

< Temp Nominal, Volt Nominal >

a) Out of Band (with 100 kHz measurement bandwidth)

30 MHz ~ 88 MHz : -55.3 dBm MAX.

88MHz ~ 216 MHz : -51.7 dBm MAX

216 MH ~960 MHz : -49.3 dBm MAX

960 MHz ~ 12.417 GHz : -42 dBm MAX.

5-3-7 RSSI

a) RSSI voltage shall be between

< Temp Nominal, Volt Nominal >

RF input -33 dBm :

 $V_{-33}=T.B.D V$

RF input -93 dBm :

 $V_{-93}=T.B.D V$

The slope of RSSI vs RF input level shall be kept always positive slope between P-93 and P-33.

b) Ready Time:

< Temp Nominal, Volt Nominal >

RF input carrier signal "OFF → ON" to RSSI ready.

3μsec MAX. (TENTATIVE)

5-3-8 RX DATA DC output levelSignal Amplitude : 0.39V_{PP} ± 0.13V <Temp Nominal, Volt Nominal>

DC output Voltage : 1.5V ± 0.2V <Temp Nominal, Volt Nominal>

Input Level : -53 dBm

Modulation Deviation : 192 kHz

Modulation data pattern : "11110000" Sequence

Load impedance : 1 M ohm

5-3-9 Demod. Out Polarity

Fc + ΔF ----- "H"

Fc - ΔF ----- "L"

PRELIMINARY / CONFIDENTIAL

DECT 2.4G BS Rev.4.1.2

ALPS ELECTRIC CO., LTD.

5-4 CURRENT CONSUMPTION

< Temp Nominal , Volt Nominal >

5-4-1 in Transmit slot :T.B.D mA MAX.

5-4-2 in TX blind slot :T.B.D mA MAX

5-4-3 in Receive slot :T.B.D mA MAX.

5-4-4 in RX blind slot :T.B.D mA MAX

Attention : All interface signal shall be kept "LOW" during RFON and PLL PWR DWN "LOW". Otherwise interface leakage current must be taken in account for active "LOW" interface and PLL CLOCK, PLL DATA and PLL ENABLE.

5-5 COLD START UP TIME

Radio module shall be work 100μsec after the RFON and PLL PWR DWN turned on.

PRELIMINARY / CONFIDENTIAL

DECT 2.4G BS Rev.4.1.2
ALPS ELECTRIC CO., LTD.

6 RELIABILITY TEST

6-1 TEST METHOD

6-1-1 High Temperature Test : (No power applied)

The unit shall be subjected to unpowered storage at 70°C for a period of 96 hours. After removal from storage, the unit shall be powered during 1 hour minimum in the room temperature. The unit shall meet the specification of table-1.

6-1-2 High Temperature Test : (Power applied)

The unit shall be subjected to powered unpowered storage at 70°C for a period of 96 hours. After removal from storage, the unit shall be during 1 hour minimum in the room temperature. The unit shall meet the specifications of table-1.

6-1-3 Temperature Test :

The unit shall be subjected to unpowered storage at -10°C for a period of 96 hours. After removal from storage, the unit shall be powered during 1 hour minimum in the room temperature. The unit shall meet the specifications of table-1.

6-1-4 Temperature Shock :

The unpowered unit shall be subjected to 10 cycles of temperature cycle testing as follows. After removal from cycle testing, the unit shall be powered during 1 hour minimum in the room temperature. The unit shall then meet the specifications of table-1.

-20°C for 20 minutes]	
+80°C for 20 minutes]	1 cycle

6-1-5 Humidity Test :

The unit shall be subjected to unpowered storage at 40°C and 90% for a period of 96 hours. After removal from storage, the unit shall be powered during 1 hour minimum in the room temperature. The unit shall meet the specifications of table-1.

6-1-6 Vibration Test :

The unit shall unpowered and shall be subjected to a swept frequency vibration test as follows. After removal from vibration, the unit shall be powered during 1 hour minimum in the room temperature. The unit shall meet the specification of table-1.

Vibration Frequency	:	10 Hz, 55 Hz, 10 Hz
		(1 cycle / 1 minutes)
Total Amplitude	:	1 mm
Direction	:	X, Y, Z

(Each direction 40 minutes)

6-1-7 Drop Test :

The unit shall be subjected to unpowered drop test follows. After removal from test, the unit shall be powered during 1 hour minimum in the room temperature. And then the unit shall be measured and meet the specification of table-1.

Drop Point (Height)	:	1 m
Receiving board	:	Wooden board (20 x 20 x 3 cm.)
Drop times	:	1 times
Direction	:	Any direction without the part of connector

PRELIMINARY / CONFIDENTIAL

DECT 2.4G BS Rev.4.1.2

ALPS ELECTRIC CO., LTD.

6-1-8 Resistance to reflow soldering:

The unit shall meet the electric characteristics (section 5), after reflow soldering based on the sub-clause 10-4.

6-2 TABLE-1

TX Frequency Accuracy	±75 KHz MAX.
Normal Transmitter Power	+20 dBm to + 26 dBm
Input Sensitivity	-86dBm MAX.

7 LIFE SUPPORT APPLICATIONS

These products are not designed for use in life support appliances, devices or systems where malfunction of these products can reasonably be expected to result in personal injury. ALPS customers using or selling these products for use in such applications do so at their own risk and agree to fully indemnify ALPS for any damages resulting from such improper use or sale.

PRELIMINARY / CONFIDENTIAL

DECT 2.4G BS Rev.4.1.2
ALPS ELECTRIC CO., LTD.

8 PIN DESCRIPTION

Pin No.	Pin Name	I / O	Description
1	GND	---	Ground pin
2	TX/RX SWITCH	I	Transmit receive selector V_{IH} = Transmit V_{IL} = Receive
3	ANT SW 1 **	I	Antenna diversity control. V_{IH} =RF1 (ANT1) active V_{IL} =RF1 (ANT1) non active
4,5	Vcc PA	I	Supply voltage for Power amplifier circuits. +4.0V typ.
6,7	GND	---	Ground pin
8	RFON	I	Radio module main power switch V_{IH} = Power on V_{IL} = Power down
9,10	GND	---	Ground pin
11	N.C.	O	This terminal do not connect any signals (include GND and Vcc)
12	PLLPD	I	Power control of synthesizer. V_{IH} = Power down V_{IL} = Power ON
13,14	N.C.	O	This terminal do not connect any signals (include GND and Vcc)
15	GND	---	Ground pin
16	N.C.	O	This terminal do not connect any signals (include GND and Vcc)
17	PLL PWR DWN	I	Radio module VCO power switch. Normally this pin connect to RFON V_{IH} = Power ON V_{IL} = Power down
18	VCC OC	I	Supply voltage for other circuits. +4.0V typ.
19	TX DATA	I	Gaussian filtered transmit data input. Input data polarity shall be reversed. This terminal is built-in for LPF so as to reduce a logic noise. Maximum peak amplitude shall be set to 670mVp-p (Loaded) when bit pattern would be "...11110000...".
20	PLL CLOCK	I	Synthesizer clock input for serial registers.
21	PLL DATA	I	Synthesizer binary data input.
22	PLL ENABLE	I	Load enable input for synthesizer.
23~28	GND	---	Ground pin
29	RX DATA	O	Demodulated output signal Polarity : binary "1" = DC output - ΔV Binary "0" = DC output + ΔV
30	SLICE CTRL	I	Switch tracking and hold of data slicer circuit. V_{IL} = tracking V_{IH} = Hold
31	SLICE OUT	O	Data comparator reference voltage output. SLICE CTRL V_{IL} = S-field tracking(sampling) SLICE CTRL V_{IH} = hold reference voltage
32	RSSI	O	Voltage output of the received signal strength indicator (RSSI).
33	GND	---	Ground pin
34	SYS CLOCK	I	System clock input. 10.368MHz.
35~38	GND	---	Ground pin
39	PA RAMP	I	Controls ON / OFF of transmit power amplifier. V_{IH} =TX P.A. ON V_{IL} =TX P.A. OFF
40	ANT SW 2 **	I	Antenna diversity control. V_{IH} =RF2 (ANT2) active V_{IL} =RF2 (ANT2) non active
41	GND	---	Ground pin
42	RF2	I/O	RF In/Out Port 2
43~48	GND	---	Ground pin
49	RF1	I/O	RF In/Out Port 1

There is a possibility to change an arrangement of a terminal for a performance improvement and PCB design.

PRELIMINARY / CONFIDENTIAL

DECT 2.4G BS Rev.4.1.2
ALPS ELECTRIC CO., LTD.

9 ELECTRICAL CHARACTERISTICS

PIN NAME		MIN.	TYP.	MAX.	UNIT	CONDITION
PLL CLOCK PLL DATA PLL ENABLE SLICE CTRL PLL PWR DWN PLLPD RFON	V_{IH} V_{IL}	2.4 0		VCC OC 0.8	V	$I_{IH} = 0.5mA$ $I_{IL} = -0.5mA$
TX DATA *1	V_{MID} Amplitude	0.64	1.25 0.67	0.71	V V_{P-P}	Symmetrical Gaussian filtered square wave (11110000..). $I_{IH}=1mA$. $I_{IL}= -1mA$. Binary "1" ---- $F_c - \Delta F$ Binary "0" ----- $F_c + \Delta F$
TX/RX SWITCH	V_{IH} V_{IL}	2.0 0		VCC OC 0.5	V	$I_{IH} = 2mA$ $I_{IL} = -0.1mA$
PA RAMP	V_{IH} V_{IL}	2.0 0		VCC OC 0.3	V	$I_{IH} = 1mA$ $I_{IL} = -0.1mA$
SYS CLOCK	V_{CLK-IN} Frequency Accuracy	1.5	2.0 10.368 ± 3	3.0	V_{P-P} MHz ppm	SYS CLOCK terminal loaded voltage ($I_{LOAD} \approx 1 mA$). Low-pass filtered square wave.
RX DATA	Signal amplitude DC output level	0.2 1.3	0.39 1.5	0.52 1.7	V_{P-P} V	RF input level : -53 dBm Modulation sequence: "...11110000..." Load impedance : $1M\Omega$
SLICE OUT	Voltage drop		1		mV /ms	$C_{hold} = 2700pF$
RSSI		0		2.8	V	$R_L = 1 M\Omega$
VCC OC		3.8	4.0	4.2	V	
VCC PA		3.8	4.0	4.2	V	

Note 1: A modulation deviation and frequency offset is guaranteed when amplitude of TXDATA and DC offset would be settled. TXDATA input shall be kept to DC offset voltage at least in TX blind slot. Amplitude and DC offset is specify during TXDATA "...11110000..." and under terminal loaded.

Absolute Maximum Rating

	MIN.	TYP.	MAX.	UNIT
Vcc OC, Vcc PA	-0.3		+5.5	V
Other Input	-0.3		VCC OC +0.3	V

This module is a high performance RF circuit with an ESD rating <2KeV and is ESD sensitive. Handling and assembly of this module should only be done ESD work stations.

PRELIMINARY / CONFIDENTIALDECT 2.4G BS Rev.4.1.2
ALPS ELECTRIC CO., LTD.

10 APPENDIX

10-1 PLL FREQUENCY AND CONTROL DATA TABLE

attention: There is a possibility to change PLL data for a performance improvement.

10-1-1 The Programmable Reference Divider

	MSB					LSB
Bit#	2111	1111	1110	0000	0000	
	0987	6543	2109	8765	4321	
Data	0000	0000	0000	0101	0110	N=21

10-1-2 The Programmable Function Register

	MSB					LSB
Bit#	2111	1111	1110	0000	0000	
	0987	6543	2109	8765	4321	
Data	0110	1000	0000	1001	1011	TX setup
Data	0110	1100	1001	0001	1011	RX setup

10-1-3 The Programmable Divider (PLL frequency table)

BAND	CHAN NEL	fRF	fvco	DIV	MSB				LSB
	0	2400.439	1200.220	2431	0000	0100	1011	0111	1100
	1	2401.426	1200.713	2432	0000	0100	1100	0000	0000
	2	2402.414	1201.207	2433	0000	0100	1100	0000	0100
	3	2403.401	1201.701	2434	0000	0100	1100	0000	1000
	4	2404.389	1202.194	2435	0000	0100	1100	0000	1100
	5	2405.376	1202.688	2436	0000	0100	1100	0001	0000
	6	2406.364	1203.182	2437	0000	0100	1100	0001	0100
	7	2407.351	1203.676	2438	0000	0100	1100	0001	1000
	8	2408.338	1204.169	2439	0000	0100	1100	0001	1100
	9	2409.326	1204.663	2440	0000	0100	1100	0010	0000
	10	2410.313	1205.157	2441	0000	0100	1100	0010	0100
	11	2411.301	1205.650	2442	0000	0100	1100	0010	1000
	12	2412.288	1206.144	2443	0000	0100	1100	0010	1100
	13	2413.276	1206.638	2444	0000	0100	1100	0011	0000
	14	2414.263	1207.132	2445	0000	0100	1100	0011	0100
	15	2415.250	1207.625	2446	0000	0100	1100	0011	1000
	16	2416.238	1208.119	2447	0000	0100	1100	0011	1100
	17	2417.225	1208.613	2448	0000	0100	1100	0100	0000
	18	2418.213	1209.106	2449	0000	0100	1100	0100	0100
	19	2419.200	1209.600	2450	0000	0100	1100	0100	1000
	20	2420.188	1210.094	2451	0000	0100	1100	0100	1100
	21	2421.175	1210.588	2452	0000	0100	1100	0101	0000
	22	2422.162	1211.081	2453	0000	0100	1100	0101	0100
	23	2423.150	1211.575	2454	0000	0100	1100	0101	1000
	24	2424.137	1212.069	2455	0000	0100	1100	0101	1100

PRELIMINARY / CONFIDENTIAL

DECT 2.4G BS Rev.4.1.2
ALPS ELECTRIC CO., LTD.

25	2425.125	1212.562	2456	0000	0100	1100	0110	0000
26	2426.112	1213.056	2457	0000	0100	1100	0110	0100
27	2427.100	1213.550	2458	0000	0100	1100	0110	1000
28	2428.087	1214.044	2459	0000	0100	1100	0110	1100
29	2429.074	1214.537	2460	0000	0100	1100	0111	0000
30	2430.062	1215.031	2461	0000	0100	1100	0111	0100
31	2431.049	1215.525	2462	0000	0100	1100	0111	1000
32	2432.037	1216.018	2463	0000	0100	1100	0111	1100
33	2433.024	1216.512	2464	0000	0100	1101	0000	0000
34	2434.012	1217.006	2465	0000	0100	1101	0000	0100
35	2434.999	1217.500	2466	0000	0100	1101	0000	1000
36	2435.986	1217.993	2467	0000	0100	1101	0000	1100
37	2436.974	1218.487	2468	0000	0100	1101	0001	0000
38	2437.961	1218.981	2469	0000	0100	1101	0001	0100
39	2438.949	1219.474	2470	0000	0100	1101	0001	1000
40	2439.936	1219.968	2471	0000	0100	1101	0001	1100
41	2440.924	1220.462	2472	0000	0100	1101	0010	0000
42	2441.911	1220.956	2473	0000	0100	1101	0010	0100
43	2442.898	1221.449	2474	0000	0100	1101	0010	1000
44	2443.886	1221.943	2475	0000	0100	1101	0010	1100
45	2444.873	1222.437	2476	0000	0100	1101	0011	0000
46	2445.861	1222.930	2477	0000	0100	1101	0011	0100
47	2446.848	1223.424	2478	0000	0100	1101	0011	1000
48	2447.836	1223.918	2479	0000	0100	1101	0011	1100
49	2448.823	1224.412	2480	0000	0100	1101	0100	0000
50	2449.810	1224.905	2481	0000	0100	1101	0100	0100
51	2450.798	1225.399	2482	0000	0100	1101	0100	1000
52	2451.785	1225.893	2483	0000	0100	1101	0100	1100
53	2452.773	1226.386	2484	0000	0100	1101	0101	0000
54	2453.760	1226.880	2485	0000	0100	1101	0101	0100
55	2454.748	1227.374	2486	0000	0100	1101	0101	1000
56	2455.735	1227.868	2487	0000	0100	1101	0101	1100
57	2456.722	1228.361	2488	0000	0100	1101	0110	0000
58	2457.710	1228.855	2489	0000	0100	1101	0110	0100
59	2458.697	1229.349	2490	0000	0100	1101	0110	1000
60	2459.685	1229.842	2491	0000	0100	1101	0110	1100
61	2460.672	1230.336	2492	0000	0100	1101	0111	0000
62	2461.660	1230.830	2493	0000	0100	1101	0111	0100
63	2462.647	1231.324	2494	0000	0100	1101	0111	1000
64	2463.634	1231.817	2495	0000	0100	1101	0111	1100
65	2464.622	1232.311	2496	0000	0100	1110	0000	0000
66	2465.609	1232.805	2497	0000	0100	1110	0000	0100
67	2466.597	1233.298	2498	0000	0100	1110	0000	1000
68	2467.584	1233.792	2499	0000	0100	1110	0000	1100
69	2468.572	1234.286	2500	0000	0100	1110	0001	0000
70	2469.559	1234.780	2501	0000	0100	1110	0001	0100
71	2470.546	1235.273	2502	0000	0100	1110	0001	1000
72	2471.534	1235.767	2503	0000	0100	1110	0001	1100

PRELIMINARY / CONFIDENTIALDECT 2.4G BS Rev.4.1.2
ALPS ELECTRIC CO., LTD.

73	2472.521	1236.261	2504	0000	0100	1110	0010	0000
74	2473.509	1236.754	2505	0000	0100	1110	0010	0100
75	2474.496	1237.248	2506	0000	0100	1110	0010	1000
76	2475.484	1237.742	2507	0000	0100	1110	0010	1100
77	2476.471	1238.236	2508	0000	0100	1110	0011	0000
78	2477.458	1238.729	2509	0000	0100	1110	0011	0100
79	2478.446	1239.223	2510	0000	0100	1110	0011	1000
80	2479.433	1239.717	2511	0000	0100	1110	0011	1100
81	2480.421	1240.210	2512	0000	0100	1110	0100	0000
82	2481.408	1240.704	2513	0000	0100	1110	0100	0100
83	2482.396	1241.198	2514	0000	0100	1110	0100	1000
84	2483.383	1241.692	2515	0000	0100	1110	0100	1100

BAND	CHAN NEL	fRF	fvco	DIV	MSB				LSB
RX	0	2289.847	1144.924	2319	0000	0100	1000	0011	1100
	1	2290.834	1145.416	2320	0000	0100	1000	0100	0000
	2	2291.822	1145.911	2321	0000	0100	1000	0100	0100
	3	2292.809	1146.405	2322	0000	0100	1000	0100	1000
	4	2293.797	1146.898	2323	0000	0100	1000	0100	1100
	5	2294.784	1147.392	2324	0000	0100	1000	0101	0000
	6	2295.772	1147.885	2325	0000	0100	1000	0101	0100
	7	2296.759	1148.380	2326	0000	0100	1000	0101	1000
	8	2297.746	1148.873	2327	0000	0100	1000	0101	1100
	9	2298.734	1149.367	2328	0000	0100	1000	0110	0000
	10	2299.721	1149.861	2329	0000	0100	1000	0110	0100
	11	2300.709	1150.353	2330	0000	0100	1000	0110	1000
	12	2301.696	1150.848	2331	0000	0100	1000	0110	1100
	13	2302.684	1151.342	2332	0000	0100	1000	0111	0000
	14	2303.671	1151.836	2333	0000	0100	1000	0111	0100
	15	2304.658	1152.328	2334	0000	0100	1000	0111	1000
	16	2305.646	1152.823	2335	0000	0100	1000	0111	1100
	17	2306.633	1153.317	2336	0000	0100	1001	0000	0000
	18	2307.621	1153.810	2337	0000	0100	1001	0000	0100
	19	2308.608	1154.304	2338	0000	0100	1001	0000	1000
	20	2309.596	1154.797	2339	0000	0100	1001	0000	1100
	21	2310.583	1155.292	2340	0000	0100	1001	0001	0000
	22	2311.570	1155.785	2341	0000	0100	1001	0001	0100
	23	2312.558	1156.279	2342	0000	0100	1001	0001	1000
	24	2313.545	1156.773	2343	0000	0100	1001	0001	1100
	25	2314.533	1157.265	2344	0000	0100	1001	0010	0000
	26	2315.520	1157.760	2345	0000	0100	1001	0010	0100
	27	2316.508	1158.254	2346	0000	0100	1001	0010	1000
	28	2317.495	1158.748	2347	0000	0100	1001	0010	1100
	29	2318.482	1159.240	2348	0000	0100	1001	0011	0000
	30	2319.470	1159.735	2349	0000	0100	1001	0011	0100
	31	2320.457	1160.229	2350	0000	0100	1001	0011	1000
	32	2321.445	1160.722	2351	0000	0100	1001	0011	1100

PRELIMINARY / CONFIDENTIALDECT 2.4G BS Rev.4.1.2
ALPS ELECTRIC CO., LTD.

33	2322.432	1161.216	2352	0000	0100	1001	0100	0000
34	2323.420	1161.709	2353	0000	0100	1001	0100	0100
35	2324.407	1162.204	2354	0000	0100	1001	0100	1000
36	2325.394	1162.697	2355	0000	0100	1001	0100	1100
37	2326.382	1163.191	2356	0000	0100	1001	0101	0000
38	2327.369	1163.684	2357	0000	0100	1001	0101	0100
39	2328.357	1164.177	2358	0000	0100	1001	0101	1000
40	2329.344	1164.672	2359	0000	0100	1001	0101	1100
41	2330.332	1165.166	2360	0000	0100	1001	0110	0000
42	2331.319	1165.660	2361	0000	0100	1001	0110	0100
43	2332.306	1166.152	2362	0000	0100	1001	0110	1000
44	2333.294	1166.647	2363	0000	0100	1001	0110	1100
45	2334.281	1167.141	2364	0000	0100	1001	0111	0000
46	2335.269	1167.634	2365	0000	0100	1001	0111	0100
47	2336.256	1168.128	2366	0000	0100	1001	0111	1000
48	2337.244	1168.621	2367	0000	0100	1001	0111	1100
49	2338.231	1169.116	2368	0000	0100	1010	0000	0000
50	2339.218	1169.609	2369	0000	0100	1010	0000	0100
51	2340.206	1170.103	2370	0000	0100	1010	0000	1000
52	2341.193	1170.596	2371	0000	0100	1010	0000	1100
53	2342.181	1171.089	2372	0000	0100	1010	0001	0000
54	2343.168	1171.584	2373	0000	0100	1010	0001	0100
55	2344.156	1172.078	2374	0000	0100	1010	0001	1000
56	2345.143	1172.572	2375	0000	0100	1010	0001	1100
57	2346.130	1173.064	2376	0000	0100	1010	0010	0000
58	2347.118	1173.559	2377	0000	0100	1010	0010	0100
59	2348.105	1174.053	2378	0000	0100	1010	0010	1000
60	2349.093	1174.546	2379	0000	0100	1010	0010	1100
61	2350.080	1175.040	2380	0000	0100	1010	0011	0000
62	2351.068	1175.533	2381	0000	0100	1010	0011	0100
63	2352.055	1176.028	2382	0000	0100	1010	0011	1000
64	2353.042	1176.521	2383	0000	0100	1010	0011	1100
65	2354.030	1177.015	2384	0000	0100	1010	0100	0000
66	2355.017	1177.508	2385	0000	0100	1010	0100	0100
67	2356.005	1178.001	2386	0000	0100	1010	0100	1000
68	2356.992	1178.496	2387	0000	0100	1010	0100	1100
69	2357.980	1178.990	2388	0000	0100	1010	0101	0000
70	2358.967	1179.484	2389	0000	0100	1010	0101	0100
71	2359.954	1179.976	2390	0000	0100	1010	0101	1000
72	2360.942	1180.471	2391	0000	0100	1010	0101	1100
73	2361.929	1180.965	2392	0000	0100	1010	0110	0000
74	2362.917	1181.458	2393	0000	0100	1010	0110	0100
75	2363.904	1181.952	2394	0000	0100	1010	0110	1000
76	2364.892	1182.445	2395	0000	0100	1010	0110	1100
77	2365.879	1182.940	2396	0000	0100	1010	0111	0000
78	2366.866	1183.433	2397	0000	0100	1010	0111	0100
79	2367.854	1183.927	2398	0000	0100	1010	0111	1000
80	2368.841	1184.421	2399	0000	0100	1010	0111	1100

PRELIMINARY / CONFIDENTIALDECT 2.4G BS Rev.4.1.2
ALPS ELECTRIC CO., LTD.

81	2369.829	1184.914	2400	0000	0100	1011	0000	0000
82	2370.816	1185.408	2401	0000	0100	1011	0000	0100
83	2371.804	1185.902	2402	0000	0100	1011	0000	1000
84	2372.791	1186.396	2403	0000	0100	1011	0000	1100

10-1-4 Initialization Sequence

Radio module initialize is necessary as being after the Vcc OC turned on.

- 1) Send data of PLL programmable reference divider. A width of PLL ENABLE of this case can apply CASE1 timing.
- 2) Send data of PLL programmable divider. A width of PLL ENABLE of this case can apply CASE1 timing.
- 3) Send data of PLL modes control register. A width of PLL ENABLE of this case must apply CASE2 timings.

10-1-5 Change of Channel

- 1) Send data of PLL programmable reference divider. A width of PLL ENABLE of this case must apply CASE2 timings.

10-1-6 Timing Chart (Please firstly send MSB.)

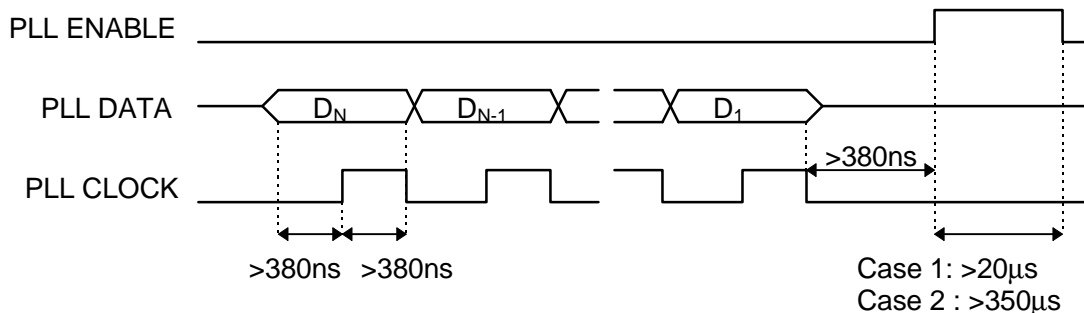

Fig-2. PLL timing chart

10-2 EXAMPLE OF INTERFACE TIMING

10-2-2 Transmit mode

PIN	Blind Slot	Active Transmit Slot
PLL DATA	[Pulse]	
PLL CLOCK	[Pulse]	
PLL ENABLE	[Pulse]	
RFON	[High]	[High]
PLL PWR DWN	[Low]	[Low]
RSYS CLOCK	[High]	[High]
PLLPD	[High]	[Low]
TX DATA		[Pulse]
TX/RX SWITCH	[Low]	[High]
PA RAMP		[Ramp]
ANTSW1		[High]
ANTSW2		[High]

Description of changing signals:

For the radio module, the reference of the radio timing is the transmission of bit 0 (first bit of S-field) at its TX DATA input. This reference will be called B0.

Time slot N-1: Blind slot for synthesizer

- B000: Transfer synthesizer data for time slot N with PLL CLOCK and ENABLE.
RFON and PLL PWR DWN changes from low to high.
TX DATA changes from low to modulation center value.
SYS CLOCK changes from low to active.
PLLPD changes from high to low.
- B456: PLLPD changes from low to high.
- B459: SYS CLOCK changes from active to low
- B473: TX/RX SWITCH changes from low to high.
ANT SW1 or ANT SW2 changes from low to high.
PA RAMP changes from low to high.

Time slot N: Active transmit slot

- B000: Transmit data on TX DATA input, during 420 bits.
- B424: PA RAMP changes from high to low.
- B438: TX/RX SWITCH changes from high to low.
- B442: ANT SW1 and ANT Sw2 changes from high to low
RFON and PLL PWR DWN changes from high to low.

PRELIMINARY / CONFIDENTIAL

DECT 2.4G BS Rev.4.1.2
ALPS ELECTRIC CO., LTD.

10-2-2 Receive mode

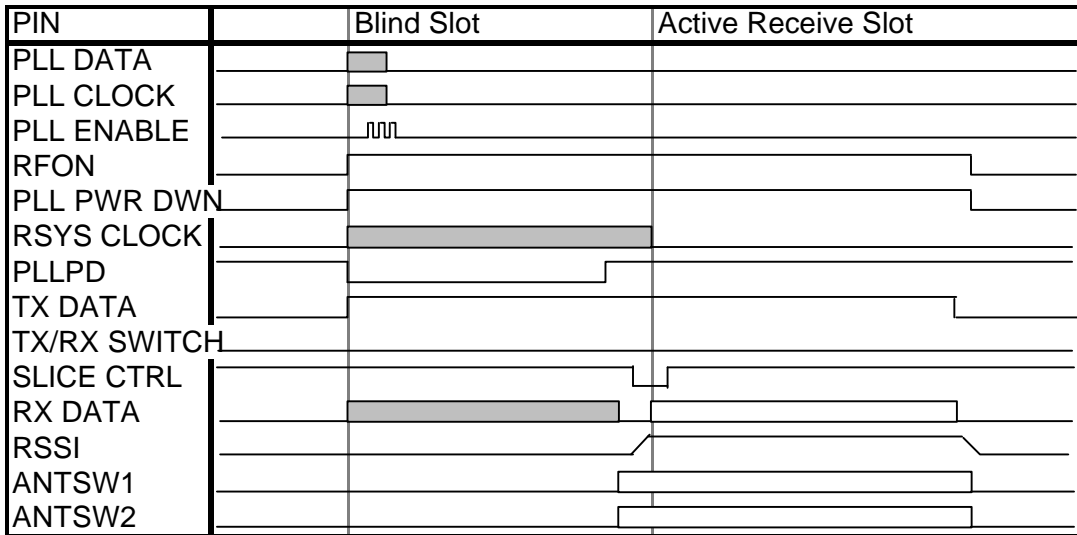

Time slot N-1: Blind slot for synthesizer

- B000: Transfer synthesizer data for time slot N with PLL CLOCK and ENABLE. RFON and PLL PWR DWN changes from low to high. TX DATA changes from low to modulation center value. SYS CLOCK changes from low to active. PLLPD changes from high to low
- B450: PLLPD changes from low to high.
- B465: ANT SW1 or ANT SW2 changes from low to high. SLICE CTRL changes from high to low.

Time slot N: Active receive slot

- B000: Receive data on RX DATA output, during 420 bits.
- B015: SLICE CTRL changes from low to high.
- B442: TX DATA changes from modulation center value to low. ANT SW1 and ANT Sw2 changes from high to low RFON and PLL PWR DWN changes from high to low

Note 1(SYS CLOCK)

Sys clock (REF_CLK) is recommended to be continuously "always on".

Note 2(ANT SW1, 2)

ANT SW1, 2 is tied to TX/RX SWITCH "on" timing in transmit slot. In receive slot, ANT SW1, 2 will be active 5 bits after PLLPD "on".

ANT SWITCH 1	ANT SWITCH 2	Active antenna
L	L	Low current mode
H	L	ANT 1 active
L	H	ANT 2 active
H	H	Do not select this state.

PRELIMINARY / CONFIDENTIAL

DECT 2.4G BS Rev.4.1.2
ALPS ELECTRIC CO., LTD.

10-3 Recommended soldering condition

10-3-1 Heating method

Double heating method with hot air.

10-3-2 Temperature measurement

Thermocouple 0.1~0.2 Φ CA(K) or CC(T) at soldering portion.

10-3-3 Solder condition.

Sn/63% Pb/35% with Ag/2%

10-3-4 Temperature profile

Temperature profile (Allowable soldering number of times "1 time")

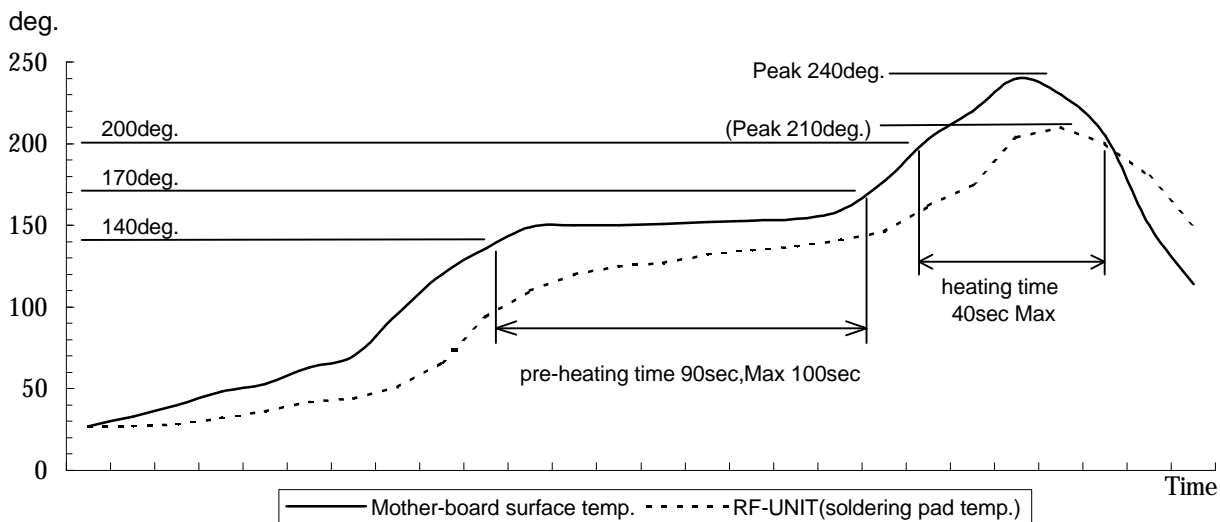

PRELIMINARY / CONFIDENTIAL

DECT 2.4G BS Rev.4.1.2
ALPS ELECTRIC CO., LTD.