

	A	B	C	D	E
1	REV LTR	DATE	REV . DIMENSION		DESIGN APPROVE
	△B				
	△C				

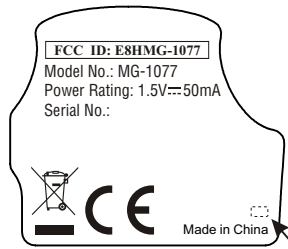

VENDER UL MARK

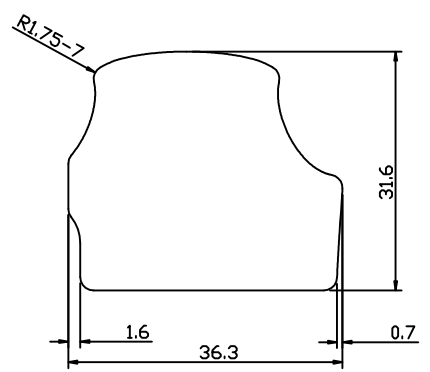

NOTES:

- 1.MATERIAL: SYNTHETIC PAPER t=0.1mm (WITH GLUE)
(UL/CSA APPROVED)
- 2.BACKGROUND COLOR: WHITE
- 3.CHARACTER COLOR: PANTONE Process Black C
- 4.FINISHED: ADHESIVE.
- 5.LABEL VENDOR HAS TO BE APPRD. BY UL/CSA.
- 6.THIS PRODUCT/COMPONENT MUST COMPLY WITH CHICONY SPECIFICATION "ISO 361"

MG-1077		253-01077L-		NO BRAND	
MODEL NO.		PART NO.		REMARK	
CHICPNY ELECTRONICS CP.,LTD			MAT.: NOTES		MODEL NO.: MG-1077
APPROVED	CHECKED	DESIGNED	SPEC: NOTES		
WILLIAM	T.S. MAGGIE	CLAIRE	FINISH: NOTES		NAME: (For Mouse) SPEC. ID LABEL
			TOL:	Q'TY	
12/01-'11	12/01-'11	12/01-'11	SCALE: 1 : 1	UNIT: MM	DWG NO.: MG1077-FCC-X1

A B C D E