

	A	B	C	D	E
1	REV LTR	DATE	REV . DIMENSION	DESIGN	APPROVE
	△B				
	△C				

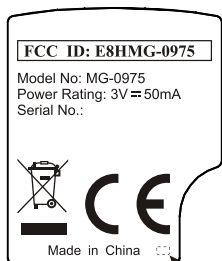

VENDER UL MARK.

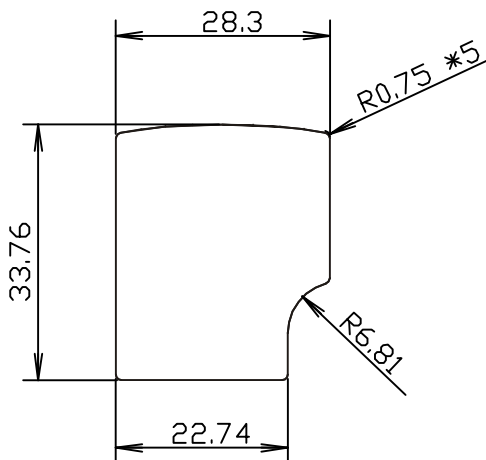

REFERENCE ONLY

NOTES:

- 1.MATERIAL: SYNTHETIC PAPER t=0.1mm (WITH GLUE)
- 2.BACKGROUND COLOR: WHITE
- 3.CHARACTER COLOR: PANTONE Process Black C
- 4.FINISHED: ADHESIVE.
- 5.LABEL VENDOR HAS TO BE APPRD. BY UL/CSA.
- 6.THIS PRODUCT/COMPONENT MUST COMPLY WITH CHICONY SPECIFICATION "ISO 361"

MG-0975		253-00975L-A01		NO BRAND	
MODEL NO.		PART NO.		REMARK	
CHICPNY ELECTRONICS CO.,LTD			MAT.: NOTES		MODEL NO.: MG-0975
APPROVED	CHECKED	DESIGNED	SPEC: NOTES		
		CLAIRE	FINISH: NOTES		NAME: (FOR MOUSE) SPEC. ID LABEL
			TOL:	Q'TY	
		07/19-'10	SCALE: 1 : 1		UNIT: MM
			DWG NO.:		09750140L-X1

A B C D E