

TOSHIBA
Leading Innovation >>>

User's Manual

WT10-A/WT8-B

Encore 2

Series

Table of Contents

<i>Chapter 1</i>	TOSHIBA Legal, Regulatory and Safety	
	Copyright, Disclaimer and Trademarks	1-1
	Regulatory Information	1-2
	Video Standard Notice	1-7
	OpenSSL Toolkit License Issues	1-8
	FreeType License Issues	1-10
	ENERGY STAR® Program	1-14
	Disposing of the computer and the computer's batteries	1-14
	General Precautions	1-14
	Safety Icons	1-17
<i>Chapter 2</i>	Getting Started	
	Equipment checklist	2-1
	Conventions	2-1
	Using your tablet for the first time	2-2
	Getting to know Windows	2-7
	Turning off the power	2-8
<i>Chapter 3</i>	The Grand Tour	
	The Grand Tour for WT10-A	3-1
	The Grand Tour for WT8-B	3-4
	Internal Hardware Components	3-7
<i>Chapter 4</i>	Operating Basics	
	Using the Touch Screen	4-1
	3D Playback on an External 3D Device	4-2
	Battery	4-3
	GPS Function	4-6
	Memory media	4-7
	USB device	4-10
	External Display	4-11
	Optional TOSHIBA Accessories	4-13
	Sound System and Video mode	4-14
<i>Chapter 5</i>	Utilities and Advanced Usage	
	Utilities and Applications	5-1
	Special features	5-2
	TruCapture	5-3

	TOSHIBA Setup Utility	5-3
	System Recovery	5-4
<i>Chapter 6</i>	Troubleshooting	
	Problem solving process	6-1
	Hardware and system checklist	6-4
	TOSHIBA support	6-9
<i>Chapter 7</i>	Appendix	
	Specifications	7-1
	AC Power Cord and Connectors	7-2
	Information for Wireless Devices	7-3
	Legal Footnotes	7-11
	Glossary	7-13
	Index	

Chapter 1

TOSHIBA Legal, Regulatory and Safety

This chapter states the Legal, regulatory and safety information applicable to TOSHIBA computers.

Copyright, Disclaimer and Trademarks

Copyright

© 2014 by TOSHIBA Corporation. All rights reserved. Under the copyright laws, this manual cannot be reproduced in any form without the prior written permission of TOSHIBA. No patent liability is assumed, with respect to the use of the information contained herein.

First edition May 2014

Copyright authority for music, movies, computer programs, databases and other intellectual property covered by copyright laws belongs to the author or to the copyright owner. Copyrighted material can be reproduced only for personal use or use within the home. Any other use beyond that stipulated above (including conversion to digital format, alteration, transfer of copied material and distribution on a network) without the permission of the copyright owner is a violation of copyright or author's rights and is subject to civil damages or criminal action. Please comply with copyright laws in making any reproduction from this manual.

Disclaimer

This manual has been validated and reviewed for accuracy. The instructions and descriptions it contains are accurate for your computer at the time of this manual's production. However, succeeding computers and manuals are subject to change without notice. TOSHIBA assumes no liability for damages incurred directly or indirectly from errors, omissions or discrepancies between the computer and the manual.

Trademarks

Intel, Intel SpeedStep, Intel Core and Centrino are trademarks or registered trademarks of Intel Corporation.

Windows, Microsoft and Windows logo are registered trademarks of Microsoft Corporation.

The Bluetooth® word mark and logos are registered trademarks owned by Bluetooth SIG, Inc. and any use of such marks by Toshiba Corporation and its affiliates is under license.

The terms HDMI and HDMI High-Definition Multimedia Interface, and the HDMI Logo are trademarks or registered trademarks of HDMI Licensing LLC in the United States and other countries.

Secure Digital and SD are trademarks of SD Card Association.

Dolby and the double-D symbol are trademarks of Dolby Laboratories.

All other product names and service names in this manual may be trademarks or registered trademarks of their respective companies.

Regulatory Information

FCC information

FCC notice "Declaration of Conformity Information"

This equipment has been tested and found to comply with the limits for a Class B digital device, pursuant to part 15 of the FCC rules. These limits are designed to provide reasonable protection against harmful interference in a residential installation. This equipment generates, uses and can radiate radio frequency energy and, if not installed and used in accordance with the instructions, may cause harmful interference to radio communications. However, there is no guarantee that interference will not occur in a particular installation. If this equipment does cause harmful interference to radio or television reception, which can be determined by turning the equipment off and on, the user is encouraged to try to correct the interference by one or more of the following measures:

- Reorient or relocate the receiving antenna.
- Increase the separation between the equipment and receiver.
- Connect the equipment into an outlet on a circuit different from that to which the receiver is connected.
- Consult the dealer or an experienced radio/TV technician for help.



Only peripherals complying with the FCC class B limits may be attached to this equipment. Operation with non-compliant peripherals or peripherals not recommended by TOSHIBA is likely to result in interference to radio and TV reception. Shielded cables must be used between the external devices and the computer's Micro HDMI port, Universal Serial Bus (USB 2.0 and 3.0) ports as well as Headphone/Microphone combo jacks. Changes or modifications made to this equipment, not expressly approved by TOSHIBA or parties authorized by TOSHIBA could void the user's authority to operate the equipment.

FCC conditions

This device complies with part 15 of the FCC Rules. Operation is subject to the following two conditions:

1. This device may not cause harmful interference.
2. This device must accept any interference received, including interference that may cause undesired operation.

Contact

Address: TOSHIBA America Information Systems, Inc.
9740 Irvine Boulevard
Irvine, California 92618-1697

Telephone: (949) 583-3000



This information is only applicable for the countries/regions where it is required.

EU Declaration of Conformity



This product is carrying the CE-Mark in accordance with the related European Directives. Responsible for CE-Marking is TOSHIBA EUROPE GMBH, Hammfelddamm 8, 41460 Neuss, Germany. The complete and official EU Declaration of Conformity can be found on TOSHIBA's web site <http://epps.toshiba-teg.com> on the Internet.

CE compliance

This product is labeled with the CE Mark in accordance with the applicable European Directives, notably RoHS Directive 2011/65/EU, Radio Equipment and Telecommunications Terminal Directive 1999/5/EC, Ecodesign Directive 2009/125/EC (ErP) and the related implementing measures.

This product and the original options are designed to observe the related EMC (Electromagnetic Compatibility) and safety standards. However, TOSHIBA cannot guarantee that this product still observes these EMC standards if options or cables not produced by TOSHIBA are connected or implemented. In this case the persons who have connected/implemented those options/cables have to provide assurance that the system (PC plus options/cables) still fulfils the required standards. To avoid general EMC problems, the following guidance should be noted:

-
- Only CE marked options should be connected/implemented
 - Only best shielded cables should be connected

Working environment

This product was designed to fulfil the EMC (Electromagnetic Compatibility) requirements to be observed for so-called "Residential, commercial and light industry environments". TOSHIBA do not approve the use of this product in working environments other than the above mentioned "Residential, commercial and light industry environments".

For example, the following environments are not approved:

- Industrial Environments (e.g. environments where a mains voltage of 380 V three-phase is used)
- Medical Environments
- Automotive Environments
- Aircraft Environments

Any consequences resulting from the use of this product in working environments that are not approved are not the responsibility of TOSHIBA.

The consequences of the use of this product in non-approved working environments may be:

- Interference with other devices or machines in the near surrounding area.
- Malfunction of, or data loss from, this product caused by disturbances generated by other devices or machines in the near surrounding area.

Therefore TOSHIBA strongly recommend that the electromagnetic compatibility of this product should be suitably tested in all non-approved working environments before use. In the case of automobiles or aircraft, the manufacturer or airline respectively should be asked for permission before use of this product.

Furthermore, for general safety reasons, the use of this product in environments with explosive atmospheres is not permitted.

VCCI Class B Information (Japan Only)

この装置は、クラスB情報技術装置です。この装置は、家庭環境で使用することを目的としていますが、この装置がラジオやテレビジョン受信機に近接して使用されると、受信障害を引き起こすことがあります。取扱説明書に従って正しい取り扱いをしてください。

VCCI-B

Canadian regulatory information (Canada only)

This digital apparatus does not exceed the Class B limits for radio noise emissions from digital apparatus as set out in the Radio Interference Regulation of the Canadian Department of Communications.

Note that Canadian Department of Communications (DOC) regulations provide, that changes or modifications not expressly approved by TOSHIBA Corporation could void your authority to operate this equipment.

This Class B digital apparatus meets all requirements of the Canadian Interference-Causing Equipment Regulations.

Cet appareil numérique de la class B respecte toutes les exigences du Règlement sur le matériel brouilleur du Canada.

Following information is only valid for EU-member States:

Disposal of products



The crossed out wheeled dust bin symbol indicates that products must be collected and disposed of separately from household waste. Integrated batteries and accumulators can be disposed of with the product. They will be separated at the recycling centres.

The black bar indicates that the product was placed on the market after August 13, 2005.

By participating in the separate collection of products and batteries, you will help to assure the proper disposal of products and batteries and thus help to prevent potential negative consequences for the environment and human health.

For more detailed information about the collection and recycling programmes available in your country, please visit our website

(www.toshiba.eu/recycling) or contact your local council office or the retail outlet where you purchased the product.

Disposal of batteries and/or accumulators



The crossed out wheeled dust bin symbol indicates that batteries and/or accumulators must be collected and disposed of separately from household waste.

If the battery or accumulator contains more than the specified values of lead (Pb), mercury (Hg), and/or cadmium (Cd) defined in the European Battery Directive, then the chemical symbols for lead (Pb), mercury (Hg) and/or cadmium (Cd) will appear below the crossed out wheeled dust bin symbol.

By participating in the separate collection of batteries, you will help to assure the proper disposal of products and batteries and thus help to prevent potential negative consequences for the environment and human health. To achieve this you should take any battery and/or accumulator to your local recycling site, or to a retail outlet or facility that offers to collect these devices for environmentally friendly disposal, ensuring that the terminal contacts are covered by non-conductive tape.

For more detailed information about the collection and recycling programmes available in your country, please visit our website

(www.toshiba.eu/recycling) or contact your local council office or the retail outlet where you purchased the product.



These symbols may not stick depending on the country and region where you purchased.

REACH - Compliance Statement

The European Union (EU) chemical regulation, REACH (Registration, Evaluation, Authorization and Restriction of Chemicals), entered into force on 1 June 2007, with phased deadlines to 2018.

Toshiba will meet all REACH requirements and is committed to provide our customers with information about the presence in our articles of substances included on the candidate list according to REACH regulation.

Please consult the following website

www.toshiba.eu/reach for information about the presence in our articles of substances included on the candidate list according to REACH in a concentration above 0.1% weight by weight.

Following information is only for Turkey:

- Disposal of products:



The crossed wheelie bin symbol means that this product should not be collected and disposed with other household wastes. When product become waste at the end- of-life, to protect environment and human health, it should be given to nearest collection recycling or disposal center. For more information about collection and recycling programs in your country please contact your local authority or the retailer where the product was purchased.

- Compliant with AEEE Directive.
- The number of possible pixel failures of your display is defined according to ISO 9241-307 standards. If the number of pixel failures is less than this standard, they will not be counted as defect or failure.
- Battery is a consumption product, since the battery time depends on the usage of your computer. If the battery can not be charged at all, then it is a defect or failure. The changes in battery time is not a defect or failure.

Following information is only for India:



The use of this symbol indicates that this product may not be treated as household waste.

By ensuring this product is disposed of correctly, you will help prevent potential negative consequences for the environment and human health, which could otherwise be caused by inappropriate waste handling of this product.

For more detailed information about recycling of this product, please visit our website

(<http://www.toshiba-india.com>) or contact call center (1800-200-8674).



These symbols may not stick depending on the country and region where you purchased.

Video Standard Notice

THIS PRODUCT IS LICENSED UNDER THE AVC, THE VC-1 AND MPEG-4 VISUAL PATENT PORTFOLIO LICENSE FOR THE PERSONAL AND NON-COMMERCIAL USE OF A CONSUMER FOR (I) ENCODING VIDEO IN COMPLIANCE WITH THE ABOVE STANDARDS ("VIDEO") AND/OR (II) DECODING AVC, VC-1 AND MPEG-4 VIDEO THAT WAS ENCODED BY A CONSUMER ENGAGED IN A PERSONAL AND NONCOMMERCIAL ACTIVITY AND/OR WAS OBTAINED FROM A VIDEO PROVIDER LICENSED BY MPEG LA TO PROVIDE SUCH VIDEO. NO LICENSE IS GRANTED OR SHALL BE IMPLIED FOR ANY

OTHER USE. ADDITIONAL INFORMATION INCLUDING THAT RELATING TO PROMOTIONAL, INTERNAL AND COMMERCIAL USES AND LICENSING MAY BE OBTAINED FROM MPEG LA, L.L.C. SEE [HTTP://WWW.MPEGLA.COM](http://www.mpegla.com).

OpenSSL Toolkit License Issues

LICENSE ISSUES

=====

The OpenSSL toolkit stays under a dual license, i.e. both the conditions of the OpenSSL License and the original SSLeay license apply to the toolkit. See below for the actual license texts. Actually both licenses are BSD-style Open Source licenses. In case of any license issues related to OpenSSL please contact openssl-core@openssl.org.

OpenSSL License

/*=====

Copyright (c) 1998-2011 The OpenSSL Project. All rights reserved.

Redistribution and use in source and binary forms, with or without modification, are permitted provided that the following conditions are met:

1. Redistributions of source code must retain the above copyright notice, this list of conditions and the following disclaimer.
2. Redistributions in binary form must reproduce the above copyright notice, this list of conditions and the following disclaimer in the documentation and/or other materials provided with the distribution.
3. All advertising materials mentioning features or use of this software must display the following acknowledgment:

"This product includes software developed by the OpenSSL Project for use in the OpenSSL Toolkit. "

(<http://www.openssl.org/>)

4. The names "OpenSSL Toolkit" and "OpenSSL Project" must not be used to endorse or promote products derived from this software without prior written permission. For written permission, please contact openssl-core@openssl.org.
5. Products derived from this software may not be called "OpenSSL" nor may "OpenSSL" appear in their names without prior written permission of the OpenSSL Project.
6. Redistributions of any form whatsoever must retain the following acknowledgment:

"This product includes software developed by the OpenSSL Project for use in the OpenSSL Toolkit"

(<http://www.openssl.org/>)

THIS SOFTWARE IS PROVIDED BY THE OpenSSL PROJECT ``AS IS'' AND ANY EXPRESSED OR IMPLIED WARRANTIES, INCLUDING, BUT

NOT LIMITED TO, THE IMPLIED WARRANTIES OF MERCHANTABILITY AND FITNESS FOR A PARTICULAR PURPOSE ARE DISCLAIMED. IN NO EVENT SHALL THE OpenSSL PROJECT OR ITS CONTRIBUTORS BE LIABLE FOR ANY DIRECT, INDIRECT, INCIDENTAL, SPECIAL, EXEMPLARY, OR CONSEQUENTIAL DAMAGES (INCLUDING, BUT NOT LIMITED TO, PROCUREMENT OF SUBSTITUTE GOODS OR SERVICES; LOSS OF USE, DATA, OR PROFITS; OR BUSINESS INTERRUPTION) HOWEVER CAUSED AND ON ANY THEORY OF LIABILITY, WHETHER IN CONTRACT, STRICT LIABILITY, OR TORT (INCLUDING NEGLIGENCE OR OTHERWISE) ARISING IN ANY WAY OUT OF THE USE OF THIS SOFTWARE, EVEN IF ADVISED OF THE POSSIBILITY OF SUCH DAMAGE.

=====

This product includes cryptographic software written by Eric Young (eay@cryptsoft.com). This product includes software written by Tim Hudson (tjh@cryptsoft.com).

*/

Original SSLeay License

/* Copyright (C) 1995-1998 Eric Young (eay@cryptsoft.com)

All rights reserved.

This package is an SSL implementation written by Eric Young (eay@cryptsoft.com).

The implementation was written so as to conform with Netscapes SSL.

This library is free for commercial and non-commercial use as long as the following conditions are aheared to. The following conditions apply to all code found in this distribution, be it the RC4, RSA, lhash, DES, etc., code; not just the SSL code. The SSL documentation included with this distribution is covered by the same copyright terms except that the holder is Tim Hudson (tjh@cryptsoft.com).

Copyright remains Eric Young's, and as such any Copyright notices in the code are not to be removed.

If this package is used in a product, Eric Young should be given attribution as the author of the parts of the library used.

This can be in the form of a textual message at program startup or in documentation (online or textual) provided with the package.

Redistribution and use in source and binary forms, with or without modification, are permitted provided that the following conditions are met:

1. Redistributions of source code must retain the copyright notice, this list of conditions and the following disclaimer.
2. Redistributions in binary form must reproduce the above copyright notice, this list of conditions and the following disclaimer in the documentation and/or other materials provided with the distribution.

-
3. All advertising materials mentioning features or use of this software must display the following acknowledgement:
"This product includes cryptographic software written by Eric Young (eay@cryptsoft.com)"
The word 'cryptographic' can be left out if the routines from the library being used are not cryptographic related :-).
4. If you include any Windows specific code (or a derivative thereof) from the apps directory (application code) you must include an acknowledgement:
"This product includes software written by Tim Hudson (tjh@cryptsoft.com)"

THIS SOFTWARE IS PROVIDED BY ERIC YOUNG ``AS IS'' AND ANY EXPRESS OR IMPLIED WARRANTIES, INCLUDING, BUT NOT LIMITED TO, THE IMPLIED WARRANTIES OF MERCHANTABILITY AND FITNESS FOR A PARTICULAR PURPOSE ARE DISCLAIMED. IN NO EVENT SHALL THE AUTHOR OR CONTRIBUTORS BE LIABLE FOR ANY DIRECT, INDIRECT, INCIDENTAL, SPECIAL, EXEMPLARY, OR CONSEQUENTIAL DAMAGES (INCLUDING, BUT NOT LIMITED TO, PROCUREMENT OF SUBSTITUTE GOODS OR SERVICES; LOSS OF USE, DATA, OR PROFITS; OR BUSINESS INTERRUPTION) HOWEVER CAUSED AND ON ANY THEORY OF LIABILITY, WHETHER IN CONTRACT, STRICT LIABILITY, OR TORT (INCLUDING NEGLIGENCE OR OTHERWISE) ARISING IN ANY WAY OUT OF THE USE OF THIS SOFTWARE, EVEN IF ADVISED OF THE POSSIBILITY OF SUCH DAMAGE.

The licence and distribution terms for any publically available version or derivative of this code cannot be changed. i.e. this code cannot simply be copied and put under another distribution licence [including the GNU Public Licence.]

*/

FreeType License Issues

The FreeType Project LICENSE

2006-Jan-27

Copyright 1996-2002, 2006 by

David Turner, Robert Wilhelm, and Werner Lemberg

Introduction

=====

The FreeType Project is distributed in several archive packages; some of them may contain, in addition to the FreeType font engine, various tools and contributions which rely on, or relate to, the FreeType Project.

This license applies to all files found in such packages, and which do not fall under their own explicit license. The license affects thus the FreeType font engine, the test programs, documentation and makefiles, at the very least.

This license was inspired by the BSD, Artistic, and IJG (Independent JPEG Group) licenses, which all encourage inclusion and use of free software in commercial and freeware products alike. As a consequence, its main points are that:

- We don't promise that this software works. However, we will be interested in any kind of bug reports. ('as is' distribution)
- You can use this software for whatever you want, in parts or full form, without having to pay us. ('royalty-free' usage)
- You may not pretend that you wrote this software. If you use it, or only parts of it, in a program, you must acknowledge somewhere in your documentation that you have used the FreeType code. ('credits')

We specifically permit and encourage the inclusion of this software, with or without modifications, in commercial products.

We disclaim all warranties covering The FreeType Project and assume no liability related to The FreeType Project.

Finally, many people asked us for a preferred form for a credit/disclaimer to use in compliance with this license. We thus encourage you to use the following text:

""

Portions of this software are copyright (C) <year> The FreeType Project
(www.freetype.org). All rights reserved.

""

Please replace <year> with the value from the FreeType version you actually use.

Legal Terms

=====

0. Definitions

Throughout this license, the terms 'package', 'FreeType Project', and 'FreeType archive' refer to the set of files originally distributed by the authors (David Turner, Robert Wilhelm, and Werner Lemberg) as the 'FreeType Project', be they named as alpha, beta or final release.

'You' refers to the licensee, or person using the project, where 'using' is a generic term including compiling the project's source code as well as linking it to form a 'program' or 'executable'. This program is referred to as 'a program using the FreeType engine'.

This license applies to all files distributed in the original FreeType Project, including all source code, binaries and documentation, unless otherwise stated in the file in its original, unmodified form as distributed in the original

archive. If you are unsure whether or not a particular file is covered by this license, you must contact us to verify this.

The FreeType Project is copyright (C) 1996-2000 by David Turner, Robert Wilhelm, and Werner Lemberg. All rights reserved except as specified below.

1. No Warranty

THE FREETYPE PROJECT IS PROVIDED `AS IS' WITHOUT WARRANTY OF ANY KIND, EITHER EXPRESS OR IMPLIED, INCLUDING, BUT NOT LIMITED TO, WARRANTIES OF MERCHANTABILITY AND FITNESS FOR A PARTICULAR PURPOSE. IN NO EVENT WILL ANY OF THE AUTHORS OR COPYRIGHT HOLDERS BE LIABLE FOR ANY DAMAGES CAUSED BY THE USE OR THE INABILITY TO USE, OF THE FREETYPE PROJECT.

2. Redistribution

This license grants a worldwide, royalty-free, perpetual and irrevocable right and license to use, execute, perform, compile, display, copy, create derivative works of, distribute and sublicense the FreeType Project (in both source and object code forms) and derivative works thereof for any purpose; and to authorize others to exercise some or all of the rights granted herein, subject to the following conditions:

- Redistribution of source code must retain this license file ('FTL.TXT') unaltered; any additions, deletions or changes to the original files must be clearly indicated in accompanying documentation. The copyright notices of the unaltered, original files must be preserved in all copies of source files.
- Redistribution in binary form must provide a disclaimer that states that the software is based in part of the work of the FreeType Team, in the distribution documentation. We also encourage you to put an URL to the FreeType web page in your documentation, though this isn't mandatory.

These conditions apply to any software derived from or based on the FreeType Project, not just the unmodified files. If you use our work, you must acknowledge us. However, no fee need be paid to us.

3. Advertising

Neither the FreeType authors and contributors nor you shall use the name of the other for commercial, advertising, or promotional purposes without specific prior written permission.

We suggest, but do not require, that you use one or more of the following phrases to refer to this software in your documentation or advertising materials: `FreeType Project', `FreeType Engine', `FreeType library', or `FreeType Distribution'.

As you have not signed this license, you are not required to accept it. However, as the FreeType Project is copyrighted material, only this license, or another one contracted with the authors, grants you the right to use, distribute, and modify it. Therefore, by using, distributing, or modifying the FreeType Project, you indicate that you understand and accept all the terms of this license.

4. Contacts

There are two mailing lists related to FreeType:

- freetype@nongnu.org
Discusses general use and applications of FreeType, as well as future and wanted additions to the library and distribution. If you are looking for support, start in this list if you haven't found anything to help you in the documentation.
- freetype-devel@nongnu.org
Discusses bugs, as well as engine internals, design issues, specific licenses, porting, etc.

Our home page can be found at

<http://www.freetype.org>

ENERGY STAR® Program



Your Computer model may be ENERGY STAR® compliant. If the model you purchased is compliant, it is labeled with the ENERGY STAR logo on the computer and the following information applies.

TOSHIBA is a partner in the ENERGY STAR Program and has designed this computer to meet the latest ENERGY STAR guidelines for energy efficiency. Your computer ships with the power management options preset to a configuration that will provide the most stable operating environment and optimum system performance for both AC power and battery modes.

To conserve energy, your computer is set to enter the low-power Sleep Mode which shuts down the system and display within 15 minutes of inactivity in AC power mode.

TOSHIBA recommends that you leave this and other energy saving features active, so that your computer will operate at its maximum energy efficiency. You can wake the computer from Sleep Mode by pressing the power button.

Your ENERGY STAR certified computer should be set by default to enter a low-power "sleep mode" after a period of inactivity. Simply touching the mouse or keyboard "wakes" the computer in seconds. These sleep features can save you up to \$23 per year (200 kWh per year in electricity) and prevent up to 300 pounds of greenhouse gas emissions annually. To learn how to adjust or activate these sleep settings on your computer, please go to:

www.energystar.gov/sleepinstructions

To activate sleep settings organization-wide quickly and easily through network tools, please go to

www.energystar.gov/powermanagement

Disposing of the computer and the computer's batteries

The computer's battery is not user-accessible. Contact an authorized TOSHIBA service provider for details regarding how to dispose of the computer and the batteries.

General Precautions

TOSHIBA computers are designed to optimize safety, minimize strain and withstand the rigors of portability. However, certain precautions should be

observed to further reduce the risk of personal injury or damage to the computer.

Be certain to read the general precautions below and to note the cautions included in the text of the manual.

Provide adequate ventilation

Always make sure your computer and AC adaptor have adequate ventilation and are protected from overheating when the power is turned on or when an AC adaptor is connected to a power outlet (even if your computer is in Sleep Mode). In this condition, observe the following:

- Never cover your computer or AC adaptor with any object.
- Never place your computer or AC adaptor near a heat source, such as an electric blanket or heater.
- Always provide sufficient space around the computer.

Overheating your computer or AC adaptor could cause system failure, computer or AC adaptor damage or a fire, possibly resulting in serious injury.

Creating a computer-friendly environment

To keep your computer in prime operating condition, protect your work area from:

- Dust, moisture, and direct sunlight.
- Equipment that generates a strong electromagnetic field, such as stereo speakers (other than speakers that are connected to the computer) or speakerphones.
- Rapid changes in temperature or humidity and sources of temperature change such as air conditioner vents or heaters.
- Extreme heat, cold, or humidity.
- Liquids and corrosive chemicals.

Stress injury

Carefully read the *Instruction Manual for Safety and Comfort*. It contains information on the prevention of stress injuries to your hands and wrists that can be caused by extensive use. It also includes information on work space design, posture and lighting that can help reduce physical stress.

Heat injury

- Avoid prolonged physical contact with the computer. If the computer is used for long periods, its surface can become very warm. While the temperature will not feel hot to the touch, if you maintain physical contact with the computer for a long time, for example if you rest the computer on your lap or if you keep your hands on the palm rest, your skin might suffer a low-heat injury.

-
- If the computer has been used for a long time, avoid direct contact with the metal plate supporting the various interface ports as this can become hot.
 - The surface of the AC adaptor can become hot when in use but this condition does not indicate a malfunction. If you need to transport the AC adaptor, you should disconnect it and let it cool before moving it.
 - Do not lay the AC adaptor on a material that is sensitive to heat as the material could become damaged.

Pressure or impact damage

Do not apply heavy pressure to the computer or subject it to any form of strong impact as this can damage the computer's components or otherwise cause it to malfunction.

Cleaning the computer

To help ensure long, trouble-free operation, keep the computer free of dust and dirt, and use care with all liquids around it.

- Be careful not to spill liquids into the computer. If the computer does get wet, turn the power off immediately and let the computer dry completely - in these circumstance you should get the computer inspected by an authorized service provider in order to assess the scope of any damage.
- Clean the plastics of the computer using a slightly water dampened cloth.
- You can clean the display screen by spraying a small amount of glass cleaner onto a soft, clean cloth and then wiping the screen gently with the cloth.



Never spray cleaner directly onto the computer or let liquid run into any part of it. Never use harsh or caustic chemical products to clean the computer.

Moving the computer

While the computer is designed for flexible day-to-day usage you should exercise a few simple precautions when moving it in order to help ensure trouble-free operation.

- Make sure all disk activity has ended before moving the computer.
- Turn off (shut down) the computer.
- Disconnect the AC adaptor and all peripherals before moving the computer.
- Before carrying your computer, shut it down, disconnect the AC adaptor and allow it to cool down - a failure to follow this instruction may result in minor heat injury.

-
- Be careful not to subject the computer to impact or shock - a failure to follow this instruction could result in damage to computer, computer failure or loss of data.
 - Never transport your computer with any cards installed - this may cause damage to either the computer and/or the card resulting in computer failure.
 - Always use a suitable carry case when transporting the computer.
 - When carrying your computer, be sure to hold it securely so that it does not fall or hit anything.
 - Do not carry your computer by holding any of its protruding elements.

Mobile phones

Please be aware that the use of mobile phones can interfere with the audio system. The operation of the computer will not be impaired in any way, but it is recommended that a minimum distance of 30cm is maintained between the computer and a mobile phone that is in use.

Instruction Manual for Safety and Comfort

All important information on the safe and proper use of this computer is described in the enclosed Instruction Manual for Safety and Comfort. Be sure to read it before using the computer.

Safety Icons

Safety icons are used in this manual to bring important information to your attention. Each type of message is identified as shown below.



Indicates a potentially hazardous situation, which could result in death or serious injury, if you do not follow instructions.



A caution informs you that improper use of equipment or failure to follow instructions may cause data loss, equipment damage, or may result in minor or moderate injury.



Please read. A note is a hint or advice that helps you make best use of your equipment.

Chapter 2

Getting Started

This chapter provides an equipment checklist, and basic information to start using your tablet.



- *Some of the features described in this manual may not function properly if you use an operating system that was not pre-installed by TOSHIBA.*
- *In this manual, both words "tablet" and "computer" refer to the TOSHIBA tablet.*

Equipment checklist

Carefully unpack your tablet, taking care to save the box and packaging materials for future use.

Hardware

Check to make sure you have all the following items:

- TOSHIBA Tablet
- AC adaptor (2-pin plug or 3-pin plug)
- Micro-USB cable
- USB Data and Charge Y-Cable (provided with some models)

Documentation

- User Information Guide
- Instruction Manual for Safety and Comfort

If any of the items are missing or damaged, contact your dealer immediately.



Conventions

This manual uses the following formats to describe, identify, and highlight terms and operating procedures.

Charm	By swiping in from the right edge of your screen, you will find a list of charms: Search , Share , Start , Devices and Settings .
Desktop	Tap the Desktop tile from the Start screen to access the desktop.

Start screen

You can go back to the Start screen from an app or the desktop by the following ways:



- Press the Windows® button () on your tablet.
- Tap the **Start** charm.
- Tap the **Start** button () in the lower-left corner of the screen (Only on **Desktop**).

For detailed information, please refer to the Windows Help and Support.

Apps view

You can find all of your apps including desktop programs in the Apps view.

To get to the Apps view:

- Slide up from the middle of the Start screen.
- Slide leftwards until the  icon appears on the lower-left corner of the Start screen, and then tap .

Using your tablet for the first time



Be sure to read the enclosed Instruction Manual for Safety and Comfort for information on the safe and proper use of this tablet. It is intended to help you be more comfortable and productive while using a tablet. By following the recommendations in it you may reduce your chance of developing a painful or disabling injury to your hand, arms, shoulders or neck.

This section provides basic information to start using your tablet. It covers the following topics:

- Connecting the AC adaptor
- Turning on the power
- Initial setup



- *Use a virus-check program and make sure it is updated regularly.*
- *Never format storage media without checking its content - formatting destroys all stored data.*
- *It is a good idea to periodically back up the internal storage of the tablet to external media. General storage media is not durable or stable over long periods of time and under certain conditions may result in data loss.*
- *Before you install a device or application, save any data in memory to the internal storage or other storage media. Failure to do so may result in the loss of data.*

Connecting the AC adaptor

Attach the AC adaptor when you need to charge the battery or you want to operate from AC power. It is also the fastest way to get started, because the battery pack will need to be charged before you can operate from battery power.

The AC adaptor can automatically adjust to any voltage ranging from 100 to 240 volts and to a frequency of either 50 or 60 hertz, enabling you to use this tablet in almost any country/region. The adaptor converts AC power to DC power and reduces the voltage supplied to this tablet.



- *Always use the TOSHIBA AC adaptor that was included with your tablet, or use AC adaptors specified by TOSHIBA to avoid any risk of fire or other damage to the tablet. Use of an incompatible AC adaptor could cause fire or damage to the tablet possibly resulting in serious injury. TOSHIBA assumes no liability for any damage caused by use of an incompatible adaptor.*
- *Never plug the AC adaptor into a power source that does not correspond to both the voltage and the frequency specified on the regulatory label of the unit. Failure to do so could result in a fire or electric shock, possibly resulting in serious injury.*
- *Always use or purchase power cables that comply with the legal voltage and frequency specifications and requirements in the country of use. Failure to do so could result in a fire or electric shock, possibly resulting in serious injury.*
- *The supplied power cord conforms to safety rules and regulations in the region the tablet is bought and should not be used outside this region. For use in other regions, please buy power cords that conform to safety rules and regulations in the particular region.*
- *Do not use a 3-pin to 2-pin conversion plug.*
- *When you connect the AC adaptor to the tablet, always follow the steps in the exact order as described in this User's Manual. Connecting the power cable to a live electrical outlet should be the last step otherwise the adaptor DC output plug could hold an electrical charge and cause an electrical shock or minor bodily injury when touched. As a general safety precaution, avoid touching any metal parts.*
- *Never place your tablet or AC adaptor on a wooden surface, furniture, or any other surface that could be marred by exposure to heat since the tablet base and AC adaptor's surface increase in temperature during normal use.*
- *Always place your tablet or AC adaptor on a flat and hard surface that is resistant to heat damage.*

Refer to the enclosed Instruction Manual for Safety and Comfort for detailed precautions and handling instructions.

Plug the USB connector of the Micro-USB cable into the AC adaptor

Figure 2-1 Plugging the Micro-USB cable into the AC adaptor

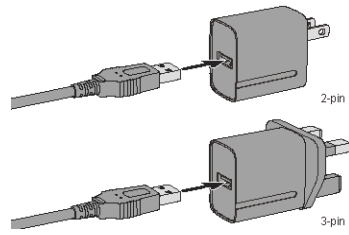

Either a 2n or 3n adaptor/cord will be included with the tablet depending on the 10del.

2. Plug the other smaller connector of the Micro-USB cable into the Micro-USB port on your tablet

You can also establish connection through the provided "USB Data and Charge Y-Cable". Please refer to the [USB device](#) section for more details

Figure 2-2 Plugging the Micro-USB cable into tablet (WT10-A)

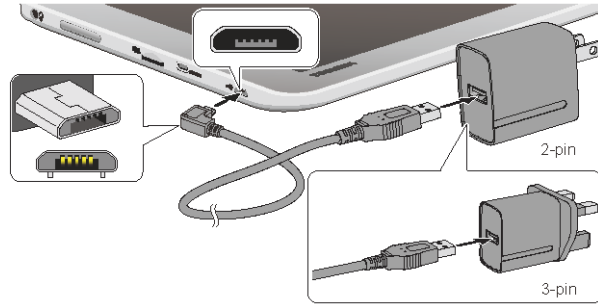
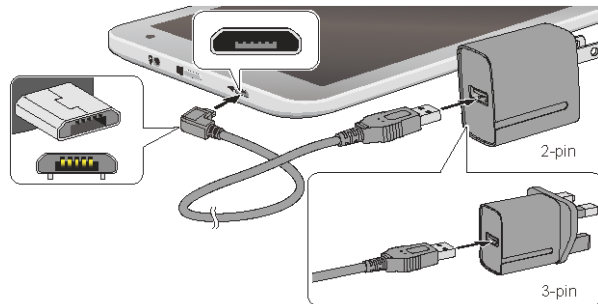

Figure 2-3 Plugging the Micro-USB cable into tablet (WT8-B)



Product appearance depends on the model you purchased

The Micro-USB connector of the Micro-USB cable must be correctly plugged into the Micro-USB port on the tablet. Failure to do so correctly may result in possible damage to the Micro-USB port

3. Plug the AC adaptor into a live wall outlet

Tuning on the power

This section describes how to turn on the power

- After you turn on the power for the first time, do not turn it off until you have set up the operating system
- Volume cannot be adjusted during Windows Setup

- The tablet can not be powered on by pressing the power button if the battery power is completely exhausted. It is recommended to charge the battery pack by connecting the AC adapter for 30 minutes before turning on the power

Press and hold the power button for 2-10 seconds to turn on the tablet

Figure 2-4 Turning on the power (WT10-A)

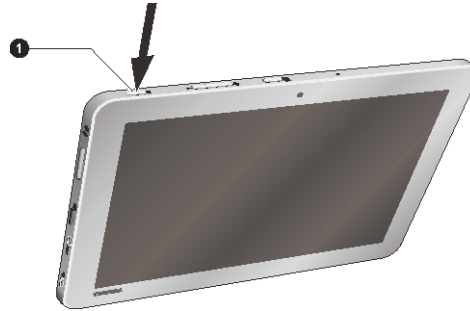
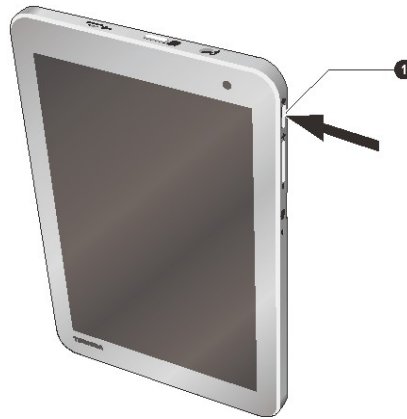

Figure 2-5 Turning on the power (WT8-B)



1. Power button

Product appearance depends on the model you purchased

Initial setup

The Windows Startup Screen will be the first screen displayed when you turn on the power. Follow the on-screen instructions on each screen in order to properly install the operating system

When it is displayed be sure to read the License Terms carefully.

Getting to know Windows

For detailed information on what is new and how to operate Windows, please refer to the Windows Help and Support.

Start screen

The Start screen is the launching pad for everything you can do in the Windows operating system, providing new and easy ways to access everything from your favorite apps and Web sites to your contacts and other important information.

From the Start screen, you can just start typing to search for what you want. From there, you can easily switch between results for apps, files, and more.

Charms

Use the Windows charms to start apps, find documents, set up system components, and perform most other computing tasks.

By swiping in from the right edge of your screen, you will find a list of charms: **Search**, **Share**, **Start**, **Devices** and **Settings**.



Search

This charm allows you to search your tablet (apps, settings and files), the web, or within an app. You can also find the **Search** icon on the upper right of the Start screen.



Share

This charm allows you to share items (links, photos, and more).



Start

This charm takes you to the Start screen or, if already on the Start screen, returns you to your last app.



Devices

This charm allows you to manage your hardware.



Settings

This charm allows you to access your tablet's settings (volume, brightness, connecting to the internet, and more).

Tiles

Tiles can be accessed and launched from the Start screen.



Typical Start screen tiles are the Desktop tile and Mail tile, as well as tiles representing all other applications downloaded to your system.

Windows Store

Although many applications will be pre-installed or built-in to your tablet, you will also have the ability to download many other applications.

In the Windows Store you can search for and browse thousands of apps, all grouped into easy to find categories.

Sign-in options

Windows offers a number of sign-in options including **Password** () , **PIN** () and **Picture password** () authentication to prevent from unauthorized access. You are allowed to select an option on the Windows login screen by clicking **sign-in options** if you have multiple sign-in methods set for a user account. Password authentication is the default sign-in option.

Turning off the power

The power can be turned off in one of the following modes, either Shut Down Mode, Sleep Mode or Hibernation Mode.

Shut Down Mode

When you turn off the power in Shut Down Mode, no data will be saved and the tablet will boot to the operating system's main screen the next time it is turned on.

1. If you have entered data, either save it to the internal storage or to other storage media.



- *Never turn off the power while an application is running. Doing so could cause loss of data.*
- *Never turn off the power, disconnect an external storage device or remove storage media during data read/write. Doing so can cause data loss.*
- *In any emergency case, you can also press and hold Power button for about 10 seconds to force power off.*

3. Tap the **Settings** charm.
4. Tap **Power** and then select **Shut down**. Or press and hold the power button for about 2-10 seconds till the screen shows **Slide to shut down your PC** appears and then slide down the screen to shut down the tablet.
5. Turn off any peripheral devices connected to your tablet.



Do not turn the tablet or peripheral devices back on immediately - wait a short period to avoid any potential damage.

Restarting the tablet

Certain conditions require that you reset the tablet, for example if:

- You change certain tablet settings.

If you need to restart the tablet, tap **Power** and then select **Restart** in the **Settings** charm.

Sleep Mode

If you have to interrupt your work, you are able to turn off the power without exiting from your software by placing the tablet into Sleep Mode. In this mode data is maintained in the tablet's main memory so that when you turn on the power again, you can continue working right where you left off.



Your system supports Connected Standby function, which starts working after your tablet goes into Sleep Mode. Connected Standby function is to provide a constant connectivity while delivering long battery life, and at the same time, some activities are allowed to run to ensure that the supported Connected Standby scenarios (for example, receiving emails, updating tiles alive with fresh content, downloading/uploading a file from/to a website, and playing music) are functioning properly.



When you have to turn off your tablet aboard an aircraft or in places where electronic devices are regulated or controlled, always completely shut down the tablet. This includes turning off any wireless communication functionalities, and cancelling settings that reactivate the tablet automatically, such as a timer recording function. Failure to completely shut down the tablet in this way could allow the operating system to reactivate and run pre-programmed tasks or preserve unsaved data, which could interfere with aviation or other systems, possibly causing serious injury.



- *Before entering Sleep Mode, be sure to save your data.*
- *Do not switch to Sleep Mode while transferring data to external media, such as USB devices, memory media or other external memory devices. Data will be lost.*



- *When the AC adaptor is connected, the tablet will go into Sleep Mode according to the settings in the Power Options (to access it, tap **Desktop Assist -> Control Panel -> System and Security -> Power Options** on the desktop).*
- *To restore the operation of the tablet from Sleep Mode, press the power button.*
- *If the tablet enters Sleep Mode while a network application is active, the application might not be restored when the tablet is next turned on and the system returns from Sleep Mode.*

-
- *To prevent the tablet from automatically entering Sleep Mode, disable Sleep Mode within the Power Options.*

Benefits of Sleep Mode

The Sleep Mode feature provides the following benefits:

- Restores the previous working environment more rapidly than the Hibernation Mode feature.
- Saves power by shutting down the system when the tablet receives no input or hardware access for the time period set by the System Sleep Mode feature.

Executing Sleep Mode

You can enter Sleep Mode in one of following ways:

- In the **Settings** charm, tap **Power** and then select **Sleep**.
- Press the power button. Please note that this feature must be enabled within the Power Options.

When you turn the power back on, you can continue where you left off when you shut down the tablet.

Sleep Mode limitations

Sleep Mode will not function under the following conditions:

- Power is turned back on immediately after shutting down.
- Memory circuits are exposed to static electricity or electrical noise.

Hibernation Mode

The Hibernation Mode feature saves the contents of memory to the internal storage when the tablet is turned off so that, the next time it is turned on, the previous state is restored. Please note that the Hibernation Mode feature does not save the status of any peripheral devices connected to the tablet.



- *Save your data. While entering Hibernation Mode, the tablet saves the contents of memory to the internal storage. However, for safety sake, it is best to save your data manually.*
- *Data will be lost if you disconnect the AC adaptor before the save is completed.*

Automatic Hibernation Mode

The tablet can be configured to enter Hibernation Mode automatically when battery power is exhausted to the point that tablet operation cannot be continued. This can be specified in the Power Options. In order to define this setting, you can follow the steps as described below:

-
1. Tap **Desktop Assist -> Control Panel -> System and Security -> Power Options -> Change when the computer sleeps -> Change advanced power settings** on the desktop.
 2. Tap **Low battery action** or **Critical battery action** under **Battery** and then select **Hibernate** from the list with the condition of **On battery** or **Plugged in**.

Benefits of Hibernation Mode

The Hibernation Mode feature provides the following benefits:

- Saves data to the internal storage when the tablet automatically shuts down because of a low battery condition.
- You can return to your previous working environment immediately when you turn on the tablet.
- Saves power by shutting down the system when the tablet receives no input or hardware access for the time period set by the System Hibernate feature.

Chapter 3

The Grand Tour

This chapter identifies the various components of the tablet - it is recommended that you become familiar with each before you operate the tablet.

Legal Footnote (Non-applicable Icons)

For more information regarding Non-applicable Icons, please refer to the [Legal Footnotes](#) section.



Please handle your tablet carefully to avoid scratching or damaging the surface.

The Grand Tour for WT10-A

The following figure shows each important component of the tablet.

Figure 3-1 Grand tour of the tablet (WT10-A)

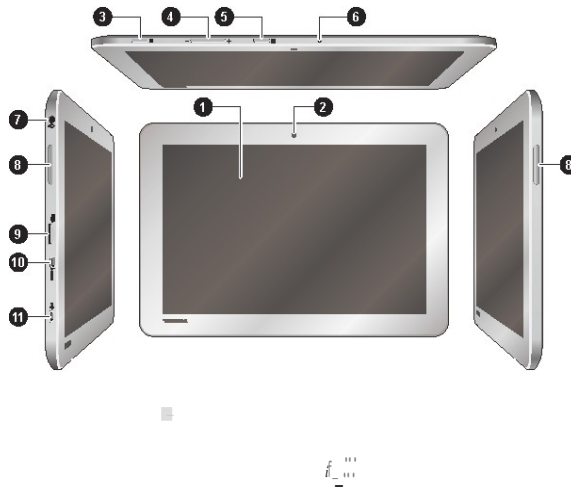

- | | |
|------------------------------------|---|
| 1_ Display screen | 8_ Speakers |
| 2_ Web Camera (ont) | 9_ Memory media slot |
| 3_ Powerbutton | 10_ Micro HDMI port |
| 4_ Volume up/dáNn butlon | 11_ Micro-USB port |
| 5_ Windows butlon | 12_ Strap hole for pen |
| 6_ Microphone | 13_ <i>leb</i> Camera (back) |
| 7_ Headphone/Microphone combo jack | 14_ lireless communication antennas (not shown) |

Product appearance depends on the model you purchased

Display screen 25_6cm (10_1") LCD screen configured with the following resolutions

- HD1280 horizontal x 800 vertical pixels

Please be aware that when the tablet is operating on the AC adaptor the image displayed on the internal screen will be somewhat brighter than when it operates on battery power. This difference in brightness levels is intended to save power when operating on battery

Legal Footnote (LCD)

For more information regarding LCD, please refer to the [Legal Footnotes](#) section.

Web Camera (front) **Web Camera** is a device that allows you to record video or take photographs with your tablet. You can use it for video chatting or video conferences using a communication tool.



- *Do not point the web camera directly at the sun.*
- *Do not touch or press strongly on the web camera lens. Doing so may reduce image quality. Use an eyeglass cleaner (cleaner cloth) or other soft cloth to clean the lens if it becomes dirty.*



Power button Press and hold this button to turn on/off the tablet.

Volume up/down button Press the button to increase or decrease the volume.



Windows button Press this button to open the Start screen or, if already on the Start screen, returns you to your last app.

Microphone The built-in microphone allows you to import and record sounds for your application - please refer to the [Sound System and Video mode](#) section for more information.



Headphone/Microphone combo jack A 3.5 mm mini headphone/microphone combo jack enables connection of a monaural microphone or a stereo headphone.





Speakers The speakers emit sound generated by your software as well as audio alarms, such as low battery condition, generated by the system.



Memory media slot This slot lets you insert a micro SD™/SDHC™/SDXC™ memory card. Refer to the [Memory media](#) section for more information.



Keep foreign metal objects, such as screws, staples and paper clips, out of the Memory media slot. Foreign metal objects can create a short circuit, which can cause damage and fire, possibly resulting in serious injury.

	Micro HDMI port	The micro HDMI port can connect to HDMI cable with Type D connector. An HDMI cable sends video and audio signals.
	Micro-USB port	The tablet acts as a host via this port. When acting as a host, the tablet can fast and directly communicate with other client devices without the assistance of a computer. Please refer to the USB device section for more details.
	<ul style="list-style-type: none"> ■ <i>Please note that it is not possible to confirm the operation of all functions of all USB devices that are available. Some functions associated with a specific device might not operate properly.</i> ■ <i>The Micro-USB port does not support external optical disc drive without its own power adapter.</i> 	
	<i>Keep foreign metal objects, such as screws, staples and paper clips, out of the Micro-USB port. Foreign metal objects can create a short circuit, which can cause damage and fire, possibly resulting in serious injury.</i>	
	Strap hole for pen	This hole is used for hanging your pen with a rope.
	Web Camera (back)	Your tablet is also equipped with a back Web Camera used for recording video or taking photographs.
	<ul style="list-style-type: none"> ■ <i>Do not point the web camera directly at the sun.</i> ■ <i>Do not touch or press strongly on the web camera lens. Doing so may reduce image quality. Use an eyeglass cleaner (cleaner cloth) or other soft cloth to clean the lens if it becomes dirty.</i> 	
	Wireless communication antennas	The tablet is equipped with the Wireless LAN and Bluetooth antennas.

The Grand Tour for WT8-B

The following figure shows each important component of the tablet.

Figure 3-2 Grand tour of the tablet (WT8-B)

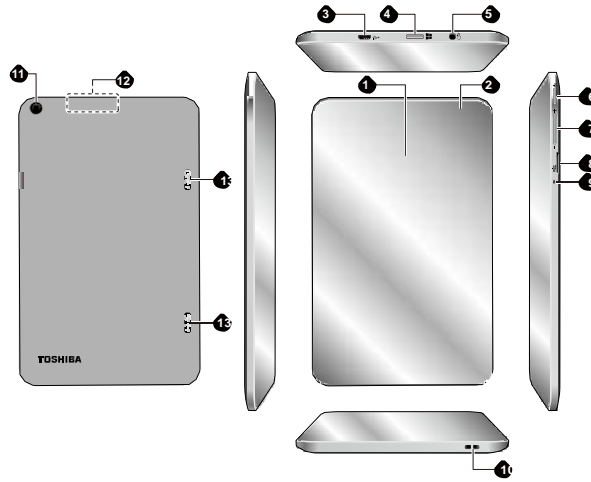

- 1. Display screen
- 2. Web Camera (front)
- 3. Micro-USB port
- 4. Windows button
- 5. Headphone/Microphone combo jack
- 6. Power button
- 7. Volume up/down button
- 8. Memory media slot
- 9. Microphone
- 10. Strap hole for pen
- 11. Web Camera (back)
- 12. Wireless communication antennas (not shown)
- 13. Speakers

Product appearance depends on the model you purchased.

Display screen

20.3cm (8") LCD screen, configured with the following resolutions:

- HD, 800 horizontal x 1280 vertical pixels

Please be aware that, when the tablet is operating on the AC adaptor, the image displayed on the internal screen will be somewhat brighter than when it operates on battery power. This difference in brightness levels is intended to save power when operating on battery.

Legal Footnote (LCD)

For more information regarding LCD, please refer to the [Legal Footnotes](#) section.

Web Camera (front)

Web Camera is a device that allows you to record video or take photographs with your tablet. You can use it for video chatting or video conferences using a communication tool.



- Do not point the web camera directly at the sun.
- Do not touch or press strongly on the web camera lens. Doing so may reduce image quality. Use an eyeglass cleaner (cleaner cloth) or other soft cloth to clean the lens if it becomes dirty.

**Micro-USB port**

The tablet acts as a host via this port. When acting as a host, the tablet can fast and directly communicate with other client devices without the assistance of a computer.

Please refer to the [USB device](#) section for more details.



- Please note that it is not possible to confirm the operation of all functions of all USB devices that are available. Some functions associated with a specific device might not operate properly.
- The Micro-USB port does not support external optical disc drive without its own power adapter.



Keep foreign metal objects, such as screws, staples and paper clips, out of the Micro-USB port. Foreign metal objects can create a short circuit, which can cause damage and fire, possibly resulting in serious injury.

**Windows button**

Press this button to open the Start screen or, if already on the Start screen, returns you to your last app.

**Headphone/
Microphone combo
jack**

A 3.5 mm mini headphone/microphone combo jack enables connection of a monaural microphone or a stereo headphone.

**Power button**

Press and hold this button to turn on/off the tablet.

**Volume up/down
button**

Press the button to increase or decrease the volume.

**Memory media slot**

This slot lets you insert a micro SD™/SDHC™/SDXC™ memory card. Refer to the [Memory media](#) section for more information.



Keep foreign metal objects, such as screws, staples and paper clips, out of the Memory media slot. Foreign metal objects can create a short circuit, which can cause damage and fire, possibly resulting in serious injury.

Microphone	The built-in microphone allows you to import and record sounds for your application - please refer to the Sound System and Video mode section for more information.
Strap hole for pen	This hole is used for hanging your pen with a rope.
Web Camera (back)	Your tablet is also equipped with a back Web Camera used for recording video or taking photographs.



- *Do not point the web camera directly at the sun.*
- *Do not touch or press strongly on the web camera lens. Doing so may reduce image quality. Use an eyeglass cleaner (cleaner cloth) or other soft cloth to clean the lens if it becomes dirty.*

Wireless communication antennas	The tablet is equipped with the Wireless LAN and Bluetooth antennas.
Speakers	The speakers emit sound generated by your software as well as audio alarms, such as low battery condition, generated by the system.

Internal Hardware Components

This section describes the internal hardware components of your tablet. The actual specifications may vary depending on the model you purchased.

Battery pack	<p>This tablet includes one battery pack inside. However, please do not attempt to dismount or replace it by yourself. Please contact an authorized TOSHIBA service provider, if necessary.</p> <p>The rechargeable lithium-ion battery pack provides power to the tablet when the AC adaptor is not connected.</p> <p>For more detailed information on the use and operation of the battery pack please refer to the Battery section.</p>
---------------------	--

Legal Footnote (Battery Life)

For more information regarding Battery Life, please refer to the [Legal Footnotes](#) section.

CPU

The processor type varies depending on model. To check which type of processor is included in your model, tap **Desktop Assist -> Control Panel -> System and Security -> System** on the desktop.

Legal Footnote (CPU)

For more information regarding CPU, please refer to the [Legal Footnotes](#) section.

Video RAM

The memory in a tablet's graphics adaptor, used to store the image displayed on a bitmap display. The amount of Video RAM available is dependent on the tablet's system memory.

Tap **Desktop Assist -> Control Panel -> Appearance and Personalization -> Display -> Adjust resolution** on the desktop.

The amount of Video RAM can be verified by tapping the **Advanced settings** button in the Screen Resolution window.

Memory

This tablet may be equipped with a 1GB or 2GB memory on board depending on the model. The actual amount of usable system memory will be less than the installed memory modules. This tablet does not support memory expansion.

Legal Footnote (Memory (Main System))

For more information regarding Memory (Main System), please refer to the [Legal Footnotes](#) section.

Graphics Processing Unit

Graphics processing unit (GPU) performance may vary depending on product model, design configuration, applications, power management settings and features utilized. GPU performance is only optimized when operating in AC power mode and may decrease considerably when operating in battery power mode.

Legal Footnote (Graphics Processing Unit (GPU))

For more information regarding Graphics Processing Unit (GPU), please refer to the [Legal Footnotes](#) section.

Chapter 4

Operating Basics

This chapter describes the basic operations of your tablet, and highlights the precautions that should be taken when using it.

Using the Touch Screen

You can use your finger to manipulate icons, buttons, menu items, the onscreen keyboard, and other items on the touch screen.



Tap

Simply tap your finger once on the touch screen to activate an item, such as an app.



Press and hold

Press your finger down and leave it there for a few seconds. This will show information to help you learn more about an item or will open a menu specific to what you are doing.



Pinch or stretch

Touch the screen or an item with two or more fingers, and then move the fingers toward each other (pinch) or away from each other (stretch). This will show different levels of information or visually zooms in or out.



Rotate

Put two or more fingers on an item and then turn your hand to rotate things in the direction you turn your hand. Only some items can be rotated.



Slide

Drag your finger on the touch screen to move through what's on the screen.



Swipe

Quickly move your finger in from the edge of the screen, without pausing when you first touch it.

Swipe from the left edge: shows your recently opened apps, and so on.

Swipe from the right edge: opens or closes the charms (Search, Share, Start, Devices, Settings).

Swipe from the top edge: opens or closes the app command bar.

For details and more advanced touch screen gestures to interact with Windows operating system, please refer to Help and Support.



- *Do not press or push with excess force on the touch screen.*
- *Do not apply excess force when cleaning the touch screen.*
- *Never touch the screen with a sharp object such as a ball-point pen which may scratch or damage the surface.*
- *Do not use a protecting sheet for the touch screen as it may decrease its sensitivity to gestures.*

3D Playback on an External 3D Device

3D playback on an external 3D device feature is only provided with WT10-A models.

Effect of 3D can be shown only on an external 3D devices connected via an HDMI output. It cannot be shown on the internal display. In order for 3D playback to work on external display/TV, you need a 3D enabled display/TV that has an HDCP compliant HDMI port.



3D playback feature supports the following resolutions: 1920x1080 24Hz and 1280x720 60Hz.

Please change the Screen Resolution to one of the above before using 3D playback function.

Important Safety Information for 3D Function

- Please refrain from or stop viewing if you feel ill or experience discomfort before or while watching 3D video images.
- Please refrain from viewing 3D video images if you experience convulsions, photosensitivity reaction, or heart disease.
- Due to the possibility of impact on vision development, viewers of 3D video images should be aged 6 or older. Children and teenagers may be more susceptible to health issues associated with viewing in 3D and should be closely supervised to avoid prolonged viewing without rest.

-
- Avoid use of the 3D function when under the influence of alcohol.
 - Please read the user's manual that comes with the tablet carefully before using the 3D playback function.
 - The 3D effect differs between individuals.

Battery

This section explains battery types, use, recharging methods and handling.

Battery pack

When the AC adaptor is not connected, the tablet's main power source is this lithium ion battery pack, also referred to in this manual as the main battery.

Real Time Clock (RTC) function

The Real Time Clock (RTC) function is supported. The main battery provides power for the internal real time clock and calendar function and also maintains the system configuration while the tablet is turned off. If the RTC lasting time completely runs out, the system will lose this information and the real time clock and calendar will stop working.

You can change the Real Time Clock settings in the BIOS setup utility. Please refer to [Troubleshooting](#) for further information.

Care and use of the battery pack

This section provides the important safety precautions in order to handle your battery pack properly.

Refer to the enclosed **Instruction Manual for Safety and Comfort** for detailed precautions and handling instructions.



- *The battery pack can explode if not used, handled or disposed of properly. Dispose of the battery as required by local ordinances or regulations.*
- *Charge the battery pack only in an ambient temperature between 5 and 35 degrees Celsius. Otherwise, the electrolyte solution might leak, battery pack performance might deteriorate and the battery life might be shortened.*

Charging the battery

When the power in the battery pack becomes low, the tablet will enable Hibernation Mode so that you do not lose any data, and automatically turn itself off.

You must recharge a battery pack when it becomes discharged.

Procedures

To recharge the battery pack, connect the AC adaptor to the Micro-USB port on the tablet and plug the other end into a working outlet.



Use only the tablet connected to an AC power source or optional TOSHIBA Battery charger to charge the battery pack. Never attempt to charge the battery pack with any other charger.

Charging Time

The following table shows the approximate time required to fully charge a discharged battery.



Please be aware that the charging time when the tablet is on is affected by ambient temperature, the temperature of the tablet and how you are using the tablet - if you make heavy use of external devices for example, the battery might scarcely charge at all during operation.

Charging time for WT10-A

Battery type	Power off	Power on
Battery pack (22.5Wh, 2 cell)	about 6 hours	about 8 hours

Charging time for WT8-B

Battery type	Power off	Power on
Battery pack (15Wh, 1 cell)	about 6 hours	about 8 hours

Battery charging notice

The battery may not begin charging immediately under the following conditions:

- The battery is extremely hot or cold (if the battery is extremely hot, it might not charge at all). To ensure the battery charges to its full capacity, you should charge it at room temperature of between 5°C to 35°C (41°F to 95°F).
- The battery is nearly completely discharged. In this instance you should leave the AC adaptor connected for a few minutes and the battery should begin charging.

The battery may have a rapid decrease in battery operating time when you try to charge a battery under the following conditions:

- The battery has not been used for a long time.
- The battery has completely discharged and been left in the tablet for a long time.

In such cases you should follow the steps as detailed below:

1. Fully discharge the battery by leaving it in the tablet with the power on until the system automatically turns itself off.
2. Connect the AC adaptor to the Micro-USB port of the tablet, and to a wall outlet that is supplying power.
3. Charge the battery until the battery reaches its full capacity.

Repeat these steps two or three times until the battery recovers normal capacity.

Monitoring battery capacity

Remaining battery power can be monitored using the following methods.

- Tapping the battery icon on the Windows Taskbar
- Via the Battery Status in the Windows Mobility Center window



- *Please be aware that the actual remaining operating time may differ slightly from the calculated time.*
- *With repeated discharges and recharges, the battery's capacity will gradually decrease. In view of this it will be noted that an often used, older battery will not operate for as long as a new battery even when both are fully charged.*

Maximizing battery operating time

A battery's usefulness depends on how long it can supply power on a single charge, while how long the charge lasts in a battery depends on:

- Processor speed
- Screen brightness
- System Sleep Mode
- System Hibernation Mode
- Display power off period
- How much charge the battery contained to begin with.
- How you use optional devices, such as a USB device, to which the battery supplies power.
- Whether you enable Sleep Mode, which can conserve battery power if you are frequently turning the tablet off and on.
- Where you store your programs and data.
- The environmental temperature - operating time decreases at low temperatures.

Batteries exhausted time

When you turn off the power of your tablet with battery fully charged, the battery will be exhausted within the following approximate period.

Battery exhausted time for WT10-A

Battery type	Sleep Mode	Shut Down Mode
Battery pack (22.5Wh, 2 cell)	about 10 days	about 6 weeks

Battery exhausted time for WT8-B

Battery type	Sleep Mode	Shut Down Mode
Battery pack (15Wh, 1 cell)	about 6 days	about 6 weeks

Extending battery life

To maximize the life of your battery pack:

At least once a month, disconnect the tablet from a power source and operate it on battery power until the battery pack fully discharges. Before doing so, follow the steps as detailed below.

1. Turn off the tablet's power.
2. Disconnect the AC adaptor and turn on the tablet's power - if it does not turn on then go to Step 4.
3. Operate the tablet on battery power for five minutes. If you find that the battery pack has at least five minutes of operating time, continue operating until the battery pack is fully discharged, however, if there is warning to indicate a low battery condition, go to Step 4.
4. Connect the AC adaptor to the Micro-USB port of the tablet, and to a wall outlet that is supplying power.
5. Charge the battery pack until the battery reaches its full capacity.



The tablet can not be powered on by pressing the power button if the battery power is completely exhausted. It is recommended to charge the battery pack by connecting the AC adaptor for 30 minutes before turning on the power.

GPS Function

Your tablet may include a built-in GPS (Global Positioning System).

The performance of GPS will vary depending on the environment. It might happen that a location cannot be determined.

Your current location may not be shown depending on the status of GPS or the location. If you are obtaining your current location information from the tablet, your current location may not be detected due to the information

accuracy. Specifically, your current location may not be detected in the following places or situations:

- Inside or directly under a building
- Inside a bag or box
- Among dense trees
- When there is an obstacle (person or object) in the front of the antenna
- Underground tunnel, underground, or underwater
- Buildings streets or residential areas
- Near to the high voltage cables
- Bad weather such as heavy rain or snow

Memory media

The tablet is equipped with a memory media slots that can accommodate some kinds of memory media with various memory capacities so that you can easily transfer data from devices, such as digital cameras and Personal Digital Assistants.



Keep foreign objects out of the memory media slot. Never allow metal objects, such as screws, staples and paper clips, to enter the tablet or Keyboard. Foreign metal objects can create a short circuit, which can cause tablet damage and fire, possibly resulting in serious injury.



- *This Memory media slot supports the following memory media: microSD/SDHC/SDXC Card.*
- *Please note that not all memory media have been tested and verified to work correctly. Therefore, it is not possible to guarantee that all memory media will operate properly.*

Figure 4-1 Example of memory media (microSD card)



Points to note about the memory media card

microSD/SDHC/SDXC memory cards comply with SDMI (Secure Digital Music Initiative), which is a technology adopted to prevent unlawful copy or playback of digital music. For this reason, you cannot copy or playback protected material on another tablet or other device, and you may not reproduce any copyrighted material except for your personal enjoyment.

The supported maximum capacity of memory card is 128GB.

Memory media format

New media cards are formatted according to specific standards. If you wish to reformat a media card, be sure to do so with a device that uses media cards.

Formatting a memory media card

Memory media cards are sold already formatted in conformity to specific standards. If you reformat a memory card, be sure to reformat it with a device such as digital camera or digital audio player that uses the memory cards, not with the format command provided within Windows.



Should you need to format all areas of the memory card, including the protected area, you will need to obtain an appropriate application that applies the copy protection system.

Media care

Observe the following precautions when handling the card.

- Do not twist or bend cards.
- Do not expose cards to liquids or store in humid areas or lay media close to containers of liquid.
- Do not touch the metal part of a card or expose it to liquids or let it get dirty.
- After using card, return it to its case.
- The card is designed so that it can be inserted only one way. Do not try to force the card into the slot.
- Do not leave a card partially inserted in the slot. Press the card until you hear it click into place.
- Memory cards have a limited lifespan, so it is important to backup important data.
- Do not write to a card if the battery power is low. Low power could affect writing accuracy.
- Do not remove a card while read/write is in progress.



For more details on using memory cards, see manuals accompanying the cards.

Inserting memory media

The following instructions apply to all types of supported media devices. To insert memory media, follow the steps as detailed below:

1. Turn the memory media so that the contacts (metal areas) face down.
2. Insert the memory media into the memory media slot on the side of the tablet.

3. Press the memory media gently until it clicks into place

Figure 4-2 Inserting memory media (WT10-A)



Figure 4-3 Inserting memory media (WT8-)

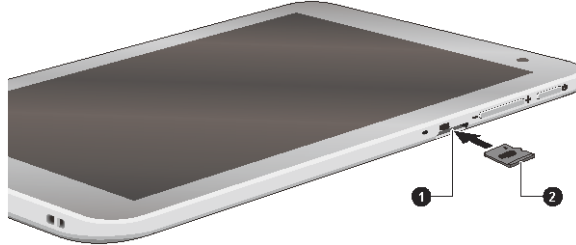

1. Memory media slot

2. Memory media

Product appearance depends on the model you purchased

- Make sure the memory media is oriented properly before you insert it. If you insert the media in wrong direction you may not be able to remove it.
- When inserting the memory media do not touch the metal contacts. You could expose storage area to static electricity which can destroy data.
- Do not turn the tablet off or switch to Sleep Mode or Hibernation Mode while files are being copied - doing so may cause data to be lost.

Removing memory media

The following instructions apply to all types of supported media devices. To remove memory media follow the steps as detailed below

1. Tap the Safely Remove Hardware and Eject Media icon on the Windows Taskbar

2. Tap memory media to eject

3. Push the memory media until you hear a click to partially release it

4. Grasp the media and pull it out of the slot

- If you remove the memory media or turn off the power while the tablet is accessing the memory media you may lose data or damage the media

- *Do not remove the memory media while the tablet is in Sleep or Hibernation Mode. The tablet could become unstable or data in the memory media could be lost.*

USB device

This tablet is equipped with a Micro-USB port that complies with USB 2.0 standard.

You can connect the USB device into the Micro-USB port on your tablet directly or through the USB port on the provided "USB Data and Charge Y-Cable" depending on the USB device.



Make sure the connector is properly aligned with the socket. Do not try to force the connection, doing so can damage the connecting pins.



As the port operation of all USB devices has not been confirmed, some USB devices may not function properly.

Using the "USB Data and Charge Y-Cable"

The "USB Data and Charge Y-Cable" is provided with some models and it can be used for the following scenarios:

- **Charging only**

Charging the tablet as a charging cable connected with the AC adaptor.

- **Charging and Data transfer**

Charging the tablet as a charging cable connected with the AC adaptor and connecting to a standard USB device at the same time.

Figure 4-4 USB Data and Charge Y-Cable (WT10-A for example)

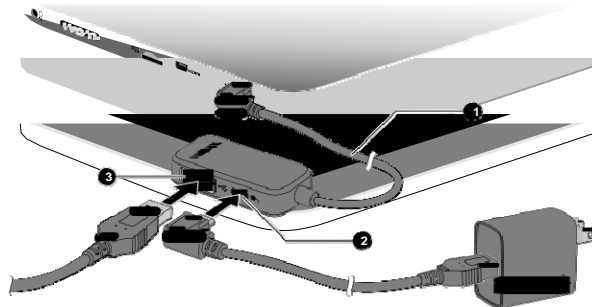

1. USB Data and Charge Y-Cable
2. Micro-USB port (Charge only)

3. Universal Serial Bus (USB 2.0) port

- **Data transfer only**

Connecting to a standard USB device only.



- *Charging the tablet via connecting the "USB Data and Charge Y-Cable" may take longer.*
- *The AC adaptor should not be disconnected with the "USB Data and Charge Y-Cable" if it is connecting with USB device and tablet at the same time. If the USB device works with USB bus power, which comes from "USB Data and Charge Y-Cable", the disconnection of AC adaptor would cause power loss. Even if the USB device has its own power source, the device will stop around 60 milliseconds because USB controller would detect with "no bus power" due to sudden disconnection with AC adaptor. The disconnection may cause data loss and thus Windows may detect error and start data recovery.*
- *Charging the tablet via connecting the "USB Data and Charge Y-Cable" will need 1.5A for charging, and if a USB device is connected to the tablet, it will need 2A for charging. In this case, when charging from PC's USB port which only supports 1A, the power supply may stop working.*
- *Tablets other than WT10-A and WT8-B cannot support "USB Data and Charge Y-Cable".*

External Display

Your tablet video capabilities can be enhanced with additional displays.

External displays allows you to share your desktop or extend the desktop area.

HDMI device

HDMI feature is only provided with WT10-A models.

The tablet is equipped with a Micro HDMI port that can send video by connecting with external devices. Your tablet supports 1080p, 720p signal format. The available format depends on the HDMI device you are connected to.

To connect an HDMI-compatible display device, follow the steps as detailed below:



- *As the port operation of all external display devices have not been confirmed, some devices may not function properly.*
- *To connect a device to the Micro HDMI port, you must purchase a suitable HDMI cable.*

1. Plug one end of the HDMI cable into the HDMI in port of the HDMI display device
2. Plug the other smaller end of the HDMI cable into the Micro HDMI port on your tablet.
3. Turn the HDMI display device's power on.

Figure 4-5 Connecting an HDMI cable

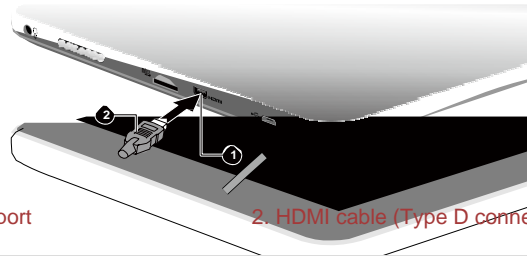

Please do not plug/unplug an HDMI device under the following conditions:

- The system is starting up.
- The system is shutting down.

When you connect a television or external monitor to the Micro HDMI port, the display output device is set to HDMI.

When you unplug the HDMI cable and re-plug it, please wait at least 5 seconds before you re-plug the HDMI cable again.

When you change the display output device, the playback device may not switch automatically. In this case, in order to set the playback device to the same device as the display output device, please adjust the playback device manually by the following steps:

1. Tap **Desktop Assist** -> **Control Panel** -> **Hardware and Sound** -> **Sound** on the desktop.
2. In the **Playback** tab, select the playback device which you want to switch to.
3. To use the internal speakers on your tablet, select **Speakers**. To use the television or the external monitor that you have connected to the tablet, select a different playback device.
4. Tap the **Set Default** button.
5. Tap **OK** to close the **Sound** dialog.

Settings for display video on HDMI

To view video on the HDMI display device, be sure to configure the following settings otherwise you may find that nothing is displayed.



Be sure to select the display device before starting to play video. Do not change the display device while playing video.

Do not change the display device under the following conditions.

- While data is being read or written.
- While communication is being carried out.

Selecting HD Format

To select the display mode, follow the steps as detailed below:

1. Tap **Desktop Assist -> Control Panel -> Appearance and Personalization -> Display -> Change display settings -> Advanced settings -> List All Modes**
2. Select one of the modes at **List All Modes**.

Wireless display

Your tablet supports Wireless display, a wireless technology which utilizes Wi-Fi to allow the tablet to be wirelessly connected to external displays including TVs as extended screens. With Wireless display, documents, streamed/local media contents or other online contents can be shared wirelessly with others.

To use Wireless display, either one of the following devices is required:

- A compatible external display with built-in support for Wireless display.
- An external display with HDMI port and a Wireless display adaptor.

The Wireless display adaptor is a device that connects to the external display via HDMI port and can receive Wi-Fi signals from your tablet.

To wirelessly connect to an external display, you can follow the steps as described below:

1. Tap **Settings** charm.
2. Tap **Change PC settings -> PC and devices -> Devices**.
3. Tap **Add a device**. Your tablet will start searching for the Wireless display device.
4. After the Wireless display device is searched, follow the on-screen instructions to finish connection.

After the connection is established, the name of the Wireless display device will appear under **Projectors**.

To disconnect the Wireless display device, tap the Wireless display device name and then tap **Remove device**.

Changing the display settings

After one or more external displays are connected, the operating system can automatically detect, identify and setup the display settings.

You can also manually manage how the external displays will work and change the display settings by tapping **Projector** in the **Devices** charm. If you disconnect the external display before you turn the tablet's power off, be sure to switch to the internal display.

Optional TOSHIBA Accessories

You are able to add a number of options and accessories in order to make your tablet even more powerful and convenient to use. For reference, the

following list details some of the items that are available from your reseller or TOSHIBA dealer:

Universal AC Adaptor If you frequently use your tablet at more than one site, it may be convenient to purchase an additional AC adaptor to be kept at each site in order to remove the need to always carry the adaptor with you.

Sound System and Video mode

This section describes some of the audio control functions.

Volume Mixer

The Volume Mixer utility lets you control the audio volume for playback of devices and applications under Windows.

- To launch the Volume Mixer utility, tap **Desktop** and press and hold on the speaker icon on the Windows Taskbar, and then select **Open Volume Mixer** from the sub menu.
- To adjust the volume level of speakers or headphones, move the **Speakers** slider.
- To adjust the volume level of an application that you are using, move the slider for the corresponding application.

Microphone Level

Follow the steps below to change the microphone recording level.

1. Press and hold on the speaker icon on the Windows Taskbar, and select **Recording devices** from the sub menu.
2. Select **Microphone**, and tap **Properties**.
3. On the **Levels** tab move the **Microphone** slider to increase or decrease the microphone volume level.

If you feel the microphone volume level is inadequate, move the **Microphone Boost** slider to a higher level.

Video mode

Video mode settings are configured via the **Screen Resolution** dialog.

To open the **Screen Resolution** dialog, tap **Desktop Assist -> Control Panel -> Appearance and Personalization -> Display -> Change display settings** on the desktop.



If you are running some applications (for example a 3D application or video playback), you may see some disturbance, flickering or frame dropping on your screen.

If that cursor adjust the resolution of display lowering it until the screen is displayed properly.

Chapter 5

Utilities and Advanced Usage

This chapter describes the utilities and special features of this tablet, and the advanced usage of some utilities.

Utilities and Applications

This section describes the pre-installed utilities that come with the tablet and details how to start them. For further information on their operation, you may refer to each utility's online manual, help files or README.TXT file (if applicable).

TOSHIBA Desktop Assist	<p>TOSHIBA Desktop Assist is a graphical user interface that provides access to specific tools and TOSHIBA utilities and applications that make the use and configuration of the tablet easier.</p> <p>To access this utility, tap Desktop Assist on the desktop.</p>
TOSHIBA Display Utility	<p>Desktop Text Size allows you to make the text size bigger or smaller on the desktop according to your usage and favorite. You can change the text size on the display and on the title bar of windows by changing the scaling of the text size. When the scaling is smaller, more information will appear on the display simultaneously but the text size becomes smaller. When the scaling is larger, less information will appear on the display simultaneously but the text size becomes larger.</p> <p>To access this utility, tap Desktop Assist -> Tools & Utilities -> Display Utility on the desktop.</p> <p>For details on this utility, see the help file.</p>
TruCapture	<p>This software is a camera application with special features to take improved photographs of whiteboards, books, printed material, notebooks, etc.</p> <p>To access it, tap the TruCapture icon in the Apps view.</p> <p>For details, please refer to the TruCapture section.</p>

TOSHIBA Setup Utility

TOSHIBA Setup Utility is a BIOS setup utility that provides you a menu-based user interface so that you can easily view and change BIOS settings.
For details, please refer to the [TOSHIBA Setup Utility](#) section.

TOSHIBA Service Station

This application allows your tablet to automatically search for TOSHIBA software updates or other alerts from TOSHIBA that are specific to your tablet system and its programs. When enabled, this application periodically transmits to our servers a limited amount of system information, which will be treated in strict accordance with the rules and regulations as well as applicable data protection law.

To access this utility, tap **Desktop Assist -> Support & Recovery -> Service Station** on the desktop.

Dolby® Digital Plus™ Advanced Audio™

Dolby® Digital Plus™ Advanced Audio™ is a suite of audio technologies that enables a PC to deliver a crisp, clear cinematic surround sound experience over its built-in speakers. It also adds clarity to sound from headphones.

To access this utility, tap the **Dolby Digital Plus** icon in the Apps view.



You may not have all the software listed above depending on the model you purchased.

*To access the setup files of the drivers/utilities, tap **Applications and Drivers** in the Apps view.*

Special features

The following features are either unique to TOSHIBA computers or are advanced features which make the computer more convenient to use.

Access each function using the following procedures.

*1 To access the Power Options, tap **Desktop Assist -> Control Panel -> System and Security -> Power Options** on the desktop.

Display automatic power off *1

This feature automatically cuts off power to the computer's display panel when there is no keyboard input for a specified time, with power being restored the next time a key is pressed. This can be specified in the Power Options.

Power on password	Two levels of password security, supervisor and user, are available to prevent unauthorized access to your computer.
Battery save mode *1	This feature lets you configure the computer in order to save battery power. This can be specified in the Power Options.
Low battery automatic Hibernation Mode *1	When battery power is exhausted to the point that computer operation cannot be continued, the system automatically enters Hibernation Mode and shuts itself down. This can be specified in the Power Options.

TruCapture

TruCapture is a camera application with special features to improve the readability of whiteboards, books, etc. in photographs taken by TruCapture. Those features include reflection reduction, color enhancement and cropping.

To open TruCapture, tap **TruCapture** in **Apps view**.

A **Tutorial** will appear on the screen which provides the basic information about how to use this feature.

Tap **next** if you want to continue viewing the **Tutorial**.

For more detailed information on the use of this feature, tap **more information**. You can also find it by swiping from the right edge of the screen, and then tap **Settings -> Help**.

TOSHIBA Setup Utility

TOSHIBA Setup Utility is a BIOS setup utility that provides you a menu-based user interface so that you can easily view and change BIOS settings.

To enter the BIOS setup utility, follow the steps below:

1. Save your work.
2. In the **Settings** charm, tap **Power** and then select **Shut down**.
3. After completely shut down the tablet, wait for about 10 seconds. Then hold down the **Power** button and **Volume down** button simultaneously.



Please make sure that fast startup is disabled in the Power Options by following the steps below:

1. Tap **Desktop Assist -> Control Panel -> System and Security -> Power Options** on the desktop.
2. Tap **Choose what the power button does**.
3. Tap **Change settings that are currently unavailable**.

-
4. Deselect the **Turn on fast startup** check box from Shutdown settings.
 5. Tap the **Save changes** button.

To save the changes and exit the utility, select **Save and Exit -> Exit Saving Changes -> Yes**. The tablet will restart immediately.

Navigating the utility

TOSHIBA Setup Utility can be navigated through the touch screen.

Some buttons on the tablet are also designated to execute the corresponding function. Details are described as follows:

Button	Function
Windows	Proceed or confirm operation
Volume up	Select an item
Volume down	Select an item

System Recovery

There is a hidden partition allocated on the tablet for the System Recovery Options in the event of a problem.

You can also create recovery media and restore the system.

The following items will be described in this section:

- Creating Recovery Media
- Restoring the pre-installed software from your created Recovery Media
- Restoring the pre-installed software from the Recovery Partition

Creating Recovery Media

This section describes how to create Recovery Media.



- *Be sure to connect the AC adaptor when you create Recovery Media.*
- *Be sure to close all other software programs.*
- *Do not run software such as screen savers which can put a heavy load on the CPU.*
- *Operate the tablet at full power.*
- *Do not use power-saving features.*
- *Do not write to the media when the virus check software is running. Wait for it to finish, then disable virus detection programs including any software that checks files automatically in the background.*

- *Do not use utilities, including those intended to enhance internal storage access speed. They may cause unstable operation and damage data.*
- *Do not shut down/log off or Sleep/Hibernate while writing or rewriting the media.*
- *Set the tablet on a level surface and avoid places subjected to vibrations such as airplanes, trains, or cars.*
- *Do not use on an unstable surface such as a stand.*

A recovery image of the software on your tablet is stored on a dedicated recovery partition on your tablet, and can be copied to a USB Flash Memory by using the following steps:



- *To connect a USB Flash Memory to the Micro-USB port, you must purchase a suitable Micro USB to USB Converter Cable.*
- *USB Flash Memory will be formatted and all the data in the USB Flash Memory will be lost when proceeding.*

1. Turn on your tablet and allow it to load the Windows operating system as normal.
2. Insert the USB Flash Memory into Micro-USB port on your tablet by using the Micro USB to USB Converter Cable.
3. Tap **Desktop Assist -> Control Panel -> System and Security -> Action Center -> Recovery -> Create a recovery drive** on the desktop.
4. Follow the on-screen instructions to finish creating the Recovery Media.

Restoring the pre-installed software from your created Recovery Media

If the pre-installed files are damaged, you are able to use the Recovery Media you have created to restore the tablet to the state it was in when you originally received it. To perform this restoration, follow the steps below:



Make sure that the AC adaptor are connected during the restoring process.



When you reinstall the Windows operating system, the storage space will be reformatted and all data will be lost.

1. Insert the recovery USB Flash Memory into Micro-USB port on your tablet by using the the Micro USB to USB Converter Cable.
2. In the **Settings** charm, tap **Power** and then select **Shut down**.

3. After completely shut down the tablet, wait for about 10 seconds. Then hold down the **Power** button and **Volume up** button simultaneously until the Boot menu is loaded.
4. Use the **Volume up** and the **Volume down** button to select the appropriate option from the menu according to your actual recovery media and press the **Windows** button to confirm the selection.
5. A menu will be displayed from which you should follow the on-screen instructions.



- **Refresh, Reset and Bare metal recovery** buttons will be displayed as options for recovery. However, only **Bare metal recovery** is supported when booting from the recovery media. For detailed information, please refer to the *Windows Help and Support*.
- Office will no longer be present after the recovery completes. To enable users to reinstall Office, please follow the instructions described below:
 - If you have a product key for an Office 365 product, you can enter the key at <https://officesetup.getmicrosoftkey.com/>
You can also go directly to your Office Account at <https://office.microsoft.com/MyAccount.aspx> to install.
 - If you have a product key for Office Home and Student, Office Home and Business or Office Professional, you can go to <https://downloadoffice.getmicrosoftkey.com/> to install.



The recovery partition can be removed depending on the model. For the models that the recovery partition can be removed, if you have previously chosen to remove the recovery partition without creating "Recovery Media", the "Recovery Media" cannot be created.

However, if you have already created a "Recovery Media", you can use it to restore the recovery partition.

If you have not created "Recovery Media", please contact TOSHIBA support for assistance.

Restoring the pre-installed software from the Recovery Partition

A portion of the total storage space is configured as a hidden recovery partition. This partition stores files which can be used to restore pre-installed software in the event of a problem.

If you subsequently set up your storage space again, do not change, delete or add partitions in a manner other than specified in the manual, otherwise you may find that space for the required software is not available.

In addition, if you use a third-party partitioning program to reconfigure the partitions on your storage space, you may find that it becomes impossible to setup your tablet.



Make sure that the AC adaptor are connected during the restoring process.



When you reinstall the Windows operating system, the storage space may be reformatted and all data may be lost.

1. In the **Settings** charm, tap **Power** and then select **Shut down**.
2. After completely shut down the tablet, wait for about 10 seconds. Then hold down the **Power** button and **Volume up** button simultaneously until the Boot menu is loaded and then select **HDD Recovery**.
3. A dialog box will appear asking if you are sure you want to continue. Select **Yes**.
4. Select **Troubleshoot**.
5. Select **Reset your PC**.
6. Follow the on screen instructions to finish the recovery.

You can also perform the restoration through PC settings in the operating system:

1. Tap the **Settings** charm and tap **Change PC settings**.
2. Tap **Update and recovery** under PC settings and then tap **Recovery**.
3. Click **Get started** under **Remove everything and reinstall Windows**.
4. Follow the on screen instructions to finish the recovery.

Enabling System Protection for System Restore

Depending upon your system, the Windows® System Protection feature, that automatically creates restore points, may be disabled to conserve space on your system. You can enable this feature by the following steps:

1. Tap **Desktop Assist -> Control Panel -> System and Security -> System -> System protection** on the desktop.
2. In the **System Protection** tab, tap **Configure**, and then tap **Turn on system protection** to enable the function.

After the **System Protection** feature is enabled, you can undo changes by reverting your tablet to a previous state by creating a restore point.

Troubleshooting

TOSHIBA has designed this computer for durability, however, should problems occur you are able to use the procedures detailed in this chapter to help determine the cause.

All users should become familiar with this chapter as knowing what might go wrong can help prevent problems from occurring in the first place.

Problem solving process

Resolving problems will be much easier if you observe the following guidelines:

- Stop immediately when you recognize a problem exists as taking further action may result in data loss or damage, or you may destroy valuable problem related information that can help solve the problem.
- Observe what is happening - write down what the system is doing and what actions you performed immediately before the problem occurred. Make a screenshot of the current display.

Please also be aware that the questions and procedures described in this chapter are meant only as a guide, they are not definitive problem solving techniques. In reality many problems can be solved simply, but a few may require help from TOSHIBA Support - if you find you need to consult others, be prepared to describe the problem in as much detail as possible.

Preliminary checklist

You should always consider the simplest solution first - the items detailed in this checklist are easy to fix and yet can cause what appears to be a serious problem:

- Make sure you turn on all peripheral devices before you turn on the computer - this includes your printer and any other external device you are using.
- Before you attach an external device you should first turn the computer off, then when you turn the computer back on again it will recognize the new device.
- Make sure all optional accessories are configured properly in the computer's setup program and that all required driver software has been loaded (please refer to the documentation included with the optional accessories for further information on its installation and configuration).

-
- Check all cables to ensure they are correctly and firmly attached to the computer - loose cables can cause signal errors.
 - Inspect all connecting cables for loose wires and all connectors for loose pins.

Always try to make detailed notes of your observations and keep them in a permanent error log - this will help you to describe your problems to TOSHIBA Support. In addition, if a problem recurs, the log you have made will help to identify the problem faster.

Analyzing the problem

Sometimes the computer will give you clues that can help you identify why it is malfunctioning. In view of this you should keep the following questions in mind:

- Which part of the computer is not operating properly - keyboard, Hard Disk Drive, display panel, Touch Pad, Touch Pad control buttons - as each device will produce different symptoms.
- Check the options within the operating system to ensure that its configuration is set properly.
- What appears on the display? Does it display any messages or random characters? Make a screenshot of the current display and, if possible, look up the messages in the documentation included with the computer, software or operating system.
- Check that all connecting cables are correctly and firmly attached as loose cables can cause erroneous or intermittent signals.
- Do you hear any beeps, if so how many, are they long or short and are they high pitched or low pitched? In addition, is the computer making any unusual noises? Write down what you hear.

Record your observations so you can describe them in detail to TOSHIBA Support.

Software

The problems may be caused by your software. If you cannot load a software package, the media may be damaged or the program might be corrupted - in these instances try loading another copy of the software if possible.

If an error message appears while you are using a software package you should refer to the documentation supplied with it as this will usually include a problem solving section or a summary of error messages.

Next, you should check any error messages against the operating system documentation.

Hardware

If you cannot find a software problem, you should then check the setup and configuration of your hardware. First run through the items in the preliminary checklist as described previously then, if you still cannot correct the problem, try to identify the source - the next section provides checklists for individual components and peripherals.



Before using a peripheral device or application software that is not an authorized TOSHIBA part or product, make sure the device or software can be used with your computer. Use of incompatible devices may cause injury or may damage your computer.

If something goes wrong

Your program stops responding

If you are working with a program that suddenly freezes all operations, chances are the program has stopped responding. You can exit the failed program without shutting down the operating system or closing other programs.

To close a program that has stopped responding:

1. Press and hold the Windows Taskbar, and then select **Task Manager** from the sub menu. The Windows Task Manager window appears.
2. Select the program you want to close, then tap **End Task**. Closing the failed program should allow you to continue working. If it does not, continue with the next step.
3. Close the remaining programs one by one by selecting the program name, then **End Task**. Closing all programs should allow you to continue working. If it does not, power off your computer and then restart it.

The computer will not start

Make sure you attached the AC adaptor and power cord/cable properly.

If you are using the AC adaptor, check that the wall outlet is working by plugging in another device, such as a lamp.

Verify that the computer is on.

Also, try turning the computer off and then on.

If you are using an AC adaptor, verify that the computer is receiving power from the external power source.

The computer will not load advanced options during startup

The advanced option will be loaded when you hold down the following buttons as described during startup.

Advanced option	Key & button operations
BIOS utility	Hold down Power button and Volume down button simultaneously.
Boot menu	Hold down Power button and Volume up button simultaneously.

If your computer starts to load the Operating System instead of desired advanced options, follow the steps below:



Please make sure that fast startup is disabled in the Power Options by following the steps below:

1. Tap **Desktop Assist** -> **Control Panel** -> **System and Security** -> **Power Options** on the desktop.
2. Tap **Choose what the power button does**.
3. Tap **Change settings that are currently unavailable**.
4. Deselect the **Turn on fast startup** check box from **Shutdown settings**.
5. Tap the **Save changes** button.

1. In the **Setting** charm, tap **Power** and then select **Restart**.
2. Hold down the corresponding buttons until the advanced option is loaded.
3. Follow the on-screen instructions to proceed.

Hardware and system checklist

This section discusses problems caused by your computer's hardware or attached peripherals. Basic problems may occur in the following areas:

- Power
- Internal display panel
- Memory Media Card
- USB device
- Sound system
- External monitor
- Wireless LAN
- Bluetooth

Power

When the computer is not plugged into an AC power outlet, the battery pack is the primary power source. Your computer also has Real Time Clock (RTC) function. All of the power resources are interrelated with anyone having the ability to produce apparent power problems.

Overheating power down

If the processor's temperature reaches an unacceptably high level with either setting, the computer will automatically shut down to prevent any damage - in this instance all unsaved data in memory will be lost.

Problem	Procedure
Computer shuts down automatically.	Leave the computer off until it reaches the room temperature. If the computer has reached room temperature and it still does not start, or if it starts but shuts down quickly, contact TOSHIBA Support.

AC power

Problem	Procedure
AC adaptor doesn't power the computer	<p>Check the connections to make sure that the cable/adaptor is firmly connected to the computer and a working power outlet.</p> <p>Check the condition of the cable and terminals. If the cable is frayed or damaged it should be replaced, while if the terminals are soiled, they should be cleaned with a clean cotton cloth.</p> <p>If the AC adaptor still does not power the computer, you should contact TOSHIBA Support.</p>

Battery

Problem	Procedure
Battery doesn't power the computer	The battery may be discharged - connect the AC adaptor to recharge the battery.
Battery doesn't charge when the AC adaptor is attached.	If the battery is completely discharged, it will not begin charging immediately, in these instances you should wait a few minutes before trying again. If the battery still does not charge, you should check that the power outlet the AC adaptor is connected to is supplying power - this can be tested by plugging another appliance into it.
Battery doesn't power the computer as long as expected	Battery doesn't power the computer as long as expected

Real Time Clock

Problem	Procedure
The BIOS setting and system date/time are lost.	<p>The lasting time of the Real Time Clock (RTC) has run out - you will need to set the date and time in the BIOS setup utility by using the following steps:</p> <ol style="list-style-type: none">1. Launch the BIOS setup utility. Please refer to TOSHIBA Setup Utility section for further information.2. Set the date in the System Date field.3. Set the time in the System Time field.4. Select Save and Exit -> Exit Saving Changes- a confirmation message will be displayed.5. Select Yes - the BIOS setup utility will end and the computer will restart.

Internal display panel

Apparent computer's display panel problems may be related to the computer's setup and configuration.

Problem	Procedure
Markings appear on the computer's display panel.	<p>These marks may have come from contact with touch screen. You should try to remove the marks by gently wiping the display panel with a clean dry cloth or, if this fails, with a good quality LCD screen cleaner. In this latter instance you should always follow the instructions with the screen cleaner and always ensure you let the display panel dry properly.</p>

Memory Media Card

For further information, please refer to [Operating Basics](#).

Problem	Procedure
Memory media card error occurs	<p>Remove the memory media card from the computer and then reinsert it in order to ensure it is firmly connected.</p> <p>If the problem persists, then you should refer to the documentation supplied with your memory media card for further information.</p>

Problem	Procedure
You cannot read a file	Check to ensure the required file is actually on the memory media card that is inserted into the computer. If you are still unable to resolve the problem, contact TOSHIBA Support.

USB device

In addition to the information in this section, please also refer to the documentation supplied with your USB device.

Problem	Procedure
USB device does not work	Remove the USB device from the computer and then reconnect it to the Micro-USB port in order to ensure it is firmly attached. Ensure that any required USB device drivers are properly installed - to achieve this you should refer to both the device documentation and the operating system documentation.

Sound system

In addition to the information in this section, please also refer to the documentation supplied with your audio device.

Problem	Procedure
No sound is heard	Adjust the volume. Check the software volume settings. Please check to see if Mute is turned to Off Check to make sure the headphone connection is secure. Check within the Windows Device Manager application to ensure the sound device is enabled and that the device is properly working.

Problem	Procedure
Annoying sound is heard	<p>In this instance you may be experiencing feedback from either the internal microphone or an external microphone connected to the computer - please refer to Sound System and Video mode for further information.</p> <p>Volume cannot be adjusted during Windows start up or shut down.</p> <p>If you are still unable to resolve the problem, contact TOSHIBA Support.</p>

External monitor

Please also refer to [Operating Basics](#), and to the documentation supplied with your monitor for further information.

Problem	Procedure
Monitor does not turn on	<p>After confirming that the monitor's power switch is on, you should check the connections to make sure that the cable/adaptor is firmly connected to the monitor and to a working power outlet.</p>
No display	<p>Try adjusting the contrast and brightness controls on the external monitor.</p> <p>Change the display priority and ensure that it is not set for the internal display only.</p> <p>Check to see if the external monitor is connected.</p> <p>When the external monitor is set as the primary display device in extended desktop mode, it will not display when the computer wakes up from Sleep Mode if the external monitor has been disconnected while in Sleep Mode.</p> <p>To keep this from happening, do not disconnect the external monitor while the computer is in Sleep or Hibernation Mode.</p> <p>Remember to turn off the computer before disconnecting the external monitor.</p> <p>When the display panel and an external monitor are set to clone mode and they are turned off by the timer, the display panel or the external monitor may not display when turned on again.</p> <p>If this occurs, re-set the display panel and external monitor to clone mode.</p>

Problem	Procedure
Display error occurs	Check that the cable connecting the external monitor to the computer is firmly attached. If you are still unable to resolve the problem, contact TOSHIBA Support.

Wireless LAN

Problem	Procedure
Cannot access Wireless LAN	Make sure the computer's Wireless communication function is on. If problems persist, contact your LAN administrator.

Bluetooth

Problem	Procedure
Cannot access Bluetooth device	Check to ensure the computer's Wireless Communication function is on. Check to ensure the Bluetooth Manager application is running on the computer and that power to the external Bluetooth device is turned on. Check to ensure that no optional Bluetooth Adaptor is installed in the computer - the built-in Bluetooth hardware cannot operate simultaneously with another Bluetooth controller. If you are still unable to resolve the problem, contact TOSHIBA Support.

TOSHIBA support

If you require any additional help using your computer or if you are having problems operating the computer, you may need to contact TOSHIBA for additional technical assistance.

Before you call

Some problems you experience may be related to software or the operating system so it is important that you investigate other sources of assistance first. Before contacting TOSHIBA, try the following:

- Review troubleshooting sections in the documentation supplied with your software and/or peripheral devices.

-
- If a problem occurs when you are running software applications, consult the software documentation for troubleshooting suggestions and consider calling the software company's technical support department for assistance.
 - Consult the reseller or dealer from where you purchased your computer and/or software - they are your best resource for current information and support.

TOSHIBA technical support

If you are still unable to solve the problem and suspect that it is hardware related, visit TOSHIBA technical support website <http://www.toshiba.co.jp/worldwide/>

Appendix

Specifications

This section summarizes the tablet's technical specifications.

Physical Dimensions

Physical Dimensions shown below do not include parts that extend beyond the main body. The physical dimensions may vary depending on the model you purchased.

WT10-A	Approximately 258.8 (w) x 175 (d) x 8.98 (h) millimeters (not including parts that extend beyond the main body).
WT8-B	Approximately 132 (w) x 210.62 (d) x 9.48 (h) millimeters (not including parts that extend beyond the main body).

Environmental Requirements

Conditions	Ambient temperature	Relative humidity
Operating	5°C (41°F) to 35°C (95°F)	20% to 80% (noncondensing)
Non-operating	-20°C (-4°F) to 60°C (140°F)	10% to 90% (noncondensing)
Wet-bulb temperature	29°C maximum	

Conditions	Altitude (from sea level)
Operating	-60 to 3,000 meters
Non-operating	-60 to 10,000 meters maximum

Power Requirements

AC adaptor	100-240V AC 50 or 60 Hz (cycles per second)
Computer	5V DC

AC Power Cord and Connectors

The power cord's AC input plug must be compatible with the various international AC power outlets and the cord must meet the standards for the country/region in which it is used. All cords must meet the following specifications:

Wire size:	Minimum 0.75 mm ²
Current rating:	Minimum 2.5 amperes

Certification agencies

China:	CQC		
U.S. and Canada:	UL listed and CSA certified No. 18 AWG, Type SVT or SPT-2		
Australia:	AS		
Japan:	DENANHO		
Europe:			
Austria:	OVE	Italy:	IMQ
Belgium:	CEBEC	The Netherlands:	KEMA
Denmark:	DEMKO	Norway:	NEMKO
Finland:	FIMKO	Sweden:	SEMKO
France:	LCIE	Switzerland:	SEV
Germany:	VDE	United Kingdom:	BSI

In Europe, two conductors power cord must be VDE type, H05VVH2-F or H03VVH2-F and for three conductors power cord must be VDE type, H05VV-F.

For the United States and Canada two pin plug configuration must be a 2-15P (250V) or 1-15P (125V) and three pin plug configuration must be 6-15P (250V) or 5-15P (125V) as designated in the U.S. National Electrical code handbook and the Canadian Electrical Code Part II

The following illustrations show the plug shapes for the U.S.A. and Canada the United Kingdom Australia Europe and China

USA	United Kingdom
	
UL approved	BS approved
Australia	Europe
AS approved	Approved by the appropriate agency
Canada	China
CSA approved	CCC approved

Information for Wireless Devices

Wireless Technology Interoperability

The Wireless LAN is compatible with other LAN systems Direct Sequence Spread Spectrum (DSSS) IOrthogonal Frequency Division Multiplexing (OFDM) radio technology and is compliant to

- The IEEE 802.11 Standard on Wireless LANs (Revision a!b/g/nb/g/n or Revision a/b/g/n/ac) as defined and approved by the Institute of Electrical and Electronics Engineers

Bluetooth® Modules are designed to be interoperable with any product with Bluetooth wireless technology that is based on Frequency Hopping Spread Spectrum (FHSS) radio technology and is compliant to

- Bluetooth Specification (depending on the model you purchased) as defined and approved by the Bluetooth Special Interest Group
- Logo certification with Bluetooth wireless technology as defined by the Bluetooth Special interest Group

This Bluetooth product is not compatible with devices using Bluetooth Version 1.0B specifications



The wireless devices have not completed verification of connection and operation with all devices which are using the Wireless LAN or Bluetooth radio technology.

Bluetooth and Wireless LAN devices operate within the same radio frequency range and may interfere with one another. If you use Bluetooth and Wireless LAN devices simultaneously, you may occasionally experience a less than optimal network performance or even lose your network connection.

If you should experience any such problem, immediately turn off either one of your Bluetooth or Wireless LAN.

Please visit

<http://www.pc.support.global.toshiba.com> , if you have any questions about using Wireless LAN or Bluetooth Module.

In Europe visit

<http://www.toshiba-europe.com/computers/tnt/bluetooth.htm>

Wireless Devices and your health

Wireless products, like other radio devices, emit radio frequency electromagnetic energy. The level of energy emitted by Wireless products however is far much less than the electromagnetic energy emitted by wireless devices like for example mobile phones.

Because Wireless products operate within the guidelines found in radio frequency safety standards and recommendations, TOSHIBA believes Wireless products are safe for use by consumers. These standards and recommendations reflect the consensus of the scientific community and result from deliberations of panels and committees of scientists who continually review and interpret the extensive research literature.

In some situations or environments, the use of Wireless products may be restricted by the proprietor of the building or responsible representatives of the organization. These situations may for example include:

- Using the Wireless products equipment on board of airplanes, or
- In any other environment where the risk of interference to other devices or services is perceived or identified as harmful.

If you are uncertain of the policy that applies on the use of wireless devices in a specific organization or environment (e.g. airports), you are encouraged to ask for authorization to use the Wireless device prior to turning on the equipment.

Wireless LAN Technology

The computer's wireless communication function supports some wireless communication devices.

Only some models are equipped with both Wireless LAN and Bluetooth functions.



- *Do not use the Wireless LAN (Wi-Fi) or Bluetooth functionalities near a microwave oven or in areas subject to radio interference or magnetic fields. Interference from a microwave oven or other source can disrupt Wi-Fi or Bluetooth operation.*
- *Turn all wireless functionalities off when near a person who may have a cardiac pacemaker implant or other medical electric device. Radio waves may affect pacemaker or medical device operation, possibly resulting in serious injury. Follow the instruction for your medical device when using any wireless functionality.*
- *Always turn off wireless functionality if the computer is near automatic control equipment or appliances such as automatic doors or fire detectors. Radio waves can cause malfunction of such equipment, possibly resulting in serious injury.*
- *It may not be possible to make a network connection to a specified network name using the ad hoc network function. If this occurs, the new network (*) will have to be configured for all computers connected to the same network in order to re-enable network connections.
* Please be sure to use new network name.*

Security

- TOSHIBA strongly recommend that you enable encryption functionality, otherwise your computer will be open to illegal access by an outsider using a wireless connection. If this occurs, the outsider may illegally access your system, eavesdrop, or cause the loss or destruction of stored data.
- TOSHIBA is not liable for the loss of data due to eavesdropping or illegal access through the wireless LAN and the damage thereof.

Card Specifications

Compatibility	■ IEEE 802.11 Standard for Wireless LANs
Network Operating System	■ Microsoft Windows Networking
Media Access Protocol	■ CSMA/CA (Collision Avoidance) with Acknowledgment (ACK)

Radio Characteristics

Radio Characteristics of Wireless LAN module may vary according to:

- Country/region where the product was purchased
- Type of product

Wireless communication is often subject to local radio regulations. Although Wireless LAN wireless networking products have been designed for operation in the license-free 2.4GHz band, local radio regulations may impose a number of limitations to the use of wireless communication equipment.

Radio Frequency ■ Band 2.4GHz (2400-2483.5 MHz) (Revision b/g and n)

The range of the wireless signal is related to the transmit rate of the wireless communication. Communications at lower transmit range may travel larger distances.

- The range of your wireless devices can be affected when the antennas are placed near metal surfaces and solid high-density materials.
- Range is also impacted due to "obstacles" in the signal path of the radio that may either absorb or reflect the radio signal.

Bluetooth wireless technology

Some computers in this series have Bluetooth wireless communication function which eliminates the need for cables between electronic devices such as computers, printers and mobile phones. When it is enabled, Bluetooth provides the wireless personal area network environment which is safe and trustworthy, that is quick and easy.

You cannot use the computer's built-in Bluetooth functions and an external Bluetooth adaptor simultaneously. For reference, Bluetooth wireless technology has the following features:

Security

Two advanced security mechanisms ensure a high level of security:

- Authentication prevents access to critical data and makes it impossible to falsify the origin of a message.
- Encryption prevents eavesdropping and maintains link privacy.

Worldwide operation

The Bluetooth radio transmitter and receiver operate in the 2.4GHz band, which is license-free and compatible with radio systems in most countries in the world.

Radio links

You can easily establish links between two or more devices, with these links being maintained even if the devices are not within a line-of-sight of each other.

Radio Regulatory Information

The Wireless device must be installed and used in strict accordance with the manufacturer's instructions as described in the user documentation that comes with the product. This product complies with the following radio frequency and safety standards.

Europe

Restrictions for Use of 2400.0-2483.5MHz Frequencies in Europe

France:	Outdoor use limited to 10mW e.i.r.p. within the band 2454-2483.5MHz	Military Radiolocation use.Refarming of the 2.4GHz band has been ongoing in recent years to allow current relaxed regulation Full implementation planned 2012.
Italy:	-	For private use, a general authorization is required if WAS/ RLAN's are used outside own premises. For public use, a general authorization is required.
Luxembourg:	Implemented	General authorization required for network and service supply.
Norway:	Implemented	This subsection does not apply for the geographical area within a radius of 20 km from the centre of Ny-Alesund.
Russian Federation:	-	Only for indoor applications.

To remain in conformance with European spectrum usage laws for Wireless LAN operation, the above 2.4GHz channel limitations apply for outdoor usage. The user should use the wireless LAN utility to check the current channel of operation. If operation is occurring outside of the allowable frequencies for outdoor use, as listed above, the user must contact the applicable national spectrum regulator to request a license for outdoor operation.

Canada - Industry Canada (IC)

This device complies with RSS-210 of the Industry Canada Rules. Operation is subject to the following two conditions: (1) This device may not cause harmful interference, and (2) this device must accept any interference received, including interference that may cause undesired operation.

Ce dispositif est conforme à la norme CNR-210 d'Industrie Canada applicable aux appareils radio exempts de licence. Son fonctionnement est sujet aux deux conditions suivantes: (1) le dispositif ne doit pas produire de brouillage préjudiciable, et (2) ce dispositif doit accepter tout brouillage reçu, y compris un brouillage susceptible de provoquer un fonctionnement indésirable.

The term "IC" before the equipment certification number only signifies that the Industry Canada technical specifications were met.

Radiation Exposure Statement (IC)

The product complies with the Canada portable RF exposure limit set forth for an uncontrolled environment and is safe for intended operation as described in this manual. The further RF exposure reduction can be achieved if the product can be kept as far as possible from the user body or set the device to lower output power if such function is available.

Déclaration d'exposition aux radiations (IC)

Le produit est conforme aux limites d'exposition pour les appareils portables RF pour les États-Unis et le Canada établies pour un environnement non contrôlé. Le produit est sûr pour un fonctionnement tel que décrit dans ce manuel. La réduction aux expositions RF peut être augmentée si l'appareil peut être conservé aussi loin que possible du corps de l'utilisateur ou que le dispositif est réglé sur la puissance de sortie la plus faible si une telle fonction est disponible.

USA-Federal Communications Commission (FCC)

This equipment has been tested and found to comply with the limits for a Class B digital device, pursuant to Part 15 of FCC Rules. These limits are designed to provide reasonable protection against harmful interference in a residential installation.

Refer to the FCC information section for the detailed information.

Radiation Exposure Statement (FCC)

The product complies with the FCC portable RF exposure limit set forth for an uncontrolled environment and is safe for intended operation as described in this manual. The further RF exposure reduction can be achieved if the product can be kept as far as possible from the user body or set the device to lower output power if such function is available.

Taiwan

Article 12

Without permission granted by the NCC, any company, enterprise, or user is not allowed to change frequency, enhance transmitting power or alter original characteristics as well as performance to an approved low power radio frequency device.

Article 14

The low power radio-frequency devices shall not influence aircraft security and interfere legal communications;

If found, the user shall cease operating immediately until no interference is achieved.

The said legal communications means radio communications is operated in compliance with the Telecommunications Act.

The low power radio-frequency devices must be susceptible with the interference from legal communications or ISM radio wave radiated devices.

Using this equipment in Japan

In Japan, the frequency bandwidth of 2,400MHz to 2,483.5MHz for second generation low-power data communication systems such as this equipment overlaps that of mobile object identification systems (premises radio station and specified low-power radio station).

1. Important notice

The frequency bandwidth of this equipment may operate within the same range as industrial devices, scientific devices, medical devices, microwave ovens, licensed radio stations and non-licensed specified low-power radio stations for mobile object identification systems (RFID) used in factory production lines (Other Radio Stations).

1. Before using this equipment, ensure that it does not interfere with any of the equipment listed above.
2. If this equipment causes RF interference to other radio stations, promptly change the frequency being used, change the location of use, or turn off the source of emissions.
3. Contact an authorized TOSHIBA service provider if you have problems with interference caused by this product to Other Radio Stations.

2. Indication for Wireless LAN

The indication shown below appears on this equipment.

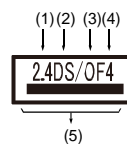

1. 2.4 : This equipment uses a frequency of 2.4GHz.
2. DS : This equipment uses DS-SS modulation.
3. OF : This equipment uses OFDM modulation.
4. 4 : The interference range of this equipment is less than 40m.
5.  : This equipment uses a frequency bandwidth from 2,400MHz to 2,483.5MHz. It is possible to avoid the band of mobile object identification systems.

3. Indication for Bluetooth

The indication shown below appears on this equipment.

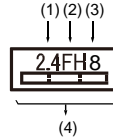

1. 2.4 : This equipment uses a frequency of 2.4 GHz.
2. FH : This equipment uses FH-SS modulation.
3. 1 : The interference range of this equipment is less than 10m.
4.  : This equipment uses a frequency bandwidth from 2,400 MHz to 2,483.5 MHz. It is impossible to avoid the band of mobile object identification systems.

Device Authorization

This device obtains the Technical Regulation Conformity Certification and it belongs to the device class of radio equipment of low-power data communication system radio station stipulated in the Telecommunications Business Law of Japan.

- Realtek® RTL8723BS 802.11n Wireless LAN and Bluetooth

The Name of the radio equipment: RTL8723BS

DSP Research, Inc.

Approval Number: D140063003

The following restrictions apply:

- Do not disassemble or modify the device.
- Do not install the embedded wireless module into other device.

Radio approvals for wireless devices

This equipment is approved to the radio standard by the countries/regions in the following table.



If you use this equipment in the countries/regions which are not listed in the table blow, please contact TOSHIBA Support.

As of May 2014

Austria	Belgium	Bulgaria	Canada
Cyprus	Czech Rep	Denmark	Estonia
Finland	France	Germany	Greece
Hong Kong	Hungary	Iceland	India
Indonesia	Ireland	Italy	Japan
Korea	Latvia	Liechtenstein	Lithuania
Luxemburg	Malta	Monaco	Netherlands
Norway	Philippines	Poland	Portugal
Romania	Slovak Republic	Slovenia	Spain
Sweden	Switzerland	UK	USA

Legal Footnotes

Non-applicable Icons

Certain computer chassis are designed to accommodate all possible configurations for an entire product series. Therefore, please be aware that your selected model may not have all the features and specifications corresponding to all of the icons or switches shown on the computer chassis.

CPU

Central Processing Unit (CPU) Performance Legal Footnotes.

CPU performance in your computer product may vary from specifications under the following conditions:

- use of certain external peripheral products
- use of battery power instead of AC power
- use of certain multimedia, computer generated graphics or video applications
- use of standard telephone lines or low speed network connections
- use of complex modeling software, such as high end computer aided design applications
- use of several applications or functionalities simultaneously
- use of computer in areas with low air pressure (high altitude >1,000 meters or >3,280 feet above sea level)
- use of computer at temperatures outside the range of 5°C to 30°C (41°F to 86°F) or >25°C (77°F) at high altitude (all temperature references are approximate and may vary depending on the specific computer model - contact TOSHIBA support for details).

CPU performance may also vary from specifications due to design configuration.

Under some conditions, your computer product may automatically shut-down. This is a normal protective feature designed to reduce the risk of lost data or damage to the product when used outside recommended conditions. To avoid risk of lost data, always make back-up copies of data by periodically storing it on an external storage medium. For optimum performance, use your computer product only under recommended conditions. Read additional restrictions in your product documentation. Contact TOSHIBA technical service and support, refer to [TOSHIBA support](#) section for more information.

Memory (Main System)

Part of the main system memory may be used by the graphics system for graphics performance and therefore reduce the amount of main system memory available for other computing activities. The amount of main system memory allocated to support graphics may vary depending on the graphics system, applications utilized, system memory size and other factors.

Battery Life

Battery life may vary considerably depending on product model, configuration, applications, power management settings and features utilized, as well as the natural performance variations produced by the design of individual components. Published battery life numbers are achieved on select models and configurations tested by TOSHIBA at the time of publication. Recharge time varies depending on usage. Battery may not charge while computer is consuming full power.

After going through many charge and discharge cycles, the battery will lose its ability to perform at maximum capacity and will need to be replaced. This is a normal phenomenon for all batteries. To purchase a new battery pack, see the accessories information that is shipped with your computer.

LCD

Over a period of time, and depending on the usage of the computer, the brightness of the LCD screen will deteriorate. This is an intrinsic characteristic of LCD technology.

Maximum brightness is only available when operating in AC power mode. Screen will dim when the computer is operated on battery power and you may not be able to increase the brightness of the screen.

Graphics Processing Unit (GPU)

Graphics processing unit (GPU) performance may vary depending on product model, design configuration, applications, power management settings and features utilized. GPU performance is only optimized when

operating in AC power mode and may decrease considerably when operating in battery power mode.

Total Available Graphics Memory is the total of, as applicable, Dedicated Video Memory, System Video Memory and Shared System Memory. Shared System Memory will vary depending on system memory size and other factors.

Wireless LAN

The transmission speed over the wireless LAN and the distance over which wireless LAN can reach may vary depending on surrounding electromagnetic environment, obstacles, access point design and configuration, and client design and software/hardware configurations.

The actual transmission speed will be lower than the theoretical maximum speed.

Copy Protection

Applicable copy protection standards included in certain media may prevent or limit recording or viewing of the media.

Glossary

The terms in this glossary cover topics related to this manual. Alternate naming is included for reference.

Abbreviations

AC:	Alternating Current
AMT:	Intel Active Management Technology
ASCII:	American Standard Code for Information Interchange
BIOS:	Basic Input/output System
BD-ROM:	Blu-ray Disc Read-only Memory
bps:	bits per second
CD:	Compact Disc
CD-ROM:	Compact Disc Read-only Memory
CD-RW:	Compact Disc-rewritable
CMOS:	Complementary Metal-oxide Semiconductor
CPU:	Central Processing Unit
DC:	Direct Current
DDR:	Double Data Rate
DIMM:	Dual Inline Memory Module
DVD:	Digital Versatile Disc

DVD-R:	Digital Versatile Disc-recordable
DVD-RAM:	Digital Versatile Disc-random Access Memory
DVD-R DL:	Digital Versatile Disc Recordable Dual Layer
DVD-ROM:	Digital Versatile Disc-read Only Memory
DVD-RW:	Digital Versatile Disc-rewritable
DVD+R DL:	Digital Versatile Disc Recordable Double Layer
FAT:	File Allocation Table
FCC:	Federal Communications Commission
FHD:	Full High Definition
GB:	gigabyte
GBps:	gigabytes per second
HD:	High Definition
HD+:	High Definition Plus
HDD:	Hard Disk Drive
HDMI:	High-definition Multimedia Interface
HDMI CEC:	High-definition Multimedia Interface Consumer Electronics Control
HTML:	Hypertext Markup Language
IEEE:	Institute of Electrical and Electronics Engineers
I/O:	Input/Output
IRQ:	interrupt request
ISP:	Internet Service Provider
KB:	kilobyte
LAN:	Local Area Network
LCD:	Liquid Crystal Display
LED:	Light Emitting Diode
MB:	megabyte
MBps:	megabytes per second
MMC:	Multi Media Card
OCR:	Optical Character Recognition (Reader)
PC:	Personal Computer
PCI:	Peripheral Component Interconnect
PCMCIA:	Personal Computer Memory Card International Association
RAM:	Random Access Memory

RGB:	Red, Green, and Blue
RFI:	Radio Frequency Interference
ROM:	Read Only Memory
RTC:	Real Time Clock
S/P DIF:	Sony/philips Digital Interface Format
SD:	Secure Digital
SDHC:	Secure Digital High Capacity
SDXC:	Secure Digital Extended Capacity
SDRAM:	Synchronous Dynamic Random Access Memory
SSD:	Solid State Drive
TFT:	Thin-film Transistor
URL:	Uniform Resource Locator
USB:	Universal Serial Bus
WAN:	Wide Area Network
WQHD:	Wide Quad High Definition
www:	World Wide Web

Index

A

AC adaptor
additional 4-14
connecting 2-3

B

Battery
extending life 4-6
monitoring capacity 4-5
save mode 5-3

Bluetooth 7-6

C

Cleaning the computer 1-16

Cooling vents 3-7

D

Display
automatic power off 5-2
screen 3-2, 3-5

Documentation list 2-1

E

Equipment checklist 2-1

External monitor
problems 6-8

G

Graphics Processing Unit 3-8

H

HDMI out port 3-4

M

Media care
Card care 4-8

memory media card
inserting 4-8
removing 4-9

Memory media slot 4-7

Moving the computer 1-16

MultiMediaCard
removing 4-9

P

Password
power on 5-3

Power
Hibernation Mode 2-10
Shut Down mode 2-8
Sleep Mode 2-9
turning off 2-8
turning on 2-5

Problems
Analyzing the problem 6-2
Battery 6-5

External monitor 6-8
Hardware and system
checklist 6-4
Internal display panel 6-6
Memory Media Card 6-6
Overheating power
down 6-4
Power 6-4
Real Time Clock 6-6
Sound system 6-7
TOSHIBA support 6-9
USB device 6-7

V

Video mode 4-14
Video RAM 3-8

W

Web Camera 3-3, 3-5
Wireless communication 7-4

R

Recovery hard disk drive 5-6
Recovery Media 5-5
Restarting the computer 2-9

S

SD/SDHC/SDXC Card
formatting 4-8
note 4-7

Sleep Mode
setting 2-9

Sound system
problems 6-7

T

TOSHIBA Desktop Assist 5-1
Touch Screen

U

USB device
problems 6-7