

# FCC TEST REPORT

**REPORT NO.:** RF970502A05

**MODEL NO.:** KR-0817

**RECEIVED:** May 2, 2008

**TESTED:** May 5 ~ 6, 2008

**ISSUED:** May 14, 2008

**APPLICANT:** Chicony Electronics Co., Ltd.

**ADDRESS:** No. 25, Wu-Gong 6th Rd., Wu Ku Industrial  
Park, Taipei Hsien, Taiwan, R.O.C.

**ISSUED BY:** Advance Data Technology Corporation

**LAB ADDRESS:** No. 47, 14th Ling, Chia Pau Tsuen, Lin Kou Hsiang  
244, Taipei Hsien, Taiwan, R.O.C.

This test report consists of 18 pages in total. It may be duplicated completely for legal use with the approval of the applicant. It should not be reproduced except in full, without the written approval of our laboratory. The client should not use it to claim product endorsement by TAF, A2LA or any government agencies. The test results in the report only apply to the tested sample.



## Table of Contents

1	CERTIFICATION .....	3
2	SUMMARY OF TEST RESULTS .....	4
2.1	MEASUREMENT UNCERTAINTY .....	4
3	GENERAL INFORMATION .....	5
3.1	GENERAL DESCRIPTION OF EUT .....	5
3.1	DESCRIPTION OF TEST MODES .....	6
3.2	CONFIGURATION OF SYSTEM UNDER TEST .....	6
3.2.1	TEST MODE APPLICABILITY AND TESTED CHANNEL DETAIL .....	7
3.3	GENERAL DESCRIPTION OF APPLIED STANDARDS .....	7
3.4	DESCRIPTION OF SUPPORT UNITS .....	7
4	TEST PROCEDURE AND RESULT .....	8
4.1	CONDUCTED EMISSION MEASUREMENT .....	8
4.2	RADIATED EMISSION MEASUREMENT .....	8
4.2.1	LIMITS OF RADIATED EMISSION MEASUREMENT .....	8
4.2.2	TEST INSTRUMENT .....	9
4.2.3	TEST PROCEDURE .....	10
4.2.4	TEST SETUP .....	11
4.2.5	EUT OPERATING CONDITION .....	11
4.2.6	TEST RESULT .....	12
5	PHOTOGRAPHS OF THE TEST CONFIGURATION .....	16
6	INFORMATION ON THE TESTING LABORATORIES .....	17
7	APPENDIX A – MODIFICATIONS RECORDERS FOR ENGINEERING CHANGES TO THE EUT BY THE LAB .....	18



# 1 CERTIFICATION

**PRODUCT:** Wireless Keyboard  
**BRAND NAME:** Gateway  
**MODEL NO.:** KR-0817  
**APPLICANT:** Chicony Electronics Co., Ltd.  
**TEST SAMPLE:** ENGINEERING SAMPLE  
**TESTED:** May 5 ~ 6, 2008  
**STANDARDS:** FCC Part 15, Subpart C (Section 15.227)  
ANSI C63.4 -2003  
RSS-310 Issued 1 (September 2005)  
RSS-Gen Issued 1 (September 2005)

The above equipment has been tested by **Advance Data Technology Corporation**, and found compliance with the requirement of the above standards. The test record, data evaluation & Equipment Under Test (EUT) configurations represented herein are true and accurate accounts of the measurements of the sample's EMC characteristics under the conditions specified in this report.

**PREPARED BY :** Annie Chang , **DATE:** May 14, 2008  
( Annie Chang / Senior Specialist )

**TECHNICAL ACCEPTANCE :** Jamison Chan , **DATE:** May 14, 2008  
Responsible for RF ( Jamison Chan / Supervisor )

**APPROVED BY :** Ken Liu , **DATE:** May 14, 2008  
( Ken Liu / Deputy Manager )

## 2 SUMMARY OF TEST RESULTS

The EUT has been tested according to the following specifications:

APPLIED STANDARD: FCC Part 15, Subpart C			
STANDARD PARAGRAPH	TEST TYPE	RESULT	REMARK
15.207	Conducted Emission Test	N/A	Power supply is 3Vdc from batteries
15.227 15.209	Radiated Emission Test	PASS	Minimum passing margin is -16.75dB at 953.347MHz

### 2.1 MEASUREMENT UNCERTAINTY

Where relevant, the following measurement uncertainty levels have been estimated for tests performed on the EUT as specified in CISPR 16-4-2:

This uncertainty represents an expanded uncertainty expressed at approximately the 95% confidence level using a coverage factor of  $k=2$ .

Measurement	Uncertainty
Radiated emissions	3.72 dB

### 3 GENERAL INFORMATION

#### 3.1 GENERAL DESCRIPTION OF EUT

<b>PRODUCT</b>	Wireless Keyboard
<b>MODEL NO.</b>	KR-0817
<b>FCC ID</b>	E8HKR-0817
<b>POWER SUPPLY</b>	3.0Vdc from batteries
<b>MODULATION TYPE</b>	FSK
<b>CARRIER FREQUENCY OF EACH CHANNEL</b>	27.145 MHz, 27.195 MHz
<b>NUMBER OF CHANNEL</b>	2
<b>ANTENNA TYPE</b>	Loop antenna
<b>DATA CABLE</b>	NA
<b>I/O PORTS</b>	NA
<b>ASSOCIATED DEVICES</b>	NA

**NOTE:**

1. The EUT is a wireless keyboard, which is a transmitter.
2. The above EUT information was declared by manufacturer and for more detailed features description, please refer to the manufacturer's specifications or User's Manual.

### 3.1 DESCRIPTION OF TEST MODES

2 channels were provided to this EUT

Channel	Frequency (MHz)
1	27.145MHz
2	27.195MHz

### 3.2 CONFIGURATION OF SYSTEM UNDER TEST

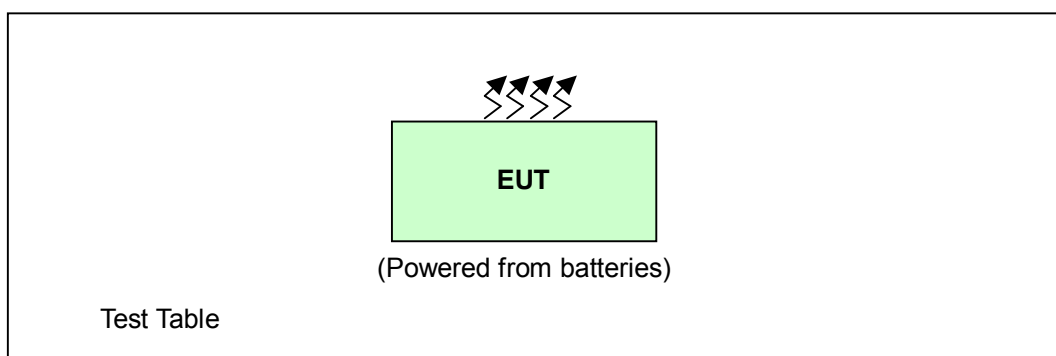

### 3.2.1 TEST MODE APPLICABILITY AND TESTED CHANNEL DETAIL

EUT configure mode	Applicable to		Description
	PLC	RE<1G	
-	Note	√	N/A

Where PLC: Power Line Conducted Emission RE<1G RE: Radiated Emission below 1GHz

Note: No need to concern of Conducted Emission due to the EUT is powered by battery.

#### **Radiated Emission Test (Below 1 GHz):**

Following channel(s) was (were) selected for the final test as listed below.

OPERATING STATE	Available Channel	Tested Channel	Modulation Type
Operating	1 to 2	1, 2	FSK

### 3.3 GENERAL DESCRIPTION OF APPLIED STANDARDS

The EUT is a RF product. According to the specifications of the manufacturer, it must comply with the requirements of the following standards:

**FCC Part 15, Subpart C. (15.227)**  
**ANSI C63.4 –2003**  
**RSS-310 Issued 1 (September 2005)**  
**RSS-Gen Issued 1 (September 2005)**

All test items have been performed and recorded as per the above standards.

### 3.4 DESCRIPTION OF SUPPORT UNITS

The EUT has been tested as an independent unit.

## 4 TEST PROCEDURE AND RESULT

### 4.1 CONDUCTED EMISSION MEASUREMENT

NA

### 4.2 RADIATED EMISSION MEASUREMENT

#### 4.2.1 LIMITS OF RADIATED EMISSION MEASUREMENT

According to 15.227 the field strength of Emissions from intentional radiators operated under these frequencies bands shall not exceed the following:

Fundamental Frequency (MHz)	Field Strength of Fundamental (dBuV/m)	
	Peak	Average
26.96-27.28	100	80

Field strength limits are at the distance of 3 meters, Emissions radiated outside of the specified bands, shall be according to the general radiated limits in 15.209 as following:

Frequencies (MHz)	Field strength (microvolts/meter)	Measurement distance (meters)
0.009-0.490	2400/F(kHz)	300
0.490-1.705	24000/F(kHz)	30
1.705-30.0	30	30
30-88	100	3
88-216	150	3
216-960	200	3
Above 960	500	3

As shown in 15.35(b), for frequencies above 1000MHz, the field strength limits are based on average detector, however, the peak field strength of any emission shall not exceed the maximum permitted average limits, specified above by more than 20dB under any condition of modulation.



## 4.2.2 TEST INSTRUMENT

DESCRIPTION & MANUFACTURER	MODEL NO.	SERIAL NO.	CALIBRATED UNTIL
HP Preamplifier	8447D	2432A03504	May 09, 2008
HP Preamplifier	8449B	3008A01201	Oct. 01, 2008
HP Preamplifier	8449B	3008A01292	Aug. 05, 2008
ROHDE & SCHWARZ TEST RECEIVER	ESI7	836697/012	Dec. 05, 2008
Schwarzbeck Antenna	VULB 9168	137	May 01, 2009
Schwarzbeck Antenna	VHBA 9123	480	Apr. 22, 2009
ADT. Turn Table	TT100	0306	NA
ADT. Tower	AT100	0306	NA
Software	ADT_Radiated_V 7.6.15	NA	NA
SUHNER RF cable	SF104-26.5	CABLE-CH6-17m-01	Nov. 04, 2008
ROHDE & SCHWARZ Spectrum Analyzer	FSP 40	100035	Mar. 25, 2009
Loop Antenna R & S	HFH2-Z2	100070	Jan. 13, 2009

- NOTE:**
1. The calibration interval of the above test instruments is 12 months. And the calibrations are traceable to NML/ROC and NIST/USA.
  2. The horn antenna and HP preamplifier (model: 8449B) are used only for the measurement of emission frequency above 1GHz if tested.
  3. The test was performed in ADT Chamber No. 6.
  4. The Industry Canada Reference No. IC 3789-6.

### 4.2.3 TEST PROCEDURE

- a. The EUT was placed on the top of a rotating table 0.8 meters above the ground at a 3 meter semi-anechoic chamber. The table was rotated 360 degrees to determine the position of the highest radiation.
- b. The EUT was set 3 meters away from the interference-receiving antenna, which was mounted on the top of a variable-height antenna tower.
- c. The antenna's height is varied from one meter to four meters above the ground to determine the maximum value of the field strength. Both horizontal and vertical polarizations of the antenna are set to make the measurement.
- d. For each suspected emission, the EUT was arranged to its worst case and then the antenna was tuned to heights from 1 meter to 4 meters and the rotatable table was turned from 0 degrees to 360 degrees to find the maximum reading.
- e. The test-receiver system was set to Peak Detect Function and Specified Bandwidth with Maximum Hold Mode.
- f. If the emission level of the EUT in peak mode was lower than the limit specified, then testing could be stopped and the peak values of the EUT would be reported. Otherwise the emissions would be re-tested one by one using peak, quasi-peak method or average method as specified and then reported in data sheet.

**NOTE:**

1. The resolution bandwidth and video bandwidth of test receiver/spectrum analyzer is 120kHz for Quasi-peak detection at frequency below 1GHz.
2. The resolution bandwidth and video bandwidth of test receiver/spectrum analyzer is 1 MHz for Peak detection (PK) at frequency above 1GHz.

#### 4.2.4 TEST SETUP

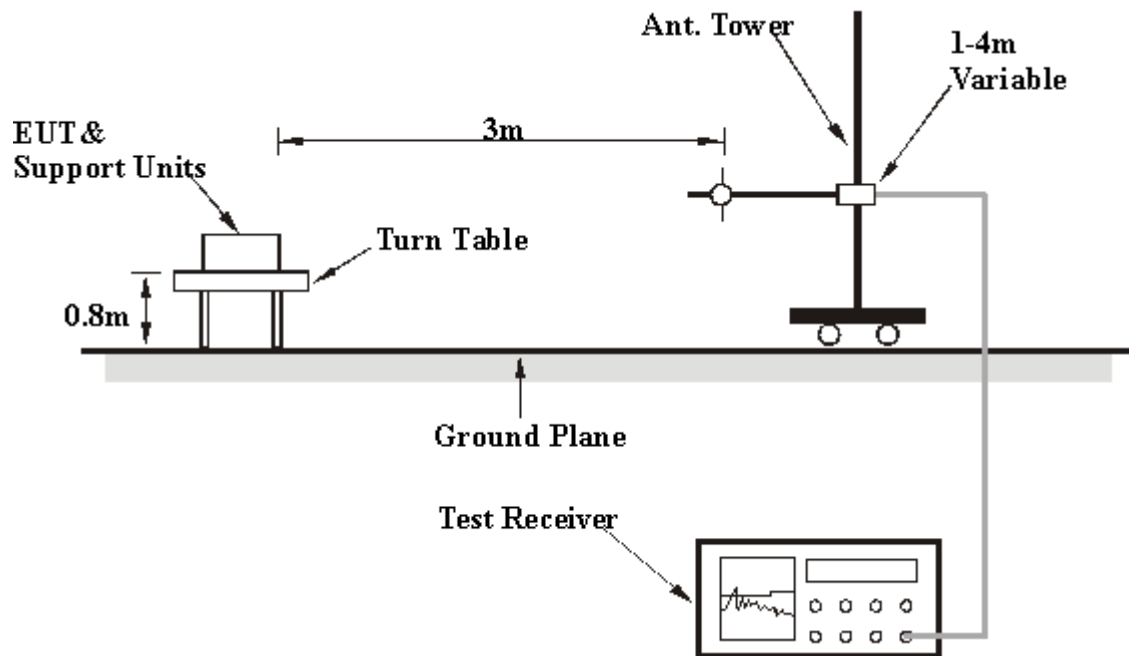

For the actual test configuration, please refer to the related item in this test report - Photographs of the Test Configuration.

#### 4.2.5 EUT OPERATING CONDITION

Set the EUT under transmission condition continuously at specific channel frequency.

## 4.2.6 TEST RESULT

<b>MODULATION TYPE</b>	FSK	<b>CHANNEL</b>	1
<b>INPUT POWER</b>	3Vdc	<b>FREQUENCY RANGE</b>	Below 1000MHz
<b>ENVIRONMENTAL CONDITIONS</b>	23deg. C, 80% RH, 1001hPa	<b>DETECTOR FUNCTION</b>	Peak / Average
<b>TESTED BY</b>	Jun Wu	<b>OPERATING STATE</b>	Operating

TEST DISTANCE: 3 M								
No.	Freq. (MHz)	Emission Level (dBuV/m)	Limit (dBuV/m)	Margin (dB)	Antenna Height (m)	Table Angle (Degree)	Raw Value (dBuV)	Correction Factor (dB/m)
1	*27.145	53.78PK	100.00	-66.22	1.86	331	33.56	20.22
2	*27.145	36.17AV	80.00	-43.83	1.86	331	15.95	20.22

### REMARKS:

- 1 Emission level(dBuV/m)=Raw Value(dBuV) + Correction Factor(dB/m)
- 2 Correction Factor(dB/m) = Antenna Factor (dB/m) + Cable Factor (dB)
- 3 The other emission levels were very low against the limit.
- 4 Margin value = Emission level – Limit value.
- 5 "\*"= Fundamental frequency.
- 6 Loop antenna was used for all radiated emission below 30MHz.

<b>MODULATION TYPE</b>	FSK	<b>CHANNEL</b>	1
<b>INPUT POWER</b>	3Vdc	<b>FREQUENCY RANGE</b>	Below 1000MHz
<b>ENVIRONMENTAL CONDITIONS</b>	23deg. C, 80% RH, 1001hPa	<b>DETECTOR FUNCTION</b>	Quasi-Peak
<b>TESTED BY</b>	Jun Wu	<b>OPERATING STATE</b>	Operating

#### ANTENNA POLARITY & TEST DISTANCE: HORIZONTAL AT 3 M

No.	Freq. (MHz)	Emission Level (dBuV/m)	Limit (dBuV/m)	Margin (dB)	Antenna Height (m)	Table Angle (Degree)	Raw Value (dBuV)	Correction Factor (dB/m)
1	222.445	27.20 QP	46.00	-18.80	1.42 H	4	13.88	13.32
2	803.667	27.01 QP	46.00	-18.99	1.26 H	145	-2.13	29.14
3	842.545	27.43 QP	46.00	-18.57	1.14 H	136	-2.18	29.61
4	863.928	28.04 QP	46.00	-17.96	1.10 H	124	-1.78	29.82
5	885.311	27.95 QP	46.00	-18.05	1.08 H	10	-2.05	30.00
6	916.413	28.12 QP	46.00	-17.88	1.03 H	106	-2.03	30.15

#### ANTENNA POLARITY & TEST DISTANCE: VERTICAL AT 3 M

No.	Freq. (MHz)	Emission Level (dBuV/m)	Limit (dBuV/m)	Margin (dB)	Antenna Height (m)	Table Angle (Degree)	Raw Value (dBuV)	Correction Factor (dB/m)
1	103.868	26.15 QP	43.50	-17.35	1.00 V	193	14.58	11.57
2	807.555	27.67 QP	46.00	-18.33	1.08 V	268	-1.52	29.19
3	844.489	27.59 QP	46.00	-18.41	1.16 V	121	-2.04	29.63
4	865.872	28.18 QP	46.00	-17.82	1.18 V	139	-1.66	29.84
5	893.086	28.08 QP	46.00	-17.92	1.24 V	271	-1.99	30.07
6	931.964	27.70 QP	46.00	-18.30	1.30 V	358	-2.47	30.17
7	957.234	28.31 QP	46.00	-17.69	1.39 V	217	-1.99	30.30

- REMARKS:**
1. Emission level(dBuV/m)=Raw Value(dBuV) + Correction Factor(dB/m)
  2. Correction Factor(dB/m) = Antenna Factor (dB/m) + Cable Factor (dB)
  3. The other emission levels were very low against the limit.
  4. Margin value = Emission level – Limit value.

<b>MODULATION TYPE</b>	FSK	<b>CHANNEL</b>	2
<b>INPUT POWER</b>	3Vdc	<b>FREQUENCY RANGE</b>	Below 1000MHz
<b>ENVIRONMENTAL CONDITIONS</b>	23deg. C, 80% RH, 1001hPa	<b>DETECTOR FUNCTION</b>	Peak / Average
<b>TESTED BY</b>	Jun Wu	<b>OPERATING STATE</b>	Operating

<b>TEST DISTANCE: 3 M</b>								
No.	Freq. (MHz)	Emission Level (dBuV/m)	Limit (dBuV/m)	Margin (dB)	Antenna Height (m)	Table Angle (Degree)	Raw Value (dBuV)	Correction Factor (dB/m)
1	*27.195	54.35PK	100.00	-65.65	1.96	351	34.13	20.22
2	*27.195	37.10AV	80.00	-42.90	1.96	351	16.88	20.22

**REMARKS:**

1. Emission level(dBuV/m)=Raw Value(dBuV) + Correction Factor(dB/m)
2. Correction Factor(dB/m) = Antenna Factor (dB/m) + Cable Factor (dB)
3. The other emission levels were very low against the limit.
4. Margin value = Emission level – Limit value.
5. "\*" = Fundamental frequency.
6. Loop antenna was used for all radiated emission below 30MHz.

<b>MODULATION TYPE</b>	FSK	<b>CHANNEL</b>	2
<b>INPUT POWER</b>	3Vdc	<b>FREQUENCY RANGE</b>	Below 1000MHz
<b>ENVIRONMENTAL CONDITIONS</b>	23deg. C, 80% RH, 1001hPa	<b>DETECTOR FUNCTION</b>	Quasi-Peak
<b>TESTED BY</b>	Jun Wu	<b>OPERATING STATE</b>	Operating

#### ANTENNA POLARITY & TEST DISTANCE: HORIZONTAL AT 3 M

No.	Freq. (MHz)	Emission Level (dBuV/m)	Limit (dBuV/m)	Margin (dB)	Antenna Height (m)	Table Angle (Degree)	Raw Value (dBuV)	Correction Factor (dB/m)
1	224.389	27.14 QP	46.00	-18.86	1.38 H	328	13.64	13.50
2	807.555	27.55 QP	46.00	-18.45	1.24 H	178	-1.64	29.19
3	830.882	27.23 QP	46.00	-18.77	1.18 H	211	-2.24	29.47
4	875.591	27.97 QP	46.00	-18.03	1.13 H	172	-1.95	29.92
5	883.367	27.96 QP	46.00	-18.04	1.10 H	67	-2.03	29.99
6	914.469	28.48 QP	46.00	-17.52	1.04 H	10	-1.67	30.15

#### ANTENNA POLARITY & TEST DISTANCE: VERTICAL AT 3 M

No.	Freq. (MHz)	Emission Level (dBuV/m)	Limit (dBuV/m)	Margin (dB)	Antenna Height (m)	Table Angle (Degree)	Raw Value (dBuV)	Correction Factor (dB/m)
1	119.419	26.50 QP	43.50	-17.00	1.00 V	133	13.30	13.20
2	803.667	27.10 QP	46.00	-18.90	1.07 V	10	-2.04	29.14
3	840.601	28.44 QP	46.00	-17.56	1.12 V	124	-1.15	29.59
4	865.872	27.22 QP	46.00	-18.78	1.18 V	73	-2.62	29.84
5	883.367	27.68 QP	46.00	-18.32	1.24 V	217	-2.31	29.99
6	926.132	27.58 QP	46.00	-18.42	1.26 V	241	-2.59	30.17
7	<b>953.347</b>	<b>29.25 QP</b>	<b>46.00</b>	<b>-16.75</b>	<b>1.33 V</b>	<b>187</b>	<b>-1.00</b>	<b>30.25</b>

- REMARKS:**
1. Emission level(dBuV/m)=Raw Value(dBuV) + Correction Factor(dB/m)
  2. Correction Factor(dB/m) = Antenna Factor (dB/m) + Cable Factor (dB)
  3. The other emission levels were very low against the limit.
  4. Margin value = Emission level – Limit value.

## 5 PHOTOGRAPHS OF THE TEST CONFIGURATION

Please refer to the attached file (Test Setup Photo).



## 6 INFORMATION ON THE TESTING LABORATORIES

We, ADT Corp., were founded in 1988 to provide our best service in EMC, Radio, Telecom and Safety consultation. Our laboratories are accredited and approved by the following approval agencies according to ISO/IEC 17025

<b>USA</b>	FCC, UL, A2LA
<b>Germany</b>	TUV Rheinland
<b>Japan</b>	VCCI
<b>Norway</b>	NEMKO
<b>Canada</b>	INDUSTRY CANADA , CSA
<b>R.O.C.</b>	TAF, BSMI, NCC
<b>Netherlands</b>	Telefication
<b>Singapore</b>	GOST-ASIA(MOU)
<b>Russia</b>	CERTIS(MOU)

Copies of accreditation certificates of our laboratories obtained from approval agencies can be downloaded from our web site: [www.adt.com.tw/index.5/phtml](http://www.adt.com.tw/index.5/phtml).  
If you have any comments, please feel free to contact us at the following:

**Linko EMC/RF Lab:**  
Tel: 886-2-26052180  
Fax: 886-2-26051924

**Hsin Chu EMC/RF Lab:**  
Tel: 886-3-5935343  
Fax: 886-3-5935342

**Hwa Ya EMC/RF/Safety/Telecom Lab:**  
Tel: 886-3-3183232  
Fax: 886-3-3185050

**Web Site:** [www.adt.com.tw](http://www.adt.com.tw)

The address and road map of all our labs can be found in our web site also.

## **7 APPENDIX A – MODIFICATIONS RECORDERS FOR ENGINEERING CHANGES TO THE EUT BY THE LAB**

No any modifications are made to the EUT by the lab during the test.