

A B C D E

1 2 3 4 5 6

Font: Myriad Pro 4.5pt
 (大約尺寸)
 67.4 ± 0.1
 (大約尺寸)
 3.5 ± 0.1
 (大約尺寸, 所有文字請務必置中印刷)

S/N: DS*****
 DATE CODE. (YYMMDD, 請見下表對照)
 固定碼

Year		Month				Date							
ZF	16	A1	01	B0	10	A1	01	B0	10	C0	20	D0	30
ZG	17	A2	02	B1	11	A2	02	B1	11	C1	21	D1	31
ZH	18	A3	03	B2	12	A3	03	B2	12	C2	22		
ZI	19	A4	04			A4	04	B3	13	C3	23		
ZJ	20	A5	05			A5	05	B4	14	C4	24		
ZK	21	A6	06			A6	06	B5	15	C5	25		
ZL	22	A7	07			A7	07	B6	16	C6	26		
		A8	08			A8	08	B7	17	C7	27		
		A9	09			A9	09	B8	18	C8	28		
								B9	19	C9	29		

EXP.: 20191107 → ZIB1A7
 20191215 → ZIB2B5

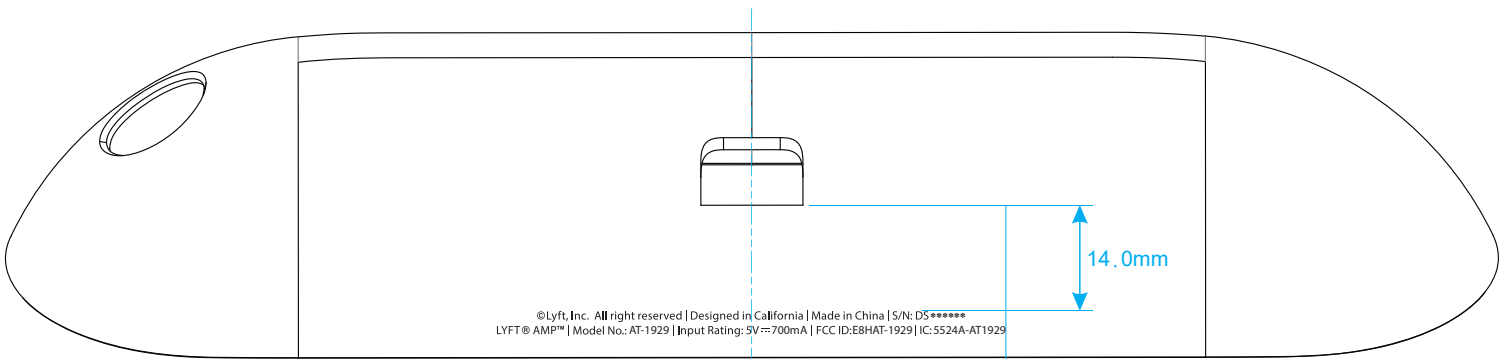

- NOTES:**
1. ALL LAYOUT LASER PRINT.
 2. NEED TO PASS CUSTOMER TO APPROVE.
 3. DRAWING FOR REFERENCE ONLY.
 4. THIS PRODUCT / COMPONENT MUST COMPLY WITH CHICONY SPECIFICATION " ISO 361

7

AT-1929			LYFT		
MODEL NO.			REMARK		
CHICONY ELECTRONICS CO.,LTD			MODEL NO.: AT-1929		
APPROVED	CHECKED	DESIGNED	SPEC: NOTES		
Tommy	T. S. Victor	Nash	FINISH: NOTES		
			TOL:	Q'TY	SIZE: A4
08/26-'19	08/26-'19	08/26-'19	SCALE: 1 : 1		UNIT: MM
			DWG NO.: 19290090L		REV: A

A B C D E