

# Chapter 4 Maintenance

## Introduction

This chapter contains periodic maintenance and performance test procedures for the PAF-19XX-EX-XXX Multi-Carrier Power Amplifier (MCPA) system.

**NOTE** Do not break seals on equipment under warranty or warranty will be null and void. Do not return equipment for warranty or repair service until factory shipping instructions are received.

## Periodic Maintenance

Periodic maintenance requirements are listed in Table 4-1, as well as the intervals at which the tasks should be performed.

Table 4-1 Periodic Maintenance

Task	Interval	Action
Inspection: Cables and Connectors	12 Months	Inspect signal and power cables for frayed insulation. Check RF connectors to be sure that they are tight
	Optional	Antenna VSWR sweep
Cleaning: Fans and Equipment	Clean as required depending on equipment operating environment	

## Troubleshooting

The following paragraphs contain a list of problems that could occur and a few suggested actions that can correct the problem. If the suggested corrective action does not eliminate the problem, please contact your Powerwave field representative or the factory for further instructions.

## Clearing Alarm Faults

Setting the MCPA front panel OFF/ON/RESET switch to RESET can clear many alarm faults. An attempt to reset the MCPA should be your first course of action. 24-Hour technical support service is available at our main phone number 888-797-9283 or 714-466-1000; select the "System Operator Technical Support" option to receive assistance from Powerwave's Applications Support Group. Refer to Table 4-2 for troubleshooting suggestions.

Table 4-2 Troubleshooting

Problem	Suggested Action
MCPA Inoperative (MCPA front panel LED red)	<ol style="list-style-type: none"> <li>1. Set MCPA OFF/ON/RESET toggle switch momentarily to RESET</li> <li>2. Check for proper power supply voltage</li> <li>3. Verify all RF connections</li> <li>4. Contact your field representative or factory</li> </ol>

## System Component Part Numbers

Table 4-3 lists the model/part numbers for ordering individual system components and manuals.

Table 4-3 System Components Part Number List

Model/Part Number	Manual Number	Description	System Maximum Quantity
G3L-830-160	-	160 Watt, 1900 MHz MCPA	12
800-09666-001	-	Subrack Fan Assembly	2 per subrack
MCR40830-1-4	-	Subrack, 4-way combined	3
800-07829-002	-	Panel, blank, MCPA	as required
FIL-19XX	-	Filter, 1900 MHz	3
800-11185-600	-	Panel, Circuit Breaker	1
1002530	-	Circuit Breaker, 50 A	12
1002529	-	Circuit Breaker, 15 A	2
700-18766-001	-	Cable, RF, 7/16 DIN-R-MA	3
700-18767-001	-	Cable, Filter, DB-15 to DB-15	3
700-18133-100	-	Cable, Filter, DC	1

## Field Replacement Procedures

The following parts and modules can be replaced in the field on site by a qualified technician with experience maintaining RF power amplifiers and similar equipment:

- MCPA
- Cooling Fans
- Subrack
- Filter
- Circuit Breaker Panel

## MCPA

To replace an MCPA module, shown in Figure 4-1, perform the steps in Table 4-3.



**CAUTION: To prevent damage to MCPA rear connector, support rear of MCPA when removing from subrack. The MCPA weight is approximately 20 lbs (9.1 kg).**

Table 4-4 MCPA Removal and Replacement Procedure

Step	Action
1.	Set MCPA front panel OFF/ON/RESET switch to OFF
2.	Rotate MCPA module quarter-turn fasteners counterclockwise
3.	With steady even pressure, use handle on front of MCPA to pull module out of enclosure as shown in Figure 4-1
4.	Replace MCPA module in reverse order of removal

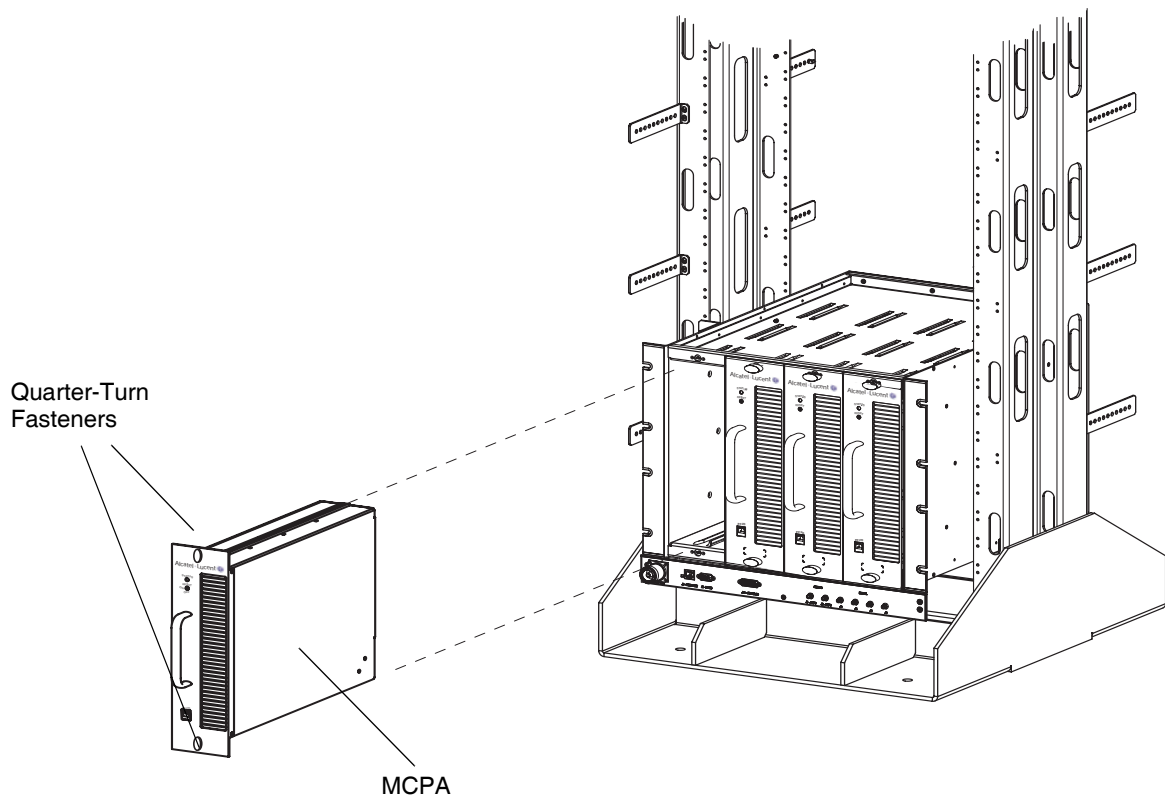

Figure 4-1 MCPA Removal and Replacement

### Subrack Cooling Fans

Refer to Chapter 3 - Air Conditioning for cooling-fan operating parameters before replacing fans. To replace an inside or rear mounted cooling fan or change the fan mounting configuration, proceed as follows:



**CAUTION: To prevent damage to MCPA rear connector, support rear of MCPA when removing from subrack. MCPA weight is approximately 20 lbs (9.1 kg).**

### Inside Mount

To replace the inside mounted fan, shown in Figure 4-2, perform the steps in Table 4-4.



**CAUTION: The replacement fan may operate when the power connector is connected. Ensure that no objects (fingers, screwdrivers, etc.) intrude into the fan area.**

Table 4-5 Inside Mount Cooling Fan Removal and Replacement Procedure

Step	Action
1.	For fan assembly located behind blank panels, rotate quarter-turn fasteners on each panel counter-clockwise to remove panels from subrack, then proceed to Step 4
2.	For fan assembly located behind MCPAs, set each front panel OFF/ON/RESET switch to OFF
3.	Read above Caution. Rotate quarter-turn fasteners on each MCPA counter-clockwise and remove MCPAs from subrack
4.	Disconnect fan power connector and pull out snap fasteners to remove fan
5.	Install replacement fan assembly in reverse order of removal

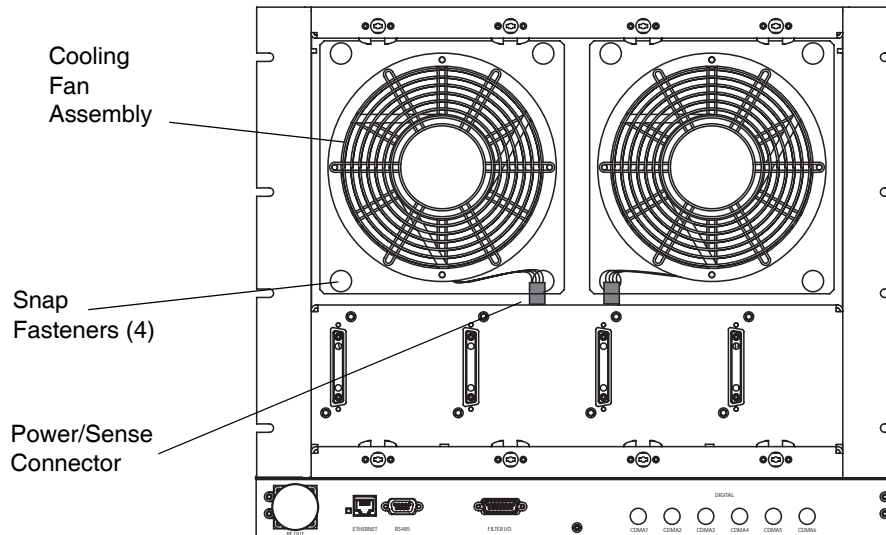

Figure 4-2 Inside Mount Cooling Fan Removal and Replacement

## Rear Mount

Rear mounted fans may be changed without shutting down the system. To replace the fans, shown in Figure 4-3, perform the steps in Table 4-5.



**CAUTION: The replacement fan may operate when the power connector is connected. Ensure that no objects (fingers, screwdrivers, etc.) intrude into the fan area.**

Table 4-6 Rear Mount Cooling Fan Removal and Replacement Procedure

Step	Action
1.	At rear of subrack, pull out snap fasteners that secure defective fan assembly to fan-mounting bracket
2.	Pull fan outward, and disconnect fan power connector
3.	See Caution. Install replacement fan assembly in reverse order of removal

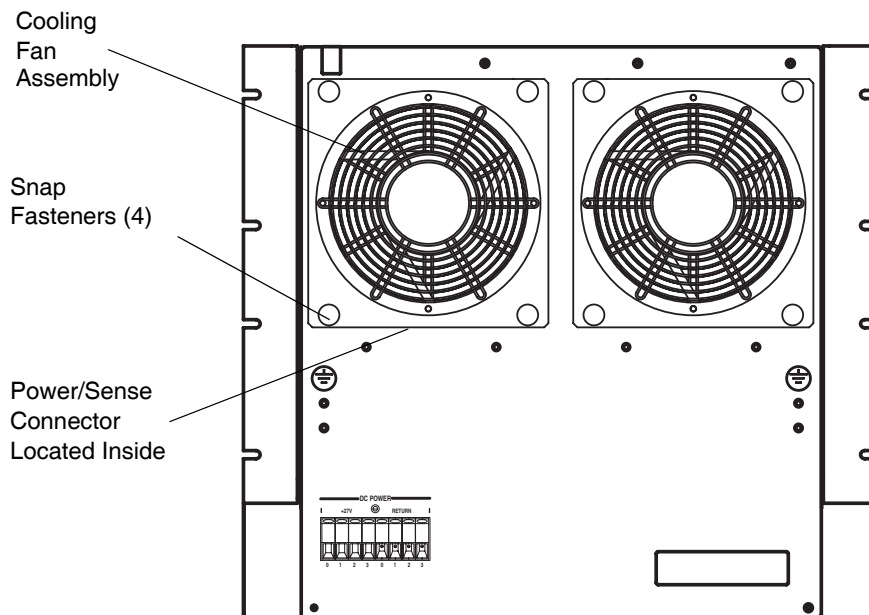

Figure 4-3 Rear Mount Cooling Fan Removal and Replacement

### Fan Inside Mount to Rear Mount Conversion

To convert the subrack fan from inside mount to rear mount, as shown in Figure 4-4, perform the steps in Table 4-6.

Table 4-7 Fan Conversion Procedure

Step	Action
1.	To remove fan assembly from subrack, follow steps listed in Table 4-5
2.	Disassemble inside mount fan assembly as shown in Figure 4-4
3.	Reassemble inside mount fan assembly into rear mount configuration shown in Figure 4-4. Maintain orientation of fan to ensure air is exhausting out rear of subrack
4.	Connect power connector, place fan assembly into mounting position, then press each snap fastener to secure fan to subrack
5.	Repeat Steps 1 through 4 for second fan

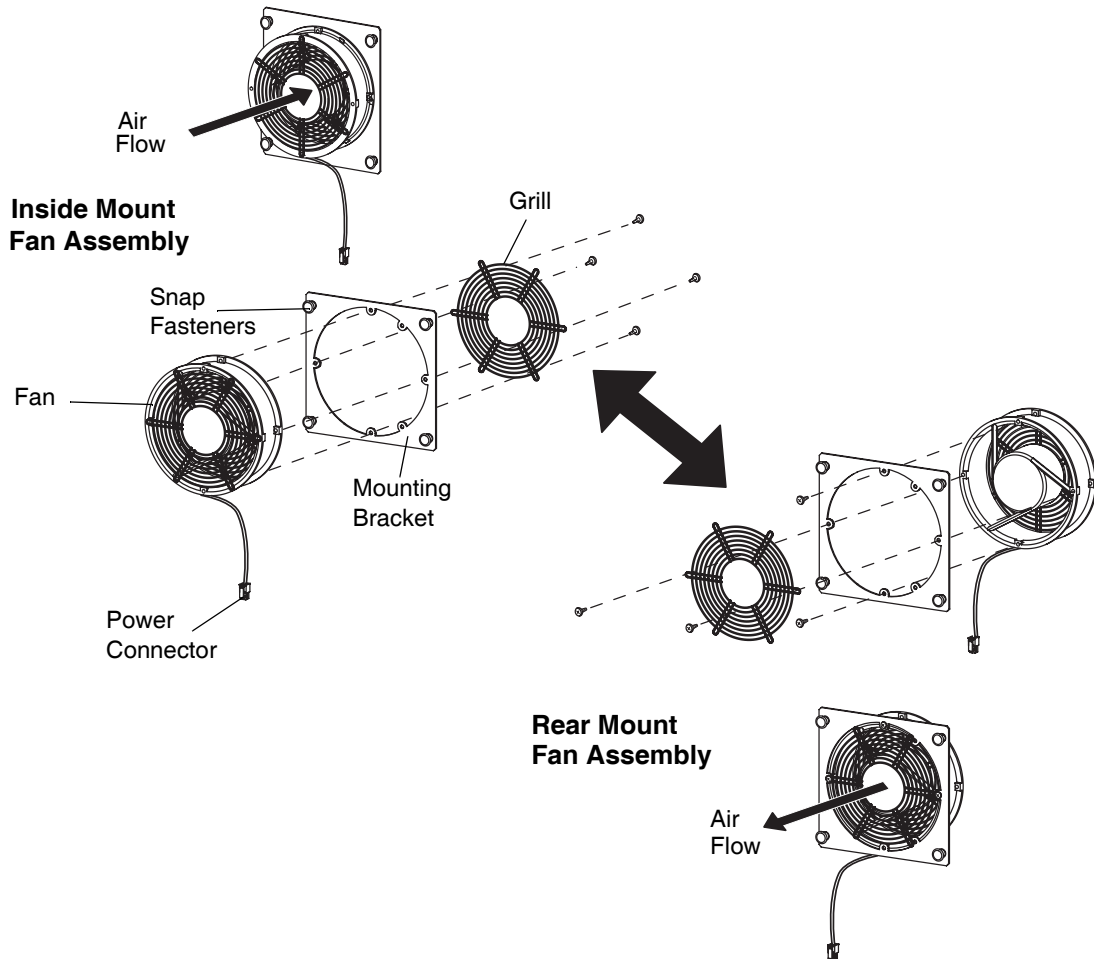

Figure 4-4 Fan Inside Mount to Rear Mount Conversion

## Subrack

To remove and replace the subrack, shown in Figure 4-5, perform the steps in Table 4-7.



**CAUTION: Support rear of Subrack when removing from rack. The subrack may disengage suddenly from the sliding brackets.**

Table 4-8 Subrack Removal and Replacement Procedure

Step	Action
1.	At affected subrack, set all MCPA OFF/ON/RESET switches to OFF
2.	At breaker panel, set all subrack associated circuit breakers to OFF
3.	Disconnect all semi-rigid RF cables between subrack and duplexer
4.	Disconnect subrack alarm cables
5.	At rear of subrack, label and disconnect all breaker panel DC power connections, maintaining DC Power cable service loop
6.	Remove four mounting screws from both sides of subrack
7.	Slide subrack forward out of frame until completely disengaged from sliding brackets. Ensure rear of subrack is supported to prevent subrack from suddenly disengaging
8.	Install new subrack in reverse order of removal

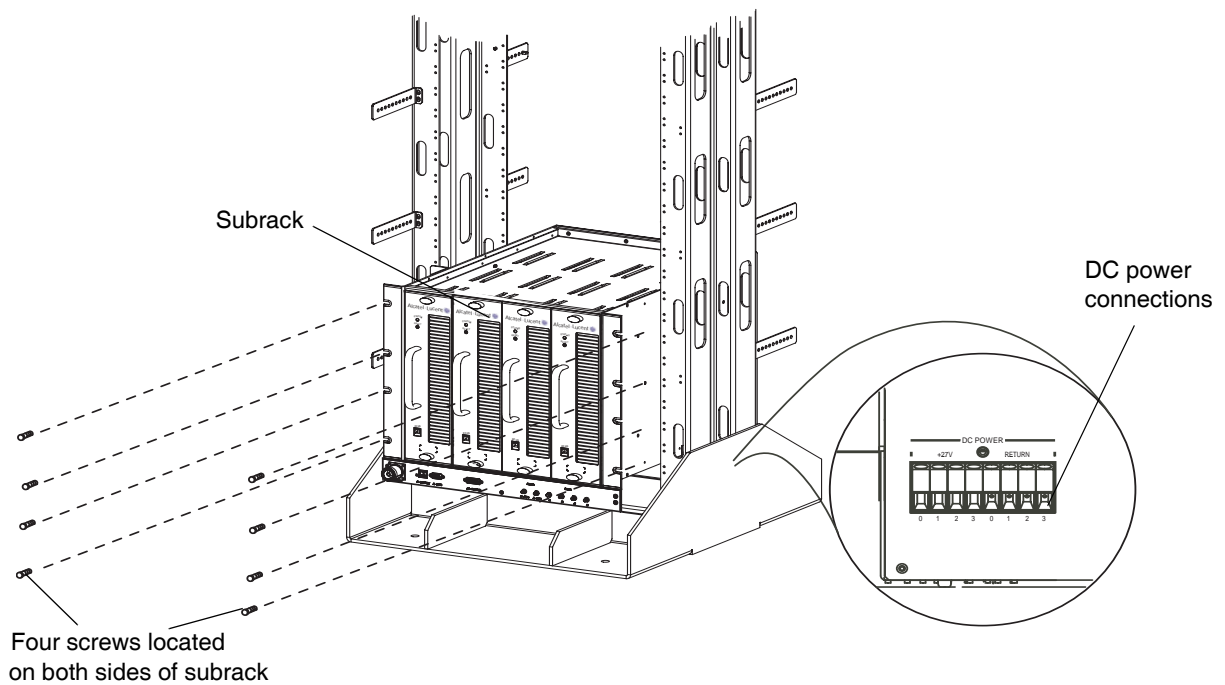

Figure 4-5 Subrack Removal and Replacement

**Filter**

To remove and replace the filter, shown in Figure 4-6, perform the steps in Table 4-8.

Table 4-9 Filter Removal and Replacement Procedure

Step	Action
1.	At subrack, set all MCPA OFF/ON/RESET switches to OFF
2.	At breaker panel, set all circuit breakers to OFF
3.	Disconnect and tag all cables from filter
4.	Remove four screws securing filter to shelf
5.	Install new filter in reverse order of removal

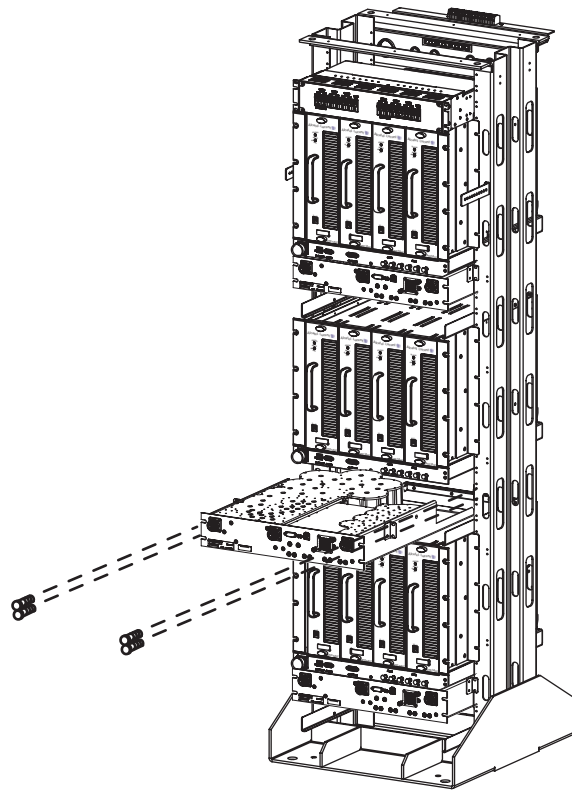

Figure 4-6 Filter Removal and Replacement



## Circuit Breaker Panel

To remove and replace the circuit breaker panel, shown in Figure 4-9, perform the steps in Table 4-11.

Table 4-10 Circuit Breaker Panel Removal and Replacement Procedure

Step	Action
1.	Turn off all +27 VDC BTS input power to PAF system
2.	Label and disconnect all input and output DC power connections from top rear of circuit breaker panel
3.	Remove screws from circuit breaker panel
4.	Remove circuit breaker panel from PAF frame
5.	Install circuit breaker panel replacement in reverse order of removal

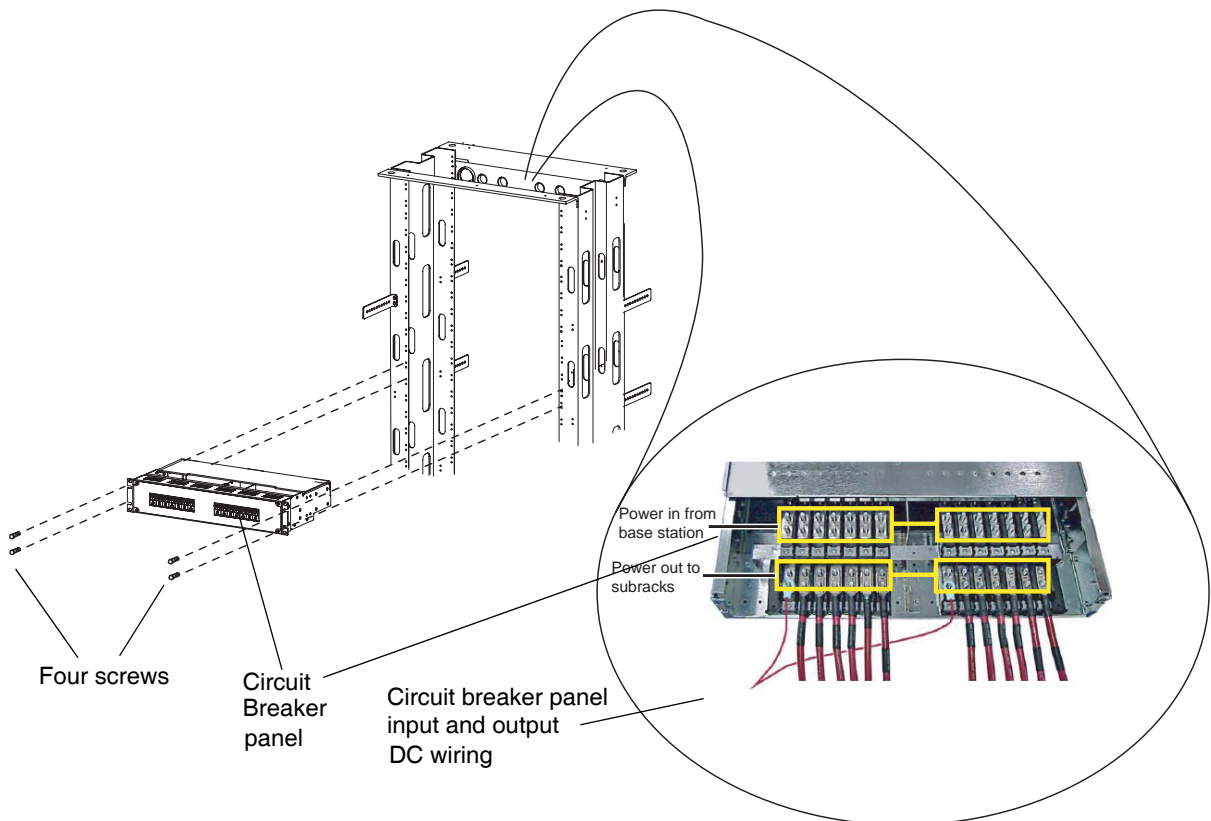

Figure 4-7 Breaker Panel Unit Removal and Replace

## **Return For Service Procedures**

When returning products to Powerwave, the following procedures will ensure optimum response.

### **Obtaining An RMA**

A Return Material Authorization (RMA) number must be obtained prior to returning equipment and to reduce delays in receiving repair service. Please contact our Repair Department at [rma@pwav.com](mailto:rma@pwav.com), (714) 466-1000 to obtain this number, or FAX your request to (714) 466-5816. For 24-hour technical support, call 1-800-473-1720 and select option 3.

### **Repackaging For Shipment**

To ensure safe shipment of a component, it is recommended that the original packing materials be reused. If not possible, use suitable shipping cartons and foam inserts to prevent damage in transit.

# Chapter 5 Specifications

## Introduction

This chapter provides system specifications that support the PAF-19XX-EX-XXX MCPA system. The system specifications are listed in Table 5-1

Table 5-1 System Specifications

<b>Electrical</b>	<b>Specifications/Features</b>
Downlink Frequency Range	1930 - 1990 MHz
RF Power Output per Antenna Port Measured @ Alpha, Beta, and Gamma Bulkheads	468 watts (56.7 dBm) per sector nominal AMPS 381 watts (55.8 dBm) per sector nominal CDMA
Max Input Power Handling (Composite RF per port)	0dB peak
Emissions Limits	Compliant to FCC Part 15, class B, Part 22 Cellular
Gain Variation vs. Frequency and Power	±0.6dB
Gain Variation vs. Temperature	±0.5dB for temperatures ranging from -5 to +45 °C
Input Port Return Loss	14 dB
Output Port Return Loss	14 dB
Operating DC Voltage Range	21 – 30 VDC
Alarms	RS485; Minor, Major, and Critical
<b>Mechanical</b>	<b>Specifications/Features</b>
PAF Connectors	Antenna Ports (Alpha, Beta, Gamma) Type 7/16 DIN Input Ports J1 - J6 Type - SMA Alarms, RS-486
Weight (3 sectors)	Empty: 428 lbs (194 kg) Loaded: 588 lbs (267 kg)
Dimensions (W x D x H)	22.75 (577.85 mm) x 26.5 (673.1 mm) X 78 (1981.2 mm)
Torques (Inch-Pounds): <u>Metal Machine Screws</u> 8-32 10-32 1/4-20 5/16-18 <u>Coaxial Connectors</u> SMA Type N Type 7/16 DIN	  20 to 24 32 to 40 70 to 80 140 to 160  5 to 6 12 to 15 220 to 230

Table 5-1 System Specifications (Continued)

<b>Environmental</b>	<b>Specifications/Features</b>
Operating Temperature Range	-5 - +45° C
Operating Humidity Range	5 -100% RH @ +40° C, Non-Condensing
Altitude	-60 to 4000 meters
Seismic	GR-63-CORE, Section 4.4.1, Zone 4
Lightning Surge Protection	3 kA @ 10/350 us waveform 5 kA @ 8/20 us waveform
Office Vibration	GR-63-Section 5.4.2
Transportation Bump	IEC 60068-2-29, Eb, 100 bumps per axis
Transportation Shock	IEC 60068-2-27, Ea, three 15 g, 11 ms, half-sine shocks, Z axis



## Powerwave Installation and Service Manual

### Worldwide Corporate Headquarters

1801 East St. Andrew Place  
Santa Ana, CA 92705 USA  
Tel: 714-466-1000  
Fax: 714-466-5800  
[www.powerwave.com](http://www.powerwave.com)

### Main European Office

Knarramasgatan 7 8tr  
164 40 Kista, Sweden  
Sweden  
Tel: +46 8 540 822 00  
Fax: +46 8 540 824 91

### Main Asia-Pacific Office

23 F Tai Yau Building  
181 Johnston Road  
Wanchai, Hong Kong  
Tel: +852 2512 6123  
Fax: +852 2575 4860

