

# Chapter 1

## Product Description

### 1.1 Introduction

This manual contains information and procedures for the installation, operation, and maintenance of the G3L-850-160 Multi-Carrier Power Amplifier (MCPA).

### 1.2 Scope of Manual

This manual is intended for use by service technicians familiar with similar types of equipment. It contains service information required for the equipment described and is current as of the printing date. Changes which occur after the printing date may be incorporated by a complete manual revision or alternatively as additions.

The manual is organized into the following chapters:

- Chapter 1 - Product Description
- Chapter 2 - Controls and Indicators
- Chapter 3 - Installation
- Chapter 4 - Maintenance
- Chapter 5 - Specifications

### 1.3 Product Description

The MCPA shown in Figure 1-1 is a linear, feed-forward multi-carrier power amplifier that operates in a 25MHz frequency band from 869 MHz to 894 MHz with an instantaneous bandwidth of 25 MHz. The instantaneous bandwidth is the maximum frequency band in which any two or more signals can occupy. The instantaneous bandwidth of the MCPA is set automatically.

The MCPA is modular in design and ideally suited for use in GSM, EDGE, CDMA, and W-CDMA base stations. The MCPA provides a gain of 63 dB to provide a 160 watt output. Refer to Figure 1-2 for the MCPA functional block diagram. Refer to Chapter 5 for the MCPA specifications.

### 1.4 Functional Description

The MCPA is a self-contained module typically operated in parallel with other identical MCPAs as part of a subrack assembly.

The MCPA consists of the following major functions:

- Preamplifier
- Main and error amplifiers
- Feed-forward loop control circuits
- Pilot tone generator

- Controller

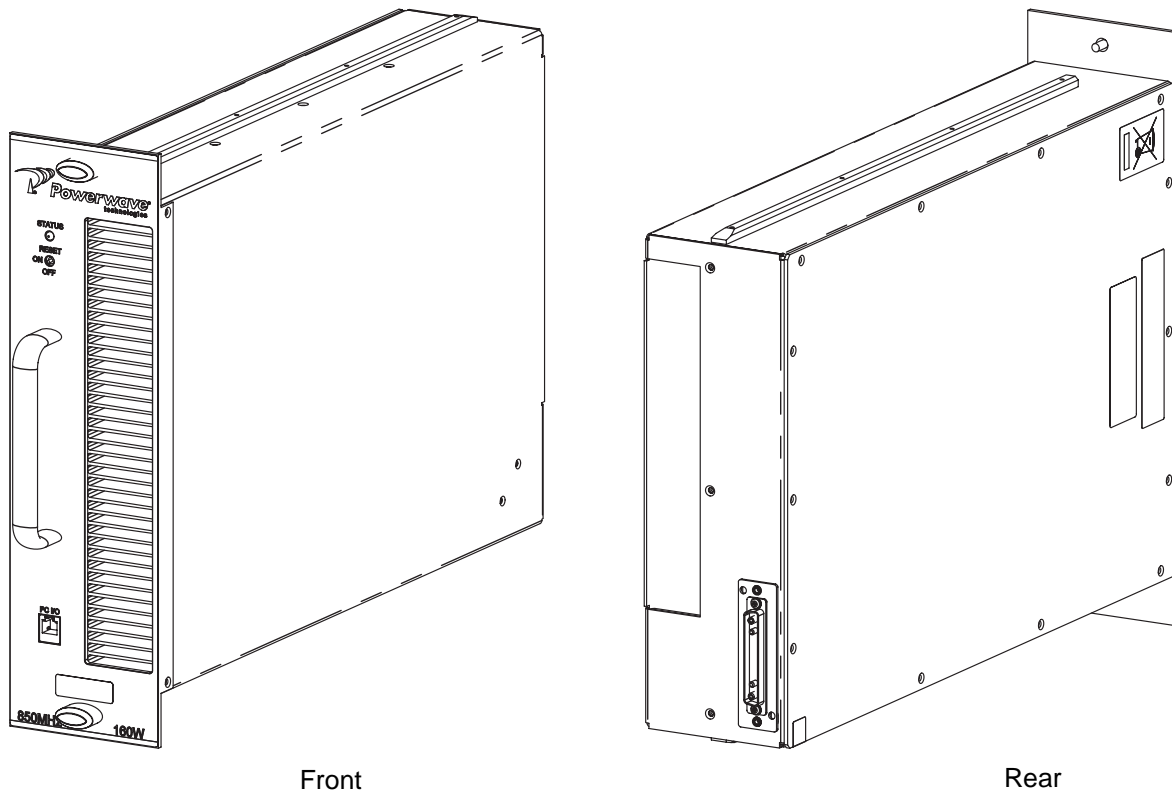

Figure 1-1 MCPA Front and Rear Views

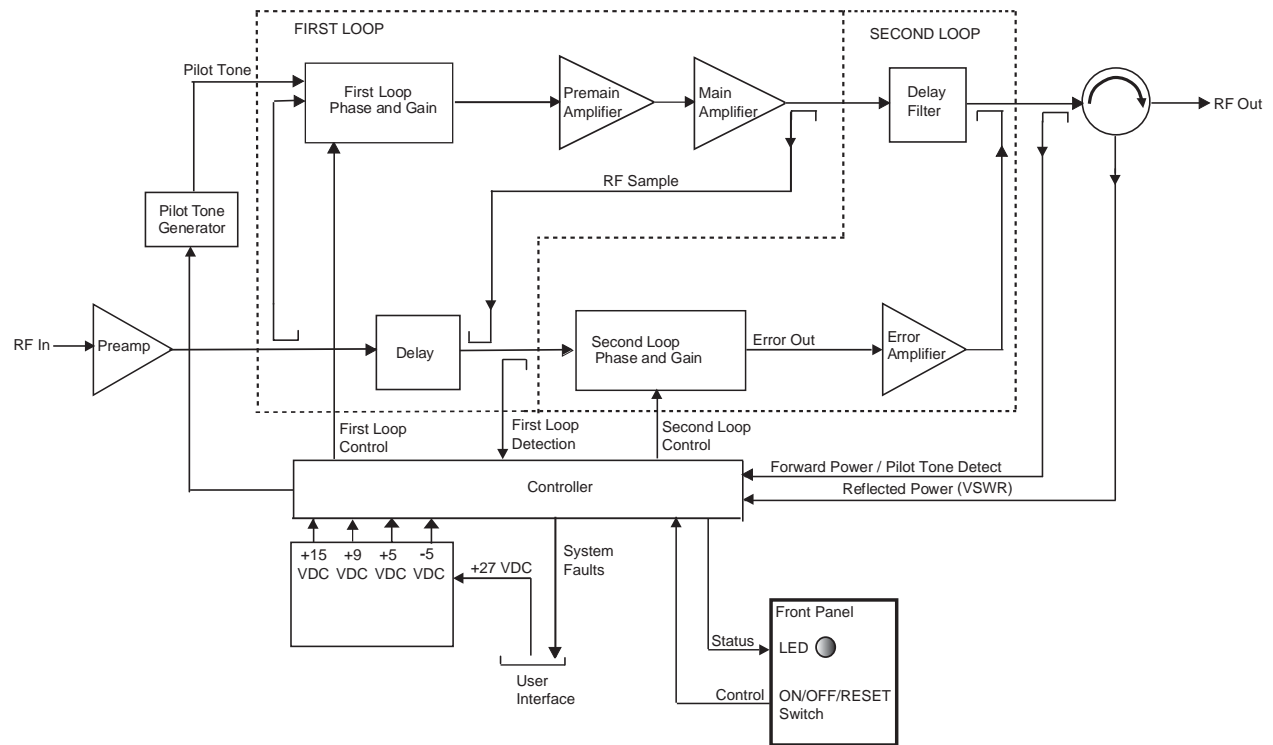

Figure 1-2 MCPA Functional Block Diagram

### 1.4.1 Preamplifier

The carrier (RF In) is applied to the input port of the MCPA and fed to the preamplifier stage where it is amplified using two stages of class A mode amplifiers. The output of the preamplifier is split into two paths, one to the main amplifier and one to the error amplifier.

### 1.4.2 Main and Error Amplifiers

The main amplifier provides the balance of gain and power in the 869 MHz to 894 MHz frequency band, using class AB amplification for maximum efficiency. The error amplifier and feed forward loops correct signal non-linearities introduced by the class AB main amplifier.

In the error amplifier, which operates in class A mode, the RF signal is coupled to an attenuator and phase shifter in the first feed-forward loop, phase shifted by 180 degrees and then amplified in the pre-main amplifier. The output from the pre-main amplifier is fed to the class AB main amplifier and then sampled using a coupler. The signal (RF sample) is combined with the main input signal and input to the second feed-forward loop.

There, the RF sample is attenuated, phase shifted 180 degrees, and fed to the error amplifier where it is amplified to a level identical to the sample output from the main amplifier. The output from the error amplifier (Error Out) is coupled back and added to the output from the main amplifier, with the control loops continuously making adjustments to cancel out any distortion in the final output signals.

### 1.4.3 Feed-forward Loop Control Circuits

The primary function of the first loop is to amplify the carrier signals and isolate an error signal for the second loop. It does this by amplifying the carrier signals and isolating an error signal which is passed to the second loop. The first loop control section phase shifts the main input signals by 180 degrees and constantly monitors the output for correct phase and gain.

The primary function of the second loop is to amplify the error signal to cancel out spurious products developed in the main amplifier. The input signal is amplified by a preamplifier and fed to a coupler and delay line. The signal from the coupler is fed to the attenuator and phase shifter in the first loop.

The second loop control section obtains a sample of the distortion added to the output signals by the main amplifiers. The signal is phase shifted 180 degrees, then fed to the error amplifier where it is amplified to the same power level as the input sample. The signal is then coupled to the main amplifier output. The final output is monitored by the second loop and adjusted to ensure that the signal distortion and intermodulation distortion on the final output is cancelled out.

During routine operation, all normal variations are automatically compensated for by the feed-forward loop control. If large variations occur beyond the adjustment range of the loop control, the controller shuts down the MCPA RF section and a loop fault is reported to the system.

### 1.4.4 Pilot Tone Generator

The pilot tone is an internally generated signal with a predetermined frequency, phase, and amplitude is known. If the pilot signal is suppressed at the amplifier output, then the distortion created by the main amplifier is also suppressed.

The pilot tone signal is injected into the first loop and detected at the feedforward output of the second loop. The pilot tone is coupled off of the main amplifier creating a second pilot tone that is attenuated and phase shifted 180 degrees to be used as the reference. The second pilot tone is amplified in the error amplifier and mixed with the signals from the main signal path.

The first and second pilot tones should cancel each other out in an ideal situation. If the output detector senses that the pilot tones do not cancel each other out, the information feeds back to control the gain and phase of both the main and error amplifier paths minimizing output distortion.

### 1.4.5 Controller

The controller constantly compares the active RF paths with internal references for dynamic correction of small variations through the RF feedback control circuits to maintain constant gain, and also provides the alarm monitoring and control for the MCPA.

A front panel mounted tri-color LED provides MCPA operational status to the local operator. The OFF/ON/RESET switch allows the operator to power on, power off or reset the MCPA. System faults are sent to a remote location through the user interface.

## 1.5 Cooling

The MCPA components are mounted on a heatsink and cooled by forced air flowing over the heatsink fins. System fans draw external air through the MCPA front panel inlet and exhaust air through the MCPA rear panel outlet. The internal temperature is monitored to keep the MCPA within the specified operating temperature.

## 1.6 Power Distribution

The host system provides +27 VDC power for the MCPA. The DC/DC converter and voltage regulator in the MCPA converts the +27 VDC to +15 VDC, +9 VDC, +5 VDC, and -5 VDC for internal use. The MCPA has no built-in short-circuit protection.

The MCPA operates at full power if the system DC supply is within 26 to 30 VDC. The MCPA shuts down if the applied DC power is less than 21.5 VDC or greater than 30.5 VDC.