

# Chapter 5 Maintenance

## 5-1 Introduction

This chapter contains periodic maintenance and performance test procedures for the G3L-850-135 Multi-Carrier Power Amplifier (MCPA).

 **Note** Check your sales order and equipment warranty before attempting to service or repair the unit. Do not break the seals on equipment under warranty or the warranty will be null and void. Do not return equipment for warranty or repair service until proper shipping instructions are received from the factory.

## 5-2 Periodic Maintenance

Periodic maintenance requirements and the intervals at which the tasks should be performed are listed in Table 5-1.

**Table 5-1. Periodic Maintenance**

Task	Interval	Action
Inspection: Cables and Connectors	12 Months	Inspect signal and power cables for frayed insulation. Check RF connectors to ensure that they are tight.
Performance Tests	12 Months	Perform annual test per paragraph 5-4.
Clean Fans/Heat Sinks	3 Months	Inspect for debris. Remove dust with a soft cloth/brush or vacuum cleaner.

## 5-3 Test Equipment Required For Test

Test equipment required to test the amplifier is listed in Table 5-2. Equivalent test equipment may be substituted for any item, keeping in mind that a thermistor type power meter is required.

 **Note** All RF test equipment required must be calibrated to 0.05 dB resolutions. Any deviation from the nominal attenuation must be accounted for and factored into all output readings.



Table 5-2. Test Equipment Required

Nomenclature	Manufacturer	Model
Signal Generator	Agilent	8656B
20 dB Attenuator, 250 Watt	Bird	
20 dB Attenuator, 20 Watt (2 each)	Bird	Tenuline
Spectrum Analyzer	Agilent	8560E
Coax Directional Coupler	Agilent	778D
Power Meter / Sensor	Agilent	437B / 8481A
Arbitrary Waveform Generator	Sony	AWG2021
Network Analyzer	Agilent	8753C

\* Any Equipment substitutions should have equivalent specifications.

## 5-4 Amplifier Performance Test

Performance testing should be conducted every 12 months to ensure that the amplifier system meets the operational specifications listed in Table 5-3. Also verify system performance after any amplifier module is replaced in the field.

The test equipment required to perform the testing is listed in Table 5-2, and the test setup is shown in Table 5-1.

 **Note** The frequencies used in this test are typical for an amplifier with a 25 MHz band from 869 MHz to 894 MHz. Select evenly spaced F1, F2, F3, and F4 frequencies that cover the instantaneous bandwidth of your system.

To check amplifier performance, proceed as follows:

 **WARNING** Do not apply any RF signals to the amplifier input until instructed to do so.

 **CAUTION** Ensure that the correct amount of attenuation is used between the amplifier RF connections and the test equipment to prevent overdrive of the amplifier or the test equipment.

### 5-4.1 Amplifier Spurious Emissions Test:

1. Connect the test equipment as shown in Figure 5-1.
2. Configure the signal source to produce four frequencies evenly spaced across the instantaneous bandwidth to be used for the amplifier under test.
3. Adjust the output of the signal source to excite the amplifier to its rated output.
4. Use the spectrum analyzer to measure the spurious emissions performance.
5. Record test data in Table 5-3. Verify that the data are within the specifications shown in Table 1-2.
6. Reduce the output of the signal source to minimum.

7. Switch off the Main Power Switch on the amplifier under test.

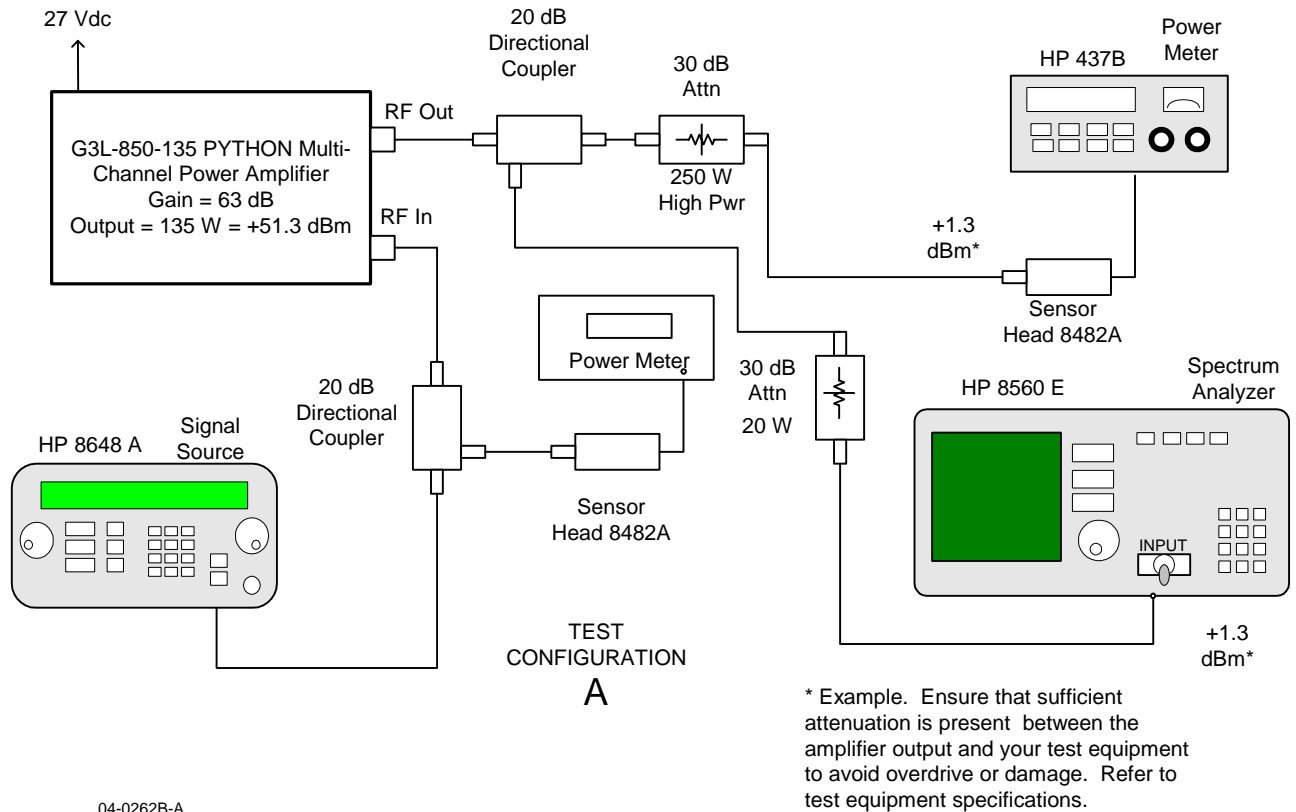

04-0262B-A

**Figure 5-1. Amplifier Test Setup Diagram – Configuration A**

#### 5-4.2 Gain Test:

1. Disconnect:
  - a. Spectrum analyzer
  - b. Signal source.
  - c. Power Meter and Sensor Head.
2. Connect the network analyzer as shown in Figure 5-2.
3. Set network analyzer as follows:
  - a. Power output to -11 dBm max.
  - b. Frequency start to 869 MHz.
  - c. Frequency stop to 894 MHz.
  - d. Normalize the network analyzer for gain and return loss.
4. Switch on the amplifier under test, and ensure that the STATUS switch is in the center position.
5. Check the amplifier gain across the band from 869 MHz to 894 MHz. Gain should be as specified in Table 1-2. Record test data in Table 5-3.

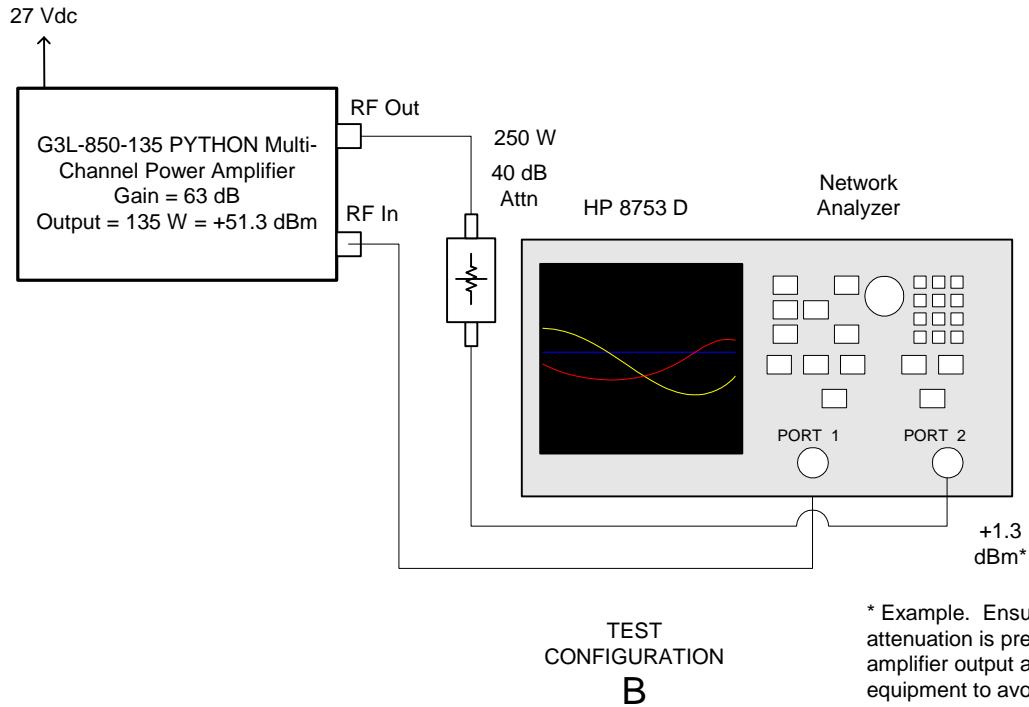

\* Example. Ensure that sufficient attenuation is present between the amplifier output and your test equipment to avoid overdrive or damage. Refer to test equipment specifications.

04-0263B-A

**Figure 5-2. Amplifier Test Setup – Configuration B**

### 5-4.3 Input Return Loss:

1. Retain the test configuration shown in Figure 5-2.
2. Read and record the  $S_{11}$  return loss measurement on network analyzer. Record test data in Table 5-3.
3. Switch off the amplifier under test.
4. Disconnect the test equipment.

**5-4.4 Test Data Sheet**

Record the amplifier's performance test data below.

DATE \_\_\_\_\_ MODULE S/N \_\_\_\_\_

*Test Conditions:*

Load and Source Impedance: 50 Ohms

VSWR: < 1.5:1

Supply Voltage: +27 Vdc ±0.1 Vdc

**Table 5-3. Amplifier Performance Data**

Test	Specification	Min	Max	Data
RF Gain	Vcc = 27 Vdc PO = See table 1-4 Freq. = 869 – 894 MHz	62.5.0 dB	63.5 dB	
Spurious Emissions	Vcc = 27 Vdc PO = See table 1-2 869 – 894 MHz Band		-62 dBc	
Gain Flatness	Vcc = 27 Vdc PO = See table 1-2 869 – 894 MHz Band		±0.5 dB	
Input Return Loss	Vcc = 27 Vdc PO = See table 1-2 869 – 894 MHz Band		-16 dB	

PASS \_\_\_\_ FAIL \_\_\_\_

Tested by .



## **5-5 Return For Service Procedures**

When returning products to Powerwave, the following procedures will ensure optimum response.

### **5-5.1 Obtaining An RMA**

A Return Material Authorization (RMA) number must be obtained prior to returning equipment to the factory for service. Please contact our Repair Department at (714) 466-1000 to obtain this number, or FAX your request to (714) 466-5800. Failure to obtain this RMA number may result in delays in receiving repair service.

### **5-5.2 Repackaging For Shipment**

To ensure safe shipment of the amplifier, it is recommended that the original package designed for shipping the amplifier be reused. If it is not available, contact Powerwave's Customer Service Department for packing materials.