

Section 5. Maintenance

5-1 Introduction

This section contains periodic maintenance and performance test procedures for the G3L-1929-120 Multi-Carrier Power Amplifier (MCPA).

NOTE

Check your sales order and equipment warranty before attempting to service or repair the unit. Do not break the seals on equipment under warranty or the warranty will be null and void. Do not return equipment for warranty or repair service until proper shipping instructions are received from the factory.

5-2 Periodic Maintenance

Periodic maintenance requirements and the intervals at which the tasks should be performed are listed in table 5-1.

Table 5-1 Periodic Maintenance

Task	Interval	Action
Inspection: Cables and Connectors	12 Months	Inspect signal and power cables for frayed insulation. Check RF connectors to ensure that they are tight.
Performance Tests	12 Months	Perform annual test per paragraph 5-4.
Clean Fans/Heat Sinks	3 Months	Inspect for debris. Remove dust with a soft cloth/brush or vacuum cleaner.

5-3 Test Equipment Required For Test

Test equipment required to test the amplifier is listed in table 5-2. Equivalent test equipment may be substituted for any item, keeping in mind that a thermistor type power meter is required.

NOTE

All RF test equipment required must be calibrated to 0.05 dB resolution. Any deviation from the nominal attenuation must be accounted for and factored into all output readings.

Table 5-2 Test Equipment Required

Nomenclature	Manufacturer	Model
Signal Generator	H.P.	8656B
20 dB Attenuator, 250 Watt	Bird	Tenuline
20 dB Attenuator, 20 Watt (2 each)	Bird	Tenuline
Spectrum Analyzer	H.P.	8560E
Coax Directional Coupler	H.P.	778D
Power Meter / Sensor	H.P.	437B / 8481A
Arbitrary Waveform Generator	Sony	AWG2021
Network Analyzer	H.P.	8753C

5-4 Performance Test

Performance testing should be conducted every 12 months to ensure that the amplifier system meets the operational specifications listed in Table 5-3. Also verify system performance after any amplifier module is replaced in the field. The test equipment required to perform the testing is listed in table 5-2, and the test setup is shown in figure 5-1.

NOTE

The frequencies used in this test are typical for an amplifier with a 60 MHz band from 1930 MHz to 1990 MHz. Select evenly spaced F1, F2, F3, and F4 frequencies that cover the instantaneous bandwidth of your system.

5-4.1 Amplifier Performance Test

To perform these tests, proceed as follows:

Connect test equipment as shown in figure 5-1.

WARNING

Do not apply any RF signals at this time.

5-4.1.1 Amplifier Spurious Emissions Test:

With the RF input signal to the amplifier set to be as shown in Figure 5-1, use the spectrum analyzer to measure the spurious emissions performance. Record test data in Table 5-3. Verify that it is within the specifications shown in table 1-2. Switch tested amplifier to OFF.

5-4.1.2 Gain Test:

1. Disconnect spectrum analyzer from test setup, and connect the network analyzer.
2. Set network analyzer as follows:
 - A. Power output to -10 dBm max.
 - B. Frequency start to 1930 MHz.
 - C. Frequency stop to 1990 MHz.
 - D. Normalize the network analyzer for gain and return loss.
3. Check the amplifier gain across the band from 1930 MHz to 1990 MHz. Gain should be as specified in table 1-1. Record test data in table 5-3.

5-4.1.3 Input Return Loss:

Read and record the S_{11} return loss measurement on network analyzer. Record test data in table 5-3.

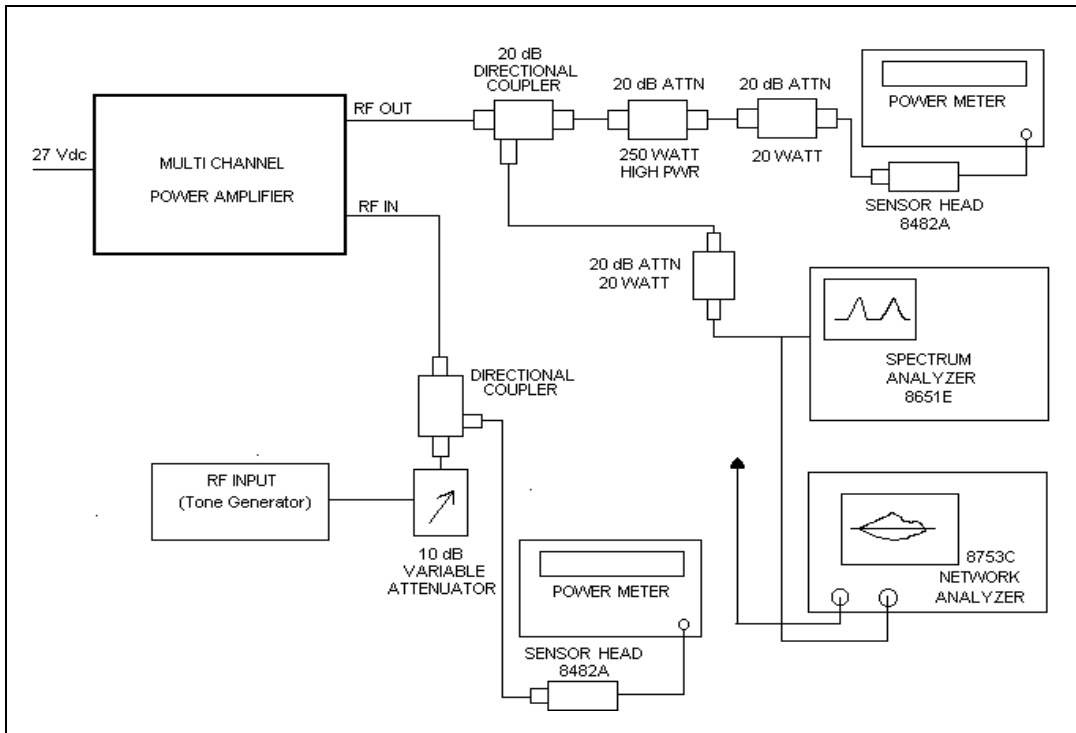

Figure 5-1 Amplifier Test Setup Diagram

Table 5-3 G3L-1929-120 Amplifier Test Data Sheet

DATE _____ MODULE S/N _____

Test Conditions:

Load and Source Impedance: 50 Ohms
 VSWR: < 1.5:1
 Supply Voltage: +27 Vdc ±0.1 Vdc

Test	Specification	Min	Max	Data
RF Gain	Vcc = 27 Vdc PO = See table 1-4 Freq. = 1930 – 1990 MHz	57.0 dB	58.0 dB	
Spurious Emissions	Vcc = 27 Vdc PO = See table 1-4 1930 – 1990 MHz Band		-65 dBc	
Gain Flatness	Vcc = 27 Vdc PO = See table 1-4 1930 – 1990 MHz Band		±0.5 dB	
Input Return Loss	Vcc = 27 Vdc PO = See table 1-4 1930 – 1990 MHz Band		-14 dB	

PASS _____ FAIL _____

Tested by _____

5-5 Field Replacement of the Module

The GL3-1929-120 multi-carrier power amplifier module can be replaced in the field on site by a qualified technician with experience maintaining RF power amplifiers and similar equipment:

To replace a power amplifier module, proceed as follows:

1. Set On/Off switch on the front panel of the amplifier module to Off (down).
2. Loosen the two thumbscrews that secure amplifier module to the subrack.

CAUTION

When removing the amplifier from the subrack, it is very important to support the amplifier such that the rear of the module does not suddenly drop when the guide rail disengages from the track. A drop such as this could damage the rear 21WA4 multipin connector.

3. With steady even pressure, use handle on front of amplifier to pull module out of subrack.
4. Install replacement in reverse order of steps 1 through 3 above.