

# Section 4 Principles of Operation

## 4-1 Introduction

This section contains a functional description of the single-carrier SCA 9321-30C amplifier.

## 4-2 RF Input Signal

The maximum input power should not exceed the levels to produce the maximum rated RF output power in table 1-1. This level is approximately 0 dBm, but should be set through the base-transceiver station's software interface. See the BTS manual for detailed instructions.

## 4-3 RF Output Load

The load impedance should be as good as possible (1.5:1 or better) in the working band for good power transfer to the load.

## 4-4 SCA 9321-30C Amplifier

The amplifier, figure 4-1, has an average output power of 30 watts, and is designed to support transmission in GMSK and EDGE modulation. With an input signal of approximately 0 dBm, the amplifier will operate at its rated output power. The amplifier is comprised of:

- Driver Amplifier
- Main Amplifier
- Multifunction Board
- DC/DC Converter Module

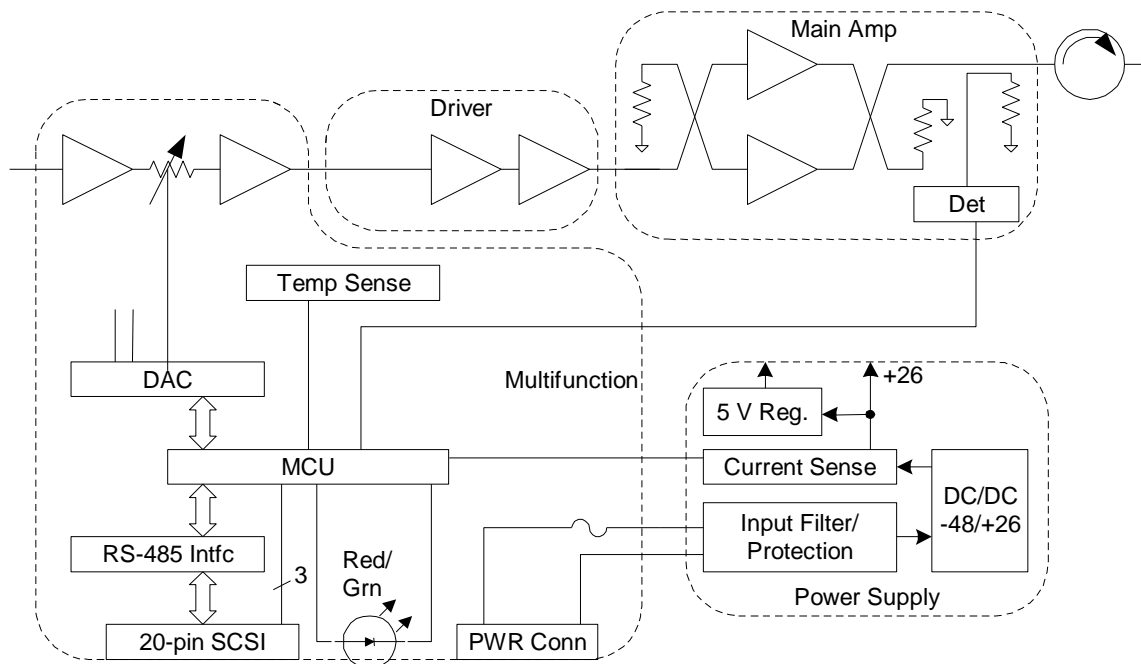

Figure 4-1 SCA 9321-30C Amplifier Block Diagram

#### 4-4.1 Driver Amplifier

The driver amplifier is a two-stage amplifier which provides approximately 28 dB of gain in the 25 MHz frequency band from 869 to 894 MHz. The amplifier is mounted directly on a heat sink, which is temperature monitored by a thermal sensor.

#### 4-4.2 Main Amplifier

The main amplifier is a single-stage Class AB amplifier with approximately 13 dB gain and a P1dB of +50 dBm. The amplifier's output is protected from output mismatches. The amplifier is designed to meet spectral mask requirements for GSM and EDGE signals when operated up to +45.2 dBm. The amplifier is mounted directly on a heat sink.

#### 4-4.3 Power Distribution

The amplifier module operates on a -48 VDC nominal power supply consuming 2.9 amps (typically) current at full power. A DC/DC converter to supply internal circuitry with +26 VDC and +5 VDC.

#### 4-4.4 Multifunction Board

The multifunction board enables communication between the amplifier and the base-transceiver station in which it is installed, and stores information about the amplifier. It includes gain control and two gain stages providing 7 dB gain. The multifunction board also monitors several amplifier performance parameters and reports output power so that the BTS can maintain the output power within specified limits. When these parameters are beyond acceptable levels, the amplifier will alarm. The multifunction board is mounted directly on a heat sink, which is temperature monitored by a thermal sensor.

The alarms are:

*Temperature Alarm* - If the internal temperature reaches 90°C, the PA shuts down and communicates an alarm through the digital interface.

*DC/DC Alarm* - If the output voltage of the converter falls below 23.5V, the PA shuts down and communicates an alarm through the digital interface.

*Over-current Alarm* - If the output current of the DC/DC converter goes above a nominal threshold (7.5 A), the PA shuts down and communicates an alarm through the digital interface.

*Communication Alarm* - If the serial interface detects an error in transmission (parity, overrun, framing), an alarm is sent for one burst only during the very next burst. The PA operation is not affected.