



INSTALLATION & SERVICE
MANUAL

MULTICHANNEL
POWER AMPLIFIER
NTGY81AC

1930-1990 MHz
50 WATTS AVERAGE POWER

04 April 2002

Powerwave Technologies, Inc.
1801 E. St. Andrew Place
Santa Ana, CA 92705

Tel: (714) 466-1000
Fax: (714) 466-5800
Web Site: www.powerwave.com

TABLE OF CONTENTS

<u>Par. No.</u>	<u>Section 1 General Description</u>	<u>Page No.</u>
1-1	Introduction.....	1-1
1-2	General Description.....	1-1
1-3	Functional and Physical Specifications.....	1-1
 Section 2 Installation 		
2-1	Introduction.....	2-1
2-2	Electrical Service Recommendations.....	2-1
2-3	Unpacking and Inspection.....	2-1
2-4	Installation Instructions.....	2-2
2-5	+26 VDC Power and Ground Connector P1.....	2-2
2-6	Alarms and Sensing Connector P2.....	2-3
2-7	Differential IIC Clock, Receive, and Transmit Connector P3.....	2-4
2-8	IIC, Power, Alarms, and Controls Connector P4.....	2-4
2-9	IIC, RS485, Power, and Other Signals Connector P5.....	2-6
 Section 3 Operating Instructions 		
3-1	Introduction.....	3-1
3-2	Initial Start-Up and Operating Procedures.....	3-1
 Section 4 Principles of Operation 		
4-1	Introduction.....	4-1
4-2	RF Input Signal.....	4-1
4-3	RF Output Load.....	4-1
4-4	Amplifier Functional Description.....	4-1
4-4.1	Input Amplifier.....	4-1
4-4.2	Predistortion Amplifier.....	4-1
4-4.3	Driver Amplifier.....	4-2
4-4.4	Main Amplifier.....	4-2
4-4.5	Multifunction Board.....	4-2
4-5	Amplifier Module Cooling.....	4-2
4-5	Power Distribution.....	4-2

TABLE OF CONTENTS (Continued)

<u>Par. No.</u>	Section 5 Maintenance	<u>Page No.</u>
5-1	Introduction.....	5-1
5-2	Periodic Maintenance	5-1
5-3	Test Equipment Required For Test	5-1
5-4	Performance Test.....	5-2
5-4.1	Amplifier Performance Test.....	5-2
5-5	Field Replacement of the Module.....	5-5

Section 6 Troubleshooting

6-1	Introduction.....	6-1
6-2	Troubleshooting.....	6-1
6-3	Return for Service Procedures	6-1
6-3.1	Obtaining an RMA	6-1
6-3.2	Repackaging for Shipment	6-1

LIST OF ILLUSTRATIONS

<u>Figure No.</u>		<u>Page No.</u>
1-1	NTGY81AC Multichannel Power Amplifier	1-3
2-1	+26 Vdc Power and Ground Connector P1	2-2
2-2	Alarms and Sensing Connector P2	2-3
2-3	Differential IIC Clock, Receive, and Transmit Connector P3.....	2-4
2-4	IIC, Power, Alarms, and Controls Connector P4	2-4
2-5	IIC, RS485, Power and Other Connector P5.....	2-6
4-1	NTGY81AC Multichannel Power Amplifier Functional Block Diagram	4-2
5-1	NTGY81AC Amplifier Test Setup Diagram	5-3

LIST OF TABLES

<u>Table No.</u>		<u>Page No.</u>
1-1	NTGY81AC Multichannel Power Amplifier Functional Specifications.....	1-2
2-1	+26 Vdc Power and Ground Connector P1 Definition	2-2
2-2	Alarms and Sensing Connector P2 Definition	2-3
2-3	Differential IIC Clock, Receive, and Transmit Connector P3 Definition.....	2-4
2-4	IIC, Power, Alarms, and Controls Connector P4 Definition	2-5
2-5	IIC, RS485, Power and Other Connector P5 Definition.....	2-6
5-1	Periodic Maintenance	5-1
5-2	Test Equipment Required.....	5-2
5-3	Multichannel Power Amplifier NTGY81AC Test Data Sheet	5-4
6-1	Troubleshooting.....	6-1

GENERAL DESCRIPTION

1-1. INTRODUCTION

This manual contains information and procedures for installation, operation, and maintenance of Powerwave's model NTGY81AC multichannel power amplifier (MCPA). The manual is organized into six sections as follows:

- Section 1. General Description
- Section 2. Installation
- Section 3. Operating Instructions
- Section 4. Principles of Operation
- Section 5. Maintenance
- Section 6: Troubleshooting

1-2. GENERAL DESCRIPTION

The NTGY81AC is a linear, multichannel power amplifier that operates in the 60 MHz frequency band from 1930 MHz to 1990 MHz. It is designed to be mounted in an enclosure with EMI containment. Its flat base plate allows for mounting on a flat thermal-absorbing surface to provide adequate heat dissipation.

Each amplifier module has a power, alarm, and control connector that allows the host system to monitor the amplifier module performance. Primary power for the amplifier is +26 Vdc.

1-3. FUNCTIONAL AND PHYSICAL SPECIFICATIONS

Functional and physical specifications for the amplifier are listed in table 1-1.

Table 1-1. NTGY81AC Multichannel Power Amplifier Functional Specifications

Frequency Range	1930-1990 MHz (60 MHz Bandwidth)		
Maximum Average Input Power	13 dBm		
Continuous Average Output Power	50 Watts		
Spurious Emissions @ Maximum Rated Output Power (50 W / 47 dBm)	<u>Frequency Offset</u>	<u>Requirement</u>	
		<u>Max.</u>	<u>Min.</u>
	0.885-1.25 MHz	-47 dBc	30 kHz
	1.25-1.98 MHz	-16.5 dBm	37.5 kHz
1.98-2.25 MHz	-58 dBc	30 kHz	
>2.25 MHz	-15 dBm	1 MHz	
RF Gain	47 ±2 dB		
Gain Flatness:	± 0.2 dB for any 1.25-MHz band within frequency range.		
Output Protection:	Mismatch Protected		
Input Port Return Loss:	VSWR 2:1 Max.		
Out of Band Spurious:	Less than -15 dBm / 1 MHz		
DC Input Power:	+26 ± 0.5 Vdc, 260 mV p-p max. ripple, ≤500 watts		
Operating Temperature:	-15 °C. to +85 °C. (heatsink temperature)		
Storage Temperature:	-40 °C. to +85 °C.		
Operating Humidity:	5 % - 95 % Relative Humidity (Noncondensing)		
Storage Humidity:	5 % - 95 % Relative Humidity (Noncondensing)		
Interface Connectors:			
RF Input-----	SMA Female		
RF Output -----	SMA Female		
+26 Vdc Power and Ground -----	3W3 D-Sub (Connector P1)		
Alarms and Sensing -----	14-Position Micro-Fit 3.0 (Connector P2)		
Differential IIC Clock, Rcv., Xmit. ---	6-Position Micro-Fit 3.0 (Connector P3)		
IIC, Power, Alarms, Controls-----	26-Position High Density D-Sub (Connector P4)		
IIC, RS485, Power, Other Signals --	18-Position Micro-Fit 3.0 (Connector P5)		
Dimensions (inches):	11.00 x 14.50; height: 1.70		

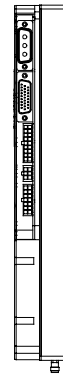
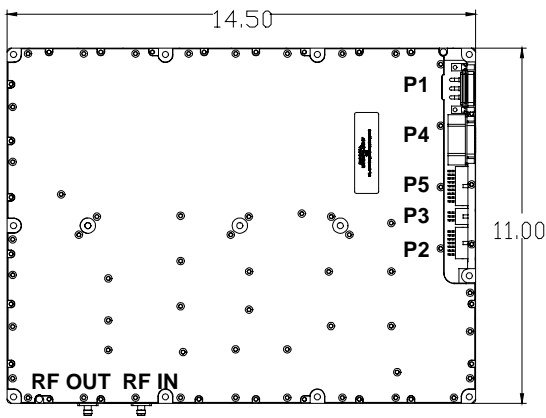
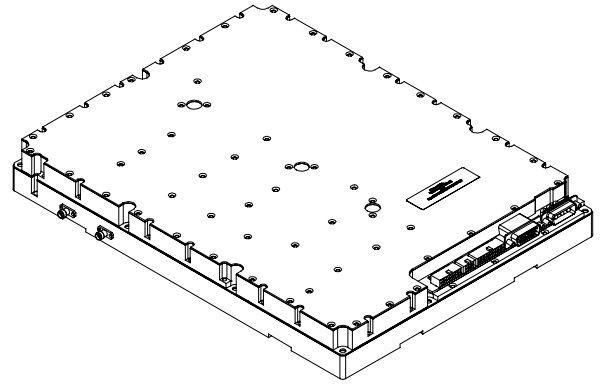
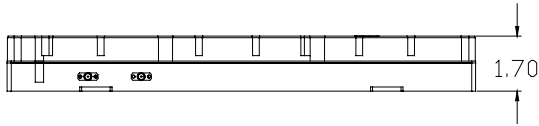

Figure 1-1. NTGY81AC Multichannel Power Amplifier

INSTALLATION

2-1. INTRODUCTION

This section contains unpacking, inspection, and installation instructions and recommendations for the Model NTGY81AC Multi Channel Power Amplifier. Carefully read all material in this section prior to equipment unpacking or installation. Also read and review the operating procedures in Section 3 prior to installing the equipment. It is important that the licensee perform these tasks correctly and in good faith. If applicable, carefully read the appropriate parts of the Federal Communications Commission (FCC) rules to determine how they apply to your installation. **DON'T TAKE CHANCES WITH YOUR LICENSE.**

2-2. ELECTRICAL SERVICE RECOMMENDATIONS

Powerwave Technologies recommends that proper AC line conditioning and surge suppression be provided on the primary AC input to the +26 Vdc power source. All electrical service should be installed in accordance with the National Electrical Code, any applicable state or local codes, and good engineering practice. Special consideration should be given to lightning protection of all systems in view of the vulnerability of most transmitter sites to lightning. Lightning arrestors are recommended in the service entrance. Straight, short ground runs are recommended. The electrical service must be well grounded.

Each amplifier system should have its own circuit breaker, so a failure in one does not shut off the whole installation. Circuit breakers should be thermal type, capable of handling the maximum anticipated inrush current, in a load center with a master switch.

2-3. UNPACKING AND INSPECTION

This equipment has been operated, tested and calibrated at the factory. Carefully open the container(s) and remove the amplifier module(s). Retain all packing material that can be reassembled in the event that the unit must be returned to the factory.

CAUTION

Exercise care in handling equipment during inspection to prevent damage caused by rough or careless handling.

Visually inspect the amplifier module for damage that may have occurred during shipment. Check for evidence of water damage, bent or warped chassis, loose screws or nuts, or extraneous packing material in the connector. If the equipment is damaged, a claim should be filed with the carrier once the extent of any damage is assessed. We cannot stress too strongly the importance of IMMEDIATE careful inspection of the equipment and the subsequent IMMEDIATE filing of the necessary claims against the carrier if necessary. If possible, inspect the equipment in the presence of the delivery person. If the equipment is damaged, the carrier is your first area of recourse. If the equipment is damaged and must be returned to the factory, write or phone for a return authorization. Powerwave may not accept returns without a return authorization. Claims for loss or damage may not be withheld from any payment to Powerwave, nor may any payment due be withheld pending the outcome thereof. **WE CANNOT GUARANTEE THE FREIGHT CARRIER'S PERFORMANCE**

2-4. INSTALLATION INSTRUCTIONS (Refer to figure 1-1)

The NTGY81AC amplifier module is designed for installation on a heatsink that permits access to the module for connection of RF cables and the power, alarm, and control connector.

To install the amplifier proceed as follows:

1. Install amplifier on heatsink with thermally conductive material inserted between amplifier module and heatsink, and secure in place with appropriate mounting screws.
2. Connect the antenna cable to **RF OUT** female SMA connector.
3. Connect the transceiver output cable to **RF IN** female SMA connector.

WARNING

Turn off external primary DC power before connecting any cables.

4. Connect power, alarm, and control cables to matching P1 through P5 connectors. Refer to paragraphs 2-5 through 2-9 following.
6. Check your work before applying DC voltage to the system. Make certain all connections are tight and correct.
7. Measure primary DC input voltage. DC input voltage should be $+26 \pm 0.5$ Vdc. If the DC input voltage is above or below the limits, call and consult Powerwave before you turn on your amplifier system.
8. Refer to section 3 for initial turn-on and checkout procedures.

2-5. +26 VDC POWER AND GROUND CONNECTOR P1

The +26 Vdc power and ground connections on the amplifier are made through an 3-pin female D-Sub connector (figure 2-1) and are listed and described in table 2-1.

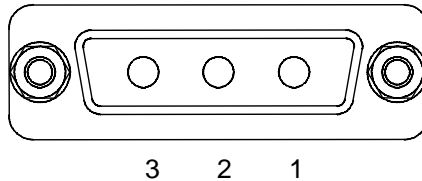

Figure 2-1. +26 Vdc Power and Ground Connector P1

Table 2-1. +26 Vdc Power and Ground Connector P1 Definition

PIN	SIGNAL	DESCRIPTION
1	+26V	+26 Vdc for MCPA
2	+26V_RTN	+26 Vdc return, grounded to MCPA chassis ground.
3	Chassis Gnd.	Chassis Ground

2-6. ALARMS AND SENSING CONNECTOR P2

The alarms and sensing connections on the amplifier are made through a 14-pin micro-fit connector (figure 2-2) and are listed and described in table 2-2.

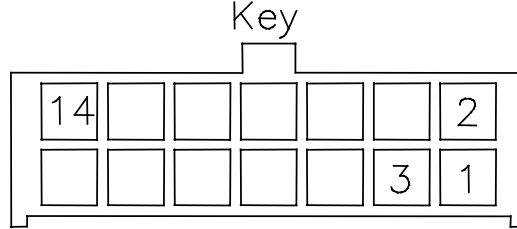

Figure 2-2. Alarms and Sensing Connector P2

Table 2-2. Alarms and Sensing Connector P2 Definition

PIN	SIGNAL	DESCRIPTION
1	+5V_AIM	5-volt supply for the AIM; routed directly to the fan assembly / AIM connector
2	+5V_AIM_RTN	5-volt supply return for the AIM; routed directly to the fan assembly / AIM connector
3	+26V_ALARM	26V HPCA alarm input
4	+15V_ALARM	15V HPCA alarm input
5	REMOTE_SENSE	Remote sense for HPCA; connected directly to 26V supply
6	REMOTE_SENSE_RTN	Remote sense return for HPCA; connected directly to 26V supply return
7	+5V_ALARM	5V HPCA alarm input
8	NC	Not connected
9	26ARTN	26V alarm return connected to 26V return on the MCPA
10	ARTN	5V and 15V alarm return connected to 26V return on the MCPA
11	+26V_FAN	26V supply for the fans; routed to fan assembly / AIM connector
12	+26V_FAN_RTN	26V supply return for the fans; routed to fan assembly / AIM connector
13	+26V_FAN	26V supply for the fans; routed to fan assembly / AIM connector
14	+26V_FAN_RTN	26V supply return for the fans; routed to fan assembly / AIM connector

2-7. DIFFERENTIAL IIC CLOCK, RECEIVE, AND TRANSMIT CONNECTOR P3

The alarms and sensing connections on the amplifier are made through a 6-pin micro-fit connector (figure 2-3) and are listed and described in table 2-3.

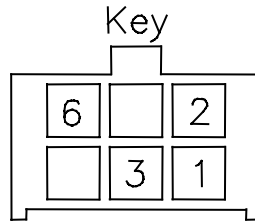

Figure 2-3. Differential IIC Clock, Receive, and Transmit Connector P3

Table 2-3. Differential IIC Clock, Receive, and Transmit Connector P3 Definition

PIN	SIGNAL	DESCRIPTION
1	IIC_CLK+	Differential IIC Clock to the DPM
2	IIC_CLK-	Differential IIC Clock to the DPM
3	IIC_RX_DATA+	Differential IIC Receive Data (from DPM)
4	IIC_RX_DATA-	Differential IIC Receive Data (from DPM)
5	IIC_TX_DATA+	Differential IIC Transmit Data (to DPM)
6	IIC_TX_DATA-	Differential IIC Transmit Data (to DPM)

2-8. IIC, POWER, ALARMS, AND CONTROLS CONNECTOR P4

The alarms and sensing connections on the amplifier are made through a 26-pin high density D-Sub connector (figure 2-4) and are listed and described in table 2-4.

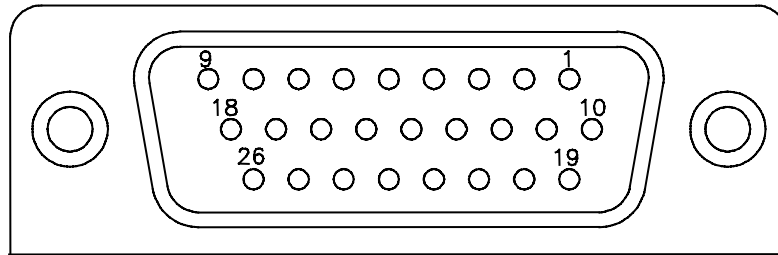

Figure 2-4. IIC, Power, Alarms, and Controls Connector P4

Table 2-4. IIC, Power, Alarms, and Controls Connector P4 Definition

PIN	SIGNAL	DESCRIPTION
1	+26_FAN	26V supply to the fans; routed from 12-position HPCA connector
2	+26_FAN_RTN	26V supply return to the fans; routed from 12-position HPCA connector
3	FAN_ALARM1	Alarm for one of three fans in fan assembly / AIM. Generated by the fan assembly / AIM and sent to the MFRM via the MCPA's RS485 link.
4	FAN_ALARM2	Alarm for one of three fans in fan assembly / AIM. Generated by the fan assembly / AIM and sent to the MFRM via the MCPA's RS485 link.
5	FAN_ALARM3	Alarm for one of three fans in fan assembly / AIM. Generated by the fan assembly / AIM and sent to the MFRM via the MCPA's RS485 link.
6	AUX_ALARM+	Analog voltage signal that is generated from either an external power combiner or an intrusion alarm mechanism, passed to the MFRM through the RS485.
7	AUX_ALARM-	Analog voltage signal that is generated from either an external power combiner or an intrusion alarm mechanism, passed to the MFRM through the RS485.
8	AUX_CTRL1	Contact closure switch on the MCPA but controlled by the MFRM software. Default status is OPEN upon power up and CLOSED on power down conditions.
9	AUX_CTRL2	Contact closure switch on the MCPA but controlled by the MFRM software. Default status is OPEN upon power up and CLOSED on power down conditions.
10	+5V_AIM_RTN	5V supply return for the AIM. Comes from the HPCA via connector P2 and routed through MCPA.
11	+5V_AIM	5V supply for the AIM. Comes from the HPCA via connector P2 and routed through MCPA
12	IIC_CLK+	Differential IIC clock to the fan assembly / AIM
13	IIC_CLK-	Differential IIC clock to the fan assembly / AIM
14	IIC_RX_DATA+	Differential IIC receive data (from fan assembly / AIM)
15	IIC_RX_DATA-	Differential IIC receive data (from fan assembly / AIM)
16	IIC_TX_DATA+	Differential IIC transmit data (to fan assembly / AIM)
17	IIC_TX_DATA-	Differential IIC transmit data (to fan assembly / AIM)
18	FORCE_ON+	Routed directly from MTRM connector; turns on LEDs (in the AIM) during power-up sequence.
19	FORCE_ON-	Routed directly from MTRM connector; turns on LEDs (in the AIM) during power-up sequence.
20	+26V_FAN	26V supply for the fans from (HPCA) connector P2
21	+26V_FAN_RTN	26V supply return for the fans from (HPCA) connector P2
22-26	NC	Not connected

2-9. IIC, RS485, POWER, AND OTHER SIGNALS CONNECTOR P5

The alarms and sensing connections on the amplifier are made through a 18-pin micro-fit connector (figure 2-5) and are listed and described in table 2-5.

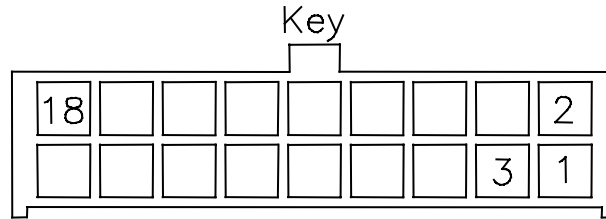

Figure 2-5. IIC, RS485, Power, and Other Signals Connector P5

Table 2-5. IIC, RS485, Power, and Other Signals Connector P5 Definition

PIN	SIGNAL	DESCRIPTION
1	FORCE_ON+	Turns on LEDs (in the AIM) during power up sequence; routed directly from MTRM connector to fan assembly / AIM connector
2	FORCE_ON-	Turns on LEDs (in the AIM) during power up sequence; routed directly from MTRM connector to fan assembly / AIM connector
3	+ALLOW_HPA_ENABLE	Enables MCPA when high. Requires enable command via RS485 and HW_ENABLE high impedance to ground and no shutdown conditions exist.
4	-ALLOW_HPA_ENABLE	Enables MCPA when high. Requires enable command via RS485 and HW_ENABLE high impedance to ground and no shutdown conditions exist.
5	MCPA_TX+	Differential RS485 link to MTRM
6	MCPA_TX-	Differential RS485 link to MTRM
7	MCPA_RX+	Differential RS485 link from MTRM
8	MCPA_RX-	Differential RS485 link from MTRM
9	IIC_CLK+	Differential IIC clock from MTRM
10	IIC_CLK-	Differential IIC clock from MTRM
11	IIC_RX_DATA+	Differential IIC receive data (from MTRM)
12	IIC_RX_DATA-	Differential IIC receive data (from MTRM)
13	IIC_TX_DATA+	Differential IIC transmit data (to MTRM)
14	IIC_TX_DATA-	Differential IIC transmit data (to MTRM)
15	+5V_DC_IN	+5V supply voltage for the IIC circuit on MCPA; not used in any other circuits.
16	+5V_DC_RTN	+5V supply voltage return for the IIC circuit on MCPA; not used in any other circuits.
17	CABLE_DETECT	Cable detect line connected to GPI/O port of MTRM microprocessor. Pulled high via +5V_DC_IN; connected to reset pin on microcontroller to allow MTRM reset if necessary.
18	HW_ENABLE	Hardware enable signal. MCPA enabled when shorted to chassis ground.

OPERATING INSTRUCTIONS

3-1. INTRODUCTION

This section contains operating instructions for the Multicarrier Cellular Amplifier.

3-2. INITIAL START-UP AND OPERATING PROCEDURES

There are no operating controls or indicators on the NTGY81AC amplifier module. To perform the initial start-up, proceed as follows:

1. Double check to ensure that all input and output cables are properly connected.

CAUTION

Before applying power, make sure that the input and output of the amplifier are properly terminated at 50 ohms. Do not operate the amplifier without a load attached. Refer to table 1-1 for input power requirements. Excessive input power may damage the amplifier

NOTE

The output coaxial cable between the amplifier and the antenna must be 50 ohm coaxial cable. Use of any other cable will distort the output.

2. Turn on supply that provides +26 Vdc to the amplifier system.
3. Turn on external exciter/transceiver and apply RF input signals.

PRINCIPLES OF OPERATION

4-1. INTRODUCTION

This section contains a functional description of the multichannel power amplifier (MCPA).

4-2. RF INPUT SIGNAL

The maximum input power should not exceed the limits specified in table 1-1.

4-3. RF OUTPUT LOAD

The load impedance should be as good as possible (1.5:1 or better) in the working band for good power transfer to the load.

4-4. AMPLIFIER FUNCTIONAL DESCRIPTION

The NTGY81AC amplifier (figures 1-1 and 4-1) is a linear, multichannel power amplifier that operates in the 60 MHz frequency band from 1930 MHz to 1990 MHz at an output power of 50 watts. Each amplifier is a self-contained module and is functionally independent of any other amplifier modules in the system. Each amplifier module has an alarm board that monitors the amplifier performance. If a failure or fault occurs in an amplifier module, it is transmitted to the host system via an RS485 interface.

The amplifier is compliant to the requirements of FCC Part 24 with respect to spurious emissions (see table 1-1). Constant gain is maintained by continuously comparing active paths with passive references, and correcting for small variations through the RF feedback controls. All gain variations, for example those due to temperature, are reduced to the passive reference variations. The amplifier module is comprised of:

- An input amplifier
- A predistortion amplifier
- A driver amplifier
- A main amplifier
- A multifunction board

4-4.1. INPUT AMPLIFIER

RF is fed to the input amplifier, which consists of an isolator at the input, bandpass filter, VVAs, and phase shifters for gain control and phase sweeping functions. They are controlled by a microprocessor on the multifunction board. At its output, the input amplifier splits the signal to the predistortion amplifier and carrier cancellation circuits.

4-4.2. PREDISTORTION AMPLIFIER

The predistortion amplifier predistorts the input signal in a way that it linearizes the output of the main amp at 50 watts. It also contains the main loop VVAs and phase shifters. All the predistortion voltages and loop voltages are controlled by a microprocessor.

4-4.3. DRIVER AMPLIFIER

The driver amplifier consists of two stages of class AB amplification which provide approximately 40 dB of gain in the 60 MHz frequency band from 1930 MHz to 1990 MHz. The amplifier operates on +26 Vdc, and a safe bias voltage which is controlled by microprocessors.

4-4.4. MAIN AMPLIFIER

The main amplifier employs two class AB amplification stages for maximum efficiency. It provides approximately 25 dB of gain in the 60 MHz frequency band. The output from the main amplifier is typically 48.6 dBm. The amplifier operates on +26 Vdc, and gate bias voltages controlled by microprocessors.

4-4.5. MULTIFUNCTION BOARD

The multifunction board consists of control and alarm circuits. The MCPA communicates to the host system through the multifunction board which gathers the status information of the amplifier and reports to the host system via the RS485 interface when instructed. It also protects the MCPA from adverse conditions such as overpower, input overdrive, overvoltage, etc. A microprocessor on the multifunction board also controls two loops in the feed-forward system.

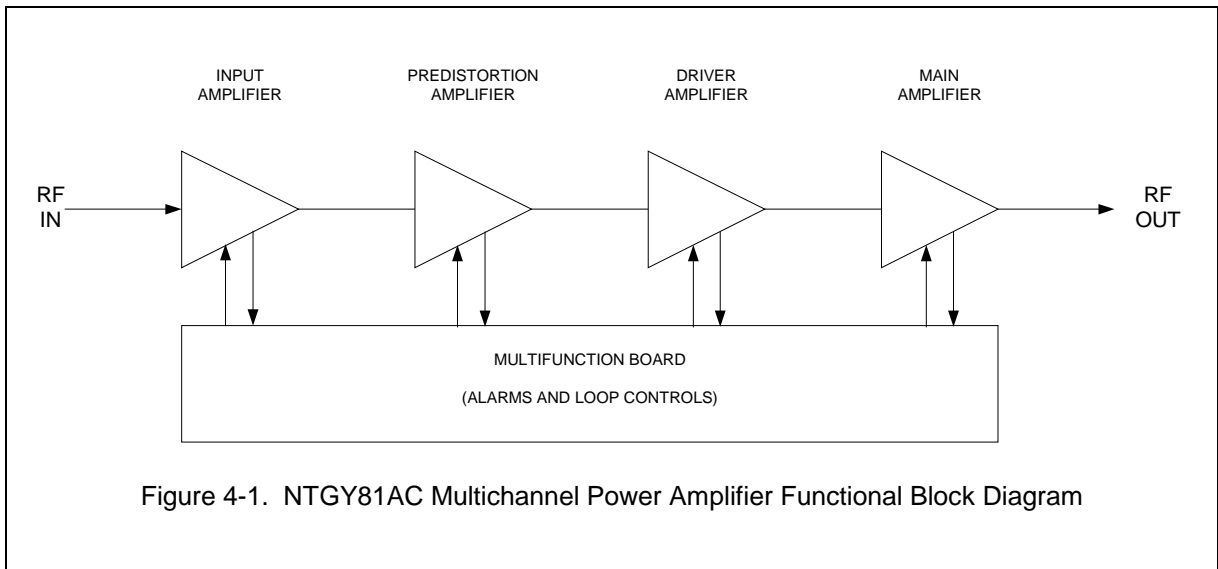

4-5. AMPLIFIER MODULE COOLING

Each amplifier module is contained within a thermally conductive chassis which, when properly mounted on an adequate thermal surface, will provide sufficient cooling to maintain the amplifier within the specified operating temperature range.

4-6. POWER DISTRIBUTION

Primary DC power for the amplifier is provided by the host system. The amplifier generates all the required voltages internally from the main source.

MAINTENANCE

5-1. INTRODUCTION

This section contains periodic maintenance and performance test procedures for the multichannel power amplifier. It also contains a list of test equipment required to perform the identified tasks.

NOTE

Check your sales order and equipment warranty before attempting to service or repair the unit. Do not break the seals on equipment under warranty or the warranty will be null and void. Do not return equipment for warranty or repair service until proper shipping instructions are received from the factory.

5-2. PERIODIC MAINTENANCE

Periodic maintenance requirements are listed in Table 5-1. Table 5-1 also lists the intervals at which the tasks should be performed.

Table 5-1. Periodic Maintenance

TASK	INTERVAL	ACTION
Inspection Cables and Connectors	12 Months	Inspect signal and power cables for frayed insulation. Check RF connectors to be sure that they are tight.
Performance Tests	12 Months	Perform annual test per paragraph 5-5.

5-3. TEST EQUIPMENT REQUIRED FOR TEST

Test equipment required to test the amplifier is listed in Table 5-2. Equivalent test equipment may be substituted for any item, keeping in mind that a thermistor type power meter is required.

NOTE

All RF test equipment must be calibrated to 0.05 dB resolution. Any deviation from the nominal attenuation must be accounted for and factored into all output readings.

Table 5-2. Test Equipment Required

MENCLATURE	MANUFACTURER	MODEL
Signal Generator	Agilent (H.P.)	ESG4433B
30 dB Attenuator, 250 Watt	Tenuline	
Spectrum Analyzer	H.P.	8562E
Coax Directional Coupler	H.P.	778D
Power Meter / Sensor	H.P.	437B / 8481A
Network Analyzer	H.P.	8753D
Current Probe		
Source Diskette	Powerwave	
Driver PA (1930-1990 MHz)	12 dB gain, $P_{1dB} = 29$ dBm (min)	

5-4. PERFORMANCE TEST

Performance testing should be conducted every 12 months to ensure that the amplifier system meets the operational specifications listed in table 5-3. Also verify system performance after any amplifier module is replaced in the field. The test equipment required to perform the testing is listed in table 5-2, and the test setup is shown in figure 5-1.

5-4.1. AMPLIFIER PERFORMANCE TEST.

To perform the test, proceed as follows:

1. Connect test equipment as shown in figure 5-1.

NOTE

Do not apply any RF signals at this time.

AMPLIFIER SPURIOUS EMISSIONS TEST:

2. Load the MFRM waveform on the ESG (signal generator). Apply this signal through a driver amplifier to the MCPA so that the RF signal going into the MCPA is approximately 0 dBm (adjust the input RF signal level to get 47 dBm output power). Measure spurious emissions. Verify that it is within specification.

GAIN TEST:

3. Set input power level to power amplifier at 0 dBm (1932, 1960, and 1987 MHz).
4. Measure the output power in dBm.
5. Subtract input power (in dBm) from output power (in dBm) to get gain.
6. Check the amplifier gain across the band from 1930 MHz to 1990 MHz. Gain should be 47 ± 2 dB. Record test data in table 5-3.

INPUT RETURN LOSS TEST:

7. Read and record the S_{11} return loss measurement on network analyzer. Record test data in table 5-3.

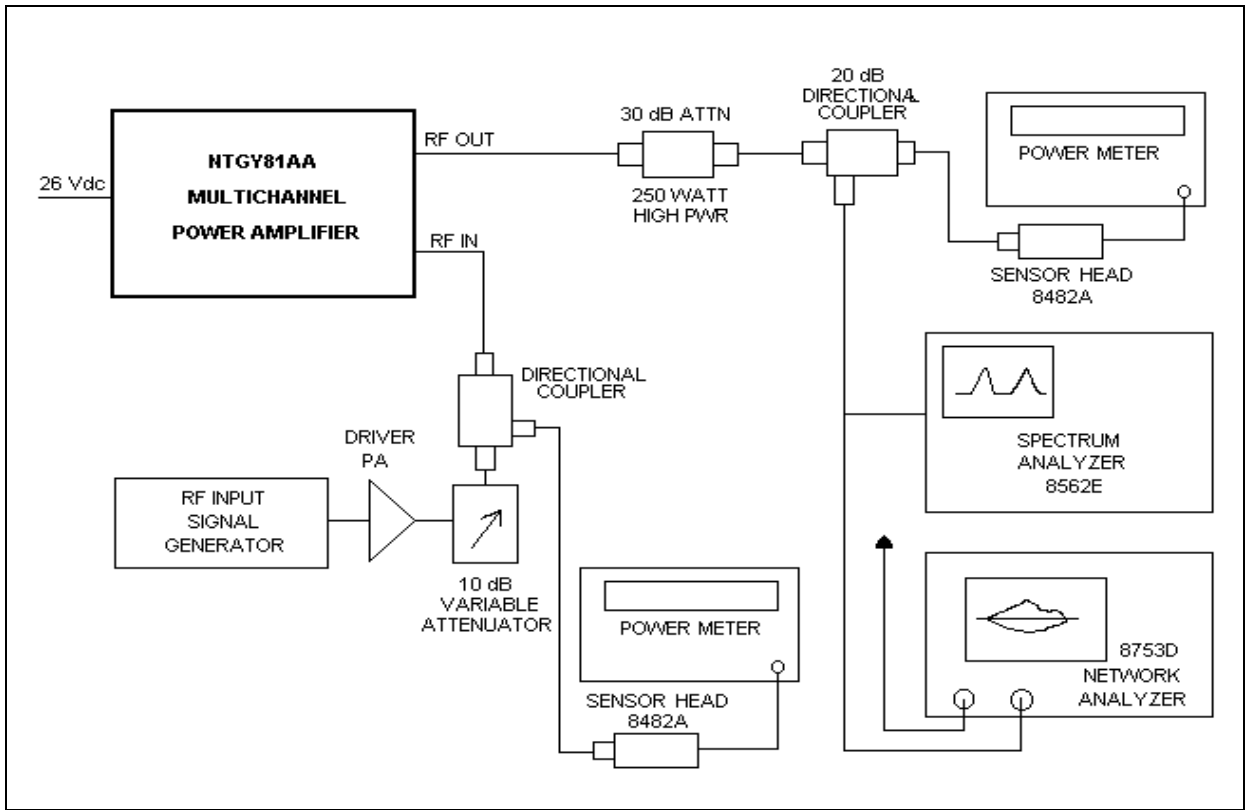

Figure 5-1. NTGY81AC Amplifier Test Setup Diagram

Table 5-3. Multichannel Power Amplifier NTGY81AC Test Data Sheet

Tested By: _____

Serial No: _____

Pass/Fail: _____

Date: _____

50W MCPA Test

Test Conditions: Load and source impedance: **50 ohms**, **VSWR < 1.2:1**

Supply voltage: **+26 Vdc ± 0.4 Vdc** (unless otherwise noted).

Network Analyzer Span: **60 MHz**

Marker #1 = 1930 MHz, #2 = 1960 MHz, #3 = 1990 MHz

TEST	CONDITION	MIN	MAX	FREQUENCY (MHz)		
				1930	1960	1990
1.00	NETWORK ANALYZER					
1.01	Gain	45.0 dB	49.0 dB			
1.02	Gain Flatness	0 dB	0.4 dB/ 1.25 MHz			
1.03	Input Return Loss, worst case In band		-10 dB			
1.04	Output Return Loss, worst case in band		-15 dB			
2.00	CDMA TESTS (Spurious Emissions)					
	3 TONE: W-CDMA @ 50W out					
	RBW= 3KHz; VBW=10KHz					
2.01	Δ @ +2.25 Mhz		-16 dBm/ 1 MHz			
2.02	Δ @ -2.25 Mhz		-16 dBm/ 1 MHz			
2.03	2 nd Harmonic			3860	3920	3980
			-16 dBm/ 1 MHz			
2.04	Pilot			1925	1945	1965
			16 dBm/ 1 MHz			
2.05	Current @ 50 W out		19 A			

5-5. FIELD REPLACEMENT OF THE MODULE

The NTGY81AC multichannel power amplifier module can be replaced in the field on site by a qualified technician with adequate ESD protection and experience maintaining RF power amplifiers and similar equipment.

To replace a power amplifier module, proceed as follows:

1. Turn off 26 Vdc power to that specific module.
2. Disconnect the two RF cables and connectors P1 through P5.
3. Remove 13 screws that secure amplifier module to heat sink.
4. Carefully remove amplifier module from heat sink.
5. Add Thermstrate thermal interface pad to surface of replacement amplifier which mates with heatsink.
6. Install replacement in reverse order of steps 1 through 4 above.

TROUBLESHOOTING

6-1 INTRODUCTION

This section contains a list of problems which users have encountered and a few suggested actions that may correct the problem. If the suggested corrective action does not eliminate the problem, please contact your Powerwave field representative or the factory for further instructions.

NOTE

Check your sales order and equipment warranty before attempting to service or repair the unit. Do not break the seals on equipment under warranty or the warranty will be null and void. Do not return equipment for warranty or repair service until proper shipping instructions are received from the factory.

6-2 TROUBLESHOOTING

Refer to table 6-1 for troubleshooting suggestions.

Table 6-1. Troubleshooting.

SYMPTOM	SUGGESTED ACTION
MCPA Inoperative	1. Check for proper power supply voltage.
MCPA Not Enabled	1. Verify HPA-Allow-Enable line is high.
Alarm Output is (RS 422) High	Verify input RF is within specified power and frequency limits

6-3 RETURN FOR SERVICE PROCEDURES

When returning products to Powerwave, the following procedures will ensure optimum response.

6-3.1 Obtaining an RMA

A Return Material Authorization (RMA) number must be obtained prior to returning equipment to the factory for service. Please contact our Repair Department at (888) 797-9283 or (714) 466-1000 to obtain this number, or FAX your request to (714) 466-5816. Failure to obtain this RMA number may result in delays in receiving repair service.

6-3.2 Repackaging for Shipment

To ensure safe shipment of the amplifier, it is recommended that the package designed for the amplifier be used. The original packaging material is reusable. If it is not available, contact Powerwave's Customer Service Department for packing materials and information.