

PRINCIPLES OF OPERATION

4-1. INTRODUCTION

This section contains a functional description of the multichannel power amplifier (MCPA).

4-2. RF INPUT SIGNAL

The maximum input power should not exceed the limits specified in table 1-1.

4-3. RF OUTPUT LOAD

The load impedance should be as good as possible (1.5:1 or better) in the working band for good power transfer to the load.

4-4. AMPLIFIER FUNCTIONAL DESCRIPTION

The NTGY81AC amplifier (figures 1-1 and 4-1) is a linear, multichannel power amplifier that operates in the 60 MHz frequency band from 1930 MHz to 1990 MHz at an output power of 50 watts. Each amplifier is a self-contained module and is functionally independent of any other amplifier modules in the system. Each amplifier module has an alarm board that monitors the amplifier performance. If a failure or fault occurs in an amplifier module, it is transmitted to the host system via an RS485 interface.

The amplifier is compliant to the requirements of FCC Part 24 with respect to spurious emissions (see table 1-1). Constant gain is maintained by continuously comparing active paths with passive references, and correcting for small variations through the RF feedback controls. All gain variations, for example those due to temperature, are reduced to the passive reference variations. The amplifier module is comprised of:

- An input amplifier
- A predistortion amplifier
- A driver amplifier
- A main amplifier
- A multifunction board

4-4.1. INPUT AMPLIFIER

RF is fed to the input amplifier, which consists of an isolator at the input, bandpass filter, VVAs, and phase shifters for gain control and phase sweeping functions. They are controlled by a microprocessor on the multifunction board. At its output, the input amplifier splits the signal to the predistortion amplifier and carrier cancellation circuits.

4-4.2. PREDISTORTION AMPLIFIER

The predistortion amplifier predistorts the input signal in a way that it linearizes the output of the main amp at 50 watts. It also contains the main loop VVAs and phase shifters. All the predistortion voltages and loop voltages are controlled by a microprocessor.

4-4.3. DRIVER AMPLIFIER

The driver amplifier consists of two stages of class AB amplification which provide approximately 40 dB of gain in the 60 MHz frequency band from 1930 MHz to 1990 MHz. The amplifier operates on +26 Vdc, and a safe bias voltage which is controlled by microprocessors.

4-4.4. MAIN AMPLIFIER

The main amplifier employs two class AB amplification stages for maximum efficiency. It provides approximately 25 dB of gain in the 60 MHz frequency band. The output from the main amplifier is typically 48.6 dBm. The amplifier operates on +26 Vdc, and gate bias voltages controlled by microprocessors.

4-4.5. MULTIFUNCTION BOARD

The multifunction board consists of control and alarm circuits. The MCPA communicates to the host system through the multifunction board which gathers the status information of the amplifier and reports to the host system via the RS485 interface when instructed. It also protects the MCPA from adverse conditions such as overpower, input overdrive, overvoltage, etc. A microprocessor on the multifunction board also controls two loops in the feed-forward system.

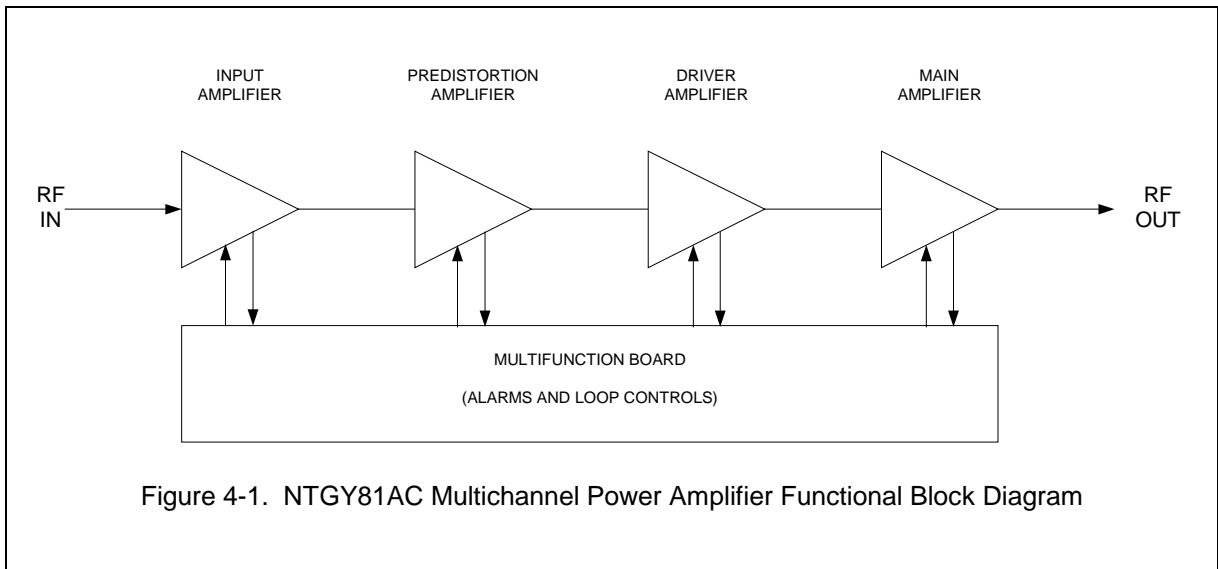

4-5. AMPLIFIER MODULE COOLING

Each amplifier module is contained within a thermally conductive chassis which, when properly mounted on an adequate thermal surface, will provide sufficient cooling to maintain the amplifier within the specified operating temperature range.

4-6. POWER DISTRIBUTION

Primary DC power for the amplifier is provided by the host system. The amplifier generates all the required voltages internally from the main source.