

# Section 5 Maintenance

## 5-1 Introduction

This section contains periodic maintenance and performance test procedures for the Multicarrier Cellular Amplifier. It also contains a list of test equipment required to perform the identified tasks.

**NOTE**

Check your sales order and equipment warranty before attempting to service or repair the unit. Do not break the seals on equipment under warranty or the warranty will be null and void. Do not return equipment for warranty or repair service until proper shipping instructions are received from the factory.

## 5-2 Periodic Maintenance

Periodic maintenance requirements are listed in table 5-1. Table 5-1 also lists the intervals at which the tasks should be performed.

**WARNING**

Wear proper eye protection to avoid eye injury when using compressed air.

**Table 5-1 Periodic Maintenance**

Task	Interval	Action
<b>Cleaning</b> Air Vents	30 Days	Inspect and clean per paragraph 5-4
<b>Inspection</b> Cables and Connectors	12 Months	Inspect signal and power cables for frayed insulation. Check RF connectors to be sure that they are tight.
<b>Performance Tests</b>	12 Months	Perform annual test per paragraph 5-5.

## 5-3 Test Equipment Required For Test

Test equipment required to test the amplifier system is listed in table 5-2. Equivalent test equipment may be substituted for any item, keeping in mind that a thermistor type power meter is required.

**NOTE**

All RF test equipment must be calibrated to 0.05 dB resolution. Any deviation from the nominal attenuation must be accounted for and factored into all output readings.

**Table 5-2 Test Equipment Required**

Nomenclature	Manufacturer	Model
Signal Generator	RDL	IMD-801D-03A
30 dB Attenuator, 500 Watt	Weinschel Corp.	53-30-34
20 dB Attenuator, 20 Watt (2 each)	Tenuline	
Spectrum Analyzer	H.P.	8560E
Coax Directional Coupler	H.P.	778D
Power Meter/Sensor	H.P.	437B/8481A
Network Analyzer	H.P.	8753C
Current Probe		

## 5-4 Cleaning Air Inlets/Outlets

The air inlets and outlets should be cleaned every 30 days. If the equipment is operated in a severe dust environment, they should be cleaned more often as necessary. Turn off DC power source before removing fans. If dust and dirt are allowed to accumulate, the cooling efficiency may be diminished. Using either compressed air or a brush with soft bristles, loosen and remove accumulated dust and dirt from the air inlet panels.

## 5-5 Performance Test

Performance testing should be conducted every 12 months to ensure that the amplifier system meets the operational specifications listed in table 5-3. Also verify system performance after any amplifier module is replaced in the field. The test equipment required to perform the testing is listed in table 5-2, and the test setup is shown in figure 5-1.

### NOTE

The frequencies used in this test are typical for an amplifier with a 18 MHz band from 851 MHz to 869 MHz. Select evenly spaced F1, F2, F3, and F4 frequencies that cover the instantaneous bandwidth of your system.

### 5-5.1 Amplifier System Performance Test

This test is applicable to the G3S-800-140-031 amplifier modules. To perform the test, proceed as follows:

1. Connect test equipment to the amplifier as shown in figure 5-1.

### NOTE

Do not apply any RF signals at this time.

Turn on signal generator and set frequency F1 to 854 MHz, F2 to 857 MHz, F3 to 863 MHz, and F4 to 866 MHz. Adjust each signal generator output so that the sum power output from all four signal generators equals -6 dBm at the input.

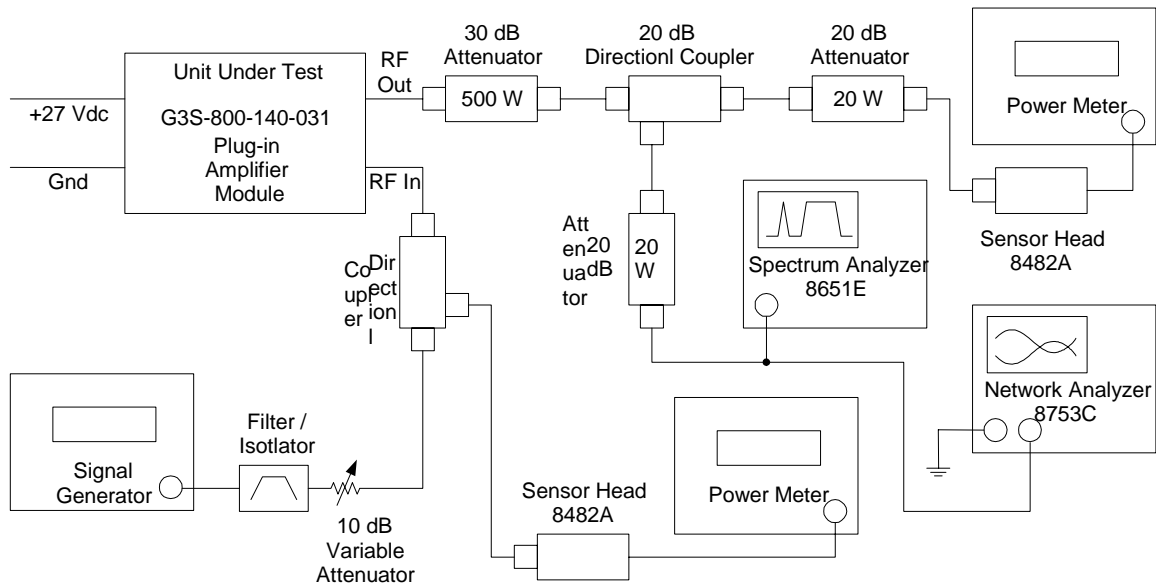

Figure 5-1 Amplifier System Test Setup Diagram

#### 5-5.1.1 Amplifier IMD Test And Current Test

2. Adjust attenuator for an input signal at -10 dBm. Turn on the amplifier by setting RF ON switch of amplifier. Adjust variable attenuator to set amplifier power output on power meter to 140 watts. Measure IMD on spectrum analyzer. IMD should be -60 dBc max. Record test data in table 5-3. Set RF ON switch to OFF.
3. With the amplifier module set at 140 watts power output, use the current probe (magnetic field type) and measure the dc current flow from the +27 Vdc power source. Current should be 70 amps maximum. Record test data in table 5-3.

#### 5-5.1.2 Gain Test

4. Disconnect spectrum analyzer from test setup, and connect the network analyzer.
5. Set network analyzer as follows:
  - Power output to -10 dBm.
  - Frequency start to 869 MHz.
  - Frequency stop to 894 MHz.
  - Normalize the network analyzer for gain and return loss.
6. Check the gain across the band from 869 MHz to 894 MHz. Gain should be between 58 dB. Record test data in table 5-3.

#### 5-5.1.3 Harmonics Test

7. With the power set at 140 watts power output, use the spectrum analyzer and check the frequency band from 851 MHz to 869 MHz for harmonics. Harmonics should be 5 dBm maximum. Record test data in table 5-3.

#### 5-5.1.4 Spurious Test

8. With the power amplifier set at 140 watts power output, use the spectrum analyzer and check the frequency band from 851 MHz to 869 MHz for spurious signals. Spurious signals should be -60 dBc maximum. Record test data in table 5-3.

#### 5-5.1.5 Input Return Loss Test

9. Reset and turn on amplifier module. Read and record the  $S_{11}$  return loss measurement on network analyzer. Input return loss should be -16 dB maximum. Record test data in table 5-3.

**Table 5-3 Multicarrier Cellular Amplifier Test Data Sheet**

DATE \_\_\_\_\_

AMPLIFIER S/N \_\_\_\_\_

**TEST CONDITIONS:**

Load and Source Impedance: 50 Ohms

VSWR: < 1.2:1

Supply Voltage: +27 Vdc ±1.0 Vdc

TEST	SPECIFICATION	MIN	MAX	DATA
4-TONE IMD	Vcc = 27 Vdc PO = 140 W Freq.: 853, 857, 863, and 866 MHz		-60 dBc	
RF Gain	Vcc = 27 Vdc PO = 140 W Freq. = 860 MHz	57.5 dB	58.5 dB	
Gain Flatness	Vcc = 27 Vdc ±1 Vdc PO = 140 W 851-869 MHz Band	-0.5 dB	+0.5 dB	
Harmonics	Vcc = 27 Vdc PO = 140 W 851-869 MHz Band		5 dBm	
Spurious	Vcc = 27 Vdc PO = 140 W 851-869 MHz Band		-60 dBc	
Input Return Loss	Vcc = 27 Vdc PO = 140 W 851-869 MHz Band		-16 dB	
DC Power	Vcc = 27 Vdc PO = 140 W 4 Tones		70 Amps	

PASS \_\_\_\_\_

FAIL \_\_\_\_\_

Tested by \_\_\_\_\_

## 5-6 Field Replaceable Parts And Modules

The following parts and modules can be replaced in the field on site by a qualified technician with experience maintaining RF power amplifiers and similar equipment:

1. G3S-800-140-031 power amplifier modules
2. Cooling fans

### 5-6.1 G3S-800-140-031 Power Amplifier Module

To replace a power amplifier module, proceed as follows:

1. Set both the RF ON On/Off/Reset switch and the power ON/OFF switch on the front panel of the amplifier module to OFF.
2. Loosen two screws that secure amplifier module to subrack.
3. Use handle on front of module, and with a steady even pressure, pull module out of subrack.

#### CAUTION

When removing the amplifier from the subrack, it is very important to support the amplifier such that the rear of the module does not suddenly drop when it disengages from the track. A drop such as this could damage the module.

### 5-6.2 Cooling Fans

To replace a cooling fan, proceed as follows:

1. Remove amplifier module from subrack; see paragraph 5-6.1 preceding.
2. Loosen four snap fasteners that secure fan to amplifier module. Disconnect fan power connector from amplifier module.

Install replacement in reverse order of steps 1 and 2 above.