

## ***Section 4 Principles of Operation***

### ***4-1 Introduction***

This section contains a functional description of the Multicarrier Cellular Amplifier.

### ***4-2 RF Input Signal***

The maximum input power for all carrier frequencies should not exceed the limits specified in table 1-2. For proper amplifier loop balance, the out of band components of the input signals should not exceed -40 dBc. The input VSWR should be 2:1 maximum (or better).

### ***4-3 RF Output Load***

The load impedance should be as good as possible (1.5:1 or better) in the working band for good power transfer to the load. If the amplifier is operated into a filter, it will maintain its distortion characteristics outside the signal band even if the VSWR is infinite, provided the reflected power does not exceed one watt. A parasitic signal of less than one watt incident on the output will not cause distortion at a higher level than the normal forward distortion (i.e. -60 dBc).

### ***4-4 G3S-800-140 Amplifier Module***

The G3S-800-140 amplifier is a linear, feed-forward power amplifier that operates in the 25 MHz frequency band from 869 MHz to 894 MHz. The amplifier modules are designed for parallel operation to achieve high peak power output, and for redundancy in unmanned remote locations. The amplifier module, figure 4-1, has an average output of 140 watts power (1400 watts peak power) with intermodulation products suppressed to better than -60 dBc below carrier levels. The amplifier provides an amplified output signal with constant gain and phase by adding approximately 30 dB of distortion cancellation on the output signal. Constant gain and phase is maintained by continuously comparing active paths with passive references, and correcting for small variations through the RF feedback controls. All gain and phase variations, for example those due to temperature, are reduced to the passive reference variations. Each amplifier module has an alarm and display board that monitors the amplifier performance. If a failure or fault occurs in an amplifier module, it is displayed on the individual amplifier front panel.

The amplifier module is comprised of:

#### Pre-amplifiers

- Main amplifier

- Error amplifier

- Two feed-forward loops with phase-shift and gain controls

- DC/DC power regulator

- Alarm monitoring, control and display panel

The main amplifier employs class AB amplification for maximum efficiency. The error amplifier and feed forward loops are employed to correct signal nonlinearities introduced by the class AB main amplifier. The error amplifier operates in class AB mode. The RF input signals are amplified by a preamp and coupled to an attenuator and phase shifter in the first feed-forward loop. The main signal is phase shifted by 180 degrees and amplified in the premain amplifier. The output from the premain amplifier is fed to the class AB main amplifier. The output from the main amplifier is typically 220 watts. The signal is output to several couplers and a delay line.

The signal output from the main amplifier is sampled using a coupler, and the sample signal is combined with the main input signal and input to the second feed-forward loop. The error signal is

attenuated, phase shifted 180 degrees, then fed to the error amplifier where it is amplified to a level identical to the sampled output from the main amplifier. The output from the error amplifier is then coupled back and added to the output from the main amplifier. The control loops continuously make adjustments to cancel out any distortion in the final output signals.

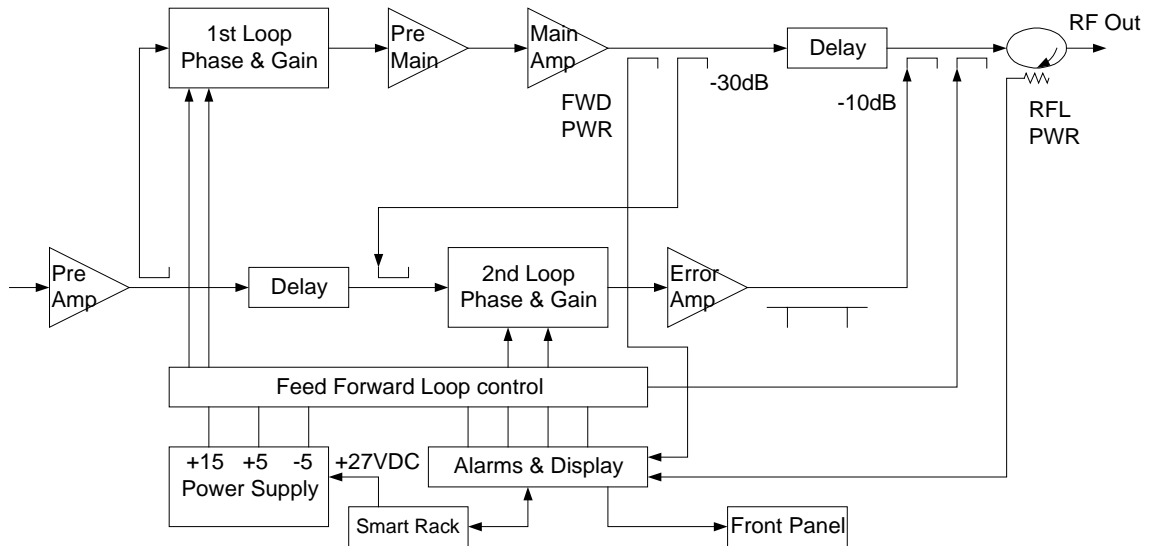

Figure 4-1 G3S-800-140 Power Amplifier Module Functional Block Diagram

The 2nd loop control section obtains a sample of the distortion added to the output signals by the main amplifiers, phase shifts the signals by 180 degrees, then feeds it to the error amplifier. There it is amplified to the same power level as the input sample and coupled on to the main output signal. The final output is monitored by the 2nd loop and adjusted to ensure that the signal distortion and IMD on the final output is canceled out.

#### 4-4.1 Main Amplifier

The input and output of the amplifier employ two-stage, class AB amplifiers which provide approximately 32 dB of gain in the 25 MHz frequency band from 869 to 894 MHz. The amplifier operates on +27 Vdc, and a bias voltage of +5 Vdc, and is mounted directly on a heat sink which is temperature monitored by a thermostat. If the heat sink temperature exceeds 85 °C, the thermostat opens and a high temperature fault occurs. The alarm logic controls the +5 Vdc bias voltage which shuts down the amplifier.

#### 4-4.2 Error Amplifier

The main function of the error amplifier is to sample and amplify the signal distortion level generated by the main amplifier, to a level that cancels out the distortion and IMD when the error signal is coupled onto the main signal at the amplifier output. The error amplifier is a balanced multi-stage, class AB amplifier, has 51 dB of gain, and produces up to an 80-watt output. The amplifier operates on 27 Vdc and a bias voltage of +5 Vdc, and is mounted directly on a heat sink.

#### 4-4.3 Amplifier Monitoring

In the main and error amplifier modules, all normal variations are automatically compensated for by the feedforward loop control. However, when large variations occur beyond the adjustment range of the loop control, a loop fault will occur. The alarms are displayed on the front panel indicators and output via a 21-pin connector on the rear of the module to the subrack summary board for subsequent remote monitoring via the ALARMS connector. Refer to paragraph 2-5 as well as figure 2-2 and table 2-2 for a description of the ALARMS connector.

#### ***4-4.4 Amplifier Module Cooling***

Although each amplifier module contains its own heat sink, it is cooled with forced air. Four fans are used for forced air cooling and redundancy. The fans, located on the front and rear of the amplifier module, draw air in through the front of the amplifier and exhaust hot air out the back of the module. The fans are field replaceable.

#### ***4-5 Power Distribution***

Primary DC power for the system is provided by the host system to the MCR30830-1-3 Series subrack. The subrack supplies each amplifier module with +27 Vdc directly and via the RF power splitter/combiner. The amplifier module has a DC/DC converter that converts the +27 Vdc to +15 Vdc, +5 Vdc and -5 Vdc.

#### ***4-6 Intermodulation***

The G3S-800-140 amplifier is designed to deliver a 140-watt composite average power, multicarrier signal, occupying a bandwidth less than or equal to 25 MHz, in the bandwidth from 869 to 894 MHz. The maximum average power for linear operation, and thus the amplifier efficiency, will depend on the type of signal amplified.

##### ***4-6.1 Two Tone Intermodulation***

When measured with two equal CW tones spaced anywhere from 30 kHz to 20 MHz apart, and at any power level up to the average power, the third order intermodulation products will be below -60 dBc

##### ***4-6.2 Multitone Intermodulation***

Adding more tones to the signal will lower individual intermodulation products. If the frequencies are not equally spaced, the level of intermodulation products gets very low. When the frequencies are equally spaced, those products fall on top of each other on the same frequency grid. The average power of all intermodulation beats falling on the same frequency is called the composite intermodulation; it is -60 dBc or better.

#### ***4-7 Alarms***

The presence of several plug-in amplifier alarms can be detected at the DC and logic connector on the amplifier rear panel. Refer to table 2-1 and figure 2-2 for a description of the connector.