



FCC CFR47 PART 90 CERTIFICATION

TEST REPORT

FOR

SINGLE CHANNEL 100W AMPLIFIERS

MODEL: K-10

FCC ID: E675JS0032

REPORT NUMBER: 98E7654

ISSUE DATE: AUGUST 7, 1998

Prepared for
POWERWAVE TECHNOLOGIES, INC.
2026 MCGAW AVENUE
IRVINE, CA 92614 USA

Prepared by
COMPLIANCE CERTIFICATION SERVICES, INC.
1366 BORDEAUX DRIVE
SUNNYVALE, CA 94089, USA
TEL: (408) 752-8166
FAX: (408) 752-8168

NVLAP[®]
LAB CODE: 200065-0

TABLE OF CONTENTS

PAGE

1. FCC CERTIFICATION INFORMATION.....1

2. VERIFICATION OF COMPLIANCE3

3. TEST FACILITY4

4. ACCREDITATION AND LISTING.....4

5. MEASUREMENT INSTRUMENTATION.....4

6. MEASURING INSTRUMENT CALIBRATION.....4

7. UNITS OF MEASUREMENT4

8. CLASSIFICATION OF DIGITAL DEVICE5

9. RADIATED EMISSION LIMITS.....6

10. RADIATED EMISSION TEST PROCEDURE.....7

11. CONDUCTED EMISSION LIMITS7

12. AMBIENT CONDITIONS.....8

13. EQUIPMENT MODIFICATIONS.....8

14. TEST EQUIPMENT LIST9

15. EUT SETUP PHOTOS.....10

17. EXTERNAL I/O CABLE CONSTRUCTION DESCRIPTION14

18. CONFIGURATION BLOCK DIAGRAM.....15

19. FCC PART 2 CERTIFICATION TEST RESULTS:16

 SECTION 2.1046 RF POWER OUTPUT 16

 SECTION 2.1047 MODULATION CHARACTERISTICS 17

 SECTION 2.1049 OCCUPIED BANDWIDTH 17

 SECTION 2.1051 SPURIOUS EMISSION AT ANTENNA TERMINALS 19

 SECTION 2.1053 FIELD STRENGTH OF SPURIOUS RADIATION 21

 SECTION 2.1055 FREQUENCT STABILITY..... 25

ATTACHMENT

1. EUT PHOTOGRAPHS
2. INSTALLATION & SERVICE MANUAL
3. ADDENUM 1 SCHEMATIC & PARTS LISTS
4. PROPOSED FCC ID LABEL FORMAT

1. FCC CERTIFICATION INFORMATION

The following information is in accordance with FCC Rules, 47CFR Part2, Sections 2.1033 – 2.1057.

Section 2.1033

- (1) Applicant/Manufacturer: POWERWAVE TECHNOLOGIES, INC.
2026 McGAW AVENUE
IRVINE, CA 92614

Contact person: JEFF DALE

Telephone number: (949)809-1466
- (2) FCC ID: E675JS0032, Model: K-10
- (3) Instructions/Installation Manual :Refer to Attachment: Installation and Service manual.
- (4) Type of Emissions: F3E
- (5) Frequency Range: Power Amplifier: 850 – 870MHz
- (6) Maximum Power Rating: 100 Watts
- (7) Maximum power rating as defined in Section 90.635(b): < 500Watts.
- (8) Applied voltage and currents into the final transistor elements:

Refer to Attachment: Schematics and Parts list. Confidentiality is requested for these items.
- (9) Tune-up Procedure: Refer to Attachment: Installation and Service manual.
- (10) Function of Each Active Device

<u>ITEM</u>	<u>P-WAVE PART NO.</u>	<u>VENDOR</u>	<u>VENDOR PART NO.</u>	<u>QTY</u>	<u>PART NAME</u>
1	925-00017-002	MINI CKTS	ERA-2SM	1	MIC AMP.
2	925-00035-001	MINI CKTS	ERA-5SM	1	MIC AMP
3	924-00028-001	MOTOROLA	MRF184	2	TRANSISTOR
4	924-00019-001	MOTOROLA	MRF182	1	TRANSISTOR

Complete Circuit Diagrams and Functional Diagram

Refer Attachment: Schematics and Parts list. Confidentiality is requested for these items.

Means for Frequency Stabilization: Not Applicable. Eut is a power amplifier

Means for Limiting Modulation: Not Applicable. Eut is a power amplifier

Means for Limiting Power: Not Applicable.

Means for Attenuating Higher Audio Frequencies:

7-pole low-pass filters at the output to suppress spurious emission.

(11) FCC ID label format: A drawing of the equipment identification nameplate appears under Attachment: PROPOSED FCC ID LABEL FORMAT.

(12) Photograph: Photographs of the equipment, internal and external views, are found in the Attachment: Eut Photographs .

(13) Description of Digital Modulation Techniques: Not Applicable.

Standard Test Condition

The power amplifier was tested under the following conditions.

AC Supply Voltage: 120Vac, 60Hz

DC Supply Voltage: 28Vdc

The amplifier was aligned and tuned up according to manufacturer's alignment procedure, prior to testing. All data presented represents the worst case parameter being measured. Normal operation is from 25 - 29 Vdc sources.

2. VERIFICATION OF COMPLIANCE

DESCRIPTION OF PRODUCT:

The K10 amplifier is designed for trunking and conventional repeater applications requiring high duty cycle. The K10 amplifier operates from RF power sources of 250 milliwatts up to 25 watts. The amplifier consists of an input attenuator, a predriver amplifier, a microprocessor control circuit, and two stages of amplification followed by a 7-pole distributed low-pass filter and associated control circuitry. The K10 amplifier has a microprocessor control board that maintains a constant output power under varying signal input and output load conditions. A system functional block diagram of the Model K10 amplifier is contained in section 4 of this manual.

The K10 amplifier (see block diagram figure 4-2 in manual) is a linear, single channel amplifier that operates in the frequency band from 850 MHz to 870 MHz. The amplifier specifications are listed in the table 1-2 of manual. Each amplifier is a self-contained plug-in module and is functionally independent of other amplifier modules. The amplifier modules are designed for parallel operation to achieve high peak power output, and for redundancy in unmanned remote locations. Each amplifier in the system can simultaneously transmit carrier frequencies, at an average total power output of 100 Watts.

TYPE OF EQUIPMENT:	SINGLE CHANNEL 100W AMPLIFIER
MEASUREMENT DISTANCE:	3 METER
TECHNICAL LIMIT:	FCC 90.210, 90.691
FCC RULES:	PART 2, PART 15, PART 90
EQUIPMENT AUTHORIZATION PROCEDURE	TYPE ACCEPTANCE
MODIFICATIONS MADE ON EUT	<input checked="" type="checkbox"/> YES (REFER TO PAGE 9) <input type="checkbox"/> NO

The above equipment was tested by Compliance Certification Services for compliance with the requirements set forth in the FCC CFR 47, PART 15 AND 90. The results of testing in this report apply to the product/system, which was tested only. Other similar equipment will not necessarily produce the same results due to production tolerance and measurement uncertainties.

Approved By

MIKE C.I. KUO / VICE - PRESIDENT
 COMPLIANCE CERTIFICATION SERVICES

3. TEST FACILITY

The open area test sites and conducted measurement facilities used to collect the radiated data are located at 561F Monterey Road, Morgan Hill, California, USA. The sites are constructed in conformance with the requirements of ANSI C63.7, ANSI C63.4 and CISPR Publication 22.

4. ACCREDITATION AND LISTING

The test facilities used to perform radiated and conducted emissions tests are accredited by National Voluntary Laboratory Accreditation Program for the specific scope of accreditation under Lab Code:200065-0 to perform Electromagnetic Interference tests according to FCC PART 15 AND CISPR 22 requirements. No part of this report may be used to claim or imply product endorsement by NVLAP or any agency of the US Government. In addition, the test facilities are listed with Federal Communications Commission (reference no: 31040/SIT (1300B3) and 31040/SIT(1300F2))

5. MEASUREMENT INSTRUMENTATION

Radiated emissions were measured with one or more of the following types of linearly polarized antennas: tuned dipole, biconical, log periodic, BI-log, ridged waveguide, and liner horn. EMI receivers were used for line conducted readings, spectrum analyzers with pre-selectors and quasi-peak detectors were used to perform radiated measurements. Receiving equipment (i.e., receiver, analyzer, quasi-peak adapter, pre-selector) and LISNs conform to CISPR specification for "Radio Interference Measuring Apparatus and Measurement Methods," Publication 16.

Calibrated wideband preamplifiers, coaxial cables, and coaxial attenuators are also used for making measurements.

6. MEASURING INSTRUMENT CALIBRATION

The measuring equipment, which was utilized in performing the tests documented herein, has been calibrated in accordance with the manufacturer's recommendations for utilizing calibration equipment, which is traceable to recognized national standards.

7. UNITS OF MEASUREMENT

Measurements of radiated interference are reported in terms of dB(uV/m) at a specified distance. The indicated readings on the spectrum analyzer were converted to dB(uV/m) by

use of appropriate conversion factors. Measurements of conducted interference are reported in terms of dB(uV).

The field strength is calculated by adding the Antenna Factor and Cable Factors, then by subtracting the Amplifier Gain from the measured reading. The basic equation with a sample calculation is as follows:

$$FS = RA + AF + CF - AG$$

Where FS = Field Strength

RA = Receiver Amplitude

AF = Antenna Factor

CF = Cable Attenuation Factor

AG = Amplifier Gain

Assume a receiver reading of 52.5 dBuV is obtained. The Antenna Factor of 7.4dB/m and a Cable Factor of 1.1dB is added. The Amplifier Gain of 29 dB is subtracted, giving a field strength of 32 dBuV/m. The 32 dBuV/m value was mathematically converted to its corresponding level in uV/m.

$$FS = 52.5 + 7.4 + 1.1 - 29 = 32 \text{ dBuV/m}$$

$$\text{Level in uV/m} = \text{Common Antilogarithm} [(32 \text{ dBuV/m})/20] = 39.8 \text{ uV/m}$$

8. CLASSIFICATION OF DIGITAL DEVICE

Class A includes digital devices that are marketed for use in commercial, industrial or business environments, excluding devices which are marketed for use by the general public or are intended to be used in the home.

Class B includes digital devices that are marketed for use in residential environments, notwithstanding use in commercial, business and industrial environments.

Note: The responsible party may also qualify a device intended to be marketed in a commercial, business or industrial environment as Class B device, and in fact is encouraged to do so provided the device complies with the technical specifications for a Class B digital device. In the event that a particular type of device has been found to repeatedly cause harmful interference to radio communications, the Commission may classify such a digital device as a Class B digital device, regardless of its intended use.

9. RADIATED EMISSION LIMITS**FCC PART 15 CLASS A**

MEASURING DISTANCE OF 10 METER		
FREQUENCY RANGE (MHz)	FIELD STRENGTH (Microvolts/m)	FIELD STRENGTH (dBuV/m)
30-88	90	39.1
88-216	150	43.5
216-960	210	46.4
Above 960	300	49.5

FCC PART 15 CLASS B

MEASURING DISTANCE OF 3 METER		
FREQUENCY RANGE (MHz)	FIELD STRENGTH (Microvolts/m)	FIELD STRENGTH (dBuV/m)
30-88	100	40
88-216	150	43.5
216-960	200	46
Above 960	500	54

**FCC RADIATED EMISSION ALTERNATIVE METHOD
(CISPR 22/EN55022)**

Limits for radiated disturbance of Class A ITE at
measuring distance of 10 m

Frequency range MHz	Quasi-peak limits dB(uV/m)
30 to 230	40
230 to 1000	47
NOTES	
1. The lower limit shall apply at the transition frequency.	
2. Additional provisions may be required for cases where interference occurs.	

Limits for radiated disturbance of Class B ITE at
Measuring distance of 10 m

Frequency range MHz	Quasi-peak limits dB(uV/m)
30 to 230	30
230 to 1000	37
NOTES	
1. The lower limit shall apply at the transition frequency.	
2. Additional provisions may be required for cases where interference occurs.	

10. RADIATED EMISSION TEST PROCEDURE

The EUT and all other support equipment are placed on a wooden table 80-cm above the ground screen. Antenna to EUT distance is 3 meters . During the test, the table is rotated 360 degrees to maximize emissions and the antenna is positioned from 1 to 4 meters above the ground screen to further maximize emissions. The antenna is polarized in both vertical and horizontal positions.

EUT test configuration is according to Section 8 of ANSI C63.4/1992.

Monitor the frequency range of interest at a fixed antenna height and EUT azimuth. Frequency span should be small enough to easily differentiate between broadcast stations and intermittent ambients. Rotate EUT 360 degrees to maximize emissions received from EUT. If emission increases by more than 1 dB, or if another emission appears that is greater by 1 dB, return to azimuth where maximum occurred and perform additional cable manipulation to further maximize received emission.

Move antenna up and down to further maximize suspected highest amplitude signal. If emission increased by 1 dB or more, or if another emission appears that is greater by 1dB or more, return to antenna height where maximum signal was observed and manipulate cables to produce highest emissions, noting frequency and amplitude.

11. CONDUCTED EMISSION LIMITS

FCC CLASS A

FREQUENCY RANGE	FIELD STRENGTH (Microvolts)	FIELD STRENGTH (dBuV)/QP
450kHz-1.705MHz	1000	60
1.705MHz - 30MHz	3000	69.54

FCC CLASS B

FREQUENCY RANGE	FIELD STRENGTH (Microvolts)	FIELD STRENGTH (dBuV)/QP
450kHz-30MHz	250	48

FCC CONDUCTED EMISSION ALTERNATIVE METHOD (CISPR 22/EN55022)

Limits for conducted disturbance at the mains ports of
 Class A ITE

Frequency range MHz	Limits dB(uV)	
	Quasi-peak	Average
0.15 to 0.50	79	66
0.5 to 30	73	60

Note- The lower limit shall apply at the transition frequency.

Limits of Conducted disturbance at the mains ports
 of Class B ITE

Frequency range MHz	Limits dB(uV)	
	Quasi-peak	Average
0.15 to 0.50	66 to 56	56 to 46
0.50 to 5	56	46
5 to 30	60	50

Note
 1.The lower limit shall apply at the transition frequencies
 2.The limit decreases linearly with the logarithm of the frequency in the range 0.15 MHz to 0.50 MHz.

12. AMBIENT CONDITIONS

The ambient conditions at the time of final tests were as follows:

	Radiated Emission	Conducted Emission
Temperature	17° C	21° C
Humidity	81%	62%

13. EQUIPMENT MODIFICATIONS

The following modifications were made to Eut to be in compliance with FCC limits.

1. Added finger stocks at the top, sides and in between of amplifier chassis, so better ground contact is made with chassis.
2. Added gasket to bottom and top of amplifier chassis so better ground contact is made with bottom and top side of cover.
3. Added copper tape to the front of amplifier chassis were front LED's panel is located, RF was leaking trough the small cracks.

14. TEST EQUIPMENT LIST

Equipment	Manufacturer	Model No.	Serial No.	Site	Cal Date	Due Date
Spectrum Analyzer	H.P.	8566	3710A00205	A	05/98	05/99
Bilog Antenna	CHASE	CBL6112	2049	A	05/98	05/99
Horn Antenna	EMCO	3115	9001-3245	A	12/97	12/00
Pre-Amp	H.P.(P2)	8447D	2944A06550	A	09/98	09/99
Pre-Amp	H.P. (1-26.5GHz)	8449B	3008A00369	A	04/98	04/99

SUPPORT EQUIPMENT

Device Type	Manufacturer	Model Number	Serial No.	FCC ID / DoC
SIGNAL GENERATOR	HP	8648B	002557	N/A
POWER METER	HP	6269B	618219	N/A
HIGH POWER ATTENUATOR	BIRD ELECTRIC	8325	4800	N/A
DIRECTIONAL BRIDGE	H.P.	86205A	3140A01658	N/A
BOOSTER AMP	HP	E3611A	003191	N/A
DC POWER SUPPLY	H.P.	6269B	2436A-11867	N/A

15. EUT SETUP PHOTOS







16. TEST RESULT SUMMARY for part 15.

FCC PART 15 Radiated Emission Test was conducted by operating the configuration as indicated below.

K-10							
OATS No: A / 3 meter		Data Report No. 980807A1		Date 8/7/98		Tested By: JUAN MARTINEZ	
Six Highest Radiated Emission Readings							
Frequency Range Investigated				30 MHz TO 1000 MHz			
Freq. (MHz)	Meter Reading (dBuV)	C.F. (dB/m)	Corrected Reading (dBuV/m)	Limits (dBuV/m)	Margin (dB)	Reading Type (P/Q/A)	Polar (H/V)
80	14.1	+7.71	21.81	40.0	-18.19	P	H
112	14.4	+13.05	27.45	43.5	-16.05	P	H
128	15.4	+13.52	28.92	43.5	-14.58	P	H
167.95	13.8	+12.15	25.95	43.5	-17.55	P	H
240	15.1	+14.47	29.57	46.0	-16.43	P	H
224	9.20	+13.55	22.75	46.0	-23.25	P	H

C.F.(Correction Factor)=Antenna Factor + Cable Loss-Amplifier Gain

Corrected Reading = Metering Reading + C.F. Margin = Corrected Reading - Limits

P= Peak Reading

H= Horizontal Polarization/Antenna

Q= Quasi-peak

V= Vertical Polarization/Antenna

A= Average Reading

Comments: N/A

17. EXTERNAL I/O CABLE CONSTRUCTION DESCRIPTION

CABLE NO:1	
I/O Port: : RF OUTPUT TO ATTENUATOR	Number of I/O ports of this type:1
Number of Conductors: 2	Connector Type: N TYPE
Capture Type: SCREW-IN	Type of Cable used: SHIELDED
Cable Connector Type: METAL	Cable Length:1.5 M
Bundled During Tests: NO	Data Traffic Generated: YES
Remark: N/A	

CABLE NO:2	
I/O Port:: SIGNAL GENERATOR OUT	Number of I/O ports of this type:1
Number of Conductors: 2	Connector Type: N-TYPE
Capture Type: SCREW-IN	Type of Cable used: SHIELDED
Cable Connector Type: METAL	Cable Length:2.5M
Bundled During Tests: NO	Data Traffic Generated: YES
Remark: N/A	

CABLE NO:3	
I/O Port: EUT DC-INPUT	Number of I/O ports of this type:1
Number of Conductors: 8	Connector Type: DC POWER HARNESS
Capture Type: PUSH-IN	Type of Cable used: UN-SHIELDED
Cable Connector Type: PLASTIC	Cable Length: 2.0M
Bundled During Tests: NO	Data Traffic Generated: NO
Remark: N/A	

CABLE NO:4	
I/O Port: RF-IN TO EUT	Number of I/O ports of this type:1
Number of Conductors: 2	Connector Type: N -TYPE
Capture Type: SCREW-IN	Type of Cable used: SHIELDED
Cable Connector Type: METAL	Cable Length:1.5M
Bundled During Tests: NO	Data Traffic Generated: YES
Remark: N/A	

18. CONFIGURATION BLOCK DIAGRAM

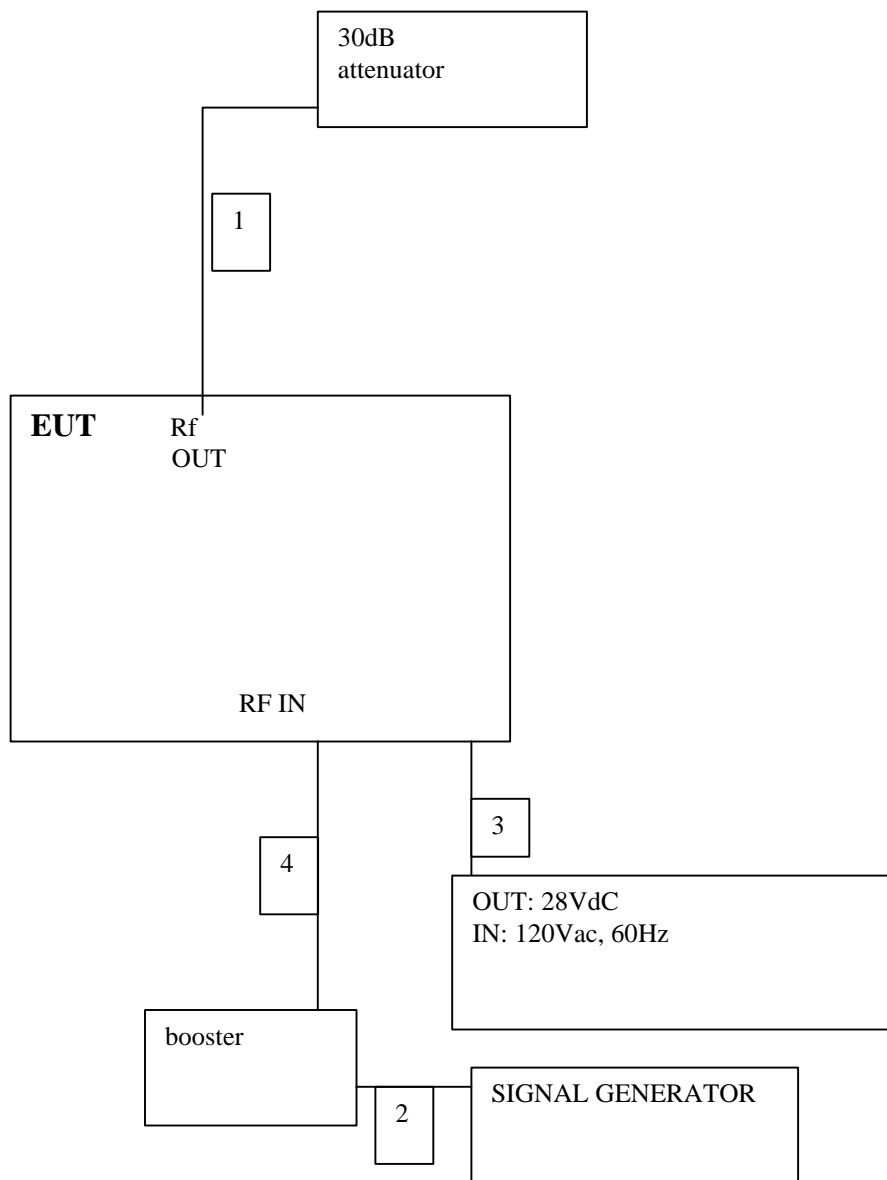

19. FCC PART 2 CERTIFICATION TEST RESULTS:

SECTION 2.1046 RF POWER OUTPUT

Equipment used.

HP Spectrum Analyzer/8566

Narda 30dB Attenuator

HP Directional Coupler/778D

Powerwaves "The Workhorse" low loss cables, 9ft. (loss: 0.85 dB/ft @ 26GHz)

TEST SETUP:

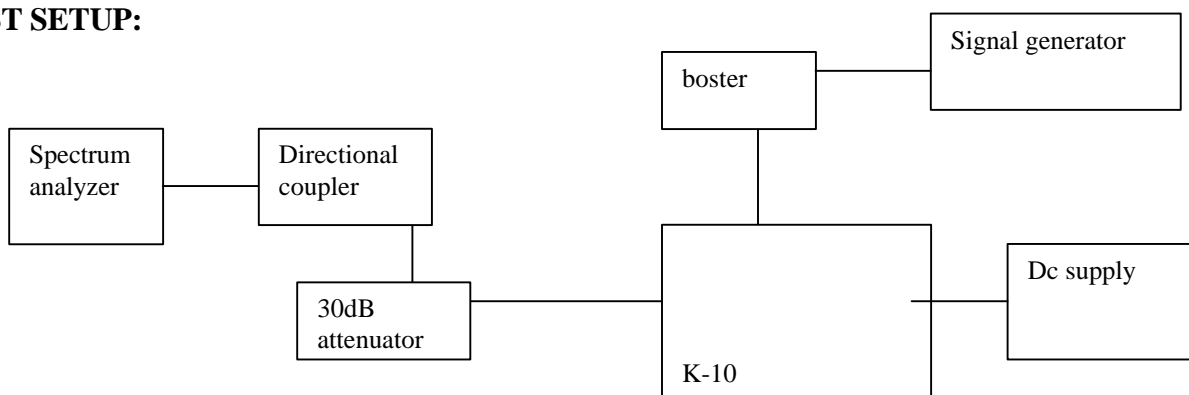

Minimum Requirement:

Section 90.635(b); Technical regulations regarding the use of frequencies in the 851 - 869 MHz bands.

The effective radiated power for base stations shall no be greater than **500Watts**.

Test Result:

Power meter manufactured by Hewlett Packard was used to measure the RF power output.

K-10	
NO. OF AMPLIFIER	MEASURED RF POWER OUTPUT
1	100W

SECTION 2.1047 MODULATION CHARACTERISTICS

Not applicable. EUT is a power amplifier.

SECTION 2.1049 OCCUPIED BANDWIDTH**Equipment used.**

HP Spectrum Analyzer/8566

Narda 30dB Attenuator

HP Directional Coupler/778D

Powerwaves "The Workhorse" low loss cables, 9ft. (loss: 0.85 dB/ft @ 26GHz)

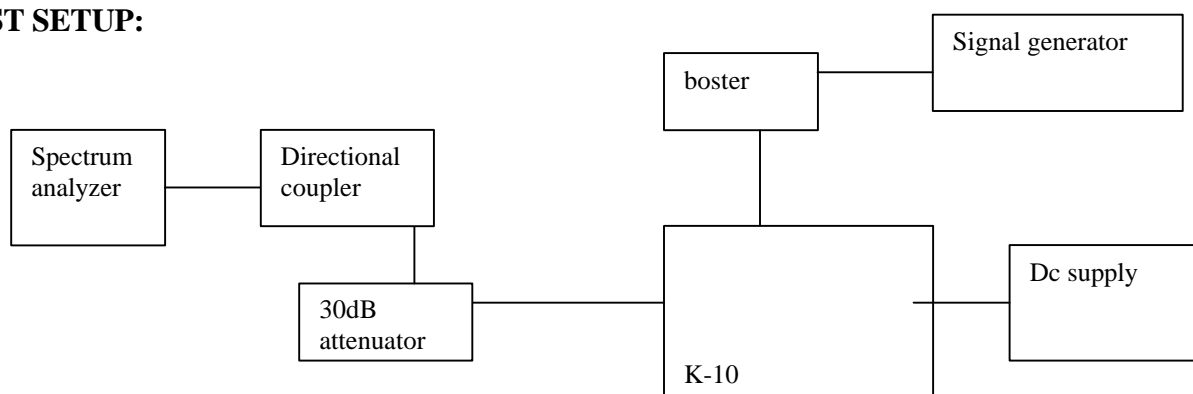
TEST SETUP:**Minimum Requirement:**

Section 2.989 (I); Transmitters designed for other types of modulation –when modulated by an appropriate signal of sufficient amplitude to be representative of the type of service in which used. A description of the input signal should be supplied.

Test Result:

Test results are presented in spectrum analyzer plots. Plots were made for the output of the amplifier and another for the input from signal generator, used to generate **FM** modulation. Table shows order of plots.

<i>K-10</i>	
851MHz(LOW)	
MODULATION TYPE: FM	
	PLOT NUMBER
OUTPUT OF AMPLIFIER	1
IN FROM SIGNAL GENERATOR	2
860MHz(MIDDLE)	
MODULATION TYPE: FM	
	PLOT NUMBER
OUTPUT OF AMPLIFIER	3
IN FROM SIGNAL GENERATOR	4
869MHz(HIGH)	
MODULATION TYPE: FM	
	PLOT NUMBER
OUTPUT OF AMPLIFIER	5
IN FROM SIGNAL GENERATOR	6

SECTION 2.1051 SPURIOUS EMISSION AT ANTENNA TERMINALS**Equipment used.**

HP Spectrum Analyzer/8566

Narda 30dB Attenuator

HP Directional Coupler/778D

Powerwaves "The Workhorse" low loss cables, 9ft. (loss: 0.85 dB/ft @ 26GHz)

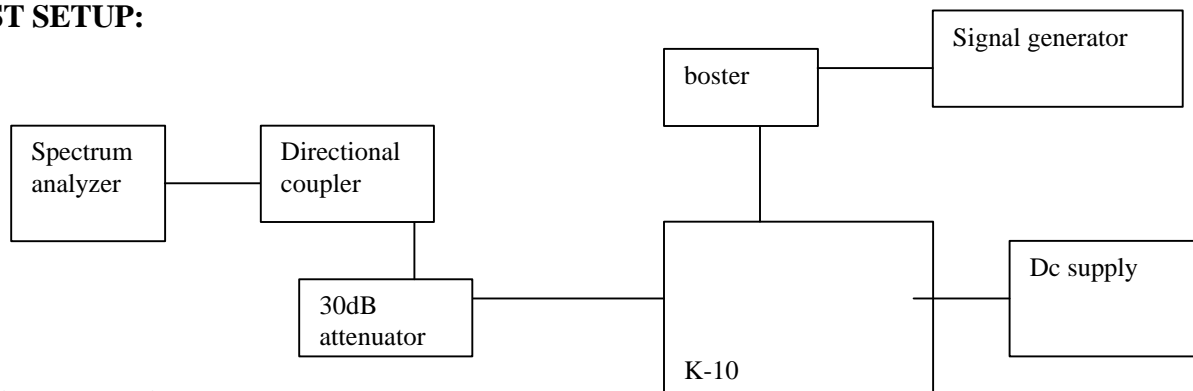
TEST SETUP:**Minimum requirement:**

Technical Limits applied Section 90.210(g); 90.210(h); 90.691 emission mask

The magnitude of each spurious and harmonic emissions that can be detected when the equipment is operated under conditions specified in the instruction manual and/or alignment procedure, shall not be more than $43 + \log(\text{mean output power})$ dBc below the mean power output, which is equivalent to -13 dBm.

Test Procedure:

Spurious emissions tests were performed for Single input signal to amplifier. For all modulations that applies to EUT. Spectrum was scanned from 1 MHz to 10^{TH} of fundamental to search for spurious, harmonics, and intermodulation product emissions.

<i>FREQUENCY 851MHz(Low)</i>	
MODULATION TYPE: FM	
FREQUENCY RANGE	PLOT NUMBER
30 MHz TO 1 GHz	7
1 GHz TO 2 GHz	8
2 GHz TO 8.51 GHz	9
<i>FREQUENCY 860MHz(Middle)</i>	
MODULATION TYPE: FM	
FREQUENCY RANGE	PLOT NUMBER
30 MHz TO 1 GHz	10
1GHz TO 2GHz	11
2 GHz TO 8.60 GHz	12
<i>FREQUENCY 869MHz(High)</i>	
MODULATION TYPE: FM	
FREQUENCY RANGE	PLOT NUMBER
30 MHz TO 1 GHz	13
1 GHz TO 2 GHz	14
2 GHz TO 8.69 GHz	15

SECTION 2.1053 FIELD STRENGTH OF SPURIOUS RADIATION

Emco Horn Antenna/3146

HP Pre-Amp (1 – 26.5 GHz)/8449B

HP Spectrum Analyzer/8593EM

FSY High Pass Filter (1.802GHz)/001

FLEXCO cable/20761; 19ft. coaxial cable (loss: .9dB/ft @ 26GHz)

Test setup

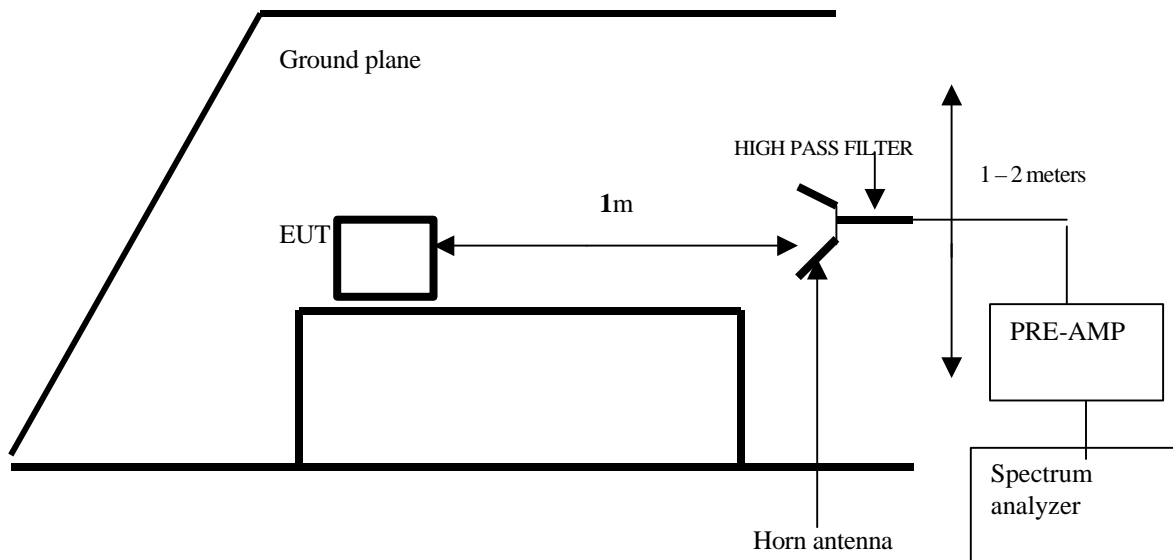

Technical Limits applied Section 90.210(g), 90.210(h), 90.691 emission masks

K-10						
All readings FM Vertical polarized on second Harmonic @ 1800MHz						
$F_o=851\text{MHz}$						
1 Amplifiers 100WATTS Output:						
$(\sqrt{30} * 100) / 3 = 18.3 \text{ V/m} = 145.2\text{dBuV/m}$						
Emission Masks = $43 + 10 \log (100) = 63$						
$145.2 - 63 = 82.2$						
<u>dBuV</u>	<u>AF</u>	<u>CL</u>	<u>AMP</u>	<u>dBuV/m</u>	<u>LIMIT</u>	<u>MARGIN</u>
59.87	26.7	2.1	-35	53.67	82.2	-28.53

$F_o=860\text{MHz}$

1 Amplifiers 100WATTS Output:

$$(\sqrt{30} * 100) / 3 = 18.3 \text{ V/m} = 145.2\text{dBuV/m}$$

$$\text{Emission Masks} = 43 + 10 \log (100) = 63$$

$$145.2 - 63 = 82.2$$

<u>dBuV</u>	<u>AF</u>	<u>CL</u>	<u>AMP</u>	<u>dBuV/m</u>	<u>LIMIT</u>	<u>MARGIN</u>
64.20	26.7	2.1	-35	58	82.2	-24.2

$F_o=869\text{MHz}$

1 Amplifiers 100WATTS Output:

$$(\sqrt{30} * 100) / 3 = 18.3 \text{ V/m} = 145.2\text{dBuV/m}$$

$$\text{Emission Masks} = 43 + 10 \log (100) = 63$$

$$145.2 - 63 = 82.2$$

<u>dBuV</u>	<u>AF</u>	<u>CL</u>	<u>AMP</u>	<u>dBuV/m</u>	<u>LIMIT</u>	<u>MARGIN</u>
68.3	26.7	2.1	-35	62.1	82.2	-20.1

b) Radiated emissions data of harmonics at 1 meter from second to 10fo

Sheet1

8/7/98
 Juan Martinez
 Site A (1 meter)

8/7/98
 Juan Martinez
 Site A (1 meter)

Powerwave Technologies
 K-10 CONTINUOUS DUTY POWER AMPLIFIER

F (MHz)	READING (dBuV)	AF (dB)	CL (dB)	Amp (dB)	DIST (dB)	DUTY (dB)	Other (dB)	Total (dBuV/m)	Limit (dBuV/m)	Margin (dB)
851(Low)										
1701	60.3	26	1.96	0	-10.5	0	0	77.76	82	-4.24
2552	76.3	29.2	3.3	-35	-10.5	0	1	64.3	82	-17.7
3403	55.1	33.1	4.13	-35	-10.5	0	1	47.83	82	-34.17
4254	77.4	32.3	4.62	-35	-10.5	0	1	69.82	82	-12.18
5105	49.8	34.3	4.95	-35	-10.5	0	1	44.55	82	-37.45
5957	49.1	35.3	5.28	-35	-10.5	0	1	45.18	82	-36.82
6807	40.7	36	6.3	-35	-10.5	0	1	38.5	82	-43.5
7858	39.6	36.9	7.2	-35	-10.5	0	1	39.2	82	-42.8
8510	45.9	37.7	7.56	-35	-10.5	0	1	46.66	82	-35.34
860(MIDDLE)										
1720	61.2	26	1.96	0	-10.5	0	0	78.66	82	-3.34
2579	68.5	29.2	3.3	-35	-10.5	0	1	56.5	82	-25.5
3439	55.1	33.1	4.13	-35	-10.5	0	1	47.83	82	-34.17
4299	77.4	32.3	4.62	-35	-10.5	0	1	69.82	82	-12.18
5159	49.8	34.3	4.95	-35	-10.5	0	1	44.55	82	-37.45
6020	49.1	35.3	5.28	-35	-10.5	0	1	45.18	82	-36.82
6880	40.7	36	6.3	-35	-10.5	0	1	38.5	82	-43.5
7740	39.6	36.9	7.2	-35	-10.5	0	1	39.2	82	-42.8
8600	45.6	37.7	7.56	-35	-10.5	0	1	46.36	82	-35.64
869(HIGH)										
1737	62.5	26	1.96	0	-10.5	0	0	79.96	82	-2.04
2606	70.4	29.2	3.3	-35	-10.5	0	1	58.4	82	-23.6
3475	68.2	33.1	4.13	-35	-10.5	0	1	60.93	82	-21.07

Page 1

Sheet1

4344	75.2	32.3	4.62	-35	-10.5	1	67.62	82	-14.38
5213	51.3	34.3	4.95	-35	-10.5	1	46.05	82	-35.95
6083	44.3	35.3	5.28	-35	-10.5	1	40.38	82	-41.62
6951	41.3	36	6.3	-35	-10.5	1	39.1	82	-42.9
7821	40.8	36.9	7.2	-35	-10.5	1	40.4	82	-41.6
8690	44.2	37.7	7.56	-35	-10.5	1	44.96	82	-37.04

ANALYZER BANDWIDTH SETTINGS

Res Bw: 1MHz
 Video Bw: 1MHz

Peak(P):

DIST: Correction to extrapolate reading to 3m specification distance

3ft measurement distance: -10.5 dB

OTHER: High pass filter insertion loss (1.802GHz)

AF: Antenna Factor

AMP: Pre-amp gain

DUTY: Duty Cycle correction factor

CL: CABLE LOSS

SECTION 2.1055 FREQUENCT STABILITY

Not Applicable. Device is a power amplifier.