

# Microwave Data Systems Inc. TRM 450 OEM Series



## 410–470 MHz Data Transceivers

MDS 05-4121A01, Rev. A  
DECEMBER 2003

industrial/wireless/performance







---

# TABLE OF CONTENTS

---

<b>1.0 INTRODUCTION</b> .....	<b>7</b>
1.1 Modem Speed versus Channel Bandwidth .....	8
1.2 Frequency Coverage .....	8
1.3 Radio Operating Modes .....	8
Single Frequency (Simplex) Operation .....	8
Switched-Carrier Operation (Half-Duplex) .....	9
1.4 Applications .....	9
Point-to-Multipoint, Multiple Address Systems (MAS) .....	9
Point-to-Point System .....	10
1.5 Model Number Codes .....	11
<b>2.0 INSTALLATION DESIGN</b> .....	<b>12</b>
2.1 Mounting the Transceiver .....	13
2.2 Interface Requirements .....	13
2.3 Antennas and Feedlines .....	14
Antennas .....	14
Feedlines .....	15
2.4 Primary Power (3.3 Vdc) .....	15
DC Supply Connection .....	15
Shutdown Mode (Energy Conservation).....	16
2.5 Data Interface Connections .....	16
<b>3.0 TRANSCEIVER CONFIGURATION AND DIAGNOSTIC COMMANDS</b> .....	<b>19</b>
3.1 Error Messages .....	21
3.2 Initial Installation—Radio and Data Configuration .....	21
<b>4.0 TROUBLESHOOTING</b> .....	<b>23</b>
<b>5.0 TECHNICAL REFERENCE</b> .....	<b>24</b>
5.1 TRM 450 Transceiver Specifications .....	24
5.2 Test and Evaluation Assembly .....	25
5.3 Vendors for Connectors .....	28
5.4 dBm-Watts-Volts Conversion Chart .....	30
<b>6.0 GLOSSARY OF TERMS</b> .....	<b>31</b>



## Copyright Notice

This Installation and Operation Guide and all software described herein are protected by **copyright: 2003 Microwave Data Systems Inc.** All rights reserved.

Microwave Data Systems Inc. reserves its right to correct any errors and omissions in this publication.

## Antenna Installation Warning

1. All antenna installation and servicing is to be performed by **qualified technical personnel** only. When servicing the antenna, or working at distances closer than those listed below, *ensure the transmitter has been disabled.*
2. Typically, the antenna connected to the transmitter is a directional (high gain) antenna, fixed-mounted on the side or top of a building, or on a tower. Depending upon the application and the gain of the antenna, the total composite power could exceed 90 watts ERP. The antenna location should be such that only qualified technical personnel can access it, and that under normal operating conditions no other person can touch the antenna or approach within **2.3 meters** of the antenna.

### RF Exposure



Separation distances required for FCC RF Exposure compliance

**Antenna Gain versus Recommended Safety Distance (TRM 450 Series)**

	Antenna Gain (TRM 450 Series)		
	0-5 dBi	5-10 dBi	10-16.5 dBi
<b>Minimum RF Safety Distance</b>	0.6 meter	1.06 meters	2.3 meters

## ISO 9001 Registration

Microwave Data Systems adheres to this internationally accepted quality system standard.

## MDS Quality Policy Statement

We, the employees of Microwave Data Systems Inc., are committed to understanding and exceeding our customer's needs and expectations.

- We appreciate our customer's patronage. They are our business.
- We promise to serve them and anticipate their needs.
- We are committed to providing solutions that are cost effective, innovative and reliable, with consistently high levels of quality.
- We are committed to the continuous improvement of all of our systems and processes, to improve product quality and increase customer satisfaction.



## ESD Notice

To prevent malfunction or damage to this product, which may be caused by Electrostatic Discharge (ESD), the radio should be properly grounded at the time of installation. In addition, the installer or maintainer should follow proper ESD precautions, such as touching a bare metal object to dissipate body charge, prior to touching components or connecting/disconnecting cables.

## Manual Revision and Accuracy

While every reasonable effort has been made to ensure the accuracy of this manual, product improvements may result in minor differences between the manual and the product shipped to you. If you have additional questions or need an exact specification for a product, please contact our Customer Service Team using the information at the back of this guide. In addition, manual updates can often be found on the MDS Web site at [www.microwavedata.com](http://www.microwavedata.com).

## FCC Part 15 Notice

This equipment has been tested and found to comply with the limits for a Class B digital device, pursuant to Part 15 of the FCC Rules. These limits are designed to provide reasonable protection against harmful interference in a residential installation. This equipment generates, uses, and can radiate radio frequency energy and, if not installed and used in accordance with the instructions, may cause harmful interference to radio communications. However, there is no guarantee that interference will not occur in a particular installation. If this equipment does cause harmful interference to radio or television reception, which can be determined by turning the equipment off and on, the user is encouraged to try and correct the interference by one or more of the following measures:

- Reorient or locate the receiving antenna.
- Increase the separation between the equipment and receiver.
- Connect the equipment into an outlet on a circuit different from that to which the receiver is connected.
- Consult the dealer or an experienced radio/TV technician for help.

This Class B digital apparatus complies with Canadian ICES-003. Cet appareil numérique de la classe B est conforme à la norme NMB-003 du Canada.

Operation is subject to the following two conditions: (1) this device may not cause interference, and (2) this device must accept any interference, including interference that may cause undesired operation of the device.

Changes or modifications not expressly approved by the party responsible for compliance could void the user's authority to operate the equipment.



## 1.0 INTRODUCTION

This guide presents installation and operating instructions for the TRM 450 digital radio transceiver. The radio is a compact, modular board well suited to user-designed customer integration with remote terminal units (RTUs), programmable logic controllers (PLCs), automatic banking machines, or similar equipment.

The transceiver (Figure 1) is a data telemetry radio designed to operate in a point-to-multipoint environment, such as electric utility Supervisory Control and Data Acquisition (SCADA) and distribution automation, gas field automation, water and wastewater SCADA, and on-line transaction processing applications. The radio employs microprocessor control to provide highly reliable communications, even under adverse conditions.

TRM 450 radios use Gaussian-mean shift keying (GMSK) modulation.



Figure 1. TRM 450 Data Transceiver

## 1.1 Modem Speed versus Channel Bandwidth

The TRM 450 can be configured by the user to one-of-six arrangements dependent on the permissible values of over-the-air data baud rate (**BAUD**), Gaussian filtering (**BT**), and channel bandwidth (**BW**). The valid configurations are:

**Table 1. Permissible Data Configurations**

Baud (bps)	Receive Bandwidth (BW)	BT
19200	25.0 kHz	.3
16000	25.0 kHz	.3
9600	25.0kHz	.5
9600	12.5 kHz	.3
8000	25 kHz	.5
8000	12.5 kHz	.3
4800	25.0 kHz	.5
4800	12.5 kHz	.5

The current configuration will be displayed by the **MODEM** command. These parameters are independent of any other user-controllable operating parameter.

## 1.2 Frequency Coverage

The TRM 450 series radios are available for operation in one of three the frequency subbands between 410–470 MHz. The subbands are: 410–430 MHz, 430–450 MHz and 450–470 MHz. Any combination of transmitter and receiver operating frequencies can be programmed within the subband of the TRM 450, including a simplex (TX = RX) pair.

---

**NOTE:** Each of the three radio frequency ranges (subband) are factory set and cannot be changed by the user.

---

## 1.3 Radio Operating Modes

### Single Frequency (Simplex) Operation

Single frequency operation (also known as simplex) is a special case of switched carrier operation. Single frequency operation is *automatically* selected whenever the transmit and receive frequencies are set to the same value.





## Switched-Carrier Operation (Half-Duplex)

Switched-carrier operation is a half-duplex mode where the master station transmitter is keyed to send data and unkeyed to receive. MDS' TRM 450 radios operate in switched-carrier mode and are keyed when data is present.

---

**NOTE:** TRM 450 radios do not support full-duplex operation (i.e., transmitting and receiving at the same time). For information on other MDS products that provide this capability, contact your sales representative.

---

## 1.4 Applications

### Point-to-Multipoint, Multiple Address Systems (MAS)

Point-to-multipoint (MAS) is the most common application of the transceiver. It consists of a central master station and several associated remote units as shown in [Figure 2](#). An MAS network provides communications between a central host computer and remote terminal units (RTUs) or other data collection devices. The operation of the radio system is “transparent” to the computer equipment. That is, the radio system transports the data in its original form, making no changes to the data format.

Often, the radio system is used to replace a network of remote monitors currently linked to a central location by leased telephone lines. At the central office of such a system, there is usually a large mainframe computer and some means of switching between individual lines coming from each remote monitor. In this type of system, there is a modulator/demodulator (modem) at the main computer and at each remote site, usually built into the remote monitor itself. Since the cost of leasing a dedicated-pair telephone line is quite high, radio is frequently used as an alternative communication medium.

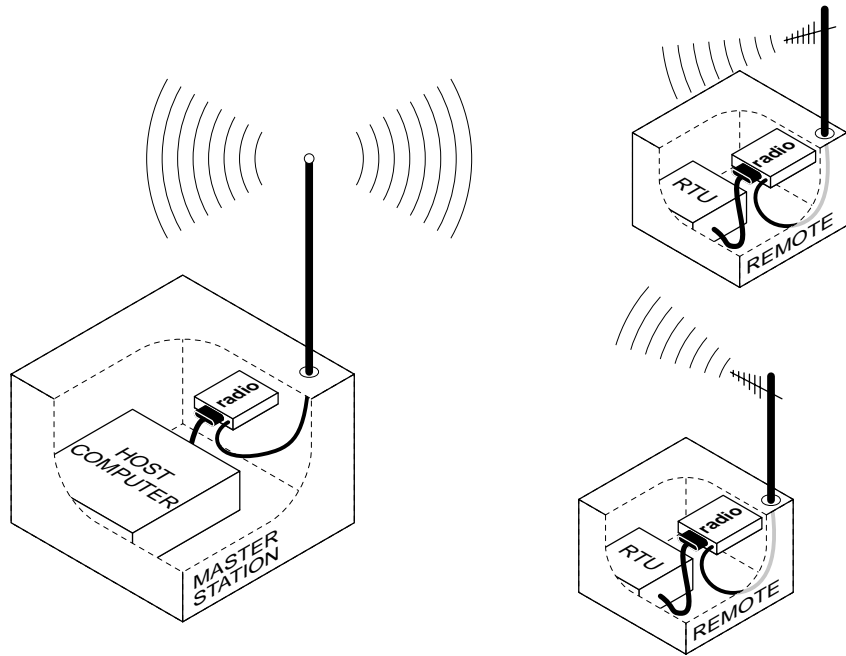

**Figure 2. MAS Point-to-Multipoint Network**  
*(Two remote stations shown—four or more are typically used)*

**Point-to-Point System**

Where permitted, the transceiver may also be used in a point-to-point arrangement. A point-to-point system consists of just two radios—one serving as a master and the other as a remote—as shown in Figure 3. It provides a simplex or half-duplex communications link for the transfer of data between two locations.

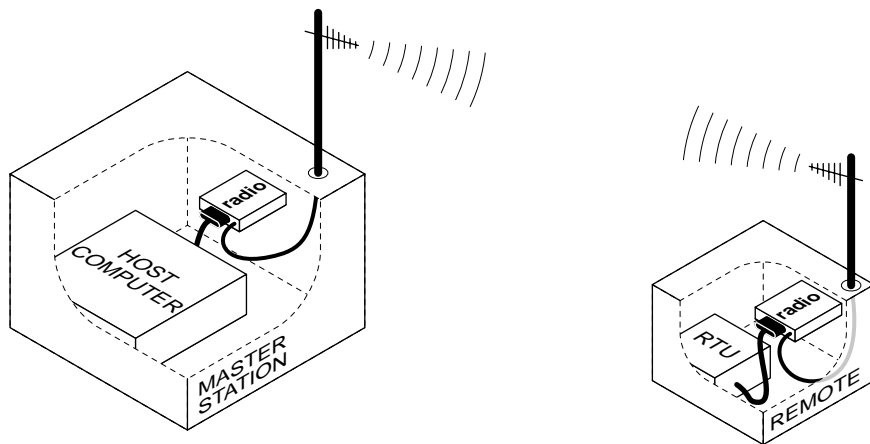

**Figure 3. Typical Point-to-Point Link**



## 1.5 Model Number Codes

The radio model number is printed on the PC board or on the radio enclosure, and provides key information about how the radio was configured when it was shipped from the factory. See Figure 4 for an explanation of the model number characters.

**Figure 4. TRM 450 Model Number Codes**  
*(As found on the serial number and identification label)*

**THIS INFORMATION IS  
 SUBJECT TO  
 CHANGE.**

**DO NOT USE FOR  
 PRODUCT ORDERING.**

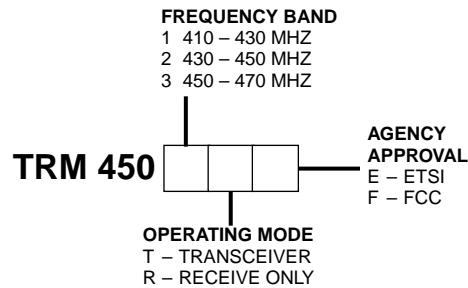

## 2.0 INSTALLATION DESIGN

The TRM 450 is designed to be part of a larger electronic device or system. It must be provided with adequate and stable primary power, a complementary data interface and RF antenna system connections. An appropriate antenna is the only external device that is needed.

Connections to the TRM 450 are through two connections: data and power through an AVX Series 5046 fine-pitch (DATA INTERFACE) connector and RF signalling through PCB pads to a SMT PCB-to-PCB pressure-contact coaxial connector. These connections require a stable support for the TRM 450 module with positive pressure by the RF connector on the RF I/O pads (J300/301). Figure 5 shows the external connections for the transceiver.

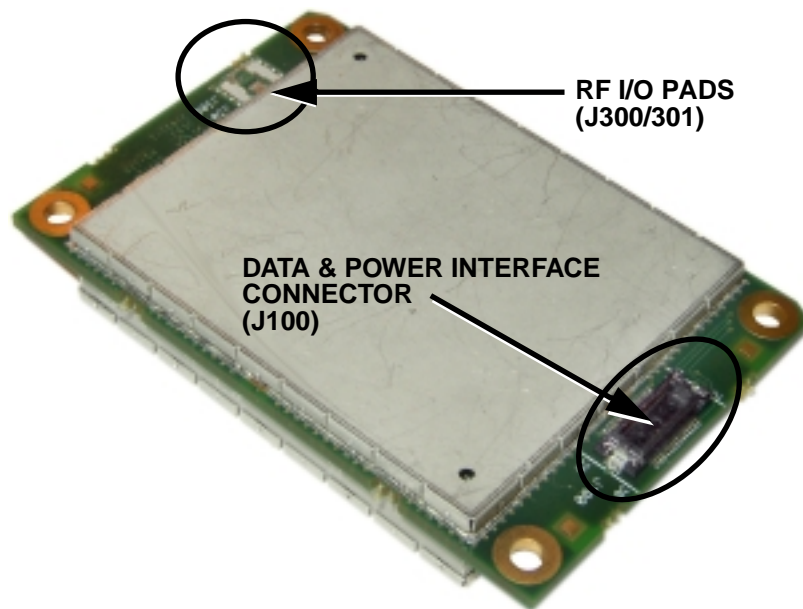

**Figure 5. External Connections to the Transceiver Board**  
(Bottom View of PCB)

The TRM 450 has all of its electronic circuitry enclosed in RF shields to minimize interaction with nearby electronic products. The transceiver module is compliant with FCC Part 90 and Part 15 in the 410–470 MHz band. The transmitter can be set to produce 2 Watts of RF output. Careful selection and/or design of the radio transmission line is important to minimizing RFI to nearby electronic devices.

This unit must be provided with a good antenna system optimal communication range and reliability. A secondary benefit is an opportunity to run the system at the lowest possible power level, a lower primary power consumption, and reduced chances of interference.

The data interface will support a variety of system designs. Use only the required pins for the application. Refer to the complete list of pin functions in Table 4 on Page 17.

## 2.1 Mounting the Transceiver

Figure 6 shows the mounting dimensions of the transceiver PC board. The board should be secured to the mounting surface using the holes provided at each corner of the assembly. (Fasteners are not supplied.)

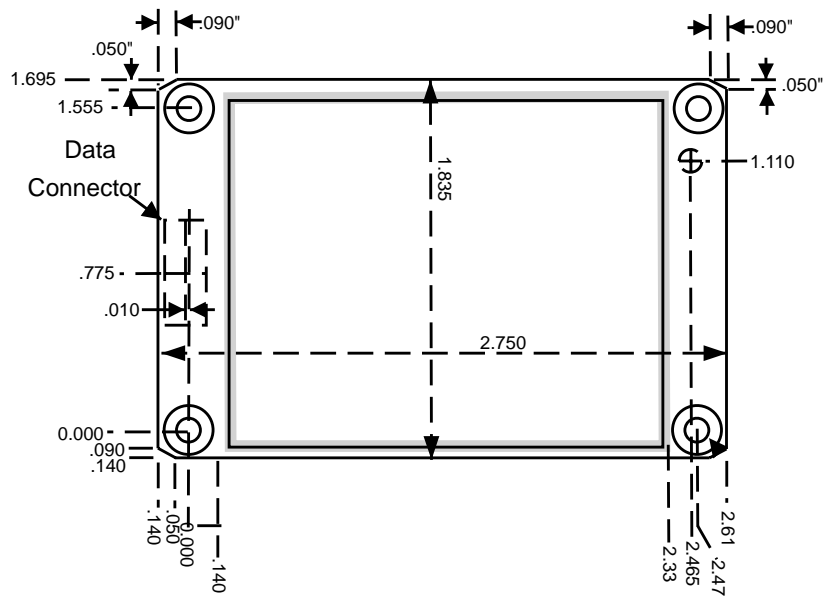

Figure 6. Transceiver Mounting Dimensions

## 2.2 Interface Requirements

It is highly beneficial to provide for electronic access to the TRM 450 module after it is installed in your product or system. This allows for module configuration and control, frequency changes when needed, antenna system optimization, and diagnostic activities.

In addition, it would be beneficial to provide field service personnel a technique for directly monitoring the test and diagnostic indicators produced by the unit to indicate the incoming radio signal strength (RSSI), and the radio synthesizer's unfiltered out-of-lock indicator.



Table 2 summarizes minimal recommended access requirements for field setup and servicing of the TRM 450 radio transceiver. Other interface signal functions may be of use to field service personnel or as part of a diagnostic design for the whole user-defined package.

**Table 2. Configuration and Evaluation Signals**

Function	Data Interface Pin	Signal Type)	Description
Enable Configuration	11	Low = Enabled	Enables terminal interaction with module. Disables payload throughput.
Received (RF) Signal Strength Signal Indicator—RSSI	12	Analog 0–3 Vdc	Aid to aiming antenna system and determining presence of radio signals
Synthesizer Lock	2	H = Locked L = Out-of-Lock	Unprocessed indicator of state of transceiver's frequency synthesizer. Signal may contain inconsequential transients

### 2.3 Antennas and Feedlines

#### Antennas

The transceiver can be used with a number of antennas. The exact style depends on the physical size and layout of the radio system. Suitable antennas are available from several manufacturers, including MDS.

At master stations, omni-directional antennas (Figure 7) are typically used to provide equal coverage to all remote sites in the network.

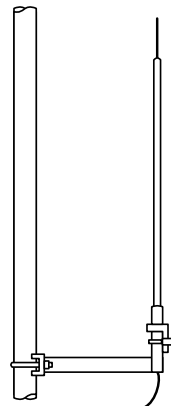

**Figure 7. Typical Omni-directional Antenna for Master Stations (Shown mounted to mast)**



At remote sites, a directional Yagi (Figure 8) or corner reflector antenna is generally recommended to minimize interference to and from other users.

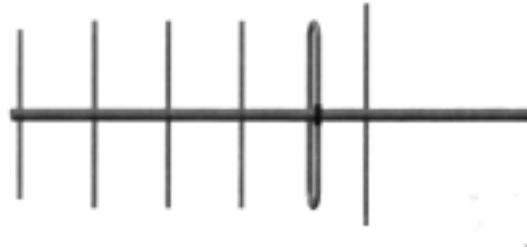

**Figure 8. Typical Yagi Antenna for Remote Sites**

### Feedlines

The selection of antenna feedline is very important. Poor quality cables should be avoided as they result in power losses that may reduce the range and reliability of the radio system.

Table 3 shows the losses that occur when using various lengths and types of cable at 400 MHz. Regardless of the type of cable used, it should be kept as short as possible to minimize signal loss.

**Table 3. Length vs. Loss in Coaxial Cables at 400 MHz**

Cable Type	10 Feet (3.05 Meters)	50 Feet (15.24 Meters)	100 Feet (30.48 Meters)	500 Feet (152.4 Meters)
RG-8A/U	0.51dB	2.53 dB	5.07 dB	25.35 dB
1/2 inch HELIAX	0.12 dB	0.76 dB	1.51 dB	7.55 dB
7/8 inch HELIAX	0.08 dB	0.42 dB	0.83 dB	4.15 dB
1-1/4 inch HELIAX	0.06 dB	0.31 dB	0.62 dB	3.10 dB
1-5/8 inch HELIAX	0.05 dB	0.26 dB	0.52 dB	2.60 dB

## 2.4 Primary Power (3.3 Vdc)

### DC Supply Connection

The transceiver can be operated from any well-filtered 3.3 Vdc power source through the DATA INTERFACE connector. The power supply must be capable of providing at least 1.5 Amperes and provide current limiting even if you intend to operate the radio at low power (0.5 Watts).



NOTE: The radio is designed for use in *negative* ground systems only. There is no fuse or reverse polarity protection provided on the TRM 450 PCB assembly.



The positive (+) DC power must be provided through pins 23, 24, 25, 26, 27, and 28. The data signal and DC power current return (–) should be connected to pins 1, 7, 9, 19, 20, 21, 22, and 30. (See Figure 5 on Page 12 for details.)

### Shutdown Mode (Energy Conservation)

In some installations, such as at solar-powered sites, it may be necessary to keep the transceiver’s power consumption to an absolute minimum. This can be accomplished by configuring the data device (RTU, PLC, etc.) to ground the DATA INTERFACE connector Pin 29 to power-down the radio until communication to other devices is needed. All radio and microprocessor activity is disabled when the radio is in the shutdown mode. When the ground is removed from Pin 29, the radio is ready to operate within 75 milliseconds.

## 2.5 Data Interface Connections

The transceiver’s DATA INTERFACE connector is configured as a DCE (modem) and supports over-the-air asynchronous data rates up to 19200 bps. (4800, 8000, 9600, 16000, and 19200 bps) The DATA INTERFACE is normally connected to a device/circuit with a TTL interface. Refer to Figure 9 and Table 4 for a detailed description of each pin on the DATA INTERFACE connector.



Some pins on the DATA INTERFACE connector are used for factory testing. Use *only* the required pins for the application. Damage may result if improper connections are made.



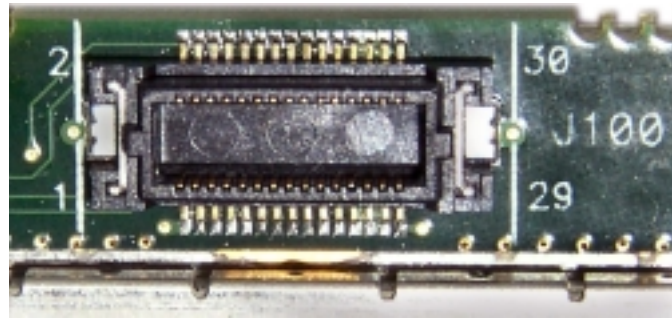

**Figure 9. Data Interface Connector**  
(As viewed from above)

**Table 4. DATA INTERFACE Connector Pinouts**

Pin Number	Input/ Output	Pin Description
1	IN/OUT	<b>Ground</b>
2	OUT	<b>RF synthesizer lock detect signal</b> <ul style="list-style-type: none"> <li>• High = locked (Radio ready for service)</li> <li>• Low = Out-of-lock (Radio disabled)</li> <li>• Raw / “unfiltered”</li> </ul>
3	IN	<b>TX Data—Transmit Data</b> (payload) in normal operation
4	OUT	<b>CD—Carrier Detect</b> <ul style="list-style-type: none"> <li>• Low whenever RSSI exceeds the programmed CDR threshold.</li> <li>• Detects RF activity on the radio channel regardless of the signals modulation type or data protocol.</li> </ul>
5	IN/OUT	<b>Ground</b> (Power and signal)
6	OUT	<b>RX Clock—Always applicable when receiving</b> <ul style="list-style-type: none"> <li>• Goes from low to high at the center of each RX Data bit (receive mode)</li> <li>• Provided when transmitting if “<b>CLK RX</b>” is programmed</li> <li>• Goes from low to high to request each new TXD bit</li> <li>• Continuously high when transceiver is in Configuration Mode (J100, Pin 11 = Low)</li> </ul>
7	IN/OUT	<b>Ground</b> (Power and signal)
8	OUT	<b>TX Clock—Transmit Data Clock</b> <ul style="list-style-type: none"> <li>• Only applicable when “<b>CLK TX</b>” is programmed and TX ON is asserted</li> <li>• Clock goes from low to high to request each new TXD bit</li> <li>• Continuously high when in Configuration Mode (J100, Pin 11 = Low), or when “<b>CLK RX</b>” is selected</li> </ul>
9	IN/OUT	<b>Ground</b> (Power and signal)

**Table 4. DATA INTERFACE Connector Pinouts (Continued)**

Pin Number	Input/Output	Pin Description
10		Do not connect—Reserved for factory use only.
11	IN	<b>CONFIG—Configure Radio</b> <ul style="list-style-type: none"> <li>• High puts radio in normal payload mode to receive or transmit data at the programmed rate</li> <li>• Low puts radio in setup mode to communicate with the processor at 38.4 kbps asynchronously</li> </ul>
12	OUT	<b>RSSI—Receive Signal Strength Indicator</b> <ul style="list-style-type: none"> <li>• Analog voltage between 0 and 3 Vdc proportional to signal strength on the channel</li> </ul>
13	IN	<b>TX ON—Request to key radio transmitter</b> <ul style="list-style-type: none"> <li>• High puts radio in transmit mode</li> <li>• Low puts radio in receive mode</li> </ul>
14	OUT	<b>RX Data—Receive Data</b> <ul style="list-style-type: none"> <li>• Receive data (off-the-air) in normal operation</li> <li>• Control data from the processor in setup mode</li> </ul>
15	OUT	<b>RX Audio—Filtered receive audio</b> <ul style="list-style-type: none"> <li>• For test purposes only</li> </ul>
16		Do not connect—Reserved for factory use only.
17		Not used – Do not connect
18		<b>Vcc</b> —Regulated +3.3 Vdc power for the transceiver
19	IN/OUT	<b>Ground</b> (Power and signal)
20	IN/OUT	<b>Ground</b> (Power and signal)
21	IN/OUT	<b>Ground</b> (Power and signal)
22	IN/OUT	<b>Ground</b> (Power and signal)
23	IN	<b>Vcc</b> —Regulated +3.3 Vdc power for the transceiver
24	IN	<b>Vcc</b> —Regulated +3.3 Vdc power for the transceiver
25	IN	<b>Vcc</b> —Regulated +3.3 Vdc power for the transceiver
26	IN	<b>Vcc</b> —Regulated +3.3 Vdc power for the transceiver
27	IN	<b>Vcc</b> —Regulated +3.3 Vdc power for the transceiver
28	IN	<b>Vcc</b> —Regulated +3.3 Vdc power for the transceiver
29	IN	<b>Shutdown Mode</b> <ul style="list-style-type: none"> <li>• Low puts radio in low-power shutdown</li> <li>• High or open allows normal operation</li> </ul>
30	IN/OUT	<b>Ground</b> (Power and signal)



### 3.0 TRANSCEIVER CONFIGURATION AND DIAGNOSTIC COMMANDS

The transceiver’s configuration and diagnostics are performed through the radio’s DATA INTERFACE connector through a “dumb” data terminal interface—either a personal computer or dedicated terminal. An EIA/RS-232 to TTL converter circuit may be required depending on your installation design. Configuration and diagnostic activities may be performed with the TRM 450 removed from the user equipment or as an installed module in your design.

If you choose to setup the TRM 450 before its final installation, you may find using MDS’ TRM 450 Test and Evaluation Assembly a convenient tool. (See *Test and Evaluation Assembly* on Page 25 for more detail.)

Table 5 lists each command entry and a brief description of its purpose. Programmable information is shown in brackets [ ] following the command name.

To enter a command, type the command, followed by an **ENTER** keystroke. For programming commands, the command is followed by **SPACE** and the appropriate information or values, then **ENTER**.

**Table 5. Command Summary**

Command	Function
MODEM	<p><b>MODEM—Data Configuration</b></p> <p>Response indicates:</p> <p>Payload data rate (<b>BAUD</b>)                      + Gaussian Bandwidth x Data Rate (<b>BT</b>)                      + Channel Spacing (<b>BW</b>)</p> <p>For example: <b>9.6Kbps BT=.5 25KHz.</b></p> <p>NOTE: Provides only an informational display. The command cannot be used to configure the radio.</p>
TX [xxx.xxxxx]	<p><b>Transmit RF Channel Frequency</b></p> <ul style="list-style-type: none"> <li>• The frequency must be within the operating range for the unit.</li> <li>• Up to 5 digits can be entered after the decimal point. Trailing zeros are not required.</li> <li>• Frequencies can be in either 5 or 6.25 kHz increments.</li> </ul>
BAUD [xxxxx]	<p><b>“Over-the-Air” Modem Speed</b></p> <ul style="list-style-type: none"> <li>• Options: 4800, 8000, 9600, 16000 and 19200</li> <li>• For synchronous payload data through the DATA INTERFACE port (J100)</li> </ul> <p>NOTES:</p> <ul style="list-style-type: none"> <li>• Must complement BT and BW values. (See Table 1 on Page 8.)</li> <li>• Data rate for serial data (RXD/TXD) diagnostic/command interface is always 38400</li> </ul>

**Table 5. Command Summary (Continued)**

Command	Function
BT [.x]	<p><b>Relative TX Bandwidth</b></p> <ul style="list-style-type: none"> <li>Valid options are .3 and .5</li> <li>Leading zero (Ø) not permitted</li> </ul> <p>NOTE: Must complement BAUD and BW values. (See Table 1 on Page 8.)</p>
BW [xx.x]	<p><b>Channel Bandwidth</b></p> <ul style="list-style-type: none"> <li>Options: 25 and 12.5 kHz</li> </ul> <p>NOTE: Must complement BT and BW values. (See Table 1 on Page 8.)</p>
CLK [xx]	<p><b>Clock Output Pin</b></p> <p>Selects which serial clock line to use for transmit operation.</p> <ul style="list-style-type: none"> <li>Options: TX and RX</li> <li>TX = Pin 8/TXC</li> <li>RX = Pin 6/RXC</li> </ul>
CDR [-xxx]	<p><b>Receiver Carrier Detect Threshold</b></p> <ul style="list-style-type: none"> <li>Inhibits the receiver from processing an incoming signal unless it is above the setting's level.</li> <li>Range: -50 to -120</li> </ul> <p>NOTE: A setting of -120 removes any limitation on signal detection.</p>
CDT [-xxx]	<p><b>Transmit Carrier Detect Threshold</b></p> <p>Inhibits the transmitter from operating in the presence of a strong on-channel signal until the signal level is below the setting level.</p> <ul style="list-style-type: none"> <li>Range: -50 to -120</li> </ul> <p>NOTES:</p> <ul style="list-style-type: none"> <li>-50 will effectively allow transmissions anytime</li> <li>-120 will effectively prohibit transmissions.</li> <li>Minus sign (-) required for data entry</li> </ul>
PWR [x]	<p><b>RF Power Output Level</b></p> <p>Options:</p> <p>H = High Power (2 Watts) L = Low Power (0.5 Watts)</p>
SCRAM [xxx]	<p><b>Data Scrambler/Descrambler ON/OFF</b></p> <p>Options: ON or OFF</p>
SREV [xxx]	<p><b>Software Revision of installed firmware</b></p>
SER	<p><b>Serial Number of the radio</b></p>
RSSI	<p><b>Received Signal Strength Indicator</b></p> <ul style="list-style-type: none"> <li>Displays the current received RF signal level</li> <li>One measurement per request by command</li> <li>Reading is accurate to within 3 dB from -100 dBm to -60 dBm</li> </ul> <p>NOTE: A continuous RSSI signal available during receive state on the DATA INTERFACE connector (J100-Pin12).</p>



**Table 5. Command Summary (Continued)**

Command	Function
OWN [xxx]	<p><b>Owner’s Message</b></p> <p>Displays an optional owner message</p> <ul style="list-style-type: none"> <li>• Enter <b>OWN</b> to display current entry.</li> <li>• Enter <b>OWN</b> followed by up to 30 characters to program.</li> </ul>
KEY	<p><b>Transmitter Carrier Key</b></p> <ul style="list-style-type: none"> <li>• Test command for technicians to key the radio with a unmodulated carrier.</li> <li>• Use DKEY command to cease transmission</li> </ul> <p>NOTES:</p> <ul style="list-style-type: none"> <li>• Use only for test purposes.</li> <li>• No time-out timer on this function.</li> </ul>
DKEY	<p><b>Unkey Transmitter Test Carrier</b></p>

### 3.1 Error Messages

Listed below are some possible error messages that may be encountered when using the terminal interface:

**UNKNOWN COMMAND**—The command was not recognized. Refer to the command description for command usage information.

**INCORRECT ENTRY**—The command format or its associated values were not valid. Refer to the command description for command usage information.

**COMMAND FAILED**—The command was unable to successfully complete. This may indicate an internal software problem.

**NOT PROGRAMMED**—Software was unable to program the internal radio memory or the requested item was not programmed. This is a serious internal radio error. Contact MDS for assistance.

**TEXT TOO LONG**—Response to **OWN** command when too many characters have been entered. Refer to the command description for command usage information.

**NOT AVAILABLE**—The entered command or parameter was valid, but it referred to a currently unavailable choice. Refer to the command description for command usage information.

### 3.2 Initial Installation—Radio and Data

## Configuration

Below are the basic steps for setting up of the transceiver once it is installed in the user's product. In many cases, these steps alone are sufficient to complete the installation. This procedure assumes the TRM 450 has been installed in your system/product and suitable connections have been provided for a terminal interface and antenna.

3. Install the antenna and antenna feedline for the station. Preset directional antennas in the desired direction of transmission and reception.
4. Connect a terminal (computer with emulations software) to the TRM 450 through the user's product interface. (async @ 38400 w/8N1)
5. Enable the configuration mode for the TRM 450 radio. (Ground Pin 11 of the radio transceiver's DATA INTERFACE.) **DIAGNOSTICS OPEN** will appear on the terminal screen terminal once diagnostics communication with the radio is established.
6. Review the existing essential TRM 450 configuration parameters through a series of terminal commands.

- **MODEM—Data Configuration**

Response indicates:

Payload data rate (**BAUD**)

Gaussian Bandwidth x Data Rate (**BT**)

Channel Spacing (**BW**)

For example: **9.6Kbps BT=.5 25KHz.**

- **PWR—RF Power Output**

Responses: H = 2 Watts, L = 0.5 Watts

7. Check and set the radio transmit and receive frequencies.

---

**NOTE:** The operating frequencies are typically not set at the factory. Determine the transmit and receive frequencies to be used, and follow the steps below to program them. The TRM 450 must be programmed for the frequencies for which you hold a valid license and be within the radio's operating subband. (See Figure 4 on Page 11 for guidance in identifying the radio's operating band.)

---

- a. Set the transmit frequency with the **TX xxx.xxxxx** command.

Press **ENTER** after the command.



- b. Set the receive frequency with the **RX xxx.xxxxx** command.  
Press **ENTER** after the command.
  - c. After programming any parameter, **PROGRAMMED OK** will be displayed to indicate a successful entry.
8. Review and reprogram any other parameters as necessary to complement your system requirements. (See Table 5 on Page 19 for a list of all user commands.)
  9. Optimize the antenna installation by measuring the received signal strength of the other station with which this station will be communicating. Monitor the TRM 450's RSSI level. Rotate the station antenna until the signal is the strongest. The less negative the value, the stronger the incoming radio signal.  
  
The received signal should be at least  $-90$  dBm. This value will provide a safety margin (fade margin) to prevent loss of communications through signal reduction (fading) caused by weather conditions, changes in station location if mobile, or other obstructions temporarily positioned between communicating TRM 450 stations.
  10. Disconnect the terminal interface and the ground from Pin 11 from the DATA INTERFACE connector.
  11. Connect the data equipment to the transceiver's DATA INTERFACE connector and test for normal operation.

## 4.0 TROUBLESHOOTING

Successful troubleshooting of the radio system is not difficult, but it requires a logical approach. It is best to begin troubleshooting at the master station, as the rest of the system depends on the master for polling commands. If the master station has problems, the operation of the entire network can be compromised.

It is good practice to start by checking the simple things. For proper operation, all radios in the network must meet these basic requirements:

- Adequate and stable primary power.
- Secure connections (RF, data, and power).
- An efficient and properly aligned antenna system with a good received signal strength (at least  $-90$  dBm). It is possible for a system to operate with weaker signals, but reliability may be degraded.



- Proper programming of the transceiver’s operating parameters (see *Section 3.0, TRANSCIEVER CONFIGURATION AND DIAGNOSTIC COMMANDS*).
- The correct interface between the transceiver and the connected data equipment (correct cable wiring, proper data format, timing, etc.).

## 5.0 TECHNICAL REFERENCE

### 5.1 TRM 450 Transceiver Specifications

#### RADIO TYPE

---

Synthesized, half duplex, 6.25 and 5.0 kHz channel spacing, split frequency, or simplex

#### ENVIRONMENTAL

---

Temperature Range:	-30 to +60 degrees C
Humidity:	0 to 95% at 40 degrees C
Board Dimensions:	2.75" W x 0.4" H x 1.75" D 7.0 cm W x 1.10 cm H x 4.4 cm D
Weight:	x.x oz. (x.x kg)
Enclosure:	None. Open-frame PCB with digital/RF circuit shield

#### TRANSMITTER

---

Frequency Range:	410 – 430 MHz 430 – 450 MHz 450 – 470 MHz
Frequency Increments:	6.25 and 5.0 kHz
Frequency Stability:	1.5 ppm, -30 to +60 degrees C
Channel Spacing:	6.25 and 5.0 kHz
Modulation Type:	GMSK (Gaussian-mean Shift Keying)
Carrier Power:	0.5 W, 2 W programmable (+27 DBM, +33 dBm)
Duty Cycle:	50%
Output Impedance:	50 ohms
RF Connection:	Pads for SMT IMP 3 mm RF connector
Spurious and Harmonics:	-65 dBc
Transmitter Keying:	On reception of data
Key-up Time:	2 ms
Data Rate Over-the-Air :	4800, 8000, 9600, 16000, and 19200 bps (Rate user-selectable via BAUD command)

#### RECEIVER

---

Type:	Double conversion superheterodyne (45 MHz IF)
Frequency Range:	410 – 430 MHz 430 – 450 MHz 450 – 470 MHz
Frequency Increments:	6.25 kHz





Frequency Stability:	1.5 ppm, -30 to +60 degrees C
Spurious and Image Rejection:	-70 dB
Sensitivity:	12 dB SINAD @ -119 dBm @ 4800 bps 12 dB SINAD @ -116 dBm @ 19200 bps
Intermodulation Rejection:	-70 dB minimum
Selectivity:	60 dB typical at adjacent channel (EIA)
Bandwidth:	12.5 kHz

**DATA INTERFACE**

---

Connector:	AVX fine-pitch 5046 series
Signaling:	TTL
Data Rate—Diagnostics:	38400 bps asynchronous
Data Rate—Payload:	38400 bps synchronous
Flow-Control:	Synchronous serial with clock supplied by the radio in bursts of 8 bits (when the radio is ready)
Data Latency:	< 20 ms typical

**PRIMARY POWER**

---

Voltage:	3.3 Vdc (3.2-3.6) via Data Interface connector
RX Current at 3.3 Vdc (typical):	112 mA
TX Current at 3.3 Vdc (typical):	1.8 A @ high power (2W) 750 mA @ low power (0.5W)
Current Limit/Polarity Protection:	External; User-provided

**5.2 Test and Evaluation Assembly**

A PCB assembly (03-6053A02) is available from MDS to facilitate bench testing, programming and evaluation of the TRM 450 transceiver module. This module features:

- Mounting Posts for aligning and securing TRM 450 module
- 3.3 Vdc Power Input Receptacle
- 6-12 Vdc Power Input Receptacle
- DB-25 Data Interface (Female)  
providing EIA/RS-232 to TTL signalling conversion
- Radio Configuration Mode Enable (Manual Jumper)
- Activity LEDs:
  - TXD
  - RXD
  - TX CLOCK
  - RX CLOCK
  - CARRIER DETECT
  - TEST (Reserved)
- Antenna Connector—RF I/O (TNC)
- Receiver Analog Output through DB-25 interface connector



**NOTE:** The Test and Evaluation Assembly is not intended for service in a permanent installation in a user-designed product or system.

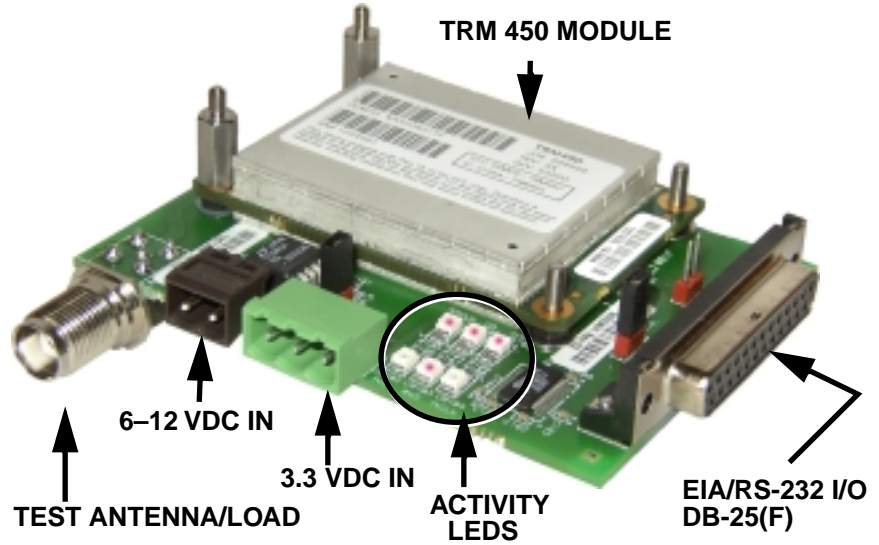

**Figure 10. Test and Evaluation PCB Assembly**  
(With TRM 450 module installed and retainers on RF connector end.)

**Table 6. DB-25 Interface Connector Pinouts**  
**Test and Evaluation PCB**

Pin Number	Input/Output	Pin Description
1	IN/OUT	<b>Ground</b> (Signal)
2	IN	<b>TX Data—Transmit Data</b> (payload) in normal operation
3	OUT	<b>RX Data—Receive Data</b> <ul style="list-style-type: none"> <li>• Receive data (off-the-air) in normal operation</li> <li>• Control data from the processor in setup mode</li> </ul>
4	OUT	<b>TX ON—Request to key radio transmitter</b> <ul style="list-style-type: none"> <li>• High puts radio in transmit mode</li> <li>• Low puts radio in receive mode</li> </ul>
5		
6		No connection
7	IN/OUT	<b>Ground</b> (Signal)
8	OUT	<b>CD—Carrier Detect</b> <ul style="list-style-type: none"> <li>• Low whenever RSSI exceeds the programmed CDR threshold.</li> <li>• Detects RF activity on the radio channel without consideration for the signals modulation type or protocol.</li> </ul>
9		Factory Test— Do not connect



**Table 6. DB-25 Interface Connector Pinouts  
Test and Evaluation PCB (Continued)**

Pin Number	Input/Output	Pin Description
10		No connection
11	OUT	<b>RX Audio—Filtered receive audio</b> <ul style="list-style-type: none"> <li>• For test purposes only</li> <li>• Also available through J109 (Pin 1 – Out, Pin 2 – GND)</li> </ul>
12	IN	<b>Shutdown</b> <ul style="list-style-type: none"> <li>• Low = Radio powered down (off-line)</li> </ul>
13	OUT	<b>RF synthesizer lock detect signal</b> <ul style="list-style-type: none"> <li>• High = locked (Radio ready for service)</li> <li>• Low = Out-of-lock (Radio disabled)</li> <li>• Raw / “unfiltered”</li> </ul>
14		No connection
15	OUT	<b>TX Clock—Transmit Data Clock</b> <ul style="list-style-type: none"> <li>• Only applicable when “<b>CLK TX</b>” is programmed and TX ON is asserted</li> <li>• Clock goes from low to high to request each new TXD bit</li> <li>• Continuously high when in Configuration Mode (J100, Pin 11 = Low), or when “<b>CLK RX</b>” is selected</li> </ul>
16		No connection
17	OUT	<b>RX Clock—Always applicable when receiving</b> <ul style="list-style-type: none"> <li>• Goes from low to high at the center of each RX Data bit (receive mode)</li> <li>• Provided when transmitting if “<b>CLK RX</b>” is programmed</li> <li>• Goes from low to high to request each new TXD bit</li> <li>• Continuously high when transceiver is in Configuration Mode (J100, Pin 11 = Low)</li> </ul>
18		Do not connect—Reserved for factory use only.
19		No connection
20		No connection



**Table 6. DB-25 Interface Connector Pinouts  
Test and Evaluation PCB (Continued)**

Pin Number	Input/Output	Pin Description
21	OUT	<b>RSSI—Receive Signal Strength Indicator</b> <ul style="list-style-type: none"> <li>Analog voltage between 0 and 3 Vdc proportional to signal strength on the channel</li> </ul>
22		No connection
23	IN	<b>CONFIG—Configure Radio</b> <ul style="list-style-type: none"> <li>High (unterminated) puts radio in normal payload mode to receive or transmit data at the programmed rate</li> <li>Low (Ground/J108 Jumpered) puts radio in setup mode to communicate with the processor at 38.4 kbps asynchronously</li> </ul>
24		No connection
25		No connection

### 5.3 Vendors for Connectors

The following are vendors of interface connectors that may be used on customer-designed interfaces or equipment connected to the TRM 450. These are not the only sources of these devices nor does this listing represent an endorsement by Microwave Data Systems.

#### Data Interface Connector



#### 30-Pin PCB SMT Receptacle, J100

MDS: 73-3463A12  
 AVX: 14-5046-030-630-829

#### 30-Pin PCB SMT Plug, Mates with J100

MDS: 73-3463A13  
 AVX: 24-5046-030-600-829

#### Vendor:

AVX Corporation  
 Web: [www.AVXcorp.com](http://www.AVXcorp.com)



## RF Coaxial Connector



### PCB SMT Connector

Mounted on user's mating PCB to make contact with TRM 450 RF pads J300/301

MDS: 73-1022A53

Radiall: R107.064.020

### Vendor:

Radiall SA  
 101 Rue Philibert Hoffmann  
 93116 Rosny Sous Bois  
 France

Tel: + 33 1 49 35 35 35

FAX: + 33 1 49 35 35 14

Web: [www.Radiall.com](http://www.Radiall.com)



### 5.4 dBm-Watts-Volts Conversion Chart

Table 7 is provided as a convenience for determining the equivalent wattage or voltage of an RF power expressed in dBm.

**Table 7. dBm-Watts-Volts Conversion—for 50 Ohm Systems**

<b>dBm</b>	<b>V</b>	<b>Po</b>	<b>dBm</b>	<b>V</b>	<b>Po</b>	<b>dBm</b>	<b>mV</b>	<b>Po</b>	<b>dBm</b>	<b>μV</b>	<b>Po</b>
+53	100.0	200W	0	.225	1.0mW	-49	0.80		-98	2.9	
+50	70.7	100W	-1	.200	.80mW	-50	0.71	.01μW	-99	2.51	
+49	64.0	80W	-2	.180	.64mW	-51	0.64		-100	2.25	.1pW
+48	58.0	64W	-3	.160	.50mW	-52	0.57		-101	2.0	
+47	50.0	50W	-4	.141	.40mW	-53	0.50		-102	1.8	
+46	44.5	40W	-5	.125	.32mW	-54	0.45		-103	1.6	
+45	40.0	32W	-6	.115	.25mW	-55	0.40		-104	1.41	
+44	32.5	25W	-7	.100	.20mW	-56	0.351		-105	1.27	
+43	32.0	20W	-8	.090	.16mW	-57	0.32		-106	1.18	
+42	28.0	16W	-9	.080	.125mW	-58	0.286				
+41	26.2	12.5W	-10	.071	.10mW	-59	0.251				
+40	22.5	10W	-11	.064		-60	0.225	.001μW	<b>dBm</b>	<b>nV</b>	<b>Po</b>
+39	20.0	8W	-12	.058		-61	0.200		-107	1000	
+38	18.0	6.4W	-13	.050		-62	0.180		-108	900	
+37	16.0	5W	-14	.045		-63	0.160		-109	800	
+36	14.1	4W	-15	.040		-64	0.141		-110	710	.01pW
+35	12.5	3.2W	-16	.0355					-111	640	
+34	11.5	2.5W				<b>dBm</b>	<b>μV</b>	<b>Po</b>	-112	580	
+33	10.0	2W	<b>dBm</b>	<b>mV</b>	<b>Po</b>	-65	128		-113	500	
+32	9.0	1.6W	-17	31.5		-66	115		-114	450	
+31	8.0	1.25W	-18	28.5		-67	100		-115	400	
+30	7.10	1.0W	-19	25.1		-68	90		-116	355	
+29	6.40	800mW	-20	22.5	.01mW	-69	80		-117	325	
+28	5.80	640mW	-21	20.0		-70	71	.1nW	-118	285	
+27	5.00	500mW	-22	17.9		-71	65		-119	251	.001pW
+26	4.45	400mW	-23	15.9		-72	58		-120	225	
+25	4.00	320mW	-24	14.1		-73	50		-121	200	
+24	3.55	250mW	-25	12.8		-74	45		-122	180	
+23	3.20	200mW	-26	11.5		-75	40		-123	160	
+22	2.80	160mW	-27	10.0		-76	35		-124	141	
+21	2.52	125mW	-28	8.9		-77	32		-125	128	
+20	2.25	100mW	-29	8.0		-78	29		-126	117	
+19	2.00	80mW	-30	7.1	.001mW	-79	25		-127	100	
+18	1.80	64mW	-31	6.25		-80	22.5	.01nW	-128	90	
+17	1.60	50mW	-32	5.8		-81	20.0		-129	80	.1fW
+16	1.41	40mW	-33	5.0		-82	18.0		-130	71	
+15	1.25	32mW	-34	4.5		-83	16.0		-131	61	
+14	1.15	25mW	-35	4.0		-84	11.1		-132	58	
+13	1.00	20mW	-36	3.5		-85	11.1		-133	50	
+12	.90	16mW	-37	3.2		-86	11.5		-134	45	
+11	.80	12.5mW	-38	2.85		-87	10.0		-135	40	
+10	.71	10mW	-39	2.5		-88	9.0		-136	35	
+9	.64	8mW	-40	2.25	.1μW	-89	8.0		-137	33	
+8	.58	6.4mW	-41	2.0		-90	7.1	.001nW	-138	29	
+7	.500	5mW	-42	1.8		-91	6.1		-139	25	
+6	.445	4mW	-43	1.6		-92	5.75		-140	23	.01fW
+5	.400	3.2mW	-44	1.4		-93	5.0				
+4	.355	2.5mW	-45	1.25		-94	4.5				
+3	.320	2.0mW	-46	1.18		-95	4.0				
+2	.280	1.6mW	-47	1.00		-96	3.51				
+1	.252	1.25mW	-48	0.90		-97	3.2				



## 6.0 GLOSSARY OF TERMS

If you are new to digital radio systems, some of the terms used in this guide may be unfamiliar. The following glossary explains many of these terms and is helpful in understanding the operation of the transceiver.

**Antenna System Gain**—A figure, normally expressed in dB, representing the power increase resulting from the use of a gain-type antenna. System losses (from the feedline and coaxial connectors, for example) are subtracted from this figure to calculate the total antenna system gain.

**Bit**—The smallest unit of digital data, often represented by a one or a zero. Eight bits (plus start, stop, and parity bits) usually comprise a byte.

**Bits-per-second**—See *BPS*.

**BPS**—Bits-per-second. A measure of the information transfer rate of digital data across a communication channel.

**Byte**—A string of digital data usually made up of eight data bits and start, stop and parity bits.

**Data Circuit-terminating Equipment**—See *DCE*.

**Data Communications Equipment**—See *DCE*.

**Data Terminal Equipment**—See *DTE*.

**dBi**—Decibels referenced to an “ideal” isotropic radiator in free space. Frequently used to express antenna gain.

**dBm**—Decibels referenced to one milliwatt. An absolute unit used to measure signal power, as in transmitter power output, or received signal strength.

**DCE**—Data Circuit-terminating Equipment (or Data Communications Equipment). In data communications terminology, this is the “modem” side of a computer-to-modem connection. The MDS TRM 450 is a DCE device.

**Decibel (dB)**—A measure computed from the ratio between two signal levels. Frequently used to express the gain (or loss) of a system.

**DTE**—Data Terminal Equipment. A device that provides data in the form of digital signals at its output. Connects to the DCE device.

**ETSI**—European Telecommunications Standards Institute. A non-profit group that produces and approves standards for use throughout Europe and other locations pertaining to communications equipment and systems.

**Fade Margin**—The greatest tolerable reduction in average received signal strength that is anticipated under most conditions. Provides an allowance for reduced signal strength due to multipath, slight antenna movement, or changing atmospheric losses. A fade margin of 20 is usually sufficient in most systems.

**Gaussian-Mean Shift Keying (GMSK) Modulation**—A form of continuous-phase FSK, in which the phase is changed between bits to provide a constant envelope.

**Hardware Flow Control**—A transceiver feature used to prevent data buffer overruns when handling high-speed data from the RTU or PLC. When the buffer approaches overflow, the radio drops the clear-to-send (CTS) line, which instructs the RTU or PLC to delay further transmission until CTS again returns to the high state.

**Host Computer**—The computer installed at the master station site, which controls the collection of data from one or more remote sites.

**Latency**—The delay (usually expressed in milliseconds) between when data is applied to TXD (Pin 2) at one radio, until it appears at RXD (Pin 3) at the other radio.

**MAS**—Multiple Address System. A radio system where a central master station communicates with several remote stations for the purpose of gathering telemetry data.

**Master (Station)**—Radio which is connected to the host computer. It is the point at which polling enters the network.

**Multiple Address System**—See *MAS*.

**PLC**—Programmable Logic Controller. A dedicated microprocessor configured for a specific application with discrete inputs and outputs. It can serve as a host or as an RTU.

**Point-to-Multipoint System**—A radio communications network or system designed with a central control station that exchanges data with a number of remote locations equipped with terminal equipment.

**Poll**—A request for data issued from the host computer (or master PLC) to a remote radio.

**Programmable Logic Controller**—See *PLC*.

**Received Signal Strength Indication**—See *RSSI*.

**Redundant Operation**—A station arrangement where *two* transceivers and two power supplies are available for operation, with automatic switchover in case of a failure.





**Remote (Station)**—A radio in a network that communicates with an associated master station.

**Remote Terminal Unit**—See *RTU*.

**RSSI**—Received Signal Strength Indication. A measure, in dBm, of the strength of the signal received by a radio from an antenna. The radio must be properly calibrated for the RSSI value to be meaningful.

**RTU**—Remote Terminal Unit. A data collection device installed at a remote radio site.

**SCADA**—Supervisory Control And Data Acquisition. An overall term for the functions commonly provided through an MAS radio system.

**Supervisory Control And Data Acquisition**—See *SCADA*.



# IN CASE OF DIFFICULTY...

---

MDS products are designed for long life and trouble-free operation. However, this equipment, as with all electronic equipment may have an occasional component failure. The following information will assist you in the event that servicing becomes necessary.

## FACTORY TECHNICAL ASSISTANCE

---

Technical assistance for MDS products is available from our Customer Support Team during business hours (8:00 A.M.–5:30 P.M. Eastern Time). When calling, please give the complete model number of the radio, along with a description of the trouble symptom(s) that you are experiencing. In many cases, problems can be resolved over the telephone, without the need for returning the unit to the factory.

Please use the following telephone numbers for product assistance:

716-242-9600 (Phone)

716-242-9620 (Fax)

## FACTORY REPAIRS

---

Component-level repair of radio equipment is *not* recommended in the field. Many components are installed using surface mount technology, which requires specialized training and equipment for proper servicing. For this reason, the equipment should be returned to the factory for any PC board repairs. The factory is best equipped to diagnose, repair and align your radio to its proper operating specifications.

If return of the equipment is necessary, you will be issued a Returned Material Authorization (RMA) number. The RMA number will help expedite the repair so that the equipment can be repaired and returned to you as quickly as possible. Please be sure to include the RMA number on the outside of the shipping box, and on any correspondence relating to the repair. *No equipment will be accepted for repair without an RMA number.*

A statement should accompany the radio describing, in detail, the trouble symptom(s), and a description of any associated equipment normally connected to the radio. It is also important to include the name and telephone number of a person in your organization who can be contacted if additional information is required.

The radio must be properly packed for return to the factory. The original shipping container and packaging materials should be used whenever possible. All factory returns should be addressed to:

Microwave Data Systems Inc.  
Customer Service Department  
(RMA No. XXXX)  
175 Science Parkway  
Rochester, NY 14620 USA

When repairs have been completed, the equipment will be returned to you by the same shipping method used to send it to the factory. Please specify if you wish to make different shipping arrangements.

**industrial/wireless/performance**



175 Science Parkway, Rochester, New York 14620  
General Business: +1 (585) 242-9600  
FAX: +1 (585) 242-9620  
Web: [www.microwavedata.com](http://www.microwavedata.com)