



RCL220 Radio Module

Module Integration Guide

Revision 1.0

Prepared by: [GE MDS Engineering Team](#)

17-JULY-2023



GE Renewable Energy
GE MDS LLC

Table of Contents

General Description	2
Specifications	3
Table 1: RCL220 Module Specifications	3
Hardware Dimensions.....	4
Interface Specification	5
Application Information: Radio Network operation.....	6
<i>Note about terminology used</i>	6
LCU-OCU Direct Mode (No Repeaters)	6
LCU-OCU Mode with Coordinating Repeater	7
Multiple LCU-OCU with Multiple Repeaters	8
User Interface	9
Regulatory Information for Limited Modular Use	12
Applicable FCC Rules	12
Operational use conditions	12
Limited Module Host restrictions	12
Trace antenna designs	12
RF exposure considerations	12
Antennas	12
Labeling and Compliance	13
Test Modes.....	13
Additional testing for Part 15 Subpart B	13
EMI Considerations	13
Changes.....	14
Process for FCC Compliance of RCL220 Installed in Host	15
Receiver sDoC Procedure.....	15
Transmitter Conducted Emissions Assessment	15
Transmitter Radiated Emissions Assessment	16

General Description

The Association of American Railroads has established a specification for the remote control of locomotives. The Remote-Control Locomotive (RCL) protocol is transmitted wirelessly from external control points to the locomotive. GE MDS is providing the equipment that provides the wireless physical layers over which the RCL communication protocol is shared in the 220MHz band.

The RCL220 Radio Module is shown in Figure 1, Below. This module is in a form factor approximately 4"x2"x0.5", has a 52-pin card edge connector for data/power interface, and a TNC connector for the antenna connection.

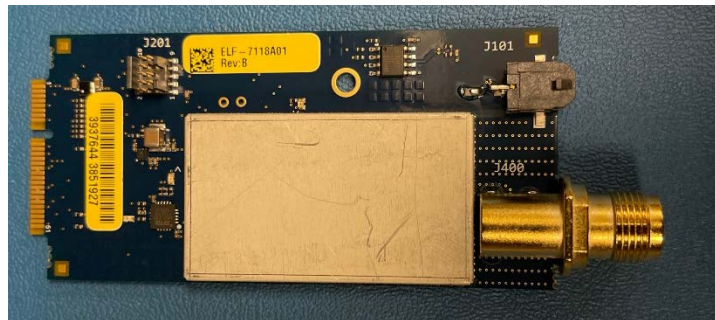

Figure 1: RCL220 Radio Module

This module is designed for installation only in the GE MDS Orbit MCR chassis as shown in Figure 2, below.



Figure 2: GE MDS Orbit MCR (Left) and ECR (Right) form factors.

The Orbit MCR host supplies regulated 5.25V power for operation of this module, serial interfaces for payload and diagnostics, and an USB interface that is used for updating the module firmware.

Specifications

Table 1: RCL220 Module Specifications

Description:	220MHz Railroad Communications Module
Manufacturer:	GE MDS, LLC 175 Science Parkway Rochester, NY 14620 USA
Operating Frequency Range:	217-222MHz (Transmit) 217-222MHz (Receive)
Applicable Regulations:	FCC CFR47 Part 90 (217-222MHz) ISED RSS-119 (217-220MHz)
Output Power:	+33dBm
Modulation:	GMSK, Bandwidth Time = 0.3, 9615bps
Bandwidth:	12.5kHz
Channel Spacing:	12.5kHz
Transmitter Architecture:	Synthesized Direct Conversion
Receiver Architecture:	Synthesized Direct Conversion
Reference Clock:	39MHz, 0.5ppm
RF Interface:	TNC (Female) for Tx/Rx functions
Data Interface:	52-pin Card Edge connector provides: USB (Maintenance/Firmware updates) Serial (Diagnostics/Configuration) Serial (Payload data)
Operating Temperature Range:	-40 to +70C
Module Operating Voltage:	5.25VDC (Supplied through edge connector)
Module Operating Current:	2.0A (At maximum TX RF power operation)
Module Dimensions:	3.4"x1.6"x0.4"

Hardware Dimensions

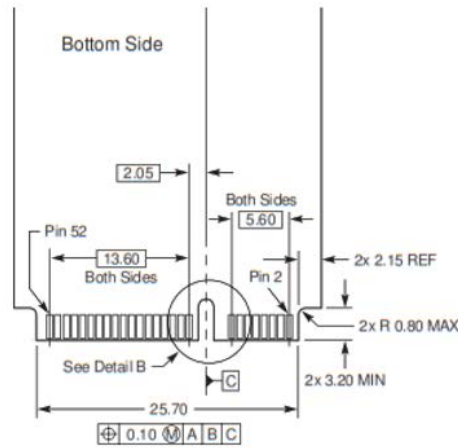
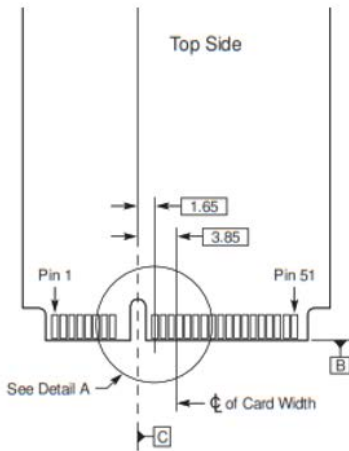
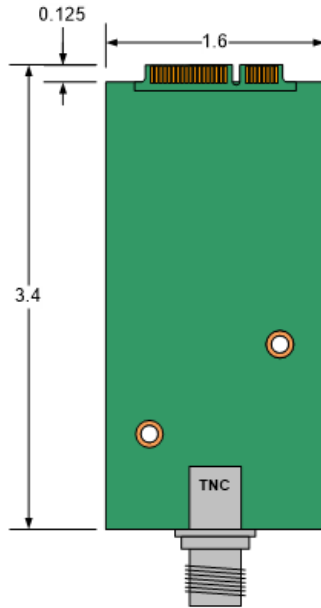

Heatsink Detail

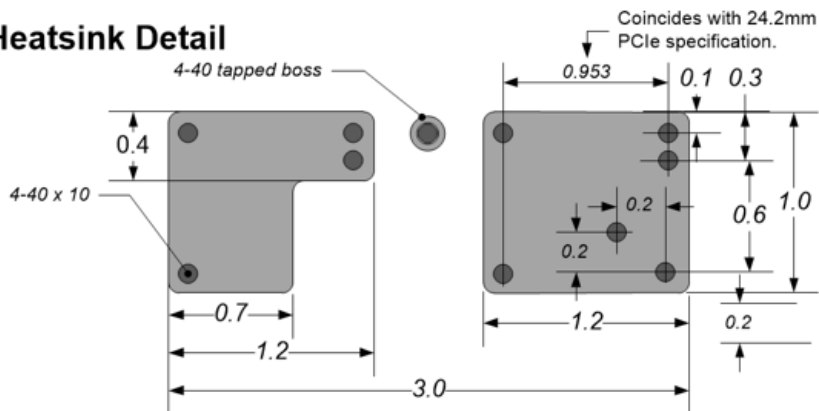

Interface Specification

The 52pin Host interface pinout is as shown in Table 2, Below.

52-Pin Card Edge Fingers			
Top Side		Bottom Side	
Pin	Symbol	Pin	Symbol
1	No Connect	2	V_NIC
3	NIC2NIC_RXD	4	GND
5	NIC2NIC_TXD	6	JTDI
7	JTMS	8	No Connect
9	GND	10	JTDO
11	No Connect	12	JTCK
13	No Connect	14	~JTRST
15	GND	16	SYNC/PPS_IN
17	No Connect	18	GND
19	R_VSET	20	~RESET
21	GND	22	No Connect
23	No Connect	24	V_NIC
25	No Connect	26	GND
27	GND	28	NIC_TXD
29	GND	30	NIC_RXD
31	No Connect	32	USB_VBUS
33	No Connect	34	GND
35	GND	36	USB1_D-
37	GND	38	USB1_D+
39	V_NIC	40	GND
41	V_NIC	42	~ROR_NIC_LED
43	GND	44	GPIO4/CYA
45	No Connect	46	NIC_ID
47	No Connect	48	GPIO1/BOOT
49	GPIO2/DSP_Alarm	50	GND
51	GPIO3/LCP	52	V_NIC

Table 2: Host Interface Pinout

Application Information: Radio Network operation

The RCL220 is a half-duplex radio module designed for use in TDMA RCL networks. The unit is designed for installation in the Operator Control Unit (OCU) to communicate with other radio products in a railyard, including locomotive (Locomotive Control Unit, or LCU) or Repeaters.

This product is configured with a list of TX and RX frequency pairs that are entered by an authorized representative of the railroad communications team. The frequencies are scanned in receive mode until a reliable RF link is found.

Note about terminology used

The frequency hopping referred to within this document is not a form of spread spectrum, but rather a method the railroad spectrum licensee uses to automatically chose other frequency pairs they have been assigned when a channel is congested and/or has poor signal conditions to sustain reliable communications. The system will step through two frequency pairs in four seconds.

Repeaters in the railyard are devices that can receive transmissions from LCU or OCU radios, demodulate the data, interpret the payload, and transmit new data to the LCU or OCU radios if needed. The term repeater in this sense is different than the repeaters classified by the FCC or ISED.

LCU-OCU Direct Mode (No Repeaters)

In its simplest form the RCL system can operate in a standalone fashion with no repeaters present. Prior to on-air deployment, an off-line configuration is required at which time the two OCUs are “paired” to their LCU. This initialization ensures that only the two pre-defined OCUs can communicate with and control the LCU. After initialization, when the units go live in the yard they will operate in Distributed Coordination Mode, also known as Direct Mode, and the wireless communication between the devices is done with a TDMA time slot channel changing scheme.

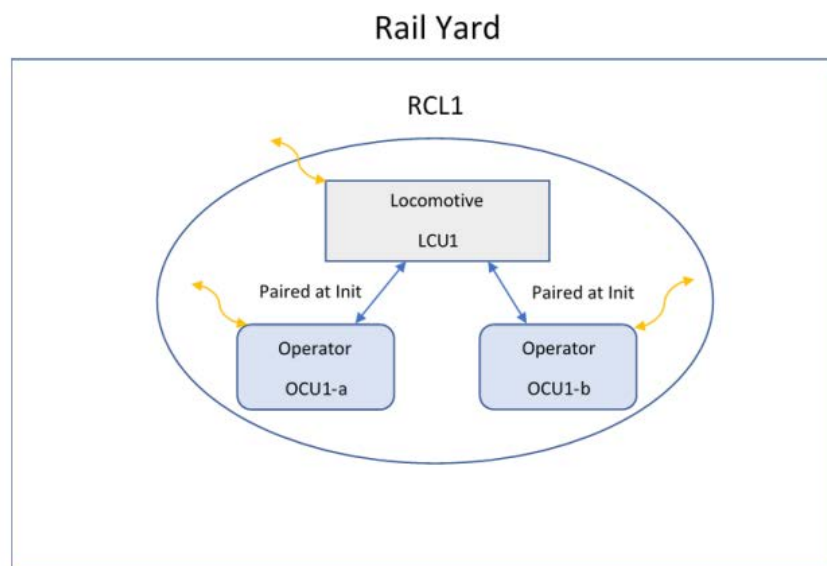

Figure 4: LCU-OCU Direct Mode

LCU-OCU Mode with Coordinating Repeater

The system contains one Repeater which is configured in Coordinator mode. The LCU / OCUs are paired ahead just like in the Single-RCL use case, they boot into the slot-hopped DCM and establish communication with each other. Simultaneously, LCU discovers and establish communication with the coordinator and when the Distributed Coordination Mode (DCM) exit criteria are met, the LCU drives the system to switch to the Centralized Coordination Mode (CCM) which is controlled by the Coordinator. In CCM the timeslots allocated to the individual RCL systems in the yard is done intelligently by the Coordinator to prevent over-the-air packet collisions. This use case is also advantageous in that the overall wireless coverage is improved by having the secondary path between the LCU and OCUs that goes through the Coordinator.

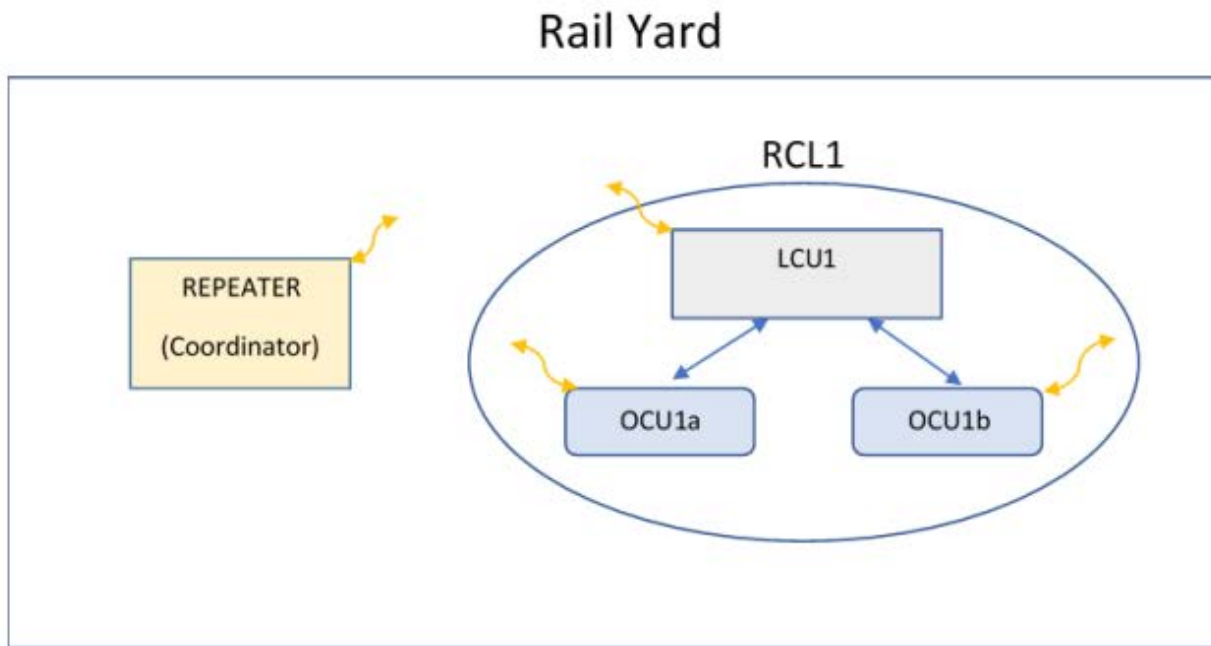

Figure 5: LCU-OCU Mode with Repeater

Multiple LCU-OCU with Multiple Repeaters

The system contains one Repeater which runs in Coordinator mode and one or more additional Repeaters acting as Satellites. The Coordinator and Satellites are linked together via a high-speed backbone on Ethernet, fiber, or highspeed wireless. The system behaves the same as the Single-Repeater Use Case with one exception: all the wireless data packets received by the Repeaters are shared on the backbone. With the sharing of the packets across all the Repeaters the control algorithm can determine which Repeater is best to re-transmit to each OCU or LCU in the yard, resulting in the optimal coverage/communication scenario for the overall system.

Rail Yard

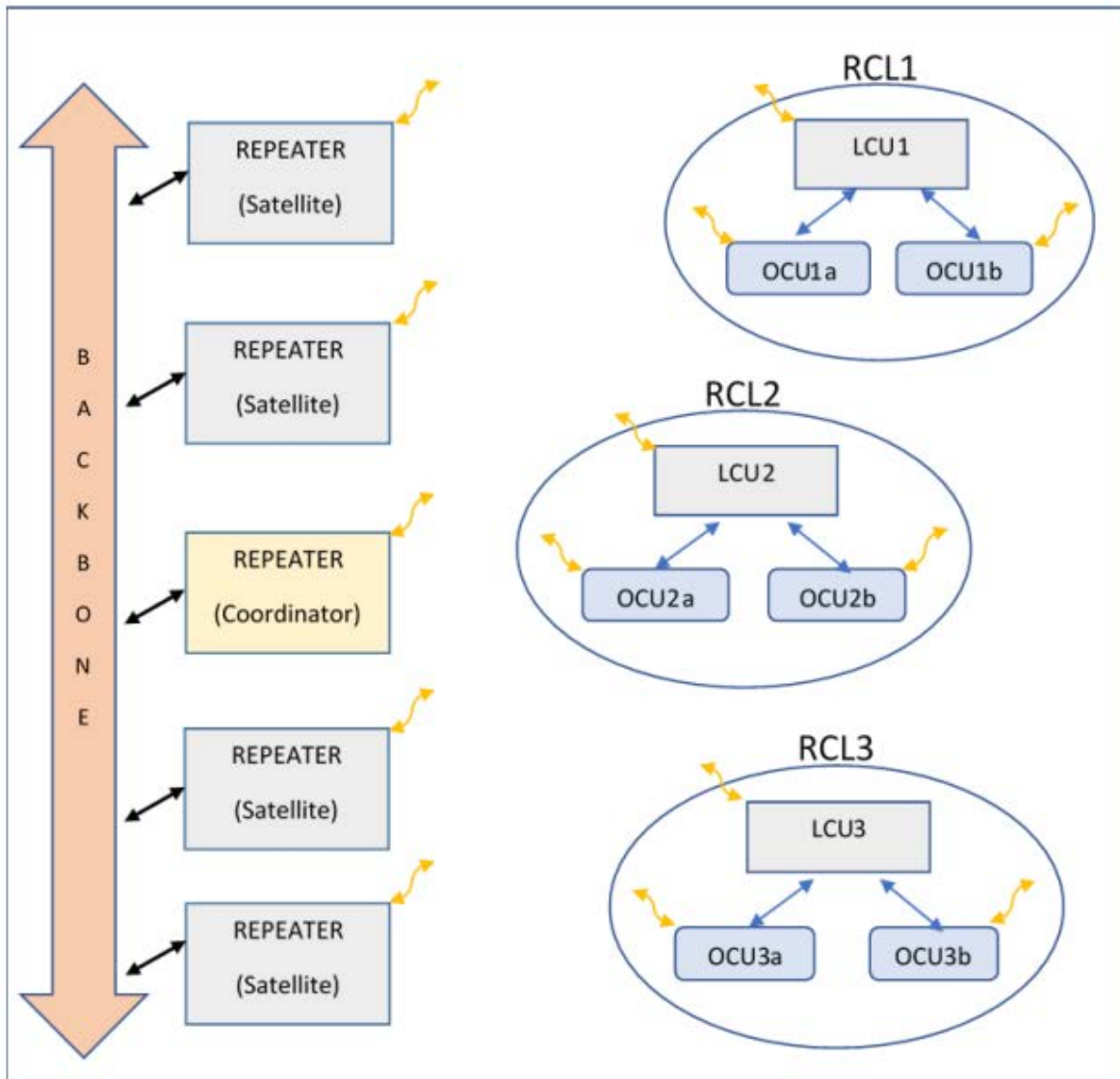

Figure 6: Multiple LCU-OCU Mode with Multiple Repeaters

User Interface

The Orbit MCR Host provides a command line interface on the COM2 port for radio configuration. Figure 7, below, shows the command line interface port of the Orbit MCR. Use baud 115200, 8-N-1.



Figure 7: COM2 CLI (Command Line Interface) port for RCL220 inside of the Orbit MCR Host

- SREV [TIME] Display MCU (TI) software revision. Entering the optional time argument causes a build timestamp to be displayed.
- PASS xxxx By entering a password additional engineering and factory only commands may be used.
- RX xxx.xxxxx This sets the receive frequency used in test mode. Up to 5 digits can be entered after the decimal point, but trailing zeros do not have to be entered. Range checking is not performed.
- TX xxx.xxxxx This sets the transmit frequency used in test mode. Up to 5 digits can be entered after the decimal point, but trailing zeros do not have to be entered. Range checking is not performed.
- MFREQ1 xxx.xxxxx
BFREQ1 xxx.xxxxx
MFREQ2 xxx.xxxxx
BFREQ2 xxx.xxxxx
MFREQ3 xxx.xxxxx
BFREQ3 xxx.xxxxx
MFREQ4 xxx.xxxxx
BFREQ4 xxx.xxxxx
- These commands set the corresponding receive & transmit frequency pair used as specified by the DSP (mac controller). Up to 5 digits can be entered after the decimal point, but trailing zeros do not have to be entered. Range checking is not performed.

RCL220: Module Integration Guide

PWR x	This sets the transceivers output power. Valid options are H , L , and XL , for “high”, “low”, and “extra low” power settings, respectively. (At calibration time, “H” is normally associated with 2 watts, and “L” is normally associated with 0.5 watts, and “XL” is associated with FPWR 1).
KEY	This is a test command that allows the user to unconditionally key the radio for test purposes.
KEYR	Key the radio with random data for test purposes.
TONEKEY	Key the radio unmodulated for test purposes.
DKEY	This is a test command that cancels the affect of a previous KEY command.
MODEM	This displays the current modem configuration. (Normally BAUD 9600, BT=.3, BW=12.5KHz). This can be used to determine if a modem test configuration is in effect (i.e., tones or analog operation).
SER	This displays the serial number of the radio (separate versions of this command exist for MCU & DSP)
RSSI	This causes the receiver to output the current value of RSSI. The output range is –50 dBm (strongest signal) to –120 dBm (no signal).
RSSI ON	This causes the receiver to output the current value of RSSI once every 3 seconds.
RSSI OFF	Turns off the continuous RSSI reading
ATTN (ON/OFF)	This puts the LNA in low gain mode (ON) or normal gain mode (OFF)
HELP	Displays this list of commands
PROG	This initiates a procedure to reprogram the FLASH memory for the radio.
INIT	This resets some common user programmable settings to the factory default. <ul style="list-style-type: none">• MODEM BAUD=9600, BT=.3, BW=12.5KHz• RX 220.00000 MHz• TX 220.00000 MHz• BFREQ1 221.10625 MHz• MFREQ1 220.106250 MHz• BFREQ2 221.11875 MHz• MFREQ2 220.11875 MHz• PWR=H• CAL DEV 40• POLL STARTUP OFF
IIEP	This resets all non-volatile memory. The radio will require factory recalibration.
MM xxxx	Used to directly view or modify a memory location.

RCL220: Module Integration Guide

ALARM	Returns a 4-digit hexadecimal alarm code. 0x8000 = Out-of-Lock 0x4000 = Not Calibrated
FPWR xxx	This is used to adjust output power. The valid range is 0 to 4096.
CPWR x	This is used to associate the current output power with a pre-programmed PWR command setting. Valid options are H and L, for “high” and “low” power settings, respectively.
RSSL	Used to calibrate the RSSI while injecting a Low signal level (-90 dBm).
RSSH	Used to calibrate the RSSI while injecting a High signal level (-70 dBm).
CAL CF xxxx	This allows calibration of the Center Frequency. The digits xxxx are in the range of –32767 to 32767 and represent a correction to be added to the operating frequency. (Not in Hertz)

Regulatory Information for Limited Modular Use

Applicable FCC Rules

This module is designed as a Part 90 device operating in the 217-222MHz band as detailed in Table 1: RCL220 Module Specifications.

WARNING: Any changes or modifications to the module not expressly approved by party responsible for compliance (GE MDS, LLC) could void the user’s authority to operate the equipment.

Operational use conditions

This module may only be used with the GE MDS Orbit MCR Chassis. This module is intended for use in locomotive applications. This product is designed for operation from -40 to +70C and is not intended for outdoor use. This device is for professional installation only. Output power is configurable up to +33dBm and must be adjusted to accommodate for antenna gain to conform to the specific ERP limits of the FCC licensee using this product.

Limited Module Host restrictions

The RCL220 radio module features a unique board to board connector and requires limited supply voltage and heatsinking provided by the Orbit MCR chassis.

Trace antenna designs

The RCL220 does not include any trace antenna designs, and therefore there are no applicable considerations for this topic.

RF exposure considerations

The radio equipment described in this operation emits radio frequency energy. The concentrated energy from a directional antenna may pose a health hazard. Persons may not come closer than 44 centimeters to the front of the antenna when the transmitter is operating with a 2.0dBi antenna and configured for +33dBm output power.

Antennas

The conducted output power of the module installed in the host chassis is up to +33dBm. This module is intended for professional installation only for integration into the GE MDS Orbit MCR host. The antennas that have been tested and approved for use with this module are as listed in Table 3, below.

Manufacturer	Model	Type	Gain
PCTEL	BMAXMFTS	Omnidirectional	0.0dBi
PCTEL	PCT-RSA-20	Omnidirectional	2.0dBi
Sinclair	ST221-SfeNF	Omnidirectional	2.12dBi
Sti-Co	HDLP-NB-220	Omnidirectional	2.12dBi

Table 3: Antennas tested with the RCL220 Module

Labeling and Compliance

Figure 8, below, is an example of the label that must be present on the Host: Orbit MCR as shown in Figure 9. This label is installed at the GE MDS factory during production.

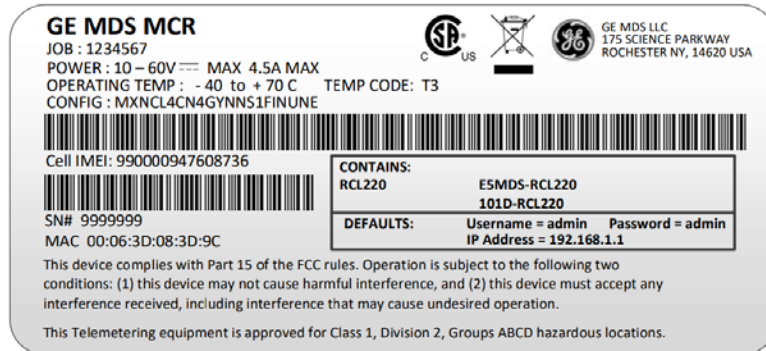

Figure 8, above: Orbit MCR Label showing “Contains E5MDS-RCL220, 101D-RCL220”



Figure 9: Location of label detailed in Figure 8, placed on the underside of the Orbit MCR

Test Modes

The Orbit MCR Host does not externalize module operational test modes to the end user. Test and alignment are performed during production calibration. Prior to product shipment, GE MDS performs a series of tests in the production environment to ensure that the completed assembly is operating satisfactorily.

Additional testing for Part 15 Subpart B

The Orbit MCR is the only permissible host for the GE MDS RCL220 Module. GE MDS must test and ensure that the MCR host complies with FCC Part 15 Subpart B when operating with the RCL220 radio module in place.

EMI Considerations

The RCL220 Radio Module includes integrated shielding for the RF section. This module conforms to all applicable Part 15 and Part 90 requirements without needing to be installed inside of the host.

enclosure. The Orbit MCR host does not allow multiple modules (Cellular and 220MHz) to operate simultaneously,

Changes

GE MDS does not offer for sale the RCL220 as a standalone device for integration with other hosts. As the grantee of the host and this module, GE MDS does not have any offer guidance or technical contacts to enable third party entities to create such products.

Process for FCC Compliance of RCL220 Installed in Host

This section describes the procedure for ensuring that full compliance of the RCL220 Module is maintained when installed in the Orbit MCR Host. The module is evaluated inside of the Orbit MCR using the sDoC procedure established by the FCC for the receiver. The steps below additionally identify a process to assess Transmit and conducted and radiated emissions when the RCL220 Module is operating at its lowest and highest frequencies, and highest transmitter power setpoint when installed in the host. The transmitter assessment steps ensure no degradation of transmitter performance when operating in the host.

1. Install RCL220 Radio Module into the MCR Chassis per the “Module Integration Instructions” section of this document.
2. Attach the appropriate power source to the Orbit MCR: DC 10-60V, 12W minimum.
3. Connect a PC to the Orbit MCR COM2 port for configuration of the RCL220 module for testing purposes.
4. Log in to the EUT using factory login username and password.

Receiver sDoC Procedure

Unintentional emissions of the RCL220 shall be performed on the module when it is installed in the Orbit MCR. The end product is tested as a complete assembly with module installed. Performance is evaluated at the lowest, middle, and highest receive frequencies and evaluated against Part 15.109 using the 2.15dBi Omnidirectional antenna. Conducted emissions are performed using the conducted antenna port test per Part 15.111.

1. The EUT, when powered on, immediately enters receive mode. Commands to change RX frequency are required to complete the evaluation of the end product in receive mode.
2. Configure receiver to lowest frequency (command `rx 217`)
3. Perform radiated/conducted emissions testing
4. Repeat steps 2,3 at the middle frequency (command `rx 219`)
5. Repeat steps 2,3 at the highest receive frequency (command `rx 222`)

GE MDS shall generate a Supplier’s Declaration of Conformity sDoC declaring conformance of the unintentional radiator (receiver emissions) to FCC standards.

GE MDS Orbit MCR is to provide instructions for RF exposure information to end users from page 12.

Transmitter Conducted Emissions Assessment

1. Attach a spectrum analyzer to the EUT Transmit Antenna port. Ensure proper attenuation is present for +33dBm without sustaining damage. Spectrum analyzer should be configured for the same RBW, VBW, and Sweep Time, Start, and Stop frequencies as the Part 90 and Part 15 FCC Test Data results published in the RCL220 reports.
2. Configure transmitter power to +33dBm (command `pwr hi`)
3. Configure transmitter to lowest frequency (command `tx 217`)
4. Key the transmitter (command `key`)

5. Record the results for Conducted TX 217MHz.
6. Analyze the results to ensure that no new conducted spurious emissions exist, and that no existing spurious emissions are greater than the values obtained in the modular test reports.
7. Repeat steps 3, 4, 5, 6 at the highest frequency (command `tx 222`)

Transmitter Radiated Emissions Assessment

1. This testing must be performed in an Anechoic Chamber. A spectrum analyzer should be configured for the same RBW, VBW, and Sweep Time, Start, and Stop frequencies as the Part 90 and Part 15 FCC Test Data results published in the RCL220 reports. Radiated Emissions tests are performed with both vertical and horizontal polarizations and 360-degree turntable. The original unintentional radiated emissions results are repeated with the RCL220 Module installed in the Orbit MCR.
2. Terminate the Transmitter antenna port using a 50-ohm load with a minimum power handling capability of 2W.
3. Configure transmitter power to +33dBm (command `pwr hi`)
4. Configure transmitter to lowest frequency (command `tx 217`)
5. Key the transmitter (command `key`)
6. Record the results for Conducted TX 217MHz.
7. Analyze the results to ensure that no new conducted spurious emissions exist, and that no existing spurious emissions are greater than the values obtained in the modular test reports.
8. Repeat steps 3, 4, 5, 6 at the highest frequency (command `tx 222`)