

# ENGINEERING TEST REPORT

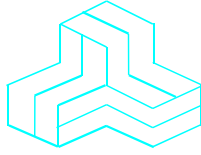

**INET**  
**Model No.: INET900**

**FCC ID: E5MDS-NH900**

*Applicant:*

**Microwave Data Systems Inc.**  
**175 Science Parkway**  
**Rochester, NY**  
**USA, 14620**

*In Accordance With*

**FEDERAL COMMUNICATIONS COMMISSION (FCC)**  
**PART 15, SUBPART C, SECTION 15.247**  
**Frequency Hopping Spread Spectrum Transmitters**  
**Operating in the Frequency band 902.5 - 927.5035 MHz**

**UltraTech's File No.: MIC-081F15C247**

This Test report is Issued under the Authority of  
Tri M. Luu, Professional Engineer,  
Vice President of Engineering  
UltraTech Group of Labs



Date: December 5, 2002

Report Prepared by: Dan Huynh

Tested by: Mr. Hung Trinh, EMI/RFI  
Technician

Issued Date: December 5, 2002

Test Dates: November 13-14, 2002

- *The results in this Test Report apply only to the sample(s) tested, and the sample tested is randomly selected.*
- *This report must not be used by the client to claim product endorsement by NVLAP or any agency of the US Government.*

## UltraTech

3000 Bristol Circle, Oakville, Ontario, Canada, L6H 6G4  
Tel.: (905) 829-1570 Fax.: (905) 829-8050

Website: [www.ultratech-labs.com](http://www.ultratech-labs.com), Email: [vic@ultratech-labs.com](mailto:vic@ultratech-labs.com), Email: [tri@ultratech-labs.com](mailto:tri@ultratech-labs.com)

  
31040/SIT

  
C-1376

  
46390-2049

  
200093-0

  
00-034





## TABLE OF CONTENTS

<b>EXHIBIT 1.</b>	<b>SUBMITTAL CHECK LIST.....</b>	<b>1</b>
<b>EXHIBIT 2.</b>	<b>INTRODUCTION .....</b>	<b>2</b>
2.1.	SCOPE.....	2
2.2.	RELATED SUBMITTAL(S)/GRANT(S).....	2
2.3.	NORMATIVE REFERENCES .....	2
<b>EXHIBIT 3.</b>	<b>PERFORMANCE ASSESSMENT .....</b>	<b>3</b>
3.1.	CLIENT INFORMATION .....	3
3.2.	EQUIPMENT UNDER TEST (EUT) INFORMATION.....	3
3.3.	EUT’S TECHNICAL SPECIFICATIONS.....	4
3.4.	PERMISSIVE CHANGES MADE IN CERTIFICATED EQUIPMENT .....	4
3.5.	LIST OF EUT’S PORTS .....	5
3.6.	ANCILLARY EQUIPMENT .....	5
<b>EXHIBIT 4.</b>	<b>EUT OPERATING CONDITIONS AND CONFIGURATIONS DURING TESTS.....</b>	<b>6</b>
4.1.	CLIMATE TEST CONDITIONS .....	6
4.2.	OPERATIONAL TEST CONDITIONS & ARRANGEMENT FOR TESTS .....	6
<b>EXHIBIT 5.</b>	<b>SUMMARY OF TEST RESULTS .....</b>	<b>7</b>
5.1.	LOCATION OF TESTS .....	7
5.2.	APPLICABILITY & SUMMARY OF EMC EMISSION TEST RESULTS .....	7
5.3.	MODIFICATIONS INCORPORATED IN THE EUT FOR COMPLIANCE PURPOSES .....	7
<b>EXHIBIT 6.</b>	<b>MEASUREMENTS, EXAMINATIONS &amp; TEST DATA FOR EMC EMISSIONS.....</b>	<b>8</b>
6.1.	TEST PROCEDURES .....	8
6.2.	MEASUREMENT UNCERTAINTIES .....	8
6.3.	MEASUREMENT EQUIPMENT USED.....	8
6.4.	ESSENTIAL/PRIMARY FUNCTIONS AS DECLARED BY THE MANUFACTURER.....	8
6.5.	COMPLIANCE WITH FCC PART 15 – GENERAL TECHNICAL REQUIREMENTS.....	9
6.6.	HOPPING CHANNEL CARRIER FREQUENCY CHARACTERISTICS [47 CFR §§ 15.247(A)(1) & (A)(1)(I)].....	13
6.6.1.	<i>Limits</i> .....	13
6.6.2.	<i>Method of Measurements</i> .....	13
6.6.3.	<i>Test Arrangement</i> .....	14
6.6.4.	<i>Test Equipment List</i> .....	14
6.6.5.	<i>Test data</i> .....	15
6.7.	PEAK OUTPUT POWER & EQUIVALENT ISOTROPIC RADIATED POWER (EIRP) [47 CFR § 15.247(B)] .....	16
6.7.1.	<i>Limits</i> .....	16
6.7.2.	<i>Method of Measurements</i> .....	16
6.7.3.	<i>Test Arrangement</i> .....	16
6.7.4.	<i>Test Equipment List</i> .....	16
6.7.5.	<i>Test Data</i> .....	17
6.8.	RF EXPOSURE REQUIRMENTS [47 CFR §§ 15.247(B)(4), 1.1310 & 2.1091].....	18
6.8.1.	<i>Limits</i> .....	18
6.8.2.	<i>MPE Evaluation</i> .....	18
6.9.	TRANSMITTER BAND-EDGE & SPURIOUS CONDUCTED EMISSIONS [47 CFR § 15.247(C)].....	20
6.9.1.	<i>Limits</i> .....	20
6.9.2.	<i>Method of Measurements</i> .....	20

6.9.3.	Test Arrangement .....	20
6.9.4.	Test Equipment List .....	20
6.9.5.	Test Data.....	21
6.10.	TRANSMITTER SPURIOUS RADIATED EMISSIONS AT 3 METERS [47 CFR §§ 15.247(c), 15.209 & 15.205].....	22
6.10.1.	Limits .....	22
6.10.2.	Method of Measurements.....	23
6.10.3.	Test Arrangement .....	23
6.10.4.	Test Equipment List .....	24
6.10.5.	Test Data.....	24
<b>EXHIBIT 7.</b>	<b>MEASUREMENT UNCERTAINTY.....</b>	<b>26</b>
7.1.	LINE CONDUCTED EMISSION MEASUREMENT UNCERTAINTY .....	26
7.2.	RADIATED EMISSION MEASUREMENT UNCERTAINTY .....	27
<b>EXHIBIT 8.</b>	<b>MEASUREMENT METHODS.....</b>	<b>28</b>
8.1.	GENERAL TEST CONDITIONS.....	28
8.1.1.	Normal temperature and humidity.....	28
8.1.2.	Normal power source .....	28
8.1.3.	Operating Condition of Equipment under Test.....	28
8.2.	METHOD OF MEASUREMENTS - AC MAINS CONDUCTED EMISSIONS .....	29
8.3.	EQUIVALENT ISOTROPIC RADIATED POWER (EIRP).....	30
8.4.	SPURIOUS EMISSIONS (CONDUCTED & RADIATED) .....	33
8.4.1.	Band-Edge and Spurious Emissions (Conducted).....	33
8.4.2.	Spurious Emissions (Radiated).....	34
8.5.	ALTERNATIVE TEST PROCEDURES .....	36
8.5.1.	Peak Power Measurements.....	36
8.5.2.	Spurious RF conducted emissions .....	36

## EXHIBIT 1. SUBMITTAL CHECK LIST

Annex No.	Exhibit Type	Description of Contents	Quality Check (OK)
--	Test Report	<ul style="list-style-type: none"> <li>▪ Exhibit 1: Submittal check lists</li> <li>▪ Exhibit 2: Introduction</li> <li>▪ Exhibit 3: Performance Assessment</li> <li>▪ Exhibit 4: EUT Operation and Configuration during Tests</li> <li>▪ Exhibit 5: Summary of test Results</li> <li>▪ Exhibit 6: Measurement Data</li> <li>▪ Exhibit 7: Measurement Uncertainty</li> <li>▪ Exhibit 8: Measurement Methods</li> </ul>	OK
1	Test Data Plots	<ul style="list-style-type: none"> <li>▪ 20 dB Bandwidth (Plots # 1 to 6)</li> <li>▪ Hopping Channel Carrier Frequency Characteristics (Plots # 7 to 15)</li> <li>▪ Band-Edge Spurious Emissions at Antenna Terminals (Plots #16 to 23)</li> <li>▪ Spurious Emissions at Antenna Terminals (Plots # 24 to 32)</li> <li>▪ Radiated Emissions (Plots # 33 to 42)</li> </ul>	OK
2	Test Setup Photos	Radiated Emissions Test Setup Photos	OK
3	External Photos of EUT	Yagi Antenna	OK
4	Internal Photos of EUT	Internal EUT Photos	OK
5	Cover Letters	<ul style="list-style-type: none"> <li>▪ Letter from Ultratech for Certification Request</li> <li>▪ Letter from the Applicant to appoint Ultratech to act as an agent</li> </ul>	OK
6	Attestation Statements	--	--
7	ID Label/Location Info	Refer to Original Filing.	OK
8	Block Diagrams	Refer to Original Filing.	OK
9	Schematic Diagrams	Refer to Original Filing.	OK
10	Parts List/Tune Up Info	Refer to Original Filing.	OK
11	Operational Description	Refer to Original Filing.	OK
12	RF Exposure Info	MPE Evaluation, See Section 6.8 in This Test Report	OK
13	Users Manual	Users Manual Addendum	OK

### ULTRATECH GROUP OF LABS

3000 Bristol Circle, Oakville, Ontario, Canada L6H 6G4  
 Tel. #: 905-829-1570, Fax. #: 905-829-8050, Email: [vic@ultratech-labs.com](mailto:vic@ultratech-labs.com), Website: <http://www.ultratech-labs.com>

File #: MIC-081F15C247

December 5, 2002

*All test results contained in this engineering test report are traceable to National Institute of Standards and Technology (NIST)*

## EXHIBIT 2. INTRODUCTION

### 2.1. SCOPE

<b>Reference:</b>	FCC Part 15, Subpart C, Section 15.247
<b>Title:</b>	Telecommunication – 47 Code of Federal Regulations (CFR), Part 15
<b>Purpose of Test:</b>	To gain FCC Certification Authorization for Frequency Hopping Spread Spectrum Transmitters Operating in the Frequency Band 902.5 - 927.5035 MHz .
<b>Test Procedures:</b>	Both conducted and radiated emissions measurements were conducted in accordance with American National Standards Institute ANSI C63.4 - American National Standard for Methods of Measurement of Radio-Noise Emissions from Low-Voltage Electrical and Electronic Equipment in the Range of 9 kHz to 40 GHz.
<b>Environmental Classification:</b>	[ ] Residential [ x ] Light-industry, Commercial [ x ] Industry

### 2.2. RELATED SUBMITTAL(S)/GRANT(S)

None.

### 2.3. NORMATIVE REFERENCES

Publication	Year	Title
47 CFR Parts 0-19	2001	Code of Federal Regulations – Telecommunication
ANSI C63.4	1992	American National Standard for Methods of Measurement of Radio-Noise Emissions from Low-Voltage Electrical and Electronic Equipment in the Range of 9 kHz to 40 GHz
CISPR 22 & EN 55022	1997 1998	Limits and Methods of Measurements of Radio Disturbance Characteristics of Information Technology Equipment
CISPR 16-1	1999	Specification for Radio Disturbance and Immunity measuring apparatus and methods
FCC Public Notice DA 00-705	2000	Filing and Measurement Guidelines for Frequency Hopping Spread Spectrum Systems
FCC Public Notice DA 00-1407	2000	Part 15 Unlicensed Modular Transmitter Approval

## EXHIBIT 3. PERFORMANCE ASSESSMENT

### 3.1. CLIENT INFORMATION

APPLICANT	
<b>Name:</b>	Microwave Data Systems Inc.
<b>Address:</b>	175 Science Parkway Rochester, NY USA, 14620
<b>Contact Person:</b>	Mr. Dennis McCarthy Agency Compliance Engineer Phone #: 585 242-8440 Fax #: 585 241-5590 Email Address: dmccarthy@microwavedata.com

MANUFACTURER	
<b>Name:</b>	Microwave Data Systems Inc.
<b>Address:</b>	175 Science Parkway Rochester, NY USA, 14620
<b>Contact Person:</b>	Mr. Dennis McCarthy Agency Compliance Engineer Phone #: 585 242-8440 Fax #: 585 241-5590 Email Address: dmccarthy@microwavedata.com

### 3.2. EQUIPMENT UNDER TEST (EUT) INFORMATION

The following information (with the exception of the Date of Receipt) has been supplied by the applicant.

<b>Brand Name:</b>	Microwave Data Systems Inc.
<b>Product Name:</b>	INET
<b>Model Name or Number:</b>	INET900
<b>Serial Number:</b>	Test Sample
<b>Type of Equipment:</b>	Frequency Hopping Spread Spectrum Transmitters
<b>Input Power Supply Type:</b>	External Regulated DC Sources
<b>Primary User Functions of EUT:</b>	Wireless Data Transfer

#### ULTRATECH GROUP OF LABS

3000 Bristol Circle, Oakville, Ontario, Canada L6H 6G4  
Tel. #: 905-829-1570, Fax. #: 905-829-8050, Email: [vic@ultratech-labs.com](mailto:vic@ultratech-labs.com), Website: <http://www.ultratech-labs.com>

File #: MIC-081F15C247  
December 5, 2002

*All test results contained in this engineering test report are traceable to National Institute of Standards and Technology (NIST)*

### 3.3. EUT'S TECHNICAL SPECIFICATIONS

<b>TRANSMITTER</b>	
<b>Equipment Type:</b>	<input type="checkbox"/> Portable <input checked="" type="checkbox"/> Mobile <input checked="" type="checkbox"/> Base Station (fixed use)
<b>Intended Operating Environment:</b>	<input type="checkbox"/> Residential <input checked="" type="checkbox"/> Commercial, light industry & heavy industry
<b>Power Supply Requirement:</b>	13.8 Vdc nominal
<b>RF Output Power Rating:</b>	1 Watt
<b>Operating Frequency Range:</b>	902.5 - 927.5035 MHz
<b>RF Output Impedance:</b>	50 Ohms
<b>Channel Spacing:</b>	317 kHz
<b>Duty Cycle:</b>	Continuous
<b>20 dB Bandwidth:</b>	306 kHz
<b>Modulation Type:</b>	CPFSK
<b>Channel Occupancy:</b>	260 msec within 10 second period
<b>Emission Designation:</b>	Frequency Hopping Spread Spectrum
<b>Oscillator Frequency(ies):</b>	TCXO 16MHz, L.O. – 110.7MHz, 2 <sup>nd</sup> L.O. 100MHz
<b>Antenna Connector Type:</b>	Non-integral, Standard TNC connector (Professional Installation). Please refer to Installation Guide for detailed instruction of antenna installation and RF Exposure Warning.

### 3.4. PERMISSIVE CHANGES MADE IN CERTIFICATED EQUIPMENT

(a) Changes made on the iNET:

1. Relocated the reference clock oscillator in the digital section
2. Re-layed out the power supply circuit and replaced some easily damaged components
3. Re-layed out the power amplifier circuit for increased stability
4. Increased the fine power control of the RF power amplifier by 1.5x
5. Increased the RX baseband filter bandwidth 10% (non RF related)
6. Added a filter circuit to the RSSI to increase accuracy
7. Changed the power detector circuitry from a single chip to a coupler and a chip for enhanced ESD performance
8. Improved the VCO bias circuit to minimize change over temperature
9. Changed the LED ribbon connector to a more compact connector
10. Added a series diode for reverse polarity protection of the main power supply
11. Added an ethernet link detect line

(b) Addition of New Antenna:

Manufacturer: MDS/MAXRAD  
 Type: Yagi  
 P/N: BMOY8903  
 Frequency Range: 890 – 960 MHz  
 In/Out Impedance: 50 Ohms  
 Gain: 8.15 dBi

---

#### ULTRATECH GROUP OF LABS

3000 Bristol Circle, Oakville, Ontario, Canada L6H 6G4  
 Tel. #: 905-829-1570, Fax. #: 905-829-8050, Email: [vic@ultratech-labs.com](mailto:vic@ultratech-labs.com), Website: <http://www.ultratech-labs.com>

File #: MIC-081F15C247

December 5, 2002

*All test results contained in this engineering test report are traceable to National Institute of Standards and Technology (NIST)*

### 3.5. LIST OF EUT'S PORTS

Port Number	EUT's Port Description	Number of Identical Ports	Connector Type	Cable Type (Shielded/Non-shielded)
1	LAN	1	RJ-45 Ethernet	Non-Shielded
2	COM1	1	DB9 Female	Shielded
3	COM2	1	DB9 Male	Shielded
4	Antenna	1	TNC	Shielded
5	Power	1	2 Pin Inline	Non-Shielded

### 3.6. ANCILLARY EQUIPMENT

The EUT was tested while connected to the following representative configuration of ancillary equipment necessary to exercise the ports during tests:

Ancillary Equipment # 1	
Description:	Laptop
Brand:	Toshiba
Model Name or Number:	1605CDS/4.3
Serial Number:	1027387CU
Connected to EUT's Port:	COM1



## EXHIBIT 4. EUT OPERATING CONDITIONS AND CONFIGURATIONS DURING TESTS

### 4.1. CLIMATE TEST CONDITIONS

The climate conditions of the test environment are as follows:

Temperature:	21°C
Humidity:	51%
Pressure:	102 kPa
Power Input Source:	13.8 Vdc nominal

### 4.2. OPERATIONAL TEST CONDITIONS & ARRANGEMENT FOR TESTS

<b>Operating Modes:</b>	<ul style="list-style-type: none"><li>Each of lowest, middle and highest channel frequencies transmits continuously for emissions measurements.</li><li>The EUT operates in normal Frequency Hopping mode for occupancy duration, and frequency separation.</li></ul>
<b>Special Test Software &amp; Hardware:</b>	Special firmware and hardware provided by the Applicant are installed to allow the EUT to operate in hopping mode or at each channel frequency continuously. For example, the transmitter will be operated at each of lowest, middle and highest frequencies individually continuously during testing.
<b>Transmitter Test Antenna:</b>	The EUT is tested with the antenna fitted in a manner typical of normal intended use as non-integral antenna equipment.

<b>Transmitter Test Signals</b>	
<b>Frequency Band(s):</b>	902.5 - 927.5035 MHz
<b>Frequency(ies) Tested:</b>	Lowest: 902.5000 MHz Middle: 915.1600 MHz Highest: 927.5035 MHz
<b>RF Power Output (measured maximum output power):</b>	30 dBm, 1Watt (at antenna terminal)
<b>Normal Test Modulation:</b>	CPFSK
<b>Modulating Signal Source:</b>	Internal

## EXHIBIT 5. SUMMARY OF TEST RESULTS

### 5.1. LOCATION OF TESTS

All of the measurements described in this report were performed at Ultratech Group of Labs located in the city of Oakville, Province of Ontario, Canada.

- AC Powerline Conducted Emissions were performed in UltraTech's shielded room, 24'(L) by 16'(W) by 8'(H).
- Radiated Emissions were performed at the Ultratech's 3 Meter Open Field Test Site (OFTS) situated in the Town of Oakville, province of Ontario.

The above sites have been calibrated in accordance with ANSI C63.4, and found to be in compliance with the requirements of Sec. 2.948 of the FCC Rules. The descriptions and site measurement data of the Oakville Open Field Test Site has been filed with FCC office (FCC File No.: 31040/SIT 1300B3) and Industry Canada office (Industry Canada File No.: IC2049). Last Date of Site Calibration: August 10, 2002.

### 5.2. APPLICABILITY & SUMMARY OF EMC EMISSION TEST RESULTS

FCC Paragraph	Test Requirements	Compliance (Yes/No)
Public Notice DA 00-1407	Part 15 Unlicensed Modular Transmitter Approval	N/A
15.107(a)	AC Power Line Conducted Emissions Measurements (Transmit & Receive)	N/A
15.247(a)(1) & 15.247(a)(1)(i)	Frequency Hopping Systems Characteristics	Yes
15.247(b)(2)	Peak Output Power	Yes
15.247(b)(4), 1.1307, 1.1310, 2.1091 & 2.1093	RF Exposure Limit	Yes
15.247(c)	Band-Edge and RF Conducted Spurious Emissions at the Transmitter Antenna Terminal	Yes
15.247(c), 15.209 & 15.205	Transmitter Radiated Emissions	Yes
The digital circuit portion of the EUT has been tested and verified to comply with FCC Part 15, Subpart B, Class A Digital Devices and the associated Radio Receiver operating in 902.5 - 927.5035 MHz has also been tested and found to comply with FCC Part 15, Subpart B – Radio Receivers. The engineering test report can be provided upon FCC requests.		

### 5.3. MODIFICATIONS INCORPORATED IN THE EUT FOR COMPLIANCE PURPOSES

None.

#### ULTRATECH GROUP OF LABS

3000 Bristol Circle, Oakville, Ontario, Canada L6H 6G4  
 Tel. #: 905-829-1570, Fax. #: 905-829-8050, Email: [vic@ultratech-labs.com](mailto:vic@ultratech-labs.com), Website: <http://www.ultratech-labs.com>

File #: MIC-081F15C247  
 December 5, 2002

*All test results contained in this engineering test report are traceable to National Institute of Standards and Technology (NIST)*

---

---

## EXHIBIT 6. MEASUREMENTS, EXAMINATIONS & TEST DATA FOR EMC EMISSIONS

### 6.1. TEST PROCEDURES

This section contains test results only. Details of test methods and procedures can be found in Exhibit 8 of this report, ANSI C63-4:1992 and FCC Public Notice @ DA 00-705 (March 30, 2000) – Filing and Measurement Guidelines for Frequency Hopping Spread Spectrum Systems.

### 6.2. MEASUREMENT UNCERTAINTIES

The measurement uncertainties stated were calculated in accordance with requirements of UKAS Document NIS 81 with a confidence level of 95%. Please refer to Exhibit 7 for Measurement Uncertainties.

### 6.3. MEASUREMENT EQUIPMENT USED

The measurement equipment used complied with the requirements of the Standards referenced in the Methods & Procedures ANSI C64-3:1992, FCC 15.247 and CISPR 16-1.

### 6.4. ESSENTIAL/PRIMARY FUNCTIONS AS DECLARED BY THE MANUFACTURER

The essential function of the EUT is to correctly communicate data to and from radios over RF link.

---

---

#### ULTRATECH GROUP OF LABS

3000 Bristol Circle, Oakville, Ontario, Canada L6H 6G4  
Tel. #: 905-829-1570, Fax. #: 905-829-8050, Email: [vic@ultratech-labs.com](mailto:vic@ultratech-labs.com), Website: <http://www.ultratech-labs.com>

File #: MIC-081F15C247  
December 5, 2002

*All test results contained in this engineering test report are traceable to National Institute of Standards and Technology (NIST)*

## 6.5. COMPLIANCE WITH FCC PART 15 – GENERAL TECHNICAL REQUIREMENTS

FCC Section	FCC Rules	Manufacturer's Clarification
15.31	The hopping function must be disabled for tests, which should be performed with the EUT transmitting on the number of frequencies specified in this Section. The measurements made at the upper and lower ends of the band of operation should be made with the EUT tuned to the highest and lowest available channels.	Hopping function was disabled during testing
15.203	<p>Described how the EUT complies with the requirement that either its antenna is permanently attached, or that it employs a unique antenna connector, for every antenna proposed for use with the EUT.</p> <p>The exception is in those cases where EUT must be professionally installed. In order to demonstrate that professional installation is required, the following 3 points must be addressed:</p> <ul style="list-style-type: none"> <li>• The application (or intended use) of the EUT</li> <li>• The installation requirements of the EUT</li> <li>• The method by which the EUT will be marketed</li> </ul>	<p>Application descriptions and installation requirements are provided in the product manual. (MDS INET 900 Installation Guide)</p> <p>MDS manufactures products which are sold by MDS's sales department to be used by industrial customers to provide data communication infrastructure, and as such the products are installed by professionals, not by ordinary consumers. Typical installations involve tower construction, antenna installation, feed line fabrication and routing which often is within conduit, radio installation, and power provisioning. Since the length and type of feedline varies widely, professional installation with a standard RF connection is a necessity.</p>
15.204	<p>Provided the information for every antenna proposed for use with the EUT:</p> <p>(a) type (e.g. Yagi, patch, grid, dish, etc...),                      (b) manufacturer and model number                      (c) gain with reference to an isotropic radiator</p>	Please refer to section 3.3 of this test report for details of antenna information
15.247(a)	Description of how the EUT meets the definition of a frequency hopping spread spectrum, found in Section 2.1. Based on the technical description.	The radio hops on 316.5 KHz channels using a pseudo-random sequence. It utilizes greater than 50 frequencies and uses each frequency less than 0.4 seconds within any 10 second period.

FCC Section	FCC Rules	Manufacturer's Clarification
15.247(a)	<p><u>Pseudo Frequency Hopping Sequence:</u>                      Describe how the hopping sequence is generated. Provide an example of the hopping sequence channels, in order to demonstrate that the sequence meets the requirements specified in the definition of a frequency hopping spread spectrum system, found in Section 2.1</p>	<p>The pseudo-random sequence is derived from a Linear Congruential Generator (LCG).  <math display="block">\text{rnd}(i+1) = (\text{rnd}(i)*b + a) \text{ mod } 128</math>                     "a" and "b" are chosen based on system address (Network Name) and are qualified to guarantee a sequence of length 80. Skipped channels are removed from the sequence. Mapping of sequence index to frequency is based on 902.5MHz + index*316.5KHz, where index is a value between 0 and 79.                       A sample sequence is provided listed as ATTACHMENT #1.</p>
15.247(a)	<p><u>Equal Hopping Frequency Use:</u>                      Describe how each individual EUT meets the requirement that each of its hopping channels is used equally on average (e.g. that each new transmission event begins on the next channel in the hopping sequence after final channel used in the previous transmission events).</p>	<p>Average dwell time is controlled by the on-board microprocessor. Hopping is asynchronous to data input. Randomly presented data will be randomly distributed across all channels in the sequence.</p>
15.247(g)	<p>Describe how the EUT complies with the requirement that it be designed to be capable of operating as a true frequency hopping system</p>	<p>The radio will always hop on a minimum of 56 channels. Dwell time is an equal fixed duration on each channel. In the presence of continuous data all channels in the hop sequence will be used equally. This applies to a radio configured as either an Access Point or a remote.</p>
15.247(h)	<p>Describe how the EUT complies with the requirement that it not have the ability to coordinated with other FHSS is an effort to avoid the simultaneous occupancy of individual hopping frequencies by multiple transmitters</p>	<p>Hopping is statically determined based on system address and other configurable parameters. The radio does NOT alter this pattern based on channel occupancy or any other dynamic factors.</p>
Public Notice DA 00-705	<p><u>System Receiver Input Bandwidth:</u>                      Describe how the associated receiver(s) complies with the requirement that its input bandwidth (either RF or IF) matches the bandwidth of the transmitted signal.</p>	<p>The receiver has an IF bandwidth of 400 KHz, matching the bandwidth of the transmitted signal</p>
Public Notice DA 00-705	<p><u>System Receiver Hopping Capability:</u>                      Describe how the associated receiver(s) has the ability to shift frequencies in synchronization with the transmitted signals</p>	<p>Once synchronization is achieved, all radios hop in lock step together with the master. Timing adjustments to cover clock drift are made based on the measured arrival time of dedicated Beacon messages.</p>

## ATTACHMENT #1

Sample Psuedo-Random Sequence (values 0-79)

<b>Index</b>	<b>Channel #</b>	<b>Frequency (Hz)</b>
[00]	28	911367582
[01]	18	908202562
[02]	72	925293667
[03]	62	922128648
[04]	65	923078153
[05]	45	916748115
[06]	32	912633589
[07]	67	923711157
[08]	22	909468570
[09]	25	910418076
[10]	76	926559675
[11]	47	917381118
[12]	66	923394655
[13]	05	904088037
[14]	27	911051080
[15]	36	913899597
[16]	07	904721041
[17]	26	910734578
[18]	70	924660663
[19]	73	925610169
[20]	53	919280130
[21]	40	915165605
[22]	75	926243173
[23]	30	912000585
[24]	33	912950091
[25]	55	919913134
[26]	74	925926671
[27]	13	906620053
[28]	00	902505527
[29]	35	913583095
[30]	44	916431613
[31]	15	907253056
[32]	34	913266593
[33]	78	927192679
[34]	04	903771535
[35]	61	921812146
[36]	48	917697620
[37]	38	914532601
[38]	41	915482107
[39]	63	922445149
[40]	21	909152068
[41]	08	905037543
[42]	43	916115111
[43]	01	902822029
[44]	52	918963628
[45]	23	909785072
[46]	42	915798609

---

### ULTRATECH GROUP OF LABS

3000 Bristol Circle, Oakville, Ontario, Canada L6H 6G4  
Tel. #: 905-829-1570, Fax. #: 905-829-8050, Email: [vic@ultratech-labs.com](mailto:vic@ultratech-labs.com), Website: <http://www.ultratech-labs.com>

File #: MIC-081F15C247

December 5, 2002

*All test results contained in this engineering test report are traceable to National Institute of Standards and Technology (NIST)*

[47]	03	903455033
[48]	12	906303551
[49]	02	903138531
[50]	69	924344161
[51]	56	920229636
[52]	46	917064616
[53]	49	918014122
[54]	71	924977165
[55]	29	911684084
[56]	16	907569558
[57]	51	918647126
[58]	06	904404539
[59]	09	905354045
[60]	60	921495644
[61]	31	912317087
[62]	50	918330624
[63]	11	905987049
[64]	20	908835566
[65]	10	905670547
[66]	77	926876177
[67]	64	922761651
[68]	54	919596632
[69]	57	920546138
[70]	79	927509180
[71]	37	914216099
[72]	24	910101574
[73]	59	921179142
[74]	14	906936554
[75]	17	907886060
[76]	68	924027659
[77]	39	914849103
[78]	58	920862640
[79]	19	908519064

**ULTRATECH GROUP OF LABS**

3000 Bristol Circle, Oakville, Ontario, Canada L6H 6G4

Tel. #: 905-829-1570, Fax. #: 905-829-8050, Email: [vic@ultratech-labs.com](mailto:vic@ultratech-labs.com), Website: <http://www.ultratech-labs.com>

File #: MIC-081F15C247

December 5, 2002

*All test results contained in this engineering test report are traceable to National Institute of Standards and Technology (NIST)*

## 6.6. HOPPING CHANNEL CARRIER FREQUENCY CHARACTERISTICS [47 CFR §§ 15.247(a)(1) & (a)(1)(i)]

### 6.6.1. Limits

- **FCC 47 CFR, Para 15.247(a)(1):** Frequency hopping systems shall have hopping channel carrier frequencies separated by a minimum of 25 kHz or the 20 dB bandwidth of the hopping channel, whichever is greater. The system shall hop to channel frequencies that are selected at the system hopping rate from a pseudorandomly ordered list of hopping frequencies. Each frequency must be used equally on the average by each transmitter. The system receivers shall have input bandwidths that match the hopping channel bandwidths of their corresponding transmitters and shall shift frequencies in synchronization with the transmitted signals.
- **FCC 47 CFR, Para 15.247(a)(1)(i):** For frequency hopping systems operating in the 902–928 MHz band: if the 20 dB bandwidth of the hopping channel is less than 250 kHz, the system shall use at least 50 hopping frequencies and the average time of occupancy on any frequency shall not be greater than 0.4 seconds within a 20 second period; if the 20 dB bandwidth of the hopping channel is 250 kHz or greater, the system shall use at least 25 hopping frequencies and the average time of occupancy on any frequency shall not be greater than 0.4 seconds within a 10 second period. The maximum allowed 20 dB bandwidth of the hopping channel is 500 kHz.

### 6.6.2. Method of Measurements

Refer to FCC 15.247(a)(1) & ANSI C63-4:1992 and Public Notice DA 00-705

#### Carrier Frequency Separation:

The hopping function of the EUT is enabled. Use the spectrum analyzer setting as follows:

- Span = wide enough to capture the peaks of two adjacent channels
- RBW = 1% of the span
- VBW = RBW
- Sweep = Auto
- Detector = peak
- Trace = max hold

#### Number of hopping frequency:

The hopping function of the EUT is enabled. Use the spectrum analyzer setting as follows:

- Span = the frequency band of operation
- RBW = 1% of the span
- VBW = RBW
- Sweep = Auto
- Detector = peak
- Trace = max hold



**Time of Occupancy (Dwell Time):**

The hopping function of the EUT is enabled. Use the spectrum analyzer setting as follows:

- Span = 0 Hz centered on a hopping channel
- RBW = 1 MHz
- VBW = RBW
- Sweep = as necessary to capture the entire dwell time per hopping channel
- Detector = peak
- Trace = max hold

If possible, use the marker-delta function to determine the dwell time. If this value varies with different modes of operation (e.g. data rate modulation format, etc.), repeat this test for each variation. The limit is specified in one of the subparagraphs of this Section. Submit this plot(s). An oscilloscope may be used instead of a spectrum analyzer.

**20 dB Bandwidth:**

Use the spectrum analyzer setting as follows:

- Span = approximately 2 to 3 times the 20 dB bandwidth, centered on a hopping channel
- RBW = 1% of the 20 dB bandwidth
- VBW = RBW
- Sweep = auto
- Detector = peak
- Trace = max hold
- The transmitter shall be transmitting at its maximum data rate.
- Allow the trace to stabilize.
- Use the marker-to-peak function to set the marker to the peak of the emission.
- Use the marker-delta function to measure 20 dB down on both sides of the emission.
- The 20 dB BW is the delta reading in frequency between two markers.

**6.6.3. Test Arrangement**

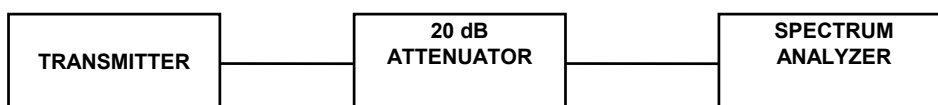

**6.6.4. Test Equipment List**

Test Instruments	Manufacturer	Model No.	Serial No.	Frequency Range
Spectrum Analyzer/ EMI Receiver	Advantest	R3271	15050203	100 Hz – 26.5 GHz
Attenuator	Weinschel Corp	24-20-34	BJ2357	DC – 8.5 GHz

### 6.6.5. Test data

➤ 20 dB Bandwidth Measurements

Channel Frequency (MHz)	20 dB Bandwidth (kHz)	Limit (kHz)	Pass/Fail
Modulation: 2-lever FSK at 512 kbps			
902.50	299	500	Pass
915.16	296	500	Pass
927.50	306	500	Pass
Modulation: 4-lever FSK at 512 kbps			
902.50	287	500	Pass
915.16	289	500	Pass
927.50	286	500	Pass

\* Refer to test data plots # 1 to 6 in Annex 1 for measurement details.

Test Description	FCC Specification	Measured Values	Comments
Channel Hopping Frequency Separation	Minimum of 25 kHz or 20dB BW whichever is greater.	317 kHz	Pass, refer to test data plots # 7 in Annex 1 for measurement data
Number hopping frequencies	At least 25 hopping frequencies	80 channels	Pass, refer to test data plots # 8 to 9 in Annex 1 for measurement data
20 dB BW of the hopping channel	500 kHz maximum	306 kHz	Pass
Average Time of Occupancy	Not greater than 0.4 seconds within 10 second period	260 msec within 10 second period	Pass, refer to test data plots # 10 to 15 in Annex 1 for measurement data

FCC Specification	Manufacturer's Explanation
<b>FCC Requirement @ Section 15.247(a)(1):</b> The system shall hop to channel frequencies that are selected at the system hopping rate from a pseudorandomly ordered list of hopping frequencies. Each frequency must be used equally on the average by each transmitter. The system receivers shall have input bandwidths that match the hopping channel bandwidths of their corresponding transmitters and shall shift frequencies in synchronization with the transmitted signals	Conform. Refer to section 6.5 of this report.
<b>FCC Requirement @ Section 15.247(g):</b> Describe how the EUT complies with the requirement that it be designed to be capable of operating as a true frequency hopping system	Conform. Refer to section 6.5 of this report.
<b>FCC Requirement @ Section 15.247(h):</b> Describe how the EUT complies with the requirement that it does not have the ability to coordinated with other FHSS is an effort to avoid the simultaneous occupancy of individual hopping frequencies by multiple transmitters	Conform. Refer to section 6.5 of this report.

**ULTRATECH GROUP OF LABS**

3000 Bristol Circle, Oakville, Ontario, Canada L6H 6G4  
 Tel. #: 905-829-1570, Fax. #: 905-829-8050, Email: [vic@ultratech-labs.com](mailto:vic@ultratech-labs.com), Website: <http://www.ultratech-labs.com>

File #: MIC-081F15C247

December 5, 2002

*All test results contained in this engineering test report are traceable to National Institute of Standards and Technology (NIST)*

## 6.7. PEAK OUTPUT POWER & EQUIVALENT ISOTROPIC RADIATED POWER (EIRP) [47 CFR § 15.247(b)]

### 6.7.1. Limits

- **47 CFR 15.247(b)(2):** 1 watt for systems employing at least 50 hopping channels; and, 0.25 watts for systems employing less than 50 hopping channels, but at least 25 hopping channels
- **47 CFR 15.247(b)(3):** If the antennas of directional gain greater than 6 dBi are used, the peak power from the intentional radiator shall be reduced below, as appropriate, by the amount in dB that the directional gain of the antenna exceeds 6 dBi.

### 6.7.2. Method of Measurements

Refer to Exhibit 8, Section 8.3 of this test report, 47 CFR 15.247(b)(2)&(3), and ANSI C63-4:1992

### 6.7.3. Test Arrangement

- Conducted Output Power at Antenna Terminals

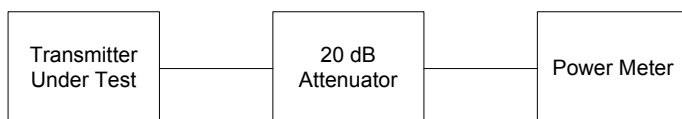

- For EIRP test arrangement, refer to section 8.3 of this test report for details

### 6.7.4. Test Equipment List

Test Instruments	Manufacturer	Model No.	Serial No.	Frequency Range
Power Meter	Hewlett Packard	436A	1725A02249	10 kHz – 50 GHz, sensor dependent
Power Sensor	Hewlett Packard	8481A	2702A68983	10 MHz – 18 GHz
Attenuator	Weinschel Corp	24-20-34	BJ2357	DC – 8.5 GHz
Spectrum Analyzer/ EMI Receiver	Advantest	R3271	15050203	100 Hz – 26.5 GHz
Dipole Antenna	EMCO	3121C	8907-440	30 MHz – 1 GHz
Dipole Antenna	EMCO	3121C	8907-434	30 MHz – 1 GHz
Synthesized Sweeper	Hewlett Packard	83752B	3610A00457	0.01 – 20 GHz

### 6.7.5. Test Data

#### 6.7.5.1. Peak Power Measurements at Antenna Terminals

For systems employing at least 50 hopping channels:

Transmitter Channel	Frequency (MHz)	Peak Power P at Antenna Terminal (dBm)	Limit (dBm)
Lowest	902.5000	27.4	30.0
Middle	915.1600	27.1	30.0
Highest	927.5035	27.1	30.0

In this class II Permissive Change: a MDS ClearWave Yagi Antenna with gain of 6 dBd (8.15 dBi) to be used with this device required the power to be reduced to 27 dBm (nominal) to comply with the 36 dBm EIRP limit. See table below for details.

Antenna Gain (dBd)	Antenna Gain (dBi)	Peak Power P at Antenna Terminal (dBm)	Calculated EIRP (dBm)	EIRP Limit (dBm)
6	8.15	27.4	34.6	36.0

## 6.8. RF EXPOSURE REQUIRMENTS [47 CFR §§ 15.247(b)(4), 1.1310 & 2.1091]

### 6.8.1. Limits

- **FCC 15.247(b)(4):** Systems operating under provisions of this section shall be operated in a manner that ensures that the public is not exposed to radio frequency energy levels in excess of the Commission's guidelines. See @ 1.1307(b)(1).
- **FCC 1.1310:-** The criteria listed in the following table shall be used to evaluate the environmental impact of human exposure to radio-frequency (RF) radiation as specified in 1.1307(b).

TABLE 1—LIMITS FOR MAXIMUM PERMISSIBLE EXPOSURE (MPE)

Frequency range (MHz)	Electric field strength (V/m)	Magnetic field strength (A/m)	Power density (mW/cm <sup>2</sup> )	Averaging time (minutes)
<b>(A) Limits for Occupational/Controlled Exposures</b>				
0.3–3.0 .....	614	1.63	*(100)	6
3.0–30 .....	1842/f	4.89/f	*(900/f <sup>2</sup> )	6
30–300 .....	61.4	0.163	1.0	6
300–1500 .....	.....	.....	f/300	6
1500–100,000 .....	.....	.....	5	6
<b>(B) Limits for General Population/Uncontrolled Exposure</b>				
0.3–1.34 .....	614	1.63	*(100)	30
1.34–30 .....	824/f	2.19/f	*(180/f <sup>2</sup> )	30
30–300 .....	27.5	0.073	0.2	30
300–1500 .....	.....	.....	f/1500	30
1500–100,000 .....	.....	.....	1.0	30

f = frequency in MHz

\* = Plane-wave equivalent power density

NOTE 1 TO TABLE 1: Occupational/controlled limits apply in situations in which persons are exposed as a consequence of their employment provided those persons are fully aware of the potential for exposure and can exercise control over their exposure. Limits for occupational/controlled exposure also apply in situations when an individual is transient through a location where occupational/controlled limits apply provided he or she is made aware of the potential for exposure.

NOTE 2 TO TABLE 1: General population/uncontrolled exposures apply in situations in which the general public may be exposed, or in which persons that are exposed as a consequence of their employment may not be fully aware of the potential for exposure or can not exercise control over their exposure.

### 6.8.2. MPE Evaluation

#### Calculation Method of RF Safety Distance:

$$S = PG/4\pi r^2 = EIRP/4\pi r^2$$

Where: P: power input to the antenna in mW  
 EIRP: Equivalent (effective) isotropic radiated power  
 S: power density mW/cm<sup>2</sup>  
 G: numeric gain of antenna relative to isotropic radiator  
 r: distance to centre of radiation in cm

$$r = \sqrt{EIRP/4\pi S}$$

Evaluation of RF Exposure Compliance Requirements	
RF Exposure Requirements	Compliance with FCC Rules
Minimum calculated separation distance between antenna and persons required: <b>23 cm</b>	Manufacturer' instruction for separation distance between antenna and persons required: <b>23 cm</b> .
Antenna installation and device operating instructions for installers (professional/unskilled users), and the parties responsible for ensuring compliance with the RF exposure requirement	The end product in final installation will be maintained, such that full compliance are always ensured by the manufacturer (Microwave Data Systems Inc.)
Caution statements and/or warning labels that are necessary in order to comply with the exposure limits	Refer to original filing of the user manual for RF Exposure Information.
Any other RF exposure related issues that may affect MPE compliance	None.

**Note:**

The minimum separation distance between the antenna and bodies of users are calculated using the following formula:

$$\text{RF EXPOSURE DISTANCE LIMITS: } r = (PG/4\pi S)^{1/2} = (EIRP/4\pi S)^{1/2}$$

$$S = 902/1500 \text{ mW/cm}^2$$

$$EIRP = 36 \text{ dBm} = 3981 \text{ mW max. (worst case)}$$

$$r = (EIRP/4\pi S)^{1/2} = (3981/4\pi(902/1500))^{1/2} = 23 \text{ cm}$$

Therefore, the minimum separation distance from users is 23 cm when used with the antenna specified in this test report.

## 6.9. TRANSMITTER BAND-EDGE & SPURIOUS CONDUCTED EMISSIONS [47 CFR § 15.247(c)]

### 6.9.1. Limits

In any 100 KHz bandwidth outside the operating frequency band, the radio frequency power that is produced by modulation products of the spreading sequence, the information sequence and the carrier frequency shall be at least 20 dB below that in any 100 KHz bandwidth within the band that contains the highest level of the desired power.

### 6.9.2. Method of Measurements

Refer to Exhibit 8, Section 8.4 of this test report, 47 CFR § 15.247(c) and ANSI C63-4:1992

### 6.9.3. Test Arrangement

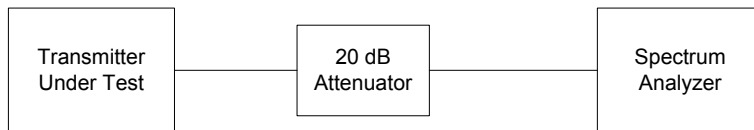

### 6.9.4. Test Equipment List

Test Instruments	Manufacturer	Model No.	Serial No.	Frequency Range
Spectrum Analyzer/ EMI Receiver	Advantest	R3271	15050203	100 Hz – 26.5 GHz
Attenuator	Weinschel Corp	24-20-34	BJ2357	DC – 8.5 GHz

## 6.9.5. Test Data

### 6.9.5.1. *Band-Edge Spurious Emissions During Hopping*

Tests were performed with the following modulations:

- 1) 2-level CPFSK at 512 kbps data rate
- 2) 4-level CPFSK at 512 kbps data rate

Please refer to test data plots # 16 to 23 in Annex 1 for measurement results.

### 6.9.5.2. *RF Conducted Spurious Emissions at Antenna Terminals*

#### 6.9.5.2.1. *Lowest Frequency (902.6 MHz)*

The emissions were scanned from 10 MHz to 10 GHz and no emission was found within 20 dB below the limit. Refer to test data plots # 24 to 26 in Annex 1 for measurement results.

#### 6.9.5.2.2. *Middle Frequency (914.9 MHz)*

The emissions were scanned from 10 MHz to 10 GHz and no emission was found within 20 dB below the limit. Refer to test data plots # 27 to 29 in Annex 1 for measurement results.

#### 6.9.5.2.3. *Highest Frequency (927.2 MHz)*

The emissions were scanned from 10 MHz to 10 GHz and no emission was found within 20 dB below the limit. Refer to test data plots # 30 to 32 in Annex 1 for measurement results.



## 6.10. TRANSMITTER SPURIOUS RADIATED EMISSIONS AT 3 METERS [47 CFR §§ 15.247(c), 15.209 & 15.205]

### 6.10.1. Limits

In any 100 KHz bandwidth outside the operating frequency band, the radio frequency power that is produced by modulation products of the spreading sequence, the information sequence and the carrier frequency shall be either at least 20 dB below that in any 100 KHz bandwidth within the band that contains the highest level of the desired power or shall not exceed the general levels specified in section 15.209(a), which lesser attenuation.

All other emissions inside restricted bands specified in section 15.205(a) shall not exceed the general radiated emission limits specified in section 15.209(a)

#### Remarks:

- Applies to harmonics/spurious emissions that fall in the restricted bands listed in section 15.205. The maximum permitted average field strength is listed in section 15.209.
- 47 CFR § 15.237(c):** The emission limits as specified above are based on measurement instrument employing an average detector. The provisions in section 15.35 for limiting peak emissions apply.

#### FCC CFR 47, Part 15, Subpart C, Para. 15.205(a) - Restricted Frequency Bands

MHz	MHz	MHz	GHz
0.090-0.110	16.42-16.423	399.9-410	4.5-5.15
<sup>1</sup> 0.495-0.505	16.69475-16.69525	608-614	5.35-5.46
2.1735-2.1905	16.80425-16.80475	960-1240	7.25-7.75
4.125-4.128	25.5-25.67	1300-1427	8.025-8.5
4.17725-4.17775	37.5-38.25	1435-1626.5	9.0-9.2
4.20725-4.20775	73-74.6	1645.5-1646.5	9.3-9.5
6.215-6.218	74.8-75.2	1660-1710	10.6-12.7
6.26775-6.26825	108-121.94	1718.8-1722.2	13.25-13.4
6.31175-6.31225	123-138	2200-2300	14.47-14.5
8.291-8.294	149.9-150.05	2310-2390	15.35-16.2
8.362-8.366	156.52475-156.52525	2483.5-2500	17.7-21.4
8.37625-8.38675	156.7-156.9	2655-2900	22.01-23.12
8.41425-8.41475	162.0125-167.17	3260-3267	23.6-24.0
12.29-12.293	167.72-173.2	3332-3339	31.2-31.8
12.51975-12.52025	240-285	3345.8-3358	36.43-36.5
12.57675-12.57725	322-335.4	3600-4400	( <sup>2</sup> )
13.36-13.41.			

<sup>1</sup> Until February 1, 1999, this restricted band shall be 0.490-0.510 MHz.

<sup>2</sup> Above 38.6

#### 47 CFR § 15.209(a)

#### -- Field Strength Limits within Restricted Frequency Bands --

Frequency (MHz)	Field Strength (microvolts/meter)	Measurement Distance (meters)
0.009 - 0.490	2,400 / F (kHz)	300
0.490 - 1.705	24,000 / F (kHz)	30
1.705 - 30.0	30	30
30 - 88	100	3
88 - 216	150	3
216 - 960	200	3
Above 960	500	3

### 6.10.2. Method of Measurements

Refer to Exhibit 8, Section 8.4 of this test report and **ANSI 63.4-1992, Para. 8** for detailed radiated emissions measurement procedures.

The following measurement procedures were also applied:

- Applies to harmonics/spurious that fall in the restricted bands listed in Section 15.205. The maximum permitted average field strength is listed in Section 15.209. A Pre-Amp and highpass filter are used for this measurement.
- For measurement below 1 GHz, set RBW = 100 KHz, VBW  $\geq$  100 KHz, SWEEP=AUTO.
- For measurement above 1 GHz, set RBW = 1 MHz, VBW = 1 MHz (Peak) & VBW = 10 Hz (Average), SWEEP=AUTO.
- If the emission is pulsed, modified the unit for continuous operation, then use the settings above for measurements, then correct the reading by subtracting the peak-average correction factor derived from the appropriate duty cycle calculation. See Section 15.35(b) and (c).

### 6.10.3. Test Arrangement

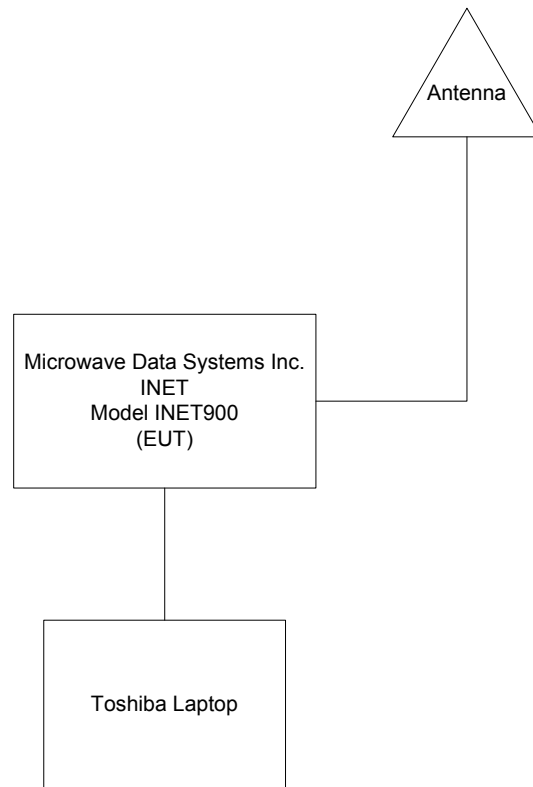

### 6.10.4. Test Equipment List

Test Instruments	Manufacturer	Model No.	Serial No.	Frequency Range
Spectrum Analyzer/ EMI Receiver	Advantest	R3271	15050203	100 Hz – 26.5 GHz
Microwave Amplifier	Hewlett Packard	8449B	3008A00769	1 GHz to 26.5 GHz
Biconilog Antenna	EMCO	3143	1029	20 MHz to 2 GHz
Horn Antenna	EMCO	3155	9701-5061	1 GHz – 18 GHz

### 6.10.5. Test Data

The following test results are the worst-case measurements:

Lowest Frequency (902.5000 MHz)

Frequency (MHz)	RF Peak Level (dBµV/m)	RF Avg Level (dBµV/m)	Antenna Plane (H/V)	Limit 15.209 (dBµV/m)	Limit 15.247 (dBµV/m)	Margin (dB)	Pass/Fail
902.5000	131.50	--	V	--	--	--	--
902.5000	133.41	--	H	--	--	--	--
2707.5000	51.81	46.81	V	54.0	113.4	-7.2	Pass*
2707.5000	51.47	48.47	H	54.0	113.4	-5.5	Pass*
3610.0000	50.09	42.38	V	54.0	113.4	-11.6	Pass*
3610.0000	48.81	42.91	H	54.0	113.4	-11.1	Pass*
4512.5000	54.97	50.75	V	54.0	113.4	-3.3	Pass*
4512.5000	56.25	53.16	H	54.0	113.4	-0.8	Pass*
5415.0000	50.13	41.31	V	54.0	113.4	-12.7	Pass*
5415.0000	49.53	42.97	H	54.0	113.4	-11.0	Pass*
8122.5000	57.25	49.81	V	54.0	113.4	-4.2	Pass*
8122.5000	54.75	47.81	H	54.0	113.4	-6.2	Pass*

The emissions were scanned from 10 MHz to 10 GHz and all emissions within 20 dB below the limits were recorded. Refer to test data plots # 33 & 36 in Annex 1 for band-edge emissions.

\* Frequency in restricted bands, therefore FCC 15.209 limit applied.

Middle Frequency (915.1600 MHz)

Frequency (MHz)	RF Peak Level (dBµV/m)	RF Avg Level (dBµV/m)	Antenna Plane (H/V)	Limit 15.209 (dBµV/m)	Limit 15.247 (dBµV/m)	Margin (dB)	Pass/Fail
915.1600	129.47	--	V	--	--	--	--
915.1600	131.28	--	H	--	--	--	--
2745.4800	50.00	45.53	V	54.0	111.3	-8.5	Pass*
2745.4800	52.59	49.66	H	54.0	111.3	-4.3	Pass*
3660.6400	51.78	45.36	V	54.0	111.3	-8.6	Pass*
3660.6400	49.22	43.81	H	54.0	111.3	-10.2	Pass*
4575.8000	51.84	46.69	V	54.0	111.3	-7.3	Pass*
4575.8000	54.94	51.75	H	54.0	111.3	-2.3	Pass*
7321.2800	57.53	53.34	V	54.0	111.3	-0.7	Pass*
7321.2800	54.00	48.09	H	54.0	111.3	-5.9	Pass*
8236.4400	53.59	43.59	V	54.0	111.3	-10.4	Pass*
8236.4400	52.75	43.66	H	54.0	111.3	-10.3	Pass*

The emissions were scanned from 10 MHz to 10 GHz and all emissions within 20 dB below the limits were recorded. Refer to test data plots # 37 & 38 in Annex 1 for band-edge emissions.

\* Frequency in restricted bands, therefore FCC 15.209 limit applied.

Highest Frequency (927.5035 MHz)

Frequency (MHz)	RF Peak Level (dBµV/m)	RF Avg Level (dBµV/m)	Antenna Plane (H/V)	Limit 15.209 (dBµV/m)	Limit 15.247 (dBµV/m)	Margin (dB)	Pass/Fail
927.5035	130.16	--	V	--	--	--	--
927.5035	129.84	--	H	--	--	--	--
2782.5105	47.91	38.97	V	54.0	110.2	-15.0	Pass*
2782.5105	49.66	45.91	H	54.0	110.2	-8.1	Pass*
3710.0140	52.63	46.97	V	54.0	110.2	-7.0	Pass*
3710.0140	51.03	46.75	H	54.0	110.2	-7.3	Pass*
4637.5175	51.69	46.63	V	54.0	110.2	-7.4	Pass*
4637.5175	51.38	46.53	H	54.0	110.2	-7.5	Pass*
7420.0280	57.53	53.50	V	54.0	110.2	-0.5	Pass*
7420.0280	57.06	51.72	H	54.0	110.2	-2.3	Pass*
8347.5315	54.31	42.63	V	54.0	110.2	-11.4	Pass*
8347.5315	53.44	42.09	H	54.0	110.2	-11.9	Pass*

The emissions were scanned from 10 MHz to 10 GHz and all emissions within 20 dB below the limits were recorded. Refer to test data plots # 39 - 42 in Annex 1 for band-edge emissions.

\* Frequency in restricted bands, therefore FCC 15.209 limit applied.

## EXHIBIT 7. MEASUREMENT UNCERTAINTY

The measurement uncertainties stated were calculated in accordance with the requirements of NIST Technical Note 1297 and NIS 81 (1994)

### 7.1. LINE CONDUCTED EMISSION MEASUREMENT UNCERTAINTY

CONTRIBUTION (Line Conducted)	PROBABILITY DISTRIBUTION	UNCERTAINTY (dB)	
		9-150 kHz	0.15-30 MHz
EMI Receiver specification	Rectangular	$\pm 1.5$	$\pm 1.5$
LISN coupling specification	Rectangular	$\pm 1.5$	$\pm 1.5$
Cable and Input Transient Limiter calibration	Normal (k=2)	$\pm 0.3$	$\pm 0.5$
Mismatch: Receiver VRC $\Gamma_1 = 0.03$ LISN VRC $\Gamma_R = 0.8(9 \text{ kHz}) 0.2 (30 \text{ MHz})$ Uncertainty limits $20\text{Log}(1+\Gamma_1\Gamma_R)$	U-Shaped	$\pm 0.2$	$\pm 0.3$
System repeatability	Std. deviation	$\pm 0.2$	$\pm 0.05$
Repeatability of EUT	--	--	--
Combined standard uncertainty	Normal	$\pm 1.25$	$\pm 1.30$
Expanded uncertainty U	Normal (k=2)	$\pm 2.50$	$\pm 2.60$

Sample Calculation for Measurement Accuracy in 450 kHz to 30 MHz Band:

$$u_c(y) = \sqrt{\sum_{i=1}^m u_i^2(y)} = \pm \sqrt{(1.5^2 + 1.5^2)/3 + (0.5/2)^2 + (0.05/2)^2 + 0.35^2} = \pm 1.30 \text{ dB}$$

$$U = 2u_c(y) = \pm 2.6 \text{ dB}$$

## 7.2. RADIATED EMISSION MEASUREMENT UNCERTAINTY

CONTRIBUTION (Radiated Emissions)	PROBABILITY DISTRIBUTION	UNCERTAINTY (+ dB)	
		3 m	10 m
Antenna Factor Calibration	Normal (k=2)	$\pm 1.0$	$\pm 1.0$
Cable Loss Calibration	Normal (k=2)	$\pm 0.3$	$\pm 0.5$
EMI Receiver specification	Rectangular	$\pm 1.5$	$\pm 1.5$
Antenna Directivity	Rectangular	+0.5	+0.5
Antenna factor variation with height	Rectangular	$\pm 2.0$	$\pm 0.5$
Antenna phase center variation	Rectangular	0.0	$\pm 0.2$
Antenna factor frequency interpolation	Rectangular	$\pm 0.25$	$\pm 0.25$
Measurement distance variation	Rectangular	$\pm 0.6$	$\pm 0.4$
Site imperfections	Rectangular	$\pm 2.0$	$\pm 2.0$
Mismatch: Receiver VRC $\Gamma_1 = 0.2$ Antenna VRC $\Gamma_R = 0.67(\text{Bi}) 0.3 (\text{Lp})$ Uncertainty limits $20\text{Log}(1 \pm \Gamma_1 \Gamma_R)$	U-Shaped	+1.1 -1.25	$\pm 0.5$
System repeatability	Std. Deviation	$\pm 0.5$	$\pm 0.5$
Repeatability of EUT		-	-
Combined standard uncertainty	Normal	+2.19 / -2.21	+1.74 / -1.72
Expanded uncertainty U	Normal (k=2)	+4.38 / -4.42	+3.48 / -3.44

Calculation for maximum uncertainty when 3m biconical antenna including a factor of k = 2 is used:

$$U = 2u_c(y) = 2x(+2.19) = +4.38 \text{ dB} \quad \text{And} \quad U = 2u_c(y) = 2x(-2.21) = -4.42 \text{ dB}$$

## EXHIBIT 8. MEASUREMENT METHODS

### 8.1. GENERAL TEST CONDITIONS

The following test conditions shall be applied throughout the tests covered in this report.

#### 8.1.1. Normal temperature and humidity

- Normal temperature: +15°C to +35°C
- Relative Humidity: +20% to 75%

The actual values during tests shall be recorded in the test report.

#### 8.1.2. Normal power source

##### 8.1.2.1. Mains Voltage

The nominal test voltage of the equipment to be connected to mains shall be the nominal mains voltage which is the declared voltage or any of the declared voltages for which the equipment was designed.

The frequency of test power source corresponding to the AC mains shall be between 59 Hz and 61 Hz.

##### 8.1.2.2. Battery Power Source.

For operation from battery power sources, the nominal test voltage shall be as declared by the equipment manufacturer. This shall be recorded in the test report.

#### 8.1.3. Operating Condition of Equipment under Test

- All tests were carried out while the equipment operated at the following frequencies:
  - The lowest operating frequency,
  - The middle operating frequency and
  - The highest operating frequency
- Modulation were applied using the Test Data sequence
- The transmitter was operated at the highest output power, or in the case the equipment able to operate at more than one power level, at the lowest and highest output powers

## 8.2. METHOD OF MEASUREMENTS - AC MAINS CONDUCTED EMISSIONS

- AC Mains conducted emissions measurements were performed in accordance with the standard against appropriate limits for each detector function.
- The test was performed in the shielded room, 16'(L) by 16'(W) by 12'(H).
- The test was performed over the frequency range from 450 kHz to 30 MHz to determine the line-to-ground radio noise voltage which was conducted from the EUT power-input terminals that were directly connected to a public power network.
- The EUT normally received power from another device that connects to the public utility ac power lines, measurements would be made on that device with the EUT in operation to ensure that the device continues to comply with the appropriate limits while providing the EUT with power.
- If the EUT operates only from internal or dedicated batteries, with no provisions for connection to the public utility ac power lines, AC Mains conducted measurements are not required.
- Table-top devices were placed on a platform of nominal size 1 m by 1.5m raised 80 cm above the conducting ground plane.
- The EUT current-carrying power lead, except the ground (safety) lead, was individually connected through a LISN to the power source. All unused 50-Ohm connectors of the LISN was terminated in 50-ohm when not connected to the measuring instruments.
- The line cord of the EUT connected to one LISN which was connected to the measuring instrument. Those power cords for the units of devices not under measurement were connected to a separate multiple ac outlet. Drawings and photographs of typically conducted emission test setups were shown in the Test Report. Each current-carrying conductor of the EUT shall be individually tested.
- The EUT was normally operated with a ground (safety) connection, the EUT was connected to the ground at the LISN through a conductor provided in the lead from the ac power mains to the LISN.
- The excess length of the power cord was folded back and forth in an 8-shape on a wooden strip with a vertical prong located on the top of the LISN case.
- The EUT was set-up in its typical configuration and operated in its various modes as described in 3.2 of the test report.
- A preliminary scan was made by using spectrum analyzer system with the detector function set to PEAK mode (9 KHz RBW, VBW > RBW), frequency span 450 kHz to 30 MHz.
- The maximum conducted emission for a given mode of operation was found by using the following step-by-step procedure:
  - Step1. Monitor the frequency range of interest at a fixed EUT azimuth.
  - Step2. Manipulate the system cables and peripheral devices to produce highest amplitude signal relative to the limit. Note the amplitude and frequency of the suspect signal.
  - Step3. The effects of various modes of operation is examined. This is done by varying equipment operation modes as step 2 is being performed.
  - Step4. After completing step 1 through 3, record EUT and peripheral device configuration, mode of operation, cable configuration, signal levels and frequencies for final test.
- Each highest signal level at the maximized test configuration was zoomed in a small frequency span on the spectrum analyzer's display (the manipulation of cables and peripheral devices and EUT operation modes might have to be repeated to obtain the highest signal level with the spectrum analyzer set to PEAK detector mode 10 KHz RBW and VBW > RBW). The spectrum analyzer was then set to CISPR QUASI-PEAK detector mode (9 KHz RBW, 1 MHz VBW) and AVERAGE detector mode (10 kHz RBW, 1 Hz VBW). The final highest RF signal levels and frequencies were record.



- **Broad-band ac Powerline conducted emissions**:- If the EUT exhibits ac Powerline conducted emissions that exceed the limit with the instrument set to the quasi-peak mode, then measurements should be made in the average mode. If the amplitude measured in the quasi-peak mode is at least 6 dB higher than the amplitude measured in the average mode, the level measured in quasi peak mode may be reduced by 13 dB before comparing it to the limit.

### 8.3. EQUIVALENT ISOTROPIC RADIATED POWER (EIRP)

- The following shall be applied to the combination(s) of the radio device and its intended antenna(e).
- If the RF level is user adjustable, all measurements shall be made with the highest power level available to the user for that combination.
- The following method of measurement shall apply to both conducted and radiated measurements.
- The radiated measurements are performed at the Ultratech Calibrated Open Field Test Site.
- The measurement shall be performed using normal operation of the equipment with modulation.

Test procedure shall be as follows:

#### Step 1: Duty Cycle measurements

- Using a spectrum analyzer with the frequency span set to 0 Hz and the sweep time set at a suitable value to capture the envelope peaks and the duty cycle of the transmitter output signal;
- The duty cycle of the transmitter,  $x = \text{Tx on} / (\text{Tx on} + \text{Tx off})$  with  $0 < x < 1$ , is measure and recorded in the test report. For the purpose of testing, the equipment shall be operated with a duty cycle that is equal or more than 0.1.

#### Step 2: Calculation of Peak and Average EIRP

- The peak output power of the transmitter shall be determined using a wideband, calibrated RF Peak Power Meter with the power sensor with an integration period that exceeds the repetition period of the transmitter by a factor 5 or more. The observed value shall be recorded as “P” (in dBm);
- The Average EIRP shall be calculated from the above measured power output “A”, the observed duty cycle x, and the applicable antenna assembly gain “G” in dBi, according to the formula:

$$\text{Peak EIRP} = P + G$$

$$\text{Average EIRP} = \text{Peak EIRP} + 10\log(1/x)$$

Figure 1

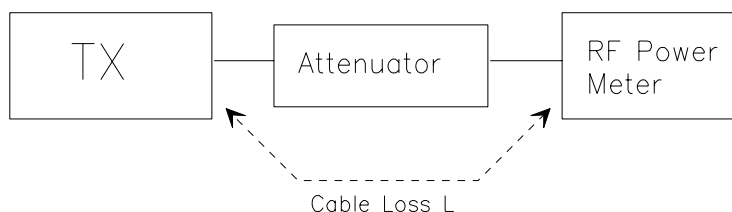

**Step 3:** Substitution Method. See Figure 2

- (a) The measurements was performed in the absence of modulation (un-modulated)
- (b) Test was performed at listed 3m open area test site (listed with FCC, IC, ITI, NVLAP, ACA & VCCI).
- (c) The transmitter under test was placed at the specified height on a non-conducting turntable (80 cm height)
- (d) The dipole test antenna was used and tuned to the transmitter carrier frequency.
- (e) The spectrum analyzer was tuned to transmitter carrier frequency. The test antenna was lowered or raised from 1 to 4 meters until the maximum signal level was detected.
- (f) The transmitter was rotated through 360° about a vertical axis until a higher maximum signal was received.
- (g) The test antenna was lowered or raised again from 1 to 4 meters until a maximum was obtained. This level was recorded.
- (h) The substitution dipole antenna and the signal generator replaced the transmitter and antenna under test in the same position, and the substitution dipole antenna was placed in vertical polarization. The test dipole antenna was lowered or raised as necessary to ensure that the maximum signal is stilled received.
- (i) The input signal to the substitution antenna was adjusted in level until an equal or a known related level to that detected from the transmitter was obtained in the test receiver. The maximum carrier radiated power is equal to the power supply by the generator.
- (j) The substitution antenna gain and cable loss were added to the signal generator level for the corrected ERP level.
- (k) Repeat steps (c) to (j) with the substitution antenna oriented in horizontal polarization.
- (l) Actual gain of the EUT's antenna is the difference of the measured ERP and measured RF power at the RF port. Correct the antenna gain if necessary.

**Figure 2**

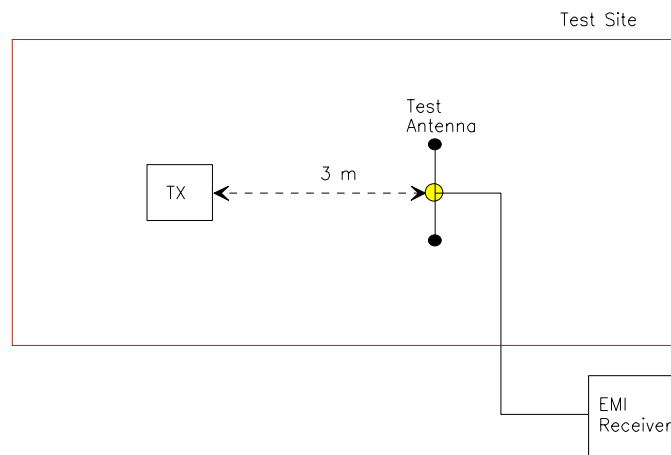
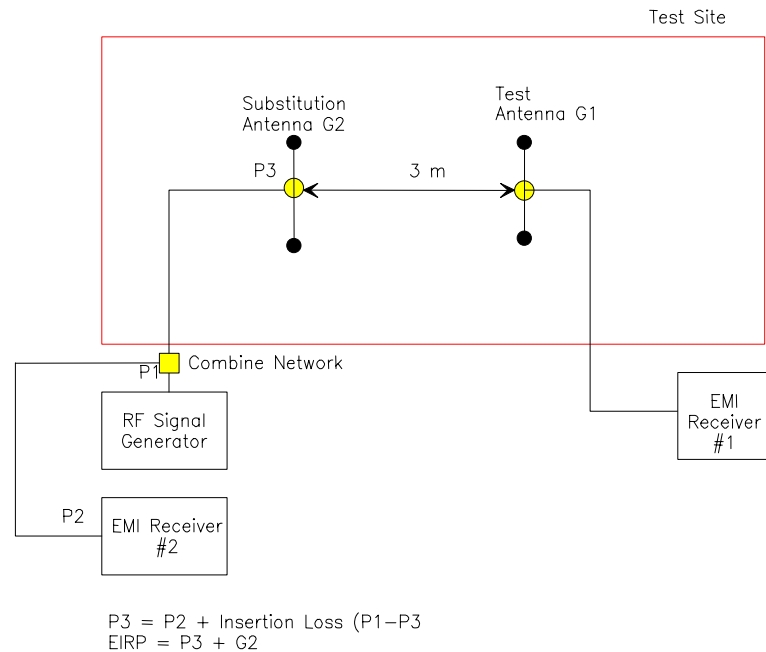

Figure 3



Use the following spectrum analyzer settings:

- Span = approximately 5 times the 20 dB BW, centered on a hopping channel
- RBW > 20 dB BW of the emission measured
- VBW = RBW
- Trace = max hold
- Allow the trace to stabilize
- Use the marker-to-marker function to set the marker to the peak of the emission.
- The indicated level is the peak output power (with the addition of the external attenuation and cable loss).
- The limit is specified in one of the subparagraphs of this Section.
- Submit this plot.
- A peak responding power meter may be used instead of a spectrum analyzer.

## 8.4. SPURIOUS EMISSIONS (CONDUCTED & RADIATED)

For both conducted and radiated measurements, the spurious emissions were scanned from the lowest frequency generated by the EUT or 10 MHz whichever is lower to 10<sup>th</sup> harmonic of the highest frequency generated by the EUT.

### 8.4.1. Band-Edge and Spurious Emissions (Conducted)

#### Band-Edge Compliance of RF Conducted Emissions:

Use the following spectrum analyzer settings:

- The radio was connected to the measuring equipment via a suitable attenuator.
- Span = wide enough to capture the peak level of the emission operating on the channel closest to the band-edge, as well as any modulation products which fall outside of the authorized band of operation.
- RBW = 1 % of the span
- VBW = RBW
- Sweep = auto
- Detector function = peak
- Trace = max hold
- Allow the trace to stabilize
- Set the marker on the emission at the band-edge, or on the highest modulation product outside of the band, if this level is greater than that at the band-edge
- Enable the marker-delta function, then use the marker-to-peak function to move the marker to the peak of the in-band emission.
- The marker-delta value now displayed must comply with the limit specified
- Now, using the same instrument settings, enable the hopping function of the EUT
- Allow the trace to stabilize
- Follow the same procedure listed above to determine if any spurious emissions cause by the hopping function also comply with the specify limits.
- Submit this plot

#### Spurious RF Conducted Emissions:

Use the following spectrum analyzer settings:

- The radio was connected to the measuring equipment via a suitable attenuator.
- Span = wide enough to capture the peak level of the in-band-emission and all spurious emissions (e.g. harmonics) from the lowest frequency generated in the EUT up through the 10<sup>th</sup> harmonic. Typically, several plots are required to cover this entire span.
- RBW = 100 kHz
- VBW = RBW
- Sweep = auto
- Detector function = peak
- Trace = max hold
- Allow the trace to stabilize
- Set the marker on the any spurious emission recorded. The level displayed must comply with the limit specified in this Section.
- Submit this plot

### 8.4.2. Spurious Emissions (Radiated)

- The radiated emission measurements were performed at the UltraTech's 3 Meter Open Field Test Site (OFTS) situated in the Town of Oakville, province of Ontario. The Attenuation Characteristics of OFTS have been filed to FCC, Industry Canada, ACA/Austel, NVLap and ITI.
- Radiated emissions measurements were made using the following test instruments:
  1. Calibrated EMCO BiconiLog antenna in the frequency range from 30 MHz to 2000 MHz.
  2. Calibrated Emco Horn antennas in the frequency range above 1000 MHz (1GHz - 40 GHz).
  3. The test is required for any spurious emission or modulation product that falls in a Restricted Band, as defined in Section 15.205. It must be performed with the highest gain of each type of antenna proposed for use with the EUT. Use the following spectrum analyzer settings:
    - RBW = 100 kHz for  $f < 1\text{GHz}$  and RBW = 1 MHz for  $f \geq 1\text{ GHz}$
    - VBW = RBW
    - Sweep = auto
    - Detector function = peak
    - Trace = max hold
    - Follows the guidelines in ANSI C63.4-1992 with respect to maximizing the emission by rotating the EUT, measuring the emission while the EUT is situated in three orthogonal planes (if appropriate), adjusting the measurement antenna height and polarization, etc.. A pre-amp and highpass filter are required for this test, in order to provide the measuring system with sufficient sensitivity.
    - Allow the trace to stabilize.
    - The peak reading of the emission, after being corrected by the antenna correction factor, cable loss, pre-amp gain, etc.... is the peak field strength which comply with the limit specified in Section 15.35(b)

#### Calculation of Field Strength:

The field strength is calculated by adding the calibrated antenna factor and cable factor, and subtracting the Amplifier gain (if any) from the measured reading. The basic equation with a sample calculation is as follows:

$$FS = RA + AF + CF - AG$$

Where FS = Field Strength  
RA = Receiver/Analyzer Reading  
AF = Antenna Factor  
CF = Cable Attenuation Factor  
AG = Amplifier Gain

Example: If a receiver reading of 60.0 dBuV is obtained, the antenna factor of 7.0 dB/m and cable factor of 1.0 dB are added, and the amplifier gain of 30 dB is subtracted. The actual field strength will be:

$$\begin{aligned} \text{Field Level} &= 60 + 7.0 + 1.0 - 30 = 38.0 \text{ dBuV/m.} \\ \text{Field Level} &= 10^{(38/20)} = 79.43 \text{ uV/m.} \end{aligned}$$

- Submit this test data
- Now set the VBW to 10Hz, while maintaining all of the other instrument settings. This peak level, once corrected, must comply with the limit specified in Section 15.209. If the dwell time per channel of the hopping signal is less than 100ms, then the reading obtained may be further adjusted by a “duty cycle correction factor”, derived from  $10\log(\text{dwell time}/100\text{ms})$  in an effort to demonstrate compliance with the 15.209.
- Submit test data

### **Maximizing The Radiated Emissions:**

- The frequencies of emissions was first detected. Then the amplitude of the emissions was measured at the specified measurement distance using required antenna height, polarization, and detector characteristics.
- During this process, cables and peripheral devices were manipulated within the range of likely configuration.
- For each mode of operation required to be tested, the frequency spectrum was monitored. Variations in antenna heights (from 1 meter to 4 meters above the ground plane), antenna polarization (horizontal plane and vertical plane), cable placement and peripheral placement were explored to produce the highest amplitude signal relative to the limit.

The maximum radiated emission for a given mode of operation was found by using the following step-by-step procedure:

Step1: Monitor the frequency range of interest at a fixed antenna height and EUT azimuth.

Step2: Manipulate the system cables to produce highest amplitude signal relative to the limit. Note the amplitude and frequency of the suspect signal.

Step3: Rotate the EUT 360 degrees to maximize the suspected highest amplitude signal. If the signal or another at a different frequency is observed to exceed the previously noted highest amplitude signal by 1 dB or more, go back to the azimuth and repeat Step 2. Otherwise, orient the EUT azimuth to repeat the highest amplitude observation and proceed.

Step4: Move the antenna over its full allowable range of travel (1 to 4 meters) to maximize the suspected highest amplitude signal. If the signal or another at a different frequency is observed to exceed the previously noted highest amplitude signal by 1 dB or more, return to Step 2 with the highest amplitude observation and proceed.

Step5: Change the polarization of the antenna and repeat Step 2 through 4. Compare the resulting suspected highest amplitude signal with that found for the other polarization. Select and note the higher of the two signals. This signal is termed the highest observed signal with respect to the limit for this EUT operational mode.

Step6: The effects of various modes of operation is examined. This is done by varying the equipment modes as steps 2 through 5 are being performed.

Step7: After completing steps 1 through 6, record the final highest emission level, frequency, antenna polarization and detector mode of the measuring instrument.

## 8.5. ALTERNATIVE TEST PROCEDURES

If the antenna conducted tests cannot be performed on this device, radiated tests show compliance with the peak output power limit specified in Section 15.247(b) and the spurious RF conducted emission limit specified in Section 15.247(c) are acceptable. As stated previously, a pre-amp, and, in the later case, a high pass filter, are required for the following measurements:

### 8.5.1. Peak Power Measurements

Calculate the transmitter's peak power using the following equation:

$$E = 30PG/d$$
$$P = (Ed)^2/30G$$

Where:

- E: measured maximum fundamental field strength in V/m. Utilizing a RBW, the 20 dB bandwidth of the emission  $VBW > RBW$ , peak detector function. Follow the procedures in C63.4-1992 with respect to maximizing the emission
- G is numeric gain of the transmitting antenna with reference to an isotropic radiator
- D is the distance in meters from which the field strength was measured
- P is the distance in meters from which the field strength was measured

### 8.5.2. Spurious RF conducted emissions

The demonstrate compliance with the spurious RF conducted emission requirement of Section 15.2479(c), use the following spectrum analyzer settings:

- Span = wide enough to fully capture the emission being measured
- RBW = 100 kHz
- Sweep = auto
- Detector function = peak
- Trace = max hold
- Measure the field strength of both the fundamental and all spurious emissions with these settings.
- Follow the procedures C62-4:1994 with respect to maximizing the emissions. The measured field strength of all spurious emissions must be below the measured field strength of the fundamental emission by the amount specified in Section 15.247©. Note that if the emission falls in a Restricted Band, as defined in Section 15.205, the procedure for measuring spurious radiated emissions listed above must be followed