

Radio Test Report

**FCC Part 90 and RSS-119
(406.1 MHz to 430 MHz and 450 MHz to 470 MHz)**

Model: LN400

COMPANY: GE MDS LLC
175 Science Parkway
Rochester, NY 14620

TEST SITE(S): National Technical Systems - Silicon Valley
41039 Boyce Road.
Fremont, CA. 94538-2435

REPORT DATE: May 22, 2015

REISSUE DATE: June 26, 2015

FINAL TEST DATES: March 9, April 27, 28, 29, 30 and May 1, 2015

TOTAL NUMBER OF PAGES: 76

PROGRAM MGR /
TECHNICAL REVIEWER:

QUALITY ASSURANCE DELEGATE /
FINAL REPORT PREPARER:

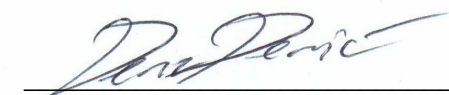

Deniz Demirci
Senior Wireless /EMC Engineer



David Guidotti
Senior Technical Writer



National Technical Systems - Silicon Valley is accredited by the A2LA, certificate number 0214.26, to perform the test(s) listed in this report, except where noted otherwise. This report and the information contained herein represent the results of testing test articles identified and selected by the client performed to specifications and/or procedures selected by the client. National Technical Systems (NTS) makes no representations, expressed or implied, that such testing is adequate (or inadequate) to demonstrate efficiency, performance, reliability, or any other characteristic of the articles being tested, or similar products. This report should not be relied upon as an endorsement or certification by NTS of the equipment tested, nor does it represent any statement whatsoever as to its merchantability or fitness of the test article, or similar products, for a particular purpose. This report shall not be reproduced except in full

REVISION HISTORY

Rev#	Date	Comments	Modified By
-	May 22, 2015	First release	
1	June 17, 2015	Reissued to correct the year reference for C63.4	David Guidotti
2	June 26, 2015	Reissued to update the year reference for C63.4	David Guidotti

TABLE OF CONTENTS

REVISION HISTORY	2
TABLE OF CONTENTS	3
SCOPE.....	4
OBJECTIVE	5
STATEMENT OF COMPLIANCE.....	5
DEVIATIONS FROM THE STANDARDS.....	5
TEST RESULTS.....	6
FCC PART 90 AND RSS-119.....	6
EXTREME CONDITIONS	7
MEASUREMENT UNCERTAINTIES.....	7
EQUIPMENT UNDER TEST (EUT) DETAILS.....	8
GENERAL.....	8
OTHER EUT DETAILS.....	8
ENCLOSURE.....	8
MODIFICATIONS.....	8
SUPPORT EQUIPMENT.....	8
EUT INTERFACE PORTS	9
EUT OPERATION	9
TESTING	10
GENERAL INFORMATION.....	10
RF PORT MEASUREMENT PROCEDURES	11
OUTPUT POWER.....	11
BANDWIDTH MEASUREMENTS	12
CONDUCTED SPURIOUS EMISSIONS.....	12
TRANSMITTER MASK MEASUREMENTS.....	13
FREQUENCY STABILITY.....	13
TRANSIENT FREQUENCY BEHAVIOR:.....	13
RADIATED EMISSIONS MEASUREMENTS.....	14
INSTRUMENTATION	15
FILTERS/ATTENUATORS	15
ANTENNAS.....	15
ANTENNA MAST AND EQUIPMENT TURNTABLE.....	15
SAMPLE CALCULATIONS	16
SAMPLE CALCULATIONS - CONDUCTED SPURIOUS EMISSIONS	16
SAMPLE CALCULATIONS –RADIATED FIELD STRENGTH.....	16
SAMPLE CALCULATIONS –RADIATED POWER.....	17
RECEIVER RADIATED SPURIOUS EMISSIONS SPECIFICATION LIMITS	18
APPENDIX A TEST EQUIPMENT CALIBRATION DATA	19
APPENDIX B TEST DATA	21
END OF REPORT	76

SCOPE

Tests have been performed on the GE MDS LLC model LN400, pursuant to the relevant requirements of the following standard(s) in order to obtain device certification against the regulatory requirements of the Federal Communications Commission and Industry Canada.

- Code of Federal Regulations (CFR) Title 47 Part 2
- RSS-Gen Issue 4, November 2014
- CFR 47 Part 90 (Private Land Mobile Radio Service) Subpart I
- RSS-119, Issue 11, June 2011 (Land Mobile and Fixed Radio Transmitters and Receivers Operating the Frequency Range 27.41 to 960 MHz)

Conducted and radiated emissions data has been collected, reduced, and analyzed within this report in accordance with measurement guidelines set forth in the following reference standards and as outlined in National Technical Systems - Silicon Valley test procedures:

ANSI C63.4:2014

ANSI TIA-603-C August 17, 2004

The intentional radiator above has been tested in a simulated typical installation to demonstrate compliance with the relevant Industry Canada performance and procedural standards.

Every practical effort was made to perform an impartial test using appropriate test equipment of known calibration. All pertinent factors have been applied to reach the determination of compliance.

The test results recorded herein are based on a single type test of the GE MDS LLC model LN400 and therefore apply only to the tested sample. The sample was selected and prepared by Dennis McCarthy of GE MDS LLC.

OBJECTIVE

The primary objective of the manufacturer is compliance with the regulations outlined in the previous section.

Prior to marketing in the USA, the device requires certification. Prior to marketing in Canada, Class I transmitters, receivers and transceivers require certification.

Certification is a procedure where the manufacturer submits test data and technical information to a certification body and receives a certificate or grant of equipment authorization upon successful completion of the certification body's review of the submitted documents. Once the equipment authorization has been obtained, the label indicating compliance must be attached to all identical units, which are subsequently manufactured.

Maintenance of compliance is the responsibility of the manufacturer. Any modification of the product which may result in increased emissions should be checked to ensure compliance has been maintained (i.e., printed circuit board layout changes, different line filter, different power supply, harnessing or I/O cable changes, etc.).

STATEMENT OF COMPLIANCE

The tested sample of GE MDS LLC model LN400 complied with the requirements of the standards and frequency bands declared in the scope of this test report.

Maintenance of compliance is the responsibility of the manufacturer. Any modifications to the product should be assessed to determine their potential impact on the compliance status of the device with respect to the standards detailed in this test report.

DEVIATIONS FROM THE STANDARDS

No deviations were made from the published requirements listed in the scope of this report.

TEST RESULTS
FCC Part 90 and RSS-119

FCC	Canada	Description	Measured	Limit	Result
Transmitter Modulation, output power and other characteristics					
§2.1033 (c) (5) § 90.35	RSS-119	Frequency range(s)	406.1 - 430 MHz 450 - 470 MHz	406.1 - 430 MHz 450 - 470 MHz	Pass
§2.1033 (c) (6) §2.1033 (c) (7) § 2.1046 § 90.205	RSS-119	RF power output at the antenna terminals	19.6 - 41.2 dBm conducted	Determined based on License	Pass
§2.1033 (c) (4) § 2.1047 § 90.210	RSS-119	Emission types	D1D		
		Emission mask C, D, E	Within mask	Shall be within mask	Pass
-	RSS-119	Emission mask Y	Within mask	Shall be within mask	Pass
§ 90.221	-	Adjacent Channel Power	Below limits	§ 90.221 (b)(1) Table	Pass
§ 2.1049 § 90.209	RSS-GEN 6.6 RSS-119	Occupied Bandwidth	5.16 kHz 10.3 kHz 10.8 kHz 17.2 kHz 21.4 kHz	6.0 kHz 11.25 kHz 20.0 kHz 22.0 kHz	Pass
§ 90.214	RSS-119	Transient Frequency Behavior	Complies, within limits		
Transmitter spurious emissions					
§ 2.1051 § 2.1057	RSS-119	At the antenna terminals	-25.7 dBm @ 305.37 MHz (-0.7 dB)	-25 dBm (Mask E)	Pass
§ 2.1053 § 2.1057	RSS-119	Field strength	--31.6 dBm erp @ 1290.0 MHz (-6.6 dB)	-25.0 dBm erp	Pass
Receiver spurious emissions					
15.109	RSS-GEN 7.1.3	At the antenna terminals	0.1 nW (-70.1 dBm)	< 1 GHz: 2 nW > 1 GHz: 5 nW	Pass
15.109	RSS-GEN 7.1.2 Table 2	Field strength	23.0 dBµV/m @ 54.96 MHz (-17.0 dB)	See limit table on page 18	Pass
Other details					
§ 2.1055 § 90.213	RSS-119	Frequency stability	0.1 ppm	0.5 ppm	Pass
§ 2.1093	RSS-102	RF Exposure	Complies, see separate exhibit.		
§2.1033 (c) (8)	-	Final radio frequency amplifying circuit's dc voltages and currents for normal operation over the power range	34.5 VDC, 755 mA (Full power)		
Notes: None					

EXTREME CONDITIONS

Frequency stability is determined over extremes of temperature and voltage. The extremes of voltage were 10 to 60 VDC.

The extremes of temperature were -30°C to +50°C as specified in FCC §2.1055(a)(1).

MEASUREMENT UNCERTAINTIES

ISO/IEC 17025 requires that an estimate of the measurement uncertainties associated with the emissions test results be included in the report. The measurement uncertainties given below are based on a 95% confidence level (based on a coverage factor (k=2) and were calculated in accordance with NAMAS document NIS 81 and M3003.

Measurement Type	Measurement Unit	Frequency Range	Expanded Uncertainty
RF frequency	Hz	25 to 7,000 MHz	1.7×10^{-7}
RF power, conducted	dBm	25 to 7,000 MHz	± 0.52 dB
Conducted emission of transmitter	dBm	25 to 40,000 MHz	± 0.7 dB
Conducted emission of receiver	dBm	25 to 40,000 MHz	± 0.7 dB
Radiated emission (substitution method)	dBm	25 to 40,000 MHz	± 2.5 dB
Radiated emission (field strength)	dBμV/m	25 to 1,000 MHz 1 to 40 GHz	± 3.6 dB ± 6.0 dB

EQUIPMENT UNDER TEST (EUT) DETAILS**GENERAL**

The GE MDS LLC model LN400 is an industrial radio module operating in the 406.1-470 MHz bands and uses QAM modulation. Since the EUT could be placed in any position during operation, the EUT was treated as table-top equipment during testing to simulate the end-user environment. The electrical rating of the EUT is 10.0-60.0 Volts DC, 2.5 Amps max.

The sample was received on March 9, 2015 and tested on March 9, April 27, 28, 29, 30 and May 1, 2015. The EUT consisted of the following component(s):

Company	Model	Description	Serial Number	FCC ID
GE MDS LLC	LN400	Industrial Radio Module	2648639	E5MDS-LN400

OTHER EUT DETAILS

The following EUT details should be noted: The host "Orbit" product platform in which this product will be used is rated for -40C to +70C, 10-60VDC input.

ENCLOSURE

The EUT does not have an enclosure as it is intended to be installed in a complete product. The PCB measures approximately 3.8 cm wide by 8.9 cm deep by 0.6 cm high.

MODIFICATIONS

No modifications were made to the EUT during the time the product was at National Technical Systems - Silicon Valley.

SUPPORT EQUIPMENT

The following equipment was used as support equipment for testing:

Company	Model	Description	Serial Number	FCC ID
HP	6024A	DC Power Supply	104129	-

The following equipment was used as remote support equipment for emissions testing:

Company	Model	Description	Serial Number	FCC ID
HP	DV6000	Laptop	CNF73411TR	-

EUT INTERFACE PORTS

The I/O cabling configuration during testing was as follows:

Port	Connected To	Description	Cable(s)	
			Shielded or Unshielded	Length(m)
RF out	TNC-N connector	Direct connect	-	-
TNC-N connector	20 dB pad 10 W	Attenuator	-	-
20 dB pad	PSA	Direct connect	-	-
DC Power	DC power supply	DC mains	Unshielded	1

Additional on Support Equipment:

Port	Connected To	Description	Cable(s)	
			Shielded or Unshielded	Length(m)
Serial DB9	Laptop USB	DB9 to USB converter	Shielded	1

EUT OPERATION

During emissions testing the EUT was set to transmit at maximum and minimum power or in receive mode on the selected channel.

TESTING**GENERAL INFORMATION**

Antenna port measurements were taken at the National Technical Systems - Silicon Valley test site located at 41039 Boyce Road, Fremont, CA 94538-2435.

Radiated spurious emissions measurements were taken at the National Technical Systems - Silicon Valley Anechoic Chamber(s) listed below. The sites conform to the requirements of ANSI C63.4: 2013 *American National Standard for Methods of Measurement of Radio-Noise Emissions from Low-Voltage Electrical and Electronic Equipment in the Range of 9 kHz to 40 GHz* and CISPR 16-1-4:2007 - *Specification for radio disturbance and immunity measuring apparatus and methods Part 1-4: Radio disturbance and immunity measuring apparatus Ancillary equipment Radiated disturbances*. They are on file with the FCC and industry Canada.

Site	Designation / Registration Numbers		Location
	FCC	Canada	
Chamber 3	US0027	IC 2845B-3	41039 Boyce Road Fremont, CA 94538-2435

Considerable engineering effort has been expended to ensure that the facilities conform to all pertinent requirements.

RF PORT MEASUREMENT PROCEDURES

Conducted measurements are performed with the EUT's rf input/output connected to the input of a spectrum analyzer, power meter or modulation analyzer. When required an attenuator, filter and/or dc block is placed between the EUT and the spectrum analyzer to avoid overloading the front end of the measurement device. Measurements are corrected for the insertion loss of the attenuators and cables inserted between the rf port of the EUT and the measurement equipment.

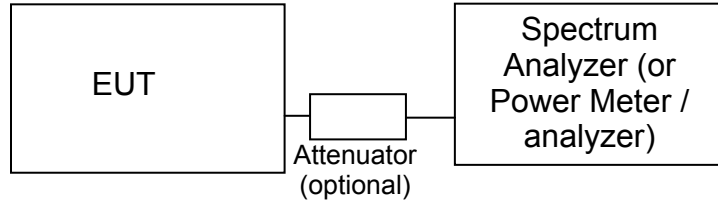

Test Configuration for Antenna Port Measurements

For devices with an integral antenna the output power and spurious emissions are measured as a field strength at a test distance of (typically) 3m and then converted to an eirp using a substitution measurement (refer to RADIATED EMISSIONS MEASUREMENTS). All other measurements are made as detailed below but with the test equipment connected to a measurement antenna directed at the EUT.

OUTPUT POWER

Output power is measured using a spectrum analyzer with positive peak detector. Resolution bandwidth is set to > emission bandwidth

Power measurements made directly on the rf power port are, when appropriate, converted to an ERP by adding the gain of the highest gain antenna that can be used with the device under test, as specified by the manufacturer.

BANDWIDTH MEASUREMENTS

The 6dB, 20dB and/or 26dB signal bandwidth is measured in using the bandwidths recommended by ANSI C63.4. When required, the 99% bandwidth is measured using the methods detailed in RSS-GEN. The measurement bandwidth is set to be 1 % to 5 % of the occupied bandwidth.

CONDUCTED SPURIOUS EMISSIONS

Initial scans are made using a peak detector (RBW=VBW) and using scan rates to ensure that the EUT transmits before the sweep moves out of each resolution bandwidth (for transmit mode measurements). Where the limits are expressed as an average power the spectrum analyzer is tuned to that frequency with a narrow span (wide enough to capture the emission and its sidebands) and the resolution and video bandwidths are adjusted as required by the reference measurement standards. For transmitter measurements the appropriate detector (average, peak, normal, sample, quasi-peak) is used when making measurements for licensed devices. For receiver conducted spurious measurements the detector is set to peak.

TRANSMITTER MASK MEASUREMENTS

The transmitter mask measurements are made using resolution bandwidths as specified in the pertinent rule part(s). Where narrower bandwidths are used the measurement is corrected to account for the reduced bandwidth by either using the adjacent channel power function of the spectrum analyzer to sum the power across the required measurement bandwidth. The frequency span of the analyzer is set to ensure the fundamental signal and all significant sidebands are displayed.

The top of the mask may be set by the total output power of the signal, the power of the unmodulated signal or the peak value of the signal in the reference bandwidth being used for the mask measurement.

FREQUENCY STABILITY

The EUT is placed inside a temperature chamber with all support and test equipment located outside of the chamber. The temperature is varied across the specified frequency range in 10 degree increments with frequency measurements made at each temperature step. The EUT is allowed enough time to stabilize at each temperature variation.

The spectrum analyzer is configured to give a 5- or 6-digit display for the marker-frequency function. The frequency drift is determined by finding a stable point on the signal (e.g. the null at the centre of an OFDM signal) or by calculating a centre frequency based on the upper and lower xdB points (where x is typically 10 dB or 99 % power bandwidth) on the signal's skirts.

TRANSIENT FREQUENCY BEHAVIOR:

The TIA/EIA 603 procedure is used to determine compliance with transient frequency timing requirements as the radio is keyed on and off.

The EUTs rf output is connected via a combiner/splitter to the test receiver/spectrum analyzer and to a diode detector. The test receiver or spectrum analyzer video output is connected to an oscilloscope, which is triggered by the output from the diode detector.

Plots showing Ton, T1, and T2 are made when turning on the transmitter and showing T3 when turning off the transmitter.

RADIATED EMISSIONS MEASUREMENTS

Receiver radiated spurious emissions measurements are made in accordance with ANSI C63.4 by measuring the field strength of the emissions from the device at a specific test distance and comparing them to a field strength limit. Where the field strength limit is specified at a longer distance than the measurement distance the measurement is extrapolated to the limit distance.

Transmitter radiated spurious emissions are initially measured as a field strength. The eirp or erp limit as specified in the relevant rule part(s) is converted to a field strength at the test distance and the emissions from the EUT are then compared to that limit. Emissions within 20 dB of this limit are the subjected to a substitution measurement.

All radiated emissions measurements are performed in two phases. A preliminary scan of emissions is conducted in either an anechoic chamber or on an OATS during which all significant EUT frequencies are identified with the system in a nominal configuration. At least two scans are performed across the complete frequency range of interest and at each operating frequency identified in the reference standard. One or more of these is with the antenna polarized vertically while the one or more of these is with the antenna polarized horizontally. Initial scans are made using a peak detector (RBW=VBW) and using scan rates to ensure that the EUT transmits before the sweep moves out of each resolution bandwidth (for transmit mode).

During the preliminary scans, the EUT is rotated through 360°, the antenna height is varied and cable positions are varied to determine the highest emission relative to the limit. For transmitter spurious emissions, where the limit is expressed as an effective radiated power, the eirp or erp is converted to a field strength limit.

Final measurements are made on an OATS or in a semi-anechoic chamber at the significant frequencies observed during the preliminary scan(s) using the same process of rotating the EUT and raising/lowering the measurement antenna to find the highest level of the emission. The field strength is recorded and, for receiver spurious emissions, compared to the field strength limit. For the final measurement the appropriate detectors (average, peak, normal, sample, quasi-peak) are used. For receiver measurements below 1GHz the detector is a Quasi-Peak detector, above 1GHz a peak detector is used and the peak value (RB=VB=1MHz) and average value (RB=1MHz, VB=10Hz) are recorded.

For transmitter spurious emissions, the radiated power of all emissions within 20dB of the calculated field strength limit are determined using a substitution measurement. The substitution measurement is made by replacing the EUT with an antenna of known gain (typically a dipole antenna or a double-ridged horn antenna), connected to a signal source. The output power of the signal generator is adjusted until the maximum field strength from the substitution antenna is similar to the field strength recorded from the EUT. The erp of the EUT is then calculated.

INSTRUMENTATION

An EMI receiver as specified in CISPR 16-1-1 is used for radiated emissions measurements. The receivers used can measure over the frequency range of 9 kHz up to 7000 MHz. These receivers allow both ease of measurement and high accuracy to be achieved. The receivers have Peak, Average, and CISPR (Quasi-peak) detectors built into their design so no external adapters are necessary.

For measurements above the frequency range of the receivers and for all conducted measurements a spectrum analyzer is utilized because it provides visibility of the entire spectrum along with the precision and versatility required to support engineering analysis.

Measurement bandwidths for the test instruments are set in accordance with the requirements of the standards referenced in this document.

Software control is used to correct the measurements for transducer factors (e.g. antenna) and the insertion loss of cables, attenuators and other series elements to obtain the final measurement value. This provides faster, more accurate readings by performing the conversions described under Sample Calculations within the Test Procedures section of this report. Results are exported in a graphic and/or tabular format, as appropriate.

FILTERS/ATTENUATORS

External filters and precision attenuators are often connected between the EUT antenna port or receiving antenna and the test receiver. This eliminates saturation effects and non-linear operation due to high amplitude transient events.

ANTENNAS

A combination of biconical, log periodic or bi-log antennas are used to cover the range from 30 MHz to 1000 MHz. Broadband antennas or tuned dipole antennas are used over the entire 25 MHz to 1000 MHz frequency range as the reference antenna for substitution measurements.

Above 1000 MHz, a dual-ridge guide horn antenna or octave horn antenna are used as reference and measurement antennas.

The antenna calibration factors are included in site factors that are programmed into the test receivers and instrument control software when measuring the radiated field strength.

ANTENNA MAST AND EQUIPMENT TURNTABLE

The antennas used to measure the radiated electric field strength are mounted on a non-conductive antenna mast equipped with a motor-drive to vary the antenna height.

Table mounted devices are placed on a non-conductive table at a height of 80 centimeters above the floor. Floor mounted equipment is placed on the ground plane if the device is normally used on a conductive floor or separated from the ground plane by insulating material from 3 to 12 mm if the device is normally used on a non-conductive floor. The EUT is positioned on a motorized turntable to allow it to be rotated during testing to determine the angle with the highest level of emissions.

SAMPLE CALCULATIONS

SAMPLE CALCULATIONS - CONDUCTED SPURIOUS EMISSIONS

Measurements are compared directly to the conducted emissions specification limit (decibel form). The calculation is as follows:

$$R_r - S = M$$

where:

R_r = Measured value in dBm

S = Specification Limit in dBm

M = Margin to Specification in +/- dB

SAMPLE CALCULATIONS - RADIATED FIELD STRENGTH

Measurements of radiated field strength are compared directly to the specification limit (decibel form). The receiver and/or control software corrects for cable loss, preamplifier gain, and antenna factor. The calculations are in the reverse direction of the actual signal flow, thus cable loss is added and the amplifier gain is subtracted. The Antenna Factor converts the voltage at the antenna coaxial connector to the field strength at the antenna elements.

A distance factor is used when measurements are made at a test distance that is different to the specified limit distance by using the following formula:

$$F_d = 20 * \text{LOG}_{10} (D_m/D_s)$$

where:

F_d = Distance Factor in dB

D_m = Measurement Distance in meters

D_s = Specification Distance in meters

For electric field measurements below 30 MHz the extrapolation factor is either determined by making measurements at multiple distances or a theoretical value is calculated using the formula:

$$F_d = 40 * \text{LOG}_{10} (D_m/D_s)$$

The margin of a given emission peak relative to the limit is calculated as follows:

$$R_c = R_r + F_d$$

and

$$M = R_c - L_s$$

where:

R_r = Receiver Reading in dB μ V/m

F_d = Distance Factor in dB

R_c = Corrected Reading in dB μ V/m

L_s = Specification Limit in dB μ V/m

M = Margin in dB Relative to Spec

SAMPLE CALCULATIONS –RADIATED POWER

The erp/eirp limits for transmitter spurious measurements are converted to a field strength in free space using the following formula:

$$E = \frac{\sqrt{30 P G}}{d}$$

where:

- E = Field Strength in V/m
- P = Power in Watts
- G = Gain of isotropic antenna (numeric gain) = 1
- D = measurement distance in meters

The field strength limit is then converted to decibel form (dBuV/m) and the margin of a given emission peak relative to the limit is calculated (refer to *SAMPLE CALCULATIONS –RADIATED FIELD STRENGTH*).

When substitution measurements are required (all signals with less than 20dB of margin relative to the calculated field strength limit) the eirp of the spurious emission is calculated using:

$$P_{EUT} = P_S - (E_S - E_{EUT})$$

and

$$P_S = G + P_{in}$$

where:

- P_S = effective isotropic radiated power of the substitution antenna (dBm)
- P_{in} = power input to the substitution antenna (dBm)
- G = gain of the substitution antenna (dBi)
- E_S = field strength the substitution antenna (dBm) at eirp P_S
- E_{EUT} = field strength measured from the EUT

Where necessary the effective isotropic radiated power is converted to effective radiated power by subtracting the gain of a dipole (2.2 dBi) from the eirp value.

RECEIVER RADIATED SPURIOUS EMISSIONS SPECIFICATION LIMITS

The table below shows the limits for the spurious emissions from receivers as detailed in FCC Part 15.109, RSS-210 Table 2, RSS-GEN Table 1 and RSS-310 Table 3. Note that receivers operating outside of the frequency range 30 MHz – 960 MHz are exempt from the requirements of 15.109.

Frequency Range (MHz)	Limit ($\mu\text{V/m @ 3m}$)	Limit ($\text{dB}\mu\text{V/m @ 3m}$)
30 to 88	100	40
88 to 216	150	43.5
216 to 960	200	46.0
Above 960	500	54.0

Appendix A Test Equipment Calibration Data

<u>Manufacturer</u>	<u>Description</u>	<u>Model</u>	<u>Asset #</u>	<u>Calibrated</u>	<u>Cal Due</u>
Radio Antenna Port, 09-Mar-15					
Rohde & Schwarz	Signal Analyzer 20 Hz - 26.5 GHz	FSQ26	2327	4/28/2014	4/28/2015
Radiated Emissions, 30 - 5,000 MHz, 09-Mar-15					
Rohde & Schwarz	EMI Test Receiver, 20 Hz-7 GHz	ESIB7	1630	6/21/2014	6/21/2015
Sunol Sciences	Biconilog, 30-3000 MHz	JB3	2237	8/29/2014	8/29/2016
EMCO	Antenna, Horn, 1-18 GHz	3115	2870	8/20/2013	8/20/2015
Com-Power	Preamplifier, 1-1000 MHz	PAM-103	2885	10/22/2014	10/22/2015
Filtek	Filter, 1 GHz High Pass	HP12/1000-5BA	955	5/13/2014	5/13/2015
Antenna port measurements, 27-Apr-15					
Agilent Technologies	PSA, Spectrum Analyzer, (installed options, 111, 115, 123, 1DS, B7J, HYG,	E4446A	2139	4/8/2015	4/8/2016
Antenna port measurements, 28-Apr-15					
Filtek	Filter, 1 GHz High Pass	HP12/1000-5BA	957	5/14/2014	5/14/2015
Agilent Technologies	PSA, Spectrum Analyzer, (installed options, 111, 115, 123, 1DS, B7J, HYG,	E4446A	2139	4/8/2015	4/8/2016
Transient frequency behavior, 28-Apr-15					
Rohde & Schwarz	Test Receiver, 20-1300 MHz	ESVP	213	7/31/2014	7/31/2015
Tektronix	1 GHz, 4 CH, 5GS/s Oscilloscope	TDS5104	1435	8/1/2014	8/1/2015
Rohde & Schwarz	signal generator 100KHz-12.75GHz	SMB 100A	3002	4/28/2014	4/28/2015
Frequency Stability, 28-Apr-15					
Fluke	Fluke True RMS Multimeter	111	1557	3/30/2015	3/30/2016
Agilent Technologies	PSA, Spectrum Analyzer, (installed options, 111, 115, 123, 1DS, B7J, HYG,	E4446A	2139	4/8/2015	4/8/2016
Watlow	Temp Chamber (w/ F4 Watlow Controller)	F4	2170	7/18/2014	7/18/2015
EN Extremes, 29-Apr-15					
Rohde & Schwarz	Power Meter, Single Channel	NRVS	1422	1/22/2015	1/22/2016
Rohde & Schwarz	Power Sensor 100 uW - 2 Watts (w/ 20 dB pad, SN BJ5155)	NRV-Z32	1536	1/15/2015	1/15/2016
Agilent Technologies	PSA, Spectrum Analyzer, (installed options, 111, 115, 123, 1DS, B7J, HYG,	E4446A	2139	4/8/2015	4/8/2016
Watlow	Temp Chamber (w/ F4 Watlow Controller)	F4	2170	7/18/2014	7/18/2015
Radio Antenna Port (Power and Spurious Emissions), 29-Apr-15					
Agilent Technologies	PSA, Spectrum Analyzer, (installed options, 111, 115, 123, 1DS, B7J, HYG,	E4446A	2139	4/8/2015	4/8/2016

<u>Manufacturer</u>	<u>Description</u>	<u>Model</u>	<u>Asset #</u>	<u>Calibrated</u>	<u>Cal Due</u>
Agilent Technologies	PSG, Vector Signal Generator, (250kHz - 20MHz)	E8267D	3011	1/8/2015	1/8/2016
Radiated Emissions, 30 - 12,750 MHz, 29-Apr-15					
EMCO	Antenna, Horn, 1-18 GHz	3115	786	12/20/2013	12/20/2015
Hewlett Packard	Microwave Preamplifier, 1-26.5GHz	8449B	870	2/20/2015	2/20/2016
Hewlett Packard	SpecAn 30 Hz -40 GHz, SV (SA40) Red	8564E (84125C)	1148	9/20/2014	9/20/2015
Sunol Sciences	Biconilog, 30-3000 MHz	JB3	1657	6/25/2014	6/25/2016
Rohde & Schwarz	EMI Test Receiver, 20 Hz-7 GHz	ESIB7	1756	6/14/2014	6/14/2015
Com-Power	Preamplifier, 30-1000 MHz	PA-103	2465	9/11/2014	9/11/2015
Radiated Emissions, 1 - 5 GHz, 30-Apr-15					
EMCO	Antenna, Horn, 1-18 GHz	3115	786	12/20/2013	12/20/2015
Hewlett Packard	Microwave Preamplifier, 1-26.5GHz	8449B	870	2/20/2015	2/20/2016
Filtek	Filter, 1 GHz High Pass	HP12/1000-5BA	955	5/13/2014	5/13/2015
Hewlett Packard	SpecAn 30 Hz -40 GHz, SV (SA40) Red	8564E (84125C)	1148	9/20/2014	9/20/2015
Radiated Emissions, 30 - 2,000 MHz, 01-May-15					
EMCO	Antenna, Horn, 1-18 GHz	3115	487	7/29/2014	7/29/2016
Hewlett Packard	Microwave Preamplifier, 1-26.5GHz	8449B	785	10/31/2014	10/31/2015
Hewlett Packard	SpecAn 9 kHz - 40 GHz, FT (SA40) Blue	8564E (84125C)	1393	5/6/2014	5/6/2015
Sunol Sciences	Biconilog, 30-3000 MHz	JB3	1657	6/25/2014	6/25/2016
Rohde & Schwarz	EMI Test Receiver, 20 Hz-7 GHz	ESIB7	1756	6/14/2014	6/14/2015
Com-Power	Preamplifier, 30-1000 MHz	PA-103	2465	9/11/2014	9/11/2015
Conducted Emissions - AC Power Ports, 01-May-15					
EMCO	LISN, 10 kHz-100 MHz	3825/2	1293	2/13/2014	5/13/2015
Rohde & Schwarz	Pulse Limiter	ESH3 Z2	1401	5/15/2014	5/15/2015
Rohde & Schwarz	EMI Test Receiver, 20 Hz-7 GHz	ESIB7	1756	6/14/2014	6/14/2015



Appendix B Test Data

T97716 Pages 22 - 75



EMC Test Data

Client:	GE MDS LLC	Job Number:	J97704
Product	LN400	T-Log Number:	T97706
		Project Manager:	Christine Krebill
Contact:	Dennis McCarthy	Project Coordinator:	-
Emissions Standard(s):	FCC Part 15, FCC Part 90, EN 300 113-2	Class:	A
Immunity Standard(s):	-	Environment:	Radio

EMC Test Data

For The

GE MDS LLC

Product

LN400

Date of Last Test: 6/9/2015



EMC Test Data

Client:	GE MDS LLC	Job Number:	J97704
Model:	LN400	T-Log Number:	T97706
		Project Manager:	Christine Krebill
Contact:	Dennis McCarthy	Project Coordinator:	-
Standard:	FCC Part 15, FCC Part 90, EN 300 113-2	Class:	A

RSS 119 and FCC Part 90 Power, Occupied Bandwidth, Frequency Stability and Spurious Emissions

Test Specific Details

Objective: The objective of this test session is to perform final qualification testing of the EUT with respect to the specification listed above.

General Test Configuration

With the exception of the radiated spurious emissions tests, all measurements are made with the EUT's rf port connected to the measurement instrument via an attenuator or dc-block if necessary. All amplitude measurements are adjusted to account for the attenuation between EUT and measuring instrument. For frequency stability measurements the EUT was placed inside an environmental chamber.

Radiated measurements are made with the EUT located on a non-conductive table, 3m from the measurement antenna.

Ambient Conditions: Temperature: 20-22 °C
 Rel. Humidity: 30-45 %

Summary of Results

Run #	Spacing	Data Rate	Test Performed	Limit	Pass / Fail	Result / Margin
1	-	-	Output Power	Determined at time of Licensing	Pass	High: 41.2 dBm Low: 19.6 dBm
2	6.25 kHz, 12.5 kHz, 25.0 kHz	4.8, 9.6, 10.0, 16.0, 20.0 ksps	Spectral Mask and ACP	Masks C, D, E, Y (IC) and ACP (FCC) limits.	Pass	Pass
3	6.25 kHz, 12.5 kHz, 25.0 kHz	4.8, 9.6, 10.0, 16.0, 20.0 ksps	99% or Occupied Bandwidth	-	-	5.16 kHz, 10.3 kHz, 10.8 kHz, 17.2 kHz, 21.4 kHz
4	6.25 kHz	4.8 ksps	Spurious Emissions (conducted)	-25 dBm (Mask E, worst case)	Pass	-25.7 dBm @ 305.37 MHz (-0.7 dB)
5	6.25 kHz	4.8 ksps	Spurious emissions (radiated)	-25 dBm ERP	Pass	-31.6 dBm erp @ 1290.0 MHz (-6.6 dB)
6	-	-	Transient Frequency Behavior	FCC Part 90.214 and RSS-119 Table 17	Pass	Pass
7	6.25 kHz	4.8 ksps	Frequency Stability	0.5 ppm	Pass	Pass / 0.1 ppm

Modifications Made During Testing

No modifications were made to the EUT during testing

Deviations From The Standard

No deviations were made from the requirements of the standard.

Client: GE MDS LLC	Job Number: J97704
Model: LN400	T-Log Number: T97706
Contact: Dennis McCarthy	Project Manager: Christine Krebill
Standard: FCC Part 15, FCC Part 90, EN 300 113-2	Project Coordinator: -
	Class: A

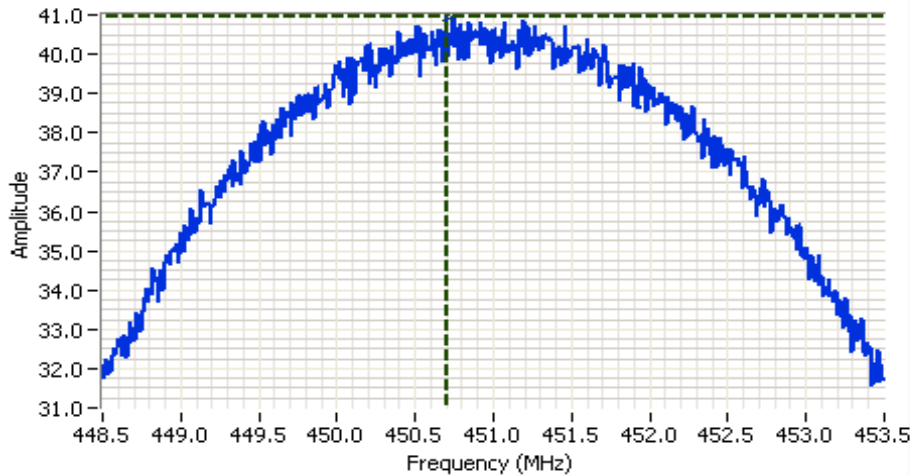

Analyzer Settings
 Agilent Technologies, E4446A
 CF: 451.000 MHz
 SPAN: 5.000 MHz
 RB: 3.000 MHz
 VB: 8.000 MHz
 Detector: POS
 Attn: 40 DB
 RL Offset: 20.0 DB
 Sweep Time: 0.5s
 Ref Lvl: 50.0 DBM

Comments
 4QAM, 4.8 ksp
 High power

Cursor 1 450.7000 41.0 

0.0000 0.0 

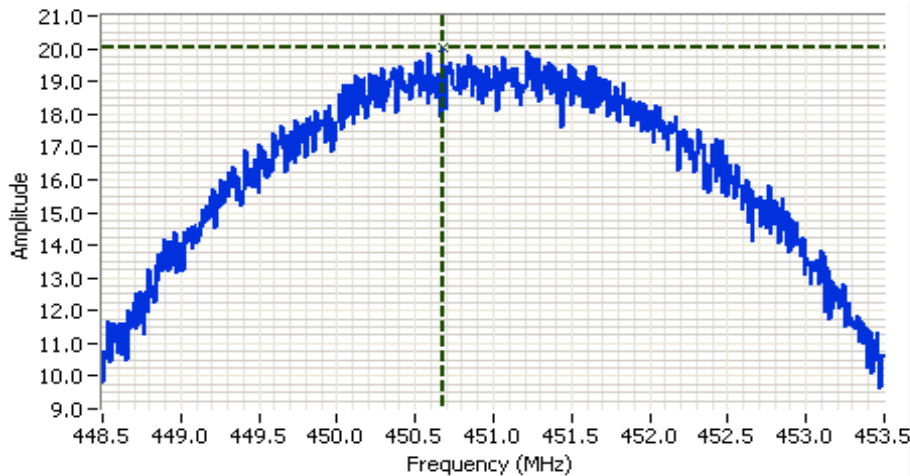

Analyzer Settings
 Agilent Technologies, E4446A
 CF: 451.000 MHz
 SPAN: 5.000 MHz
 RB: 3.000 MHz
 VB: 8.000 MHz
 Detector: POS
 Attn: 20 DB
 RL Offset: 20.0 DB
 Sweep Time: 0.5s
 Ref Lvl: 30.0 DBM

Comments
 4QAM, 4.8 ksp
 Low power

Cursor 1 450.6750 20.0 

0.0000 0.0 





EMC Test Data

Client: GE MDS LLC	Job Number: J97704
Model: LN400	T-Log Number: T97706
Contact: Dennis McCarthy	Project Manager: Christine Krebill
Standard: FCC Part 15, FCC Part 90, EN 300 113-2	Project Coordinator: -
	Class: A

Run #2: Spectral Mask, FCC Part 90 Masks C, D, E, Y (RSS-119) and ACP (FCC 90.221)
 Date of Test: 27-Apr-15 Config. Used: 1
 Test Engineer: Deniz Demirci Config Change: none
 Test Location: FT Lab #4 EUT Voltage: 13.8 VDC

- Note 1: 451 MHz peak power measurements were used as a spectral mask power reference.
- Note 2: 4QAM modulation has the worst case spectral mask results at 6.25 kHz BW of operations hence 4QAM was used for 12.5 kHz (9.6 ksp/s and 10 ksp/s) and 25 kHz (16 ksp/s and 20 ksp/s) BW of operations.

Modulations = 4QAM, 16QAM, 64QAM

20 ksp/s is for 450 MHz to 470 MHz operations only. (EUT does not operate with 20 ksp/s at 406.1 - 430 MHz range)

4.8 ksp/s: 6.25 kHz BW (Mask E)

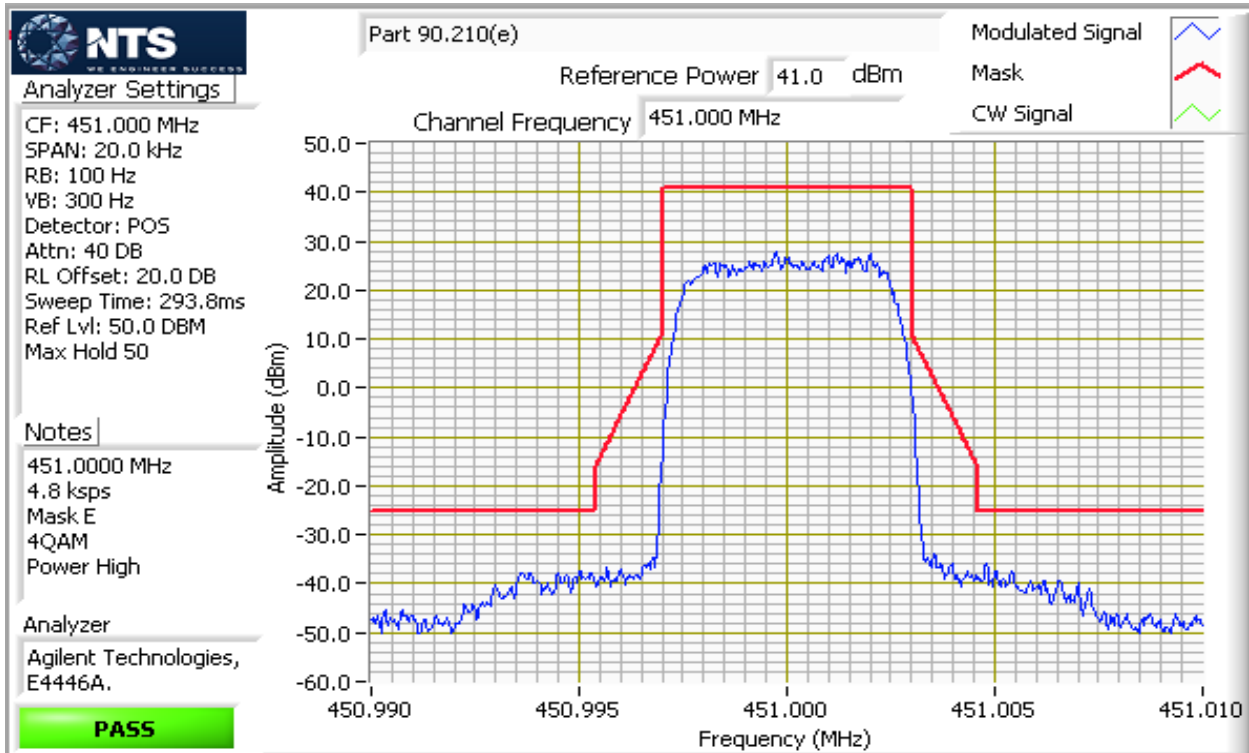

Client: GE MDS LLC	Job Number: J97704
Model: LN400	T-Log Number: T97706
Contact: Dennis McCarthy	Project Manager: Christine Krebill
Standard: FCC Part 15, FCC Part 90, EN 300 113-2	Project Coordinator: -
	Class: A

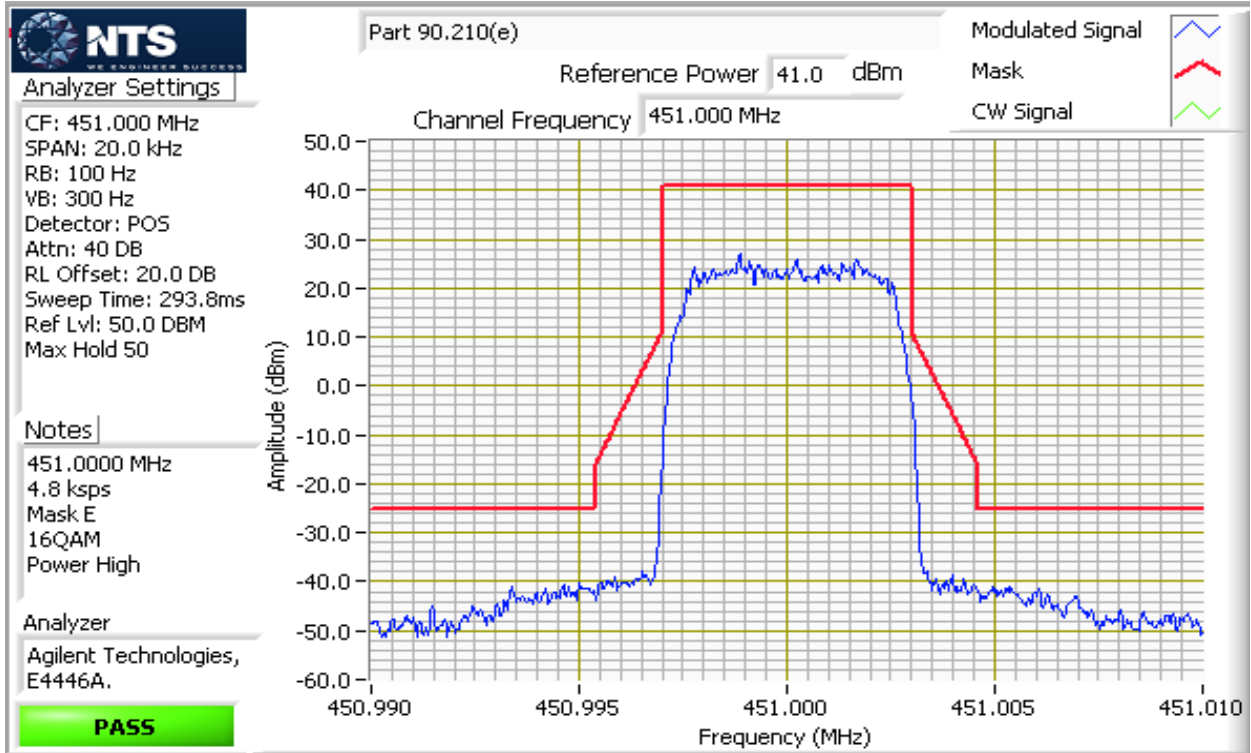

Client: GE MDS LLC	Job Number: J97704
Model: LN400	T-Log Number: T97706
	Project Manager: Christine Krebill
Contact: Dennis McCarthy	Project Coordinator: -
Standard: FCC Part 15, FCC Part 90, EN 300 113-2	Class: A

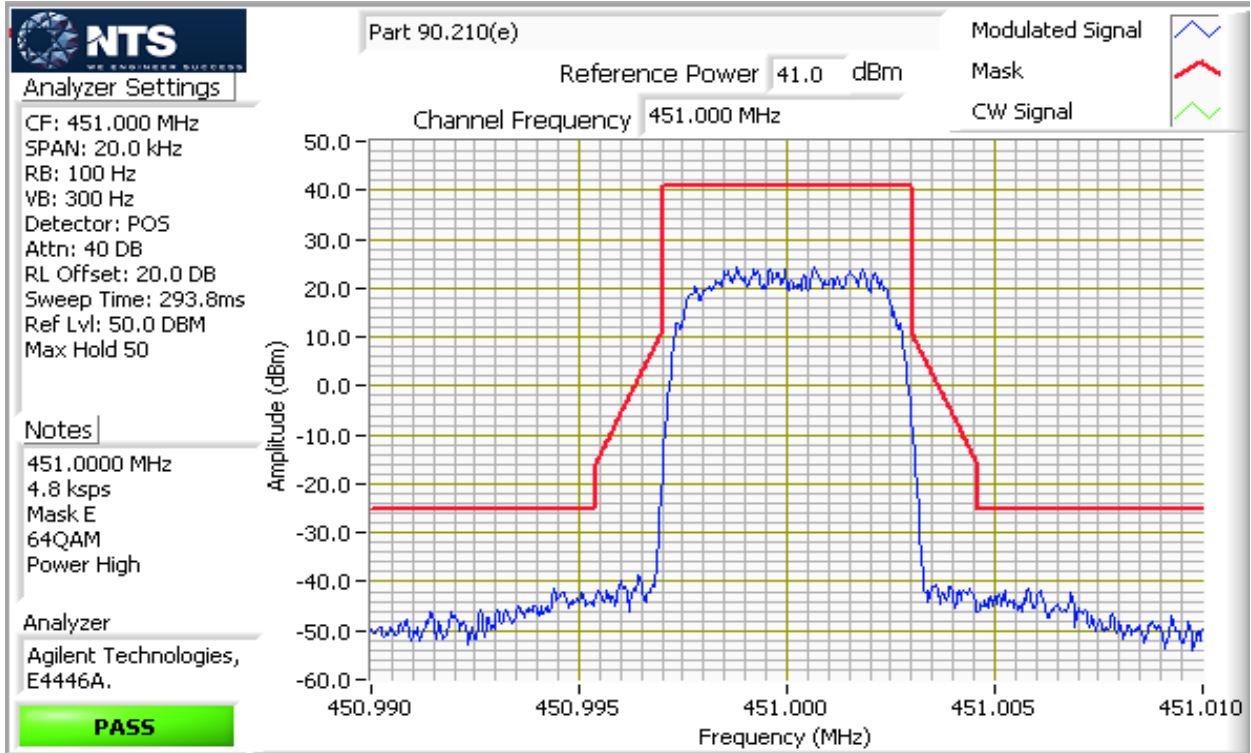



EMC Test Data

Client: GE MDS LLC	Job Number: J97704
Model: LN400	T-Log Number: T97706
Contact: Dennis McCarthy	Project Manager: Christine Krebill
Standard: FCC Part 15, FCC Part 90, EN 300 113-2	Project Coordinator: -
	Class: A

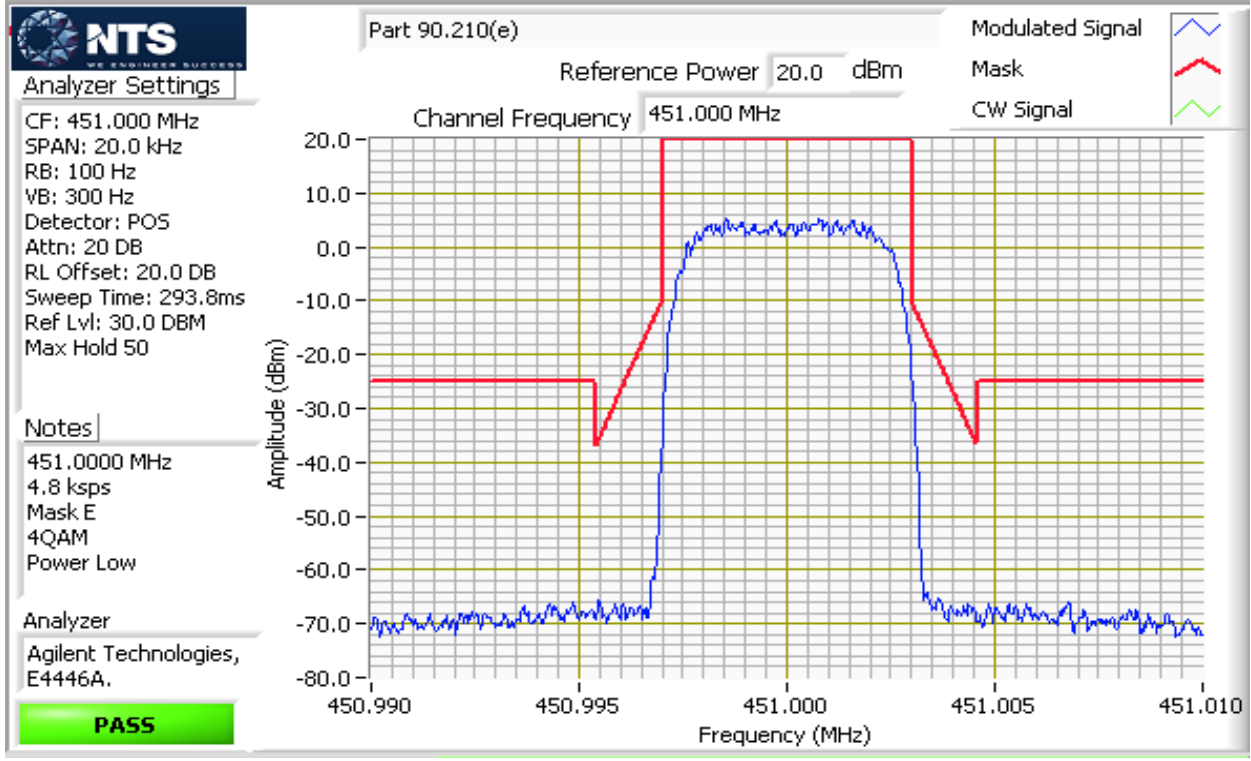

Client: GE MDS LLC	Job Number: J97704
Model: LN400	T-Log Number: T97706
Contact: Dennis McCarthy	Project Manager: Christine Krebill
Standard: FCC Part 15, FCC Part 90, EN 300 113-2	Project Coordinator: -
	Class: A

9.6 ksps and 10 ksps: 12.5 kHz BW (Mask D)

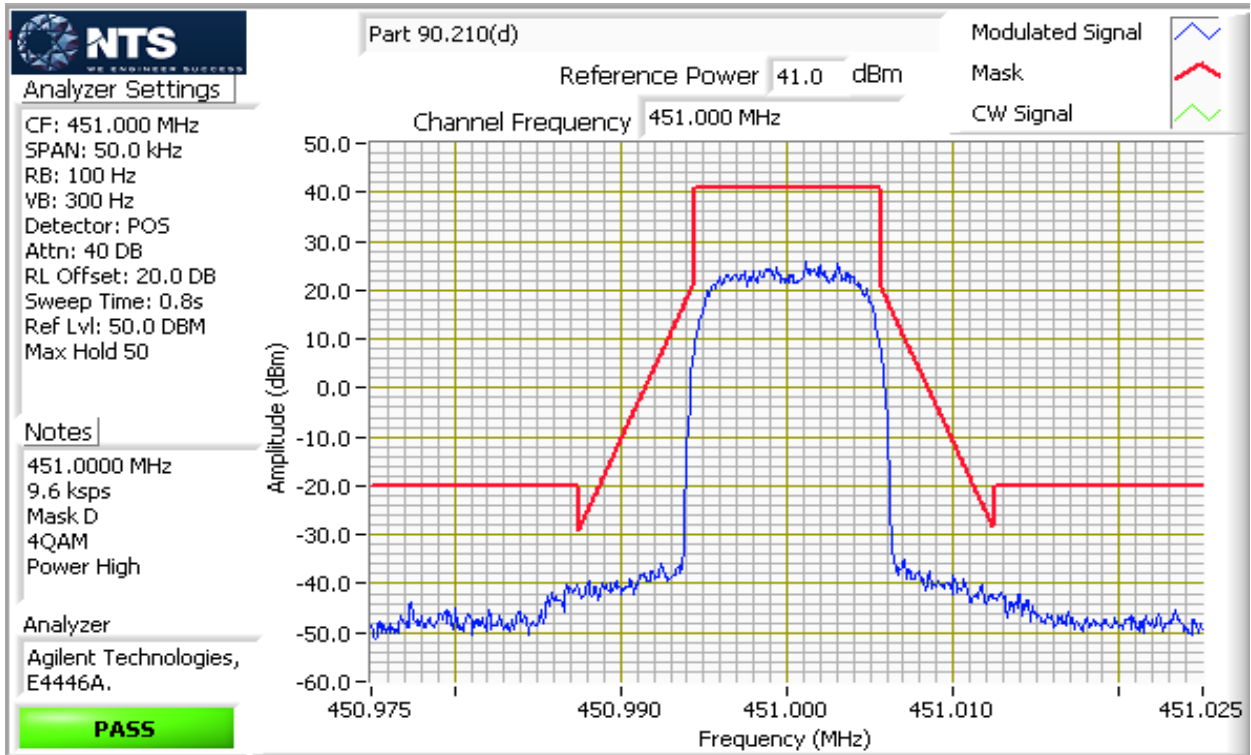

Client: GE MDS LLC	Job Number: J97704
Model: LN400	T-Log Number: T97706
	Project Manager: Christine Krebill
Contact: Dennis McCarthy	Project Coordinator: -
Standard: FCC Part 15, FCC Part 90, EN 300 113-2	Class: A

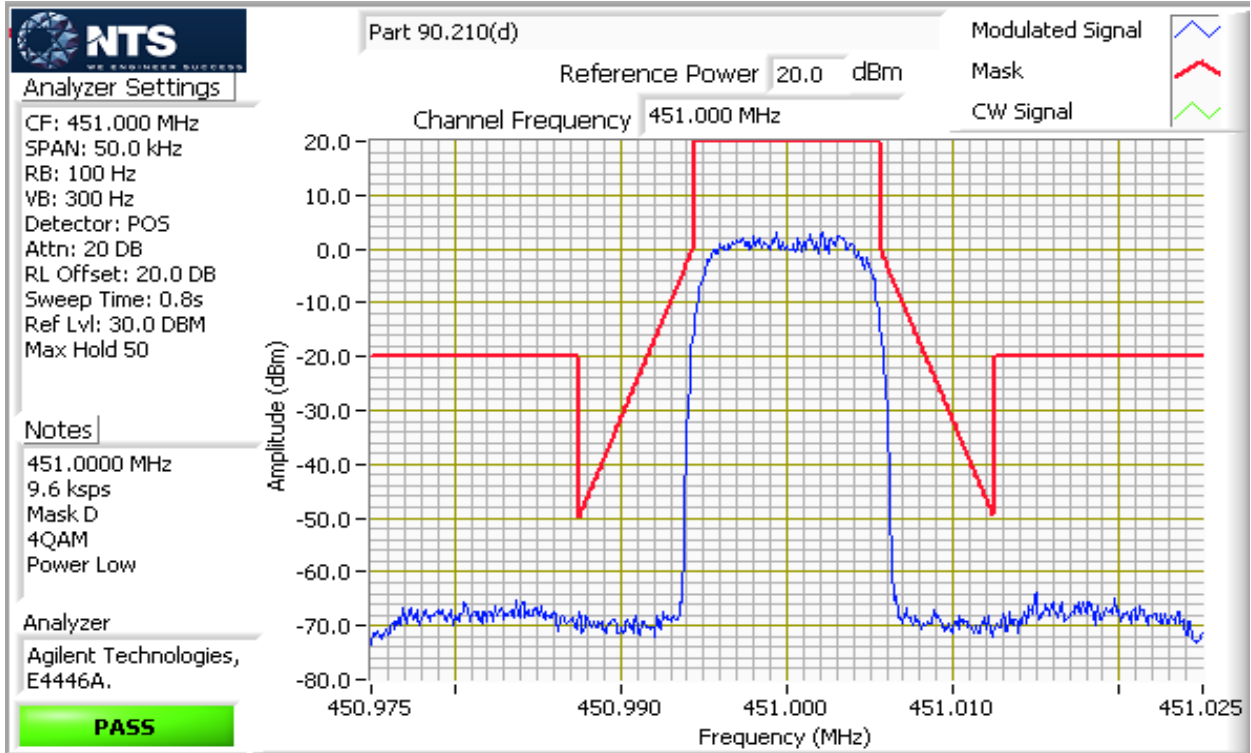



EMC Test Data

Client: GE MDS LLC	Job Number: J97704
Model: LN400	T-Log Number: T97706
Contact: Dennis McCarthy	Project Manager: Christine Krebill
Standard: FCC Part 15, FCC Part 90, EN 300 113-2	Project Coordinator: -
	Class: A

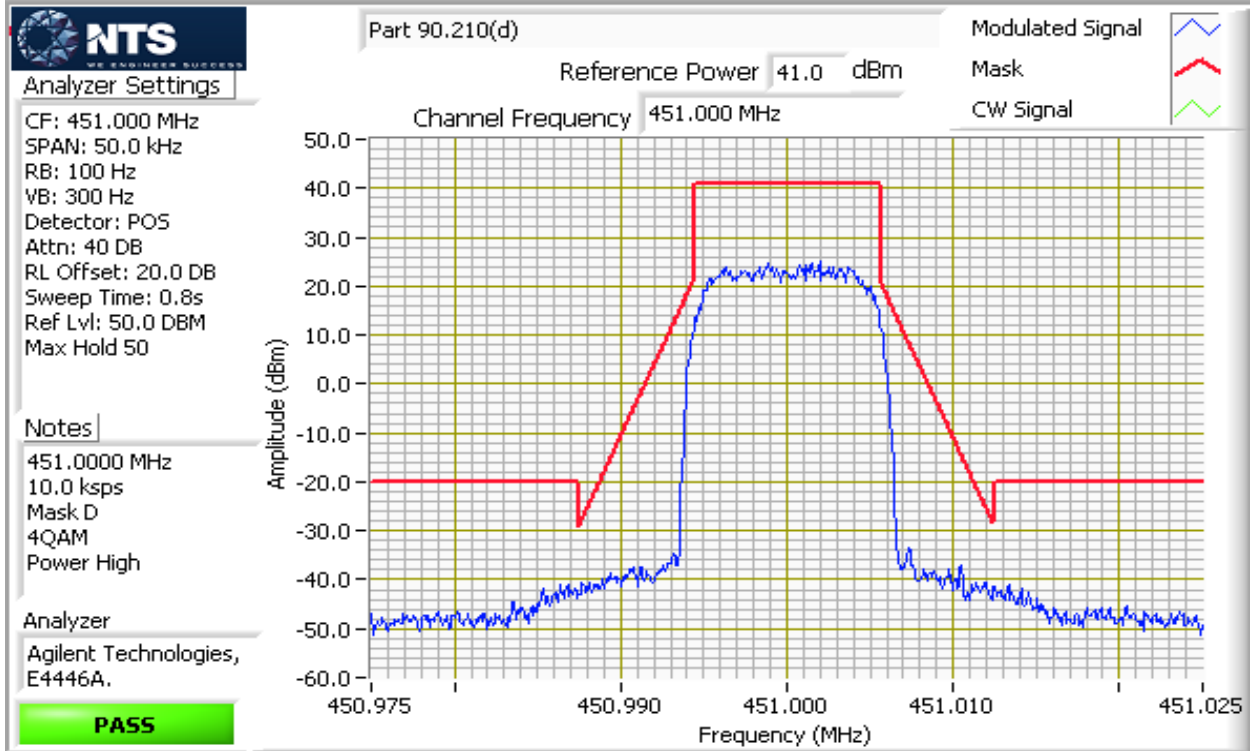

Client: GE MDS LLC	Job Number: J97704
Model: LN400	T-Log Number: T97706
Contact: Dennis McCarthy	Project Manager: Christine Krebill
Standard: FCC Part 15, FCC Part 90, EN 300 113-2	Project Coordinator: -
	Class: A

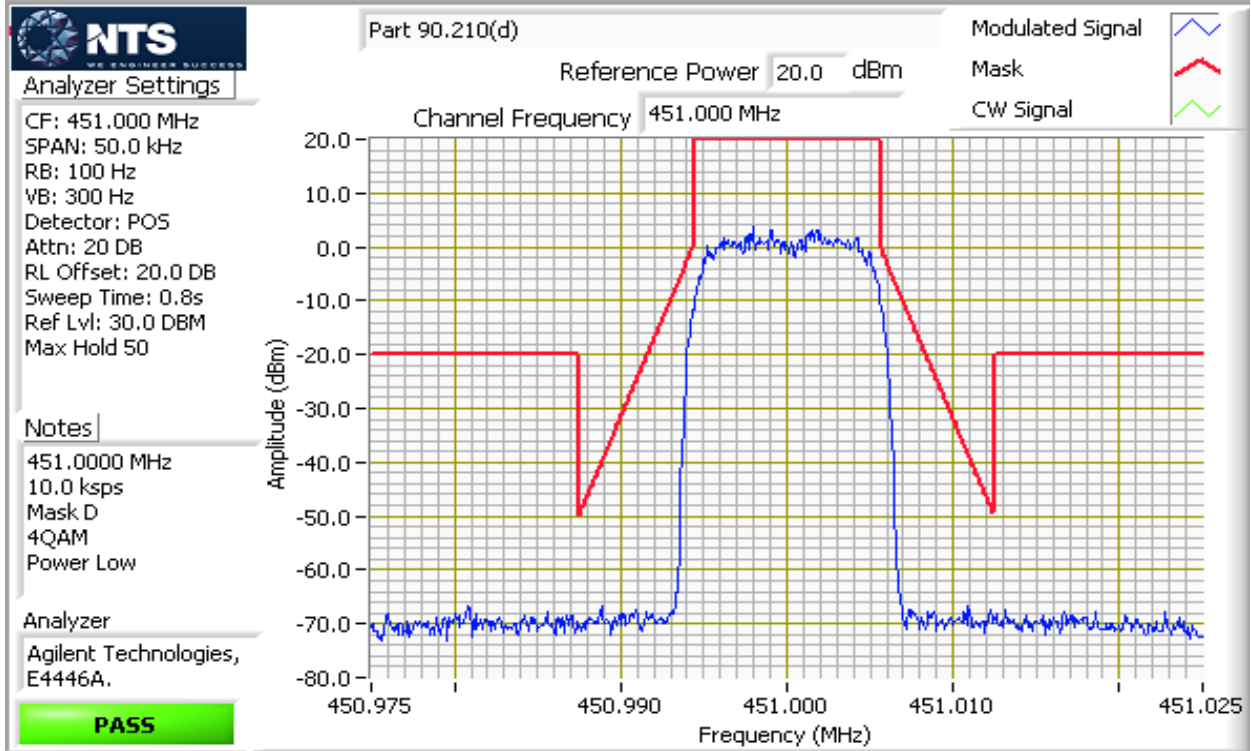

Client: GE MDS LLC	Job Number: J97704
Model: LN400	T-Log Number: T97706
Contact: Dennis McCarthy	Project Manager: Christine Krebill
Standard: FCC Part 15, FCC Part 90, EN 300 113-2	Project Coordinator: -
	Class: A

16 kspss: 25 kHz BW (Mask C)

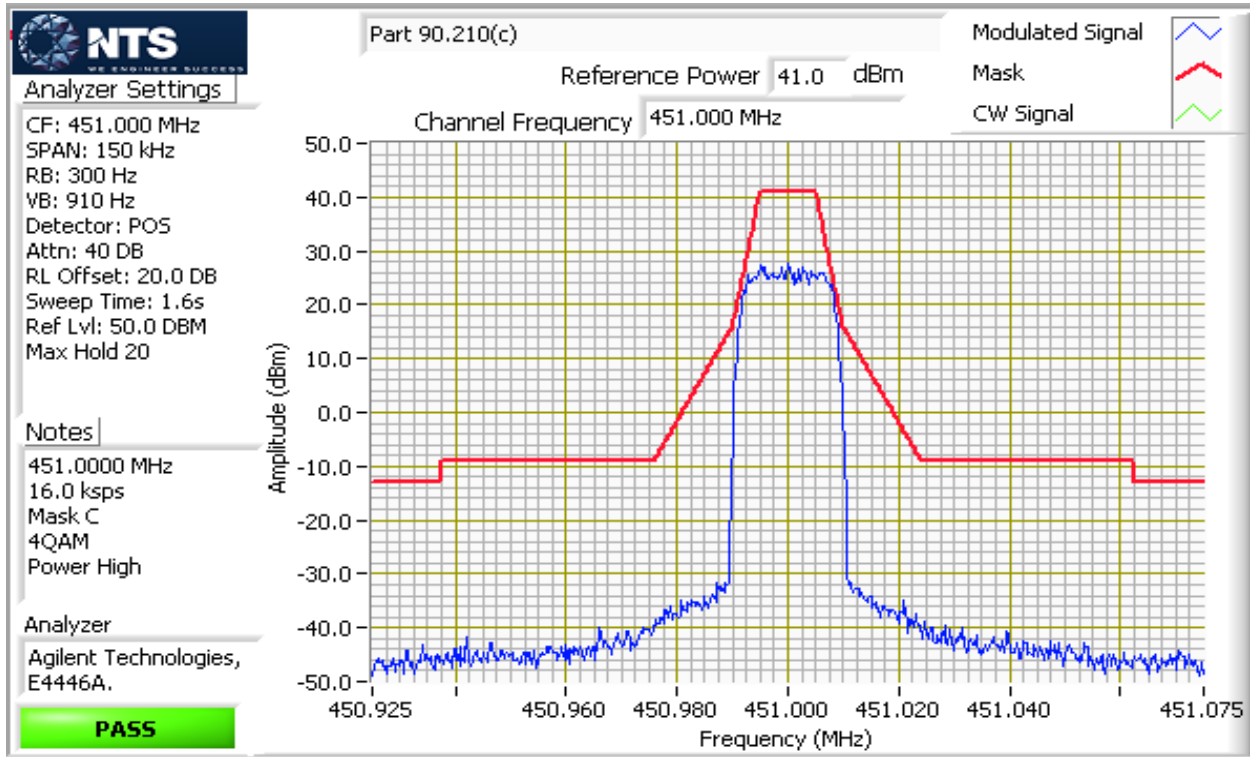



EMC Test Data

Client: GE MDS LLC	Job Number: J97704
Model: LN400	T-Log Number: T97706
Contact: Dennis McCarthy	Project Manager: Christine Krebill
Standard: FCC Part 15, FCC Part 90, EN 300 113-2	Project Coordinator: -
	Class: A

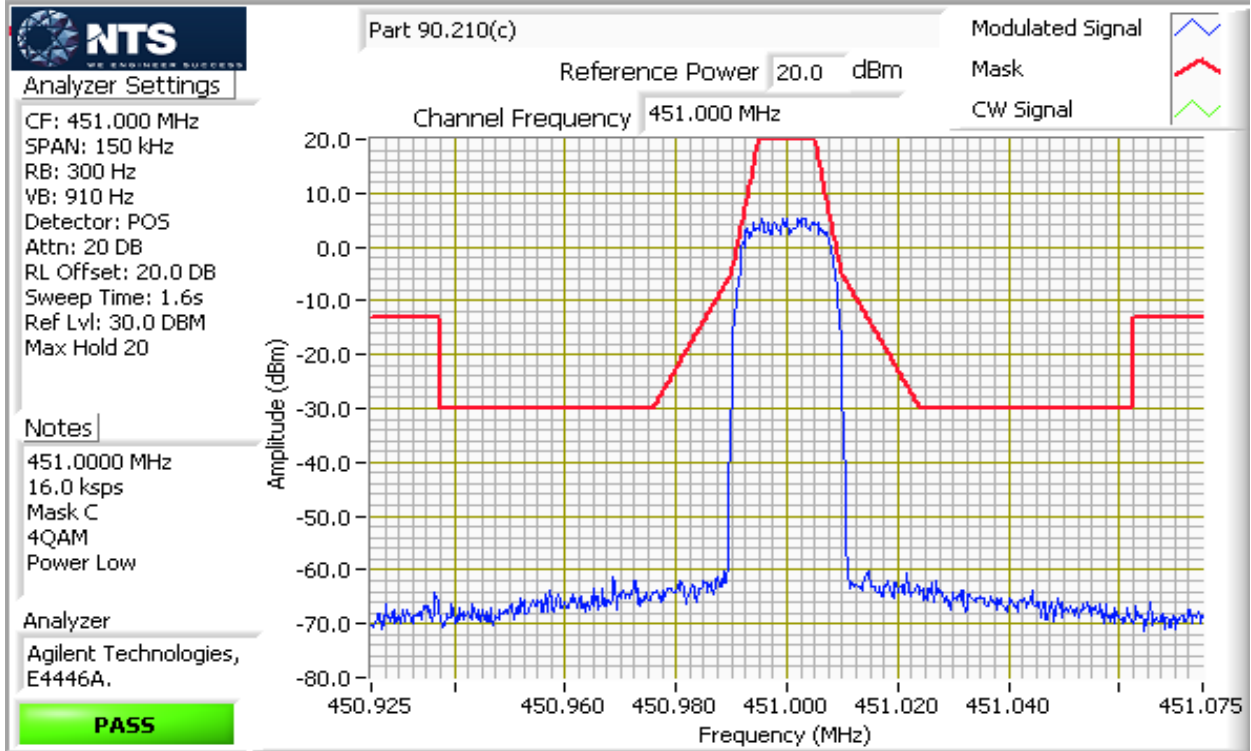

Client: GE MDS LLC	Job Number: J97704
Model: LN400	T-Log Number: T97706
Contact: Dennis McCarthy	Project Manager: Christine Krebill
Standard: FCC Part 15, FCC Part 90, EN 300 113-2	Project Coordinator: -
	Class: A

RSS-119 20 ksps: >20 kHz BW (Mask Y)

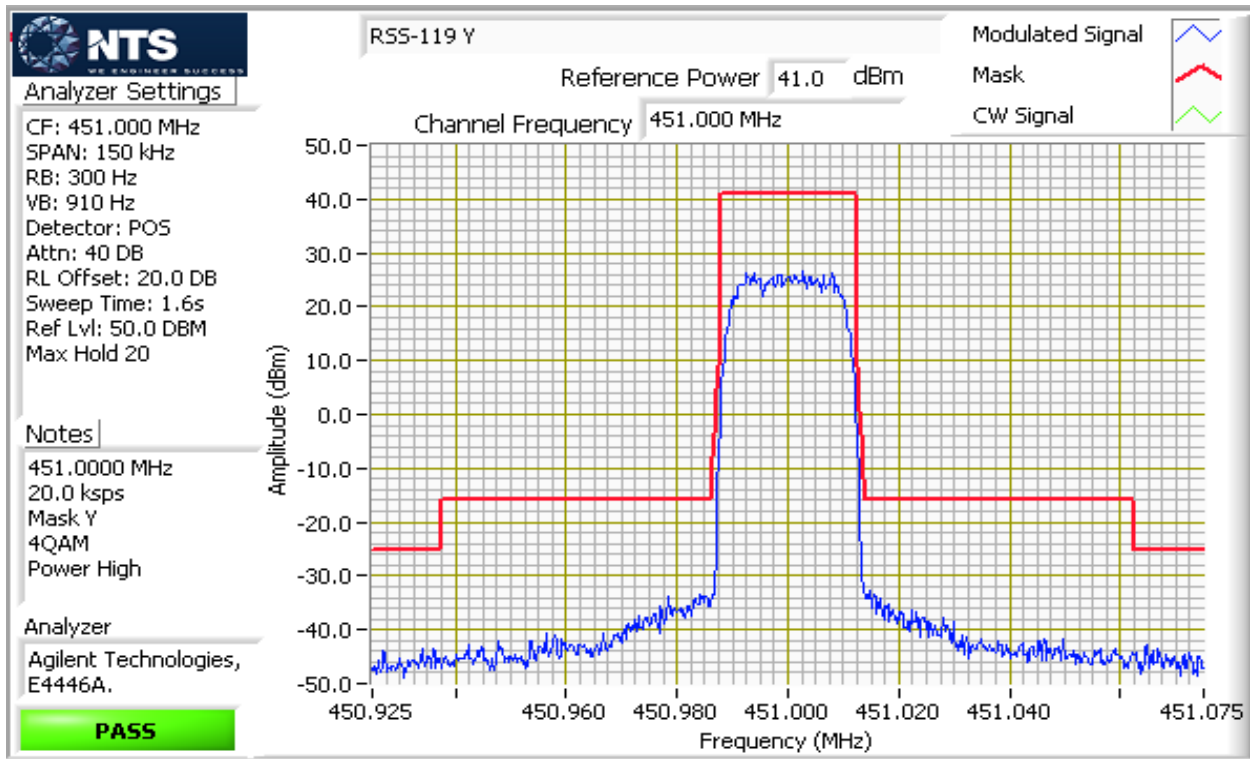

Client: GE MDS LLC	Job Number: J97704
Model: LN400	T-Log Number: T97706
	Project Manager: Christine Krebill
Contact: Dennis McCarthy	Project Coordinator: -
Standard: FCC Part 15, FCC Part 90, EN 300 113-2	Class: A

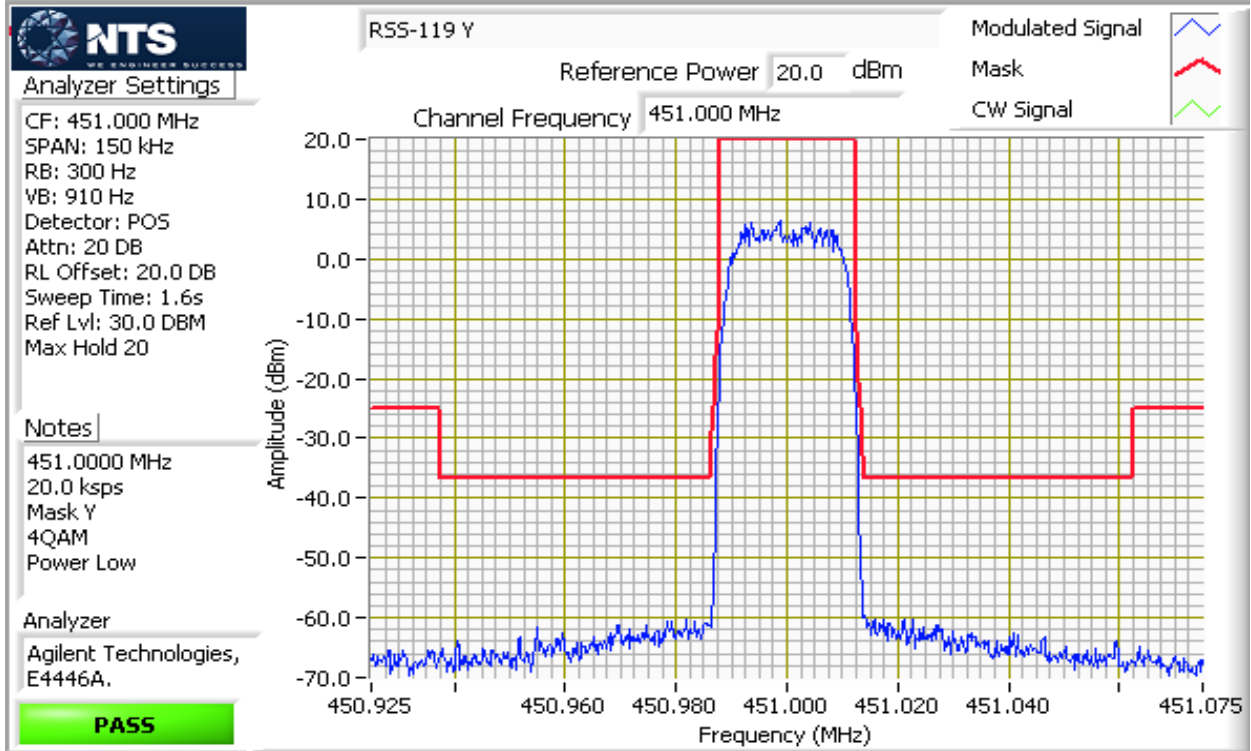



EMC Test Data

Client: GE MDS LLC	Job Number: J97704
Model: LN400	T-Log Number: T97706
	Project Manager: Christine Krebill
Contact: Dennis McCarthy	Project Coordinator: -
Standard: FCC Part 15, FCC Part 90, EN 300 113-2	Class: A

FCC part 90.221 ACP for 22 kHz Occupied Bandwidth operations

Date of Test: 28-Apr-15
 Test Engineer: Deniz Demirci
 Test Location: FT Lab #4

Config. Used: 1
 Config Change: none
 EUT Voltage: 13.8 VDC

Carrier frequency: 451.0000 MHz 20.0 ksps, 4QAM

Frequency offset	Adjacent channel frequency (MHz)	Measured adjacent channel power			Limit (dBc)	Margin (dBm)	Result
		Adj. power (dBm) ¹	Tx power (dBm)	Adj. power (dBc)			
High power							
-25 kHz	450.9750	-23.8	41.0	-64.7	-60.0	-4.7	Pass
+25 kHz	451.0250	-23.5	41.0	-64.4	-60.0	-4.4	Pass
-50 kHz	450.9500	-30.2	40.9	-71.1	-70.0	-1.1	Pass
+50 kHz	451.0500	-29.5	40.9	-70.4	-70.0	-0.4	Pass
-75 kHz	450.9250	-31.9	41.0	-72.9	-70.0	-2.9	Pass
+75 kHz	451.0750	-32.1	41.0	-73.1	-70.0	-3.1	Pass
Low power							
-25 kHz	450.9750	-50.4	19.0	-69.4	-55.0	-14.4	Pass
+25 kHz	451.0250	-50.9	19.0	-69.9	-55.0	-14.9	Pass
-50 kHz	450.9500	-52.8	19.1	-71.9	-70.0	-1.9	Pass
+50 kHz	451.0500	-52.5	19.1	-71.6	-70.0	-1.6	Pass
-75 kHz	450.9250	-54.4	19.3	-73.7	-70.0	-3.7	Pass
+75 kHz	451.0750	-54.3	19.3	-73.6	-70.0	-3.6	Pass

Note 1:	Adjacent channel power measured using a spectrum analyzer (see plots below) with RBW: 300 Hz, VB: 910 Hz, peak detector. Adjacent channel Integrated power calculated over 18 kHz measurement bandwidth.
Note 2:	4QAM modulation has the worst case spectral mask results hence 4QAM was used for adjacent channel power measurements.
Note 3:	Measurements were performed with peak detector but the title of result table in the spectrum analyzer indicates "RMS Results" which is not the case. The results are peak power. (See carrier power as a reference)



EMC Test Data

Client: GE MDS LLC	Job Number: J97704
Model: LN400	T-Log Number: T97706
	Project Manager: Christine Krebill
Contact: Dennis McCarthy	Project Coordinator: -
Standard: FCC Part 15, FCC Part 90, EN 300 113-2	Class: A

High power, 25 kHz frequency offset

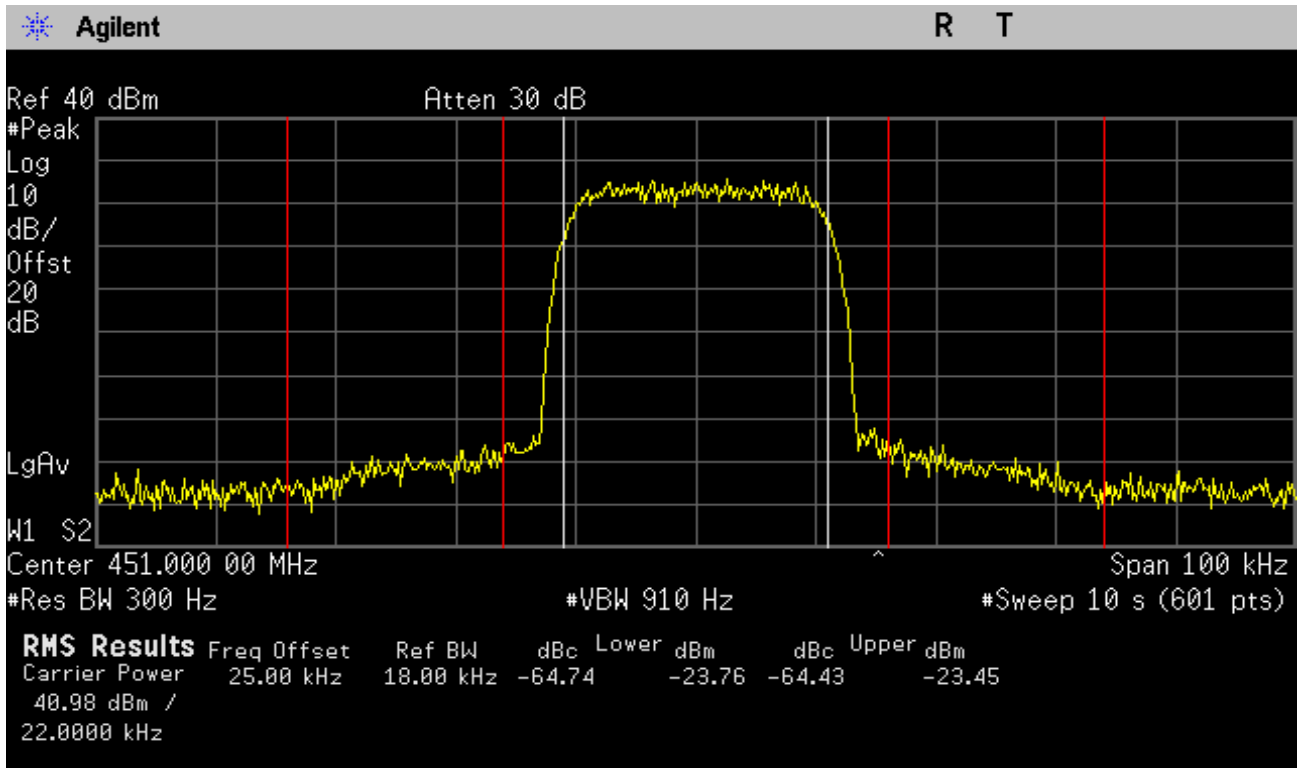



EMC Test Data

Client: GE MDS LLC	Job Number: J97704
Model: LN400	T-Log Number: T97706
	Project Manager: Christine Krebill
Contact: Dennis McCarthy	Project Coordinator: -
Standard: FCC Part 15, FCC Part 90, EN 300 113-2	Class: A

High power, 50 kHz frequency offset

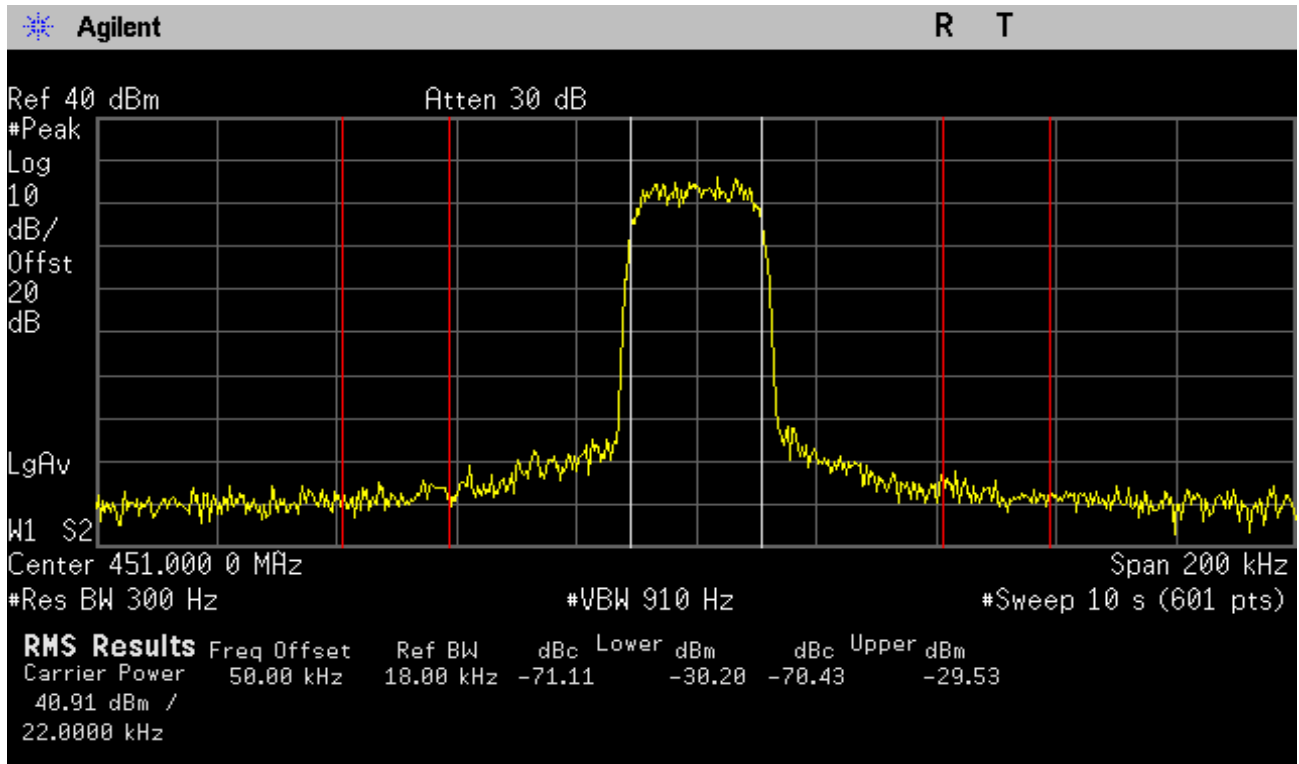



EMC Test Data

Client: GE MDS LLC	Job Number: J97704
Model: LN400	T-Log Number: T97706
	Project Manager: Christine Krebill
Contact: Dennis McCarthy	Project Coordinator: -
Standard: FCC Part 15, FCC Part 90, EN 300 113-2	Class: A

High power, 75 kHz frequency offset

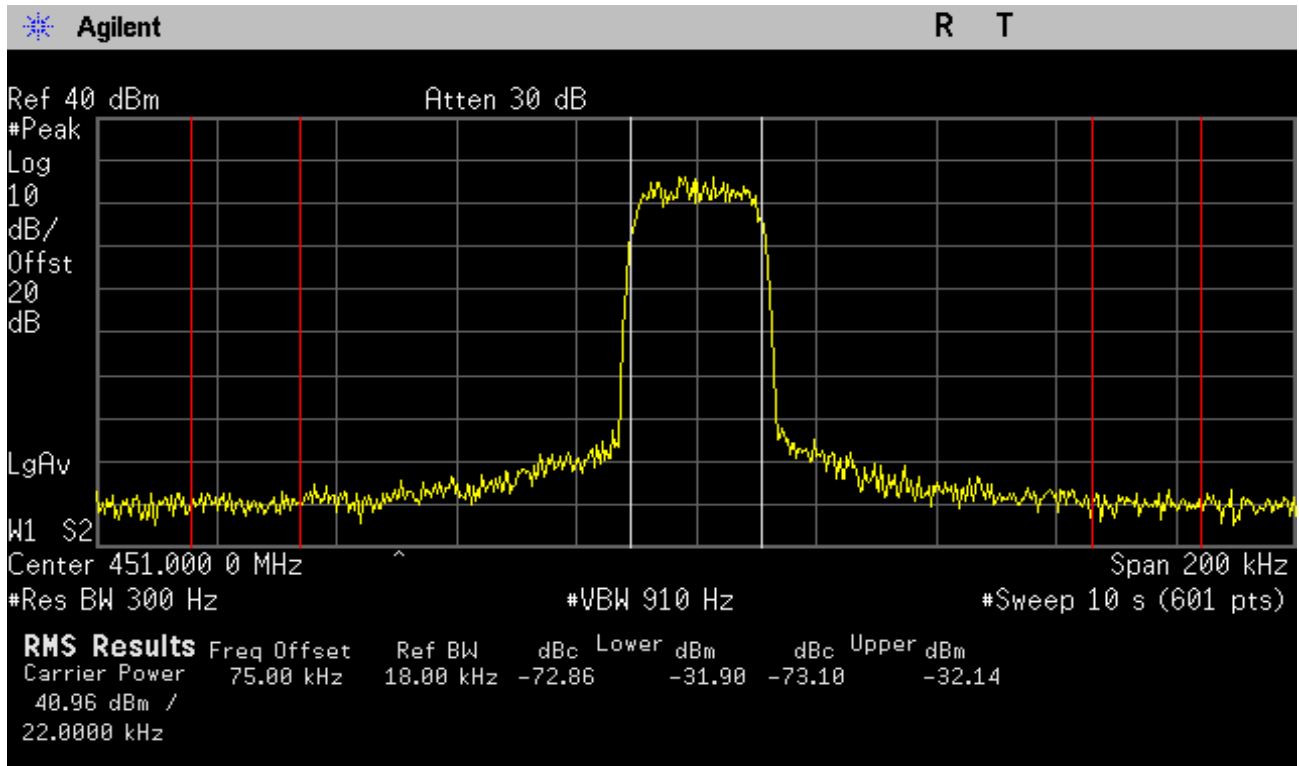



EMC Test Data

Client: GE MDS LLC	Job Number: J97704
Model: LN400	T-Log Number: T97706
	Project Manager: Christine Krebill
Contact: Dennis McCarthy	Project Coordinator: -
Standard: FCC Part 15, FCC Part 90, EN 300 113-2	Class: A

Low power, 25 kHz frequency offset

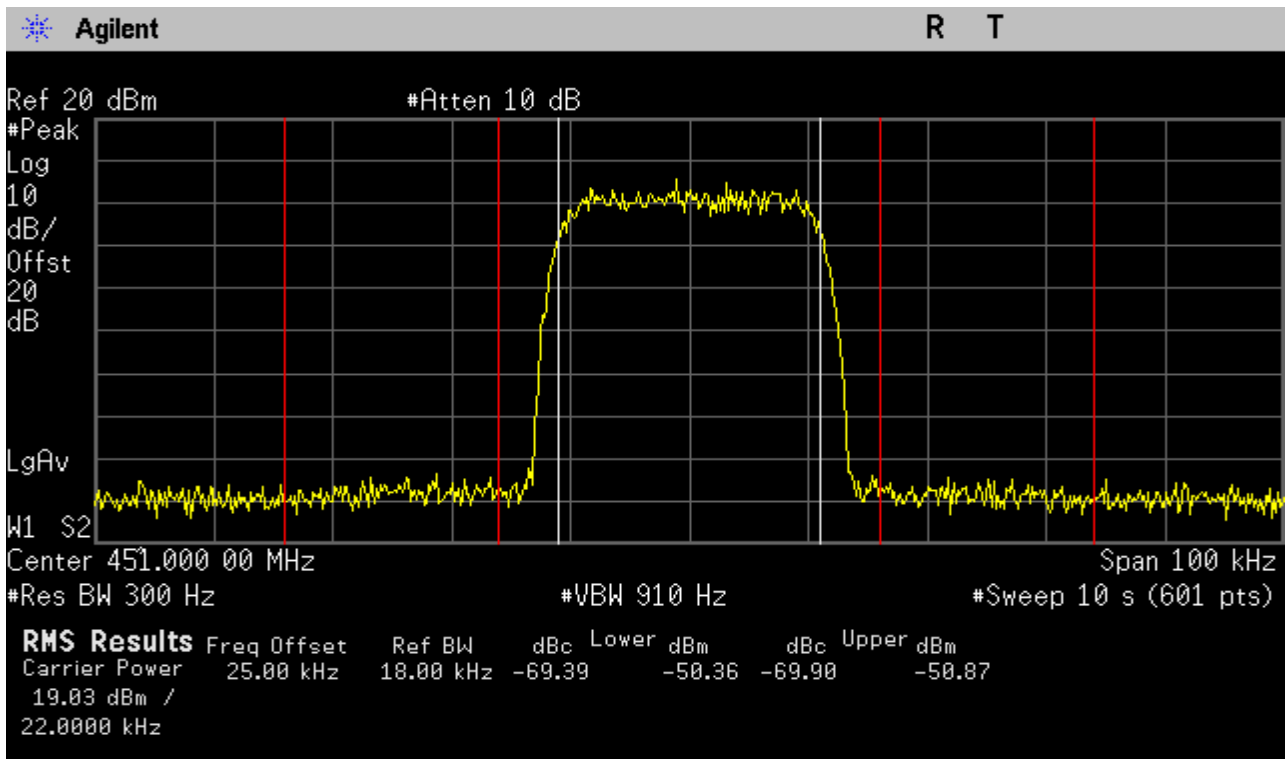



EMC Test Data

Client: GE MDS LLC	Job Number: J97704
Model: LN400	T-Log Number: T97706
	Project Manager: Christine Krebill
Contact: Dennis McCarthy	Project Coordinator: -
Standard: FCC Part 15, FCC Part 90, EN 300 113-2	Class: A

Low power, 50 kHz frequency offset

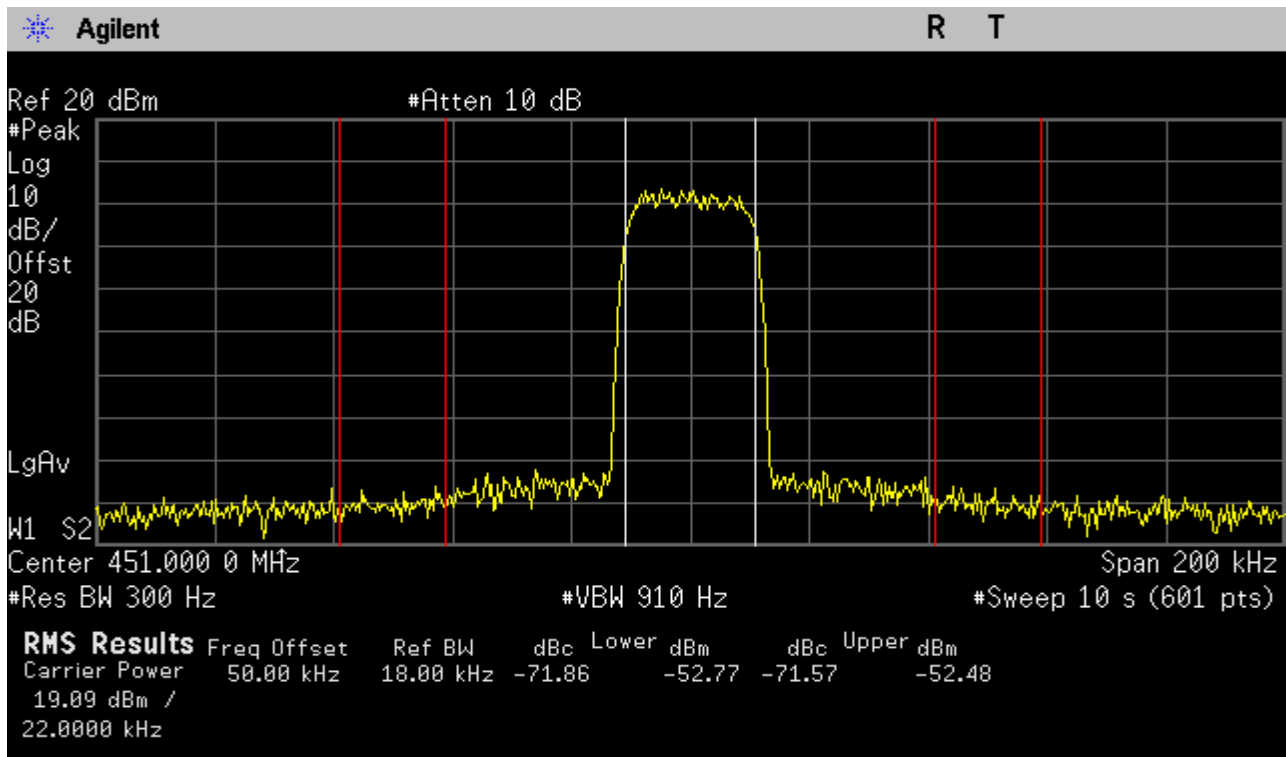



EMC Test Data

Client: GE MDS LLC	Job Number: J97704
Model: LN400	T-Log Number: T97706
	Project Manager: Christine Krebill
Contact: Dennis McCarthy	Project Coordinator: -
Standard: FCC Part 15, FCC Part 90, EN 300 113-2	Class: A

Low power, 75 kHz frequency offset

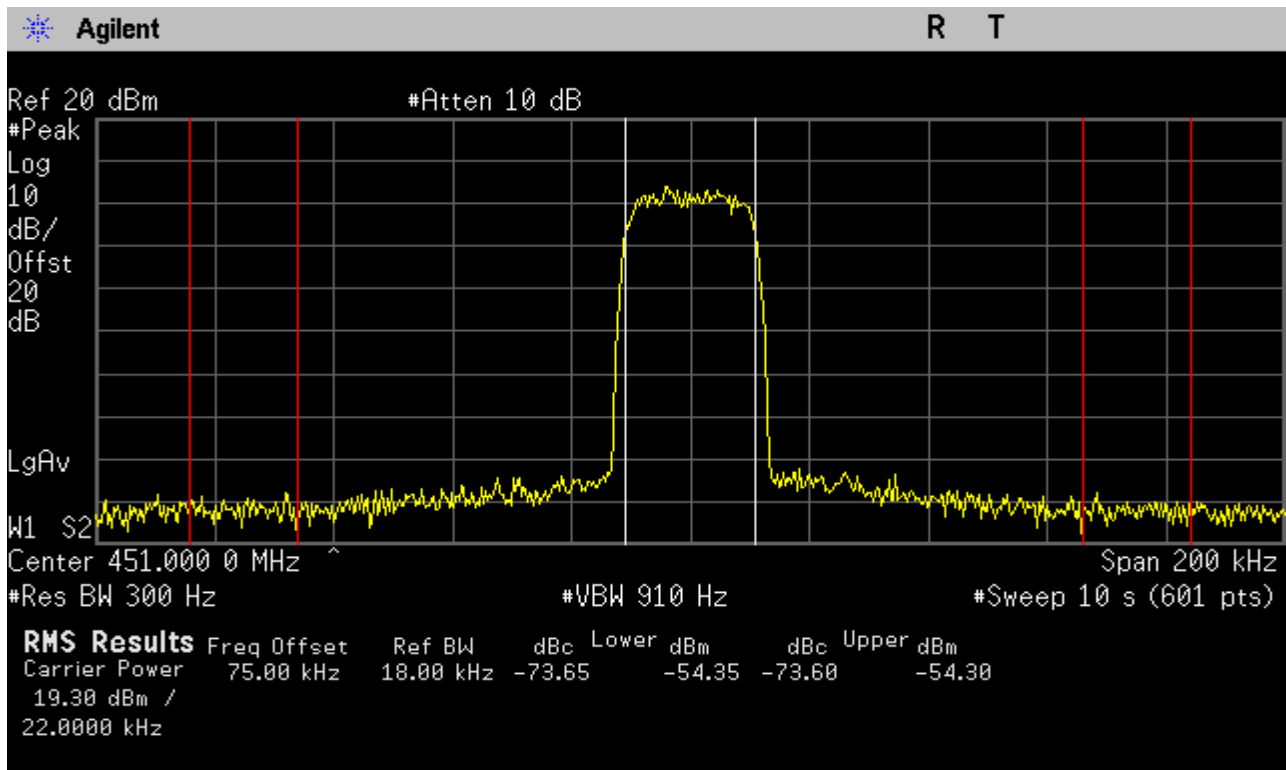



EMC Test Data

Client: GE MDS LLC	Job Number: J97704
Model: LN400	T-Log Number: T97706
	Project Manager: Christine Krebill
Contact: Dennis McCarthy	Project Coordinator: -
Standard: FCC Part 15, FCC Part 90, EN 300 113-2	Class: A

Run #3: Signal Bandwidth

Date of Test: 28-Apr-15
 Test Engineer: Deniz Demirci
 Test Location: FT Lab #4
 Config. Used: 1
 Config Change: none
 EUT Voltage: 13.8 VDC

Power Setting	Baud rate (ksps)	Frequency (MHz)	RBW (kHz)	OBW (kHz)	
				26dB	99%
41	4.8	451.0000	0.1		5.16
41	9.6	451.0000	0.2		10.3
41	10.0	451.0000	0.2		10.8
41	16.0	451.0000	0.2		17.2
41	20.0	451.0000	0.3		21.4

- Note 1: 99% bandwidth measured in accordance with RSS GEN, with RB 1% to 5% of the occupied BW and VB > 3xRB
- Note 2: 4.8 ksps baud rate was measured with both 4QAM and 64QAM modulations and both OBW results are the same. Modulation type does not have significant effect to measured power bandwidth.

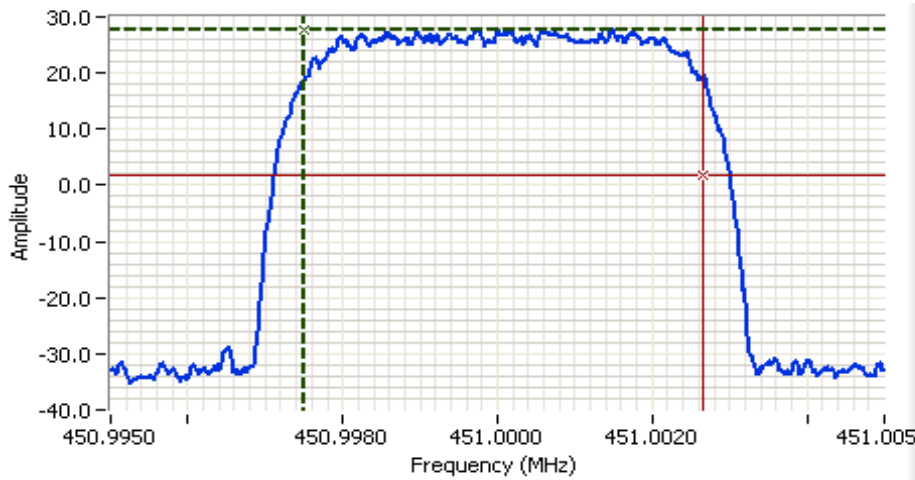

Analyzer Settings

Agilent Technologies, E4446A
 CF: 451.000 MHz
 SPAN: 10.0 kHz
 RB: 100 Hz
 VB: 300 Hz
 Detector: POS
 Attn: 70 DB
 RL Offset: 20.0 DB
 Sweep Time: 111.3ms
 Ref Lvl: 50.0 DBM

Comments

99% BW: 5.16 kHz
 4QAM
 4.8 ksps

Cursor 1 450.9975 27.8
 Cursor 2 451.0027 1.8
 Delta Freq. 5.16 kHz
 Delta Amplitude 26.0



Client: GE MDS LLC	Job Number: J97704
Model: LN400	T-Log Number: T97706
Contact: Dennis McCarthy	Project Manager: Christine Krebill
Standard: FCC Part 15, FCC Part 90, EN 300 113-2	Project Coordinator: -
	Class: A

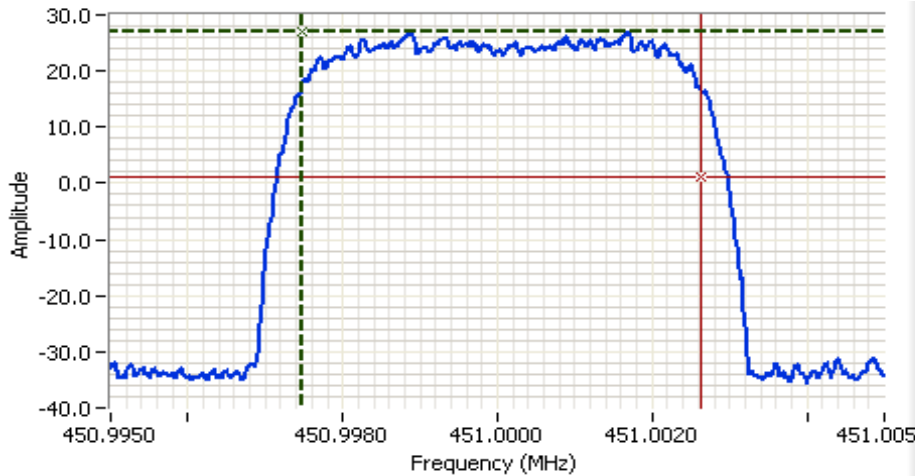

Analyzer Settings
 Agilent Technologies, E4446A
 CF: 451.000 MHz
 SPAN: 10.0 kHz
 RB: 100 Hz
 VB: 300 Hz
 Detector: POS
 Attn: 70 DB
 RL Offset: 20.0 DB
 Sweep Time: 111.3ms
 Ref Lvl: 50.0 DBM

Comments
 99% BW: 5.16 kHz
 64QAM
 4.8 ksps

Cursor 1 450.9975 27.0

Cursor 2 451.0026 1.0

Delta Freq. 5.16 kHz

Delta Amplitude 26.0

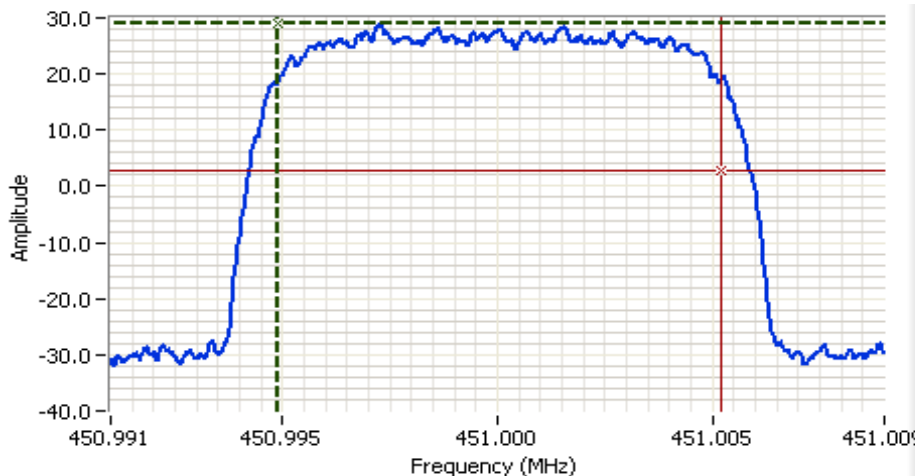

Analyzer Settings
 Agilent Technologies, E4446A
 CF: 451.000 MHz
 SPAN: 18.0 kHz
 RB: 200 Hz
 VB: 620 Hz
 Detector: POS
 Attn: 70 DB
 RL Offset: 20.0 DB
 Sweep Time: 252.8ms
 Ref Lvl: 50.0 DBM

Comments
 99% BW: 10.3 kHz
 4QAM
 9.6 ksps

Cursor 1 450.9949 28.9

Cursor 2 451.0052 2.9

Delta Freq. 10.3 kHz

Delta Amplitude 26.0



Client: GE MDS LLC	Job Number: J97704
Model: LN400	T-Log Number: T97706
Contact: Dennis McCarthy	Project Manager: Christine Krebill
Standard: FCC Part 15, FCC Part 90, EN 300 113-2	Project Coordinator: -
	Class: A

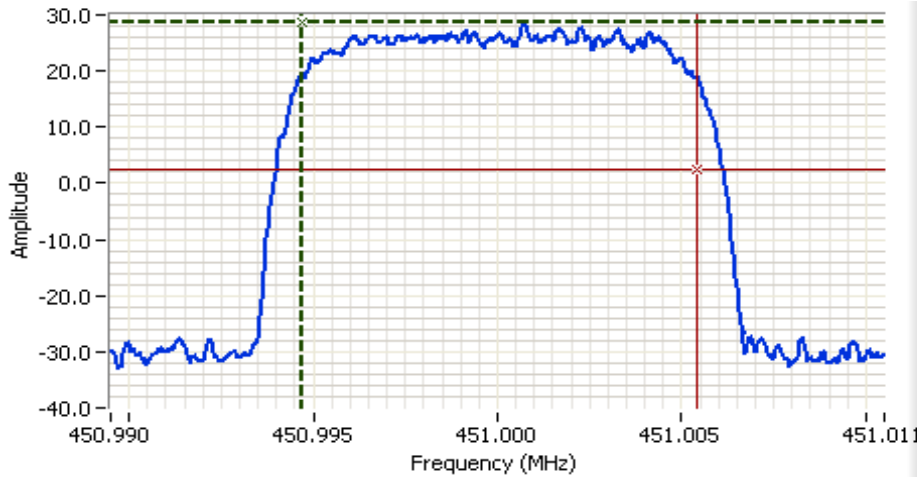

Analyzer Settings
 Agilent Technologies, E4446A
 CF: 451.000 MHz
 SPAN: 21.0 kHz
 RB: 200 Hz
 VB: 620 Hz
 Detector: POS
 Attn: 70 DB
 RL Offset: 20.0 DB
 Sweep Time: 0.3s
 Ref Lvl: 50.0 DBM

Comments
 99% BW: 10.8 kHz
 4QAM
 10.0 kpsps

Cursor 1 450.9947 28.5
 Cursor 2 451.0054 2.5

Delta Freq. 10.8 kHz
 Delta Amplitude 26.0

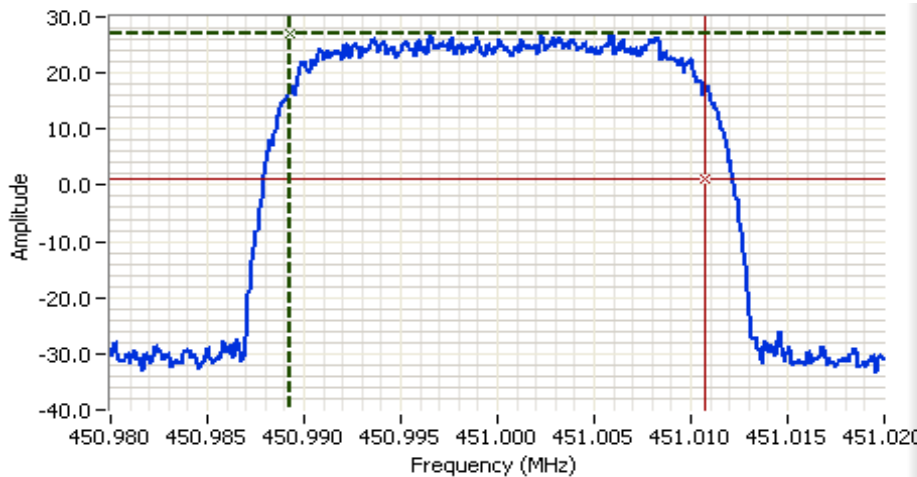

Analyzer Settings
 Agilent Technologies, E4446A
 CF: 451.000 MHz
 SPAN: 40.0 kHz
 RB: 300 Hz
 VB: 910 Hz
 Detector: POS
 Attn: 70 DB
 RL Offset: 20.0 DB
 Sweep Time: 0.4s
 Ref Lvl: 50.0 DBM

Comments
 99% BW: 21.4 kHz
 4QAM
 20.0 kpsps

Cursor 1 450.9893 27.0
 Cursor 2 451.0107 1.0

Delta Freq. 21.4 kHz
 Delta Amplitude 26.0





EMC Test Data

Client: GE MDS LLC	Job Number: J97704
Model: LN400	T-Log Number: T97706
	Project Manager: Christine Krebill
Contact: Dennis McCarthy	Project Coordinator: -
Standard: FCC Part 15, FCC Part 90, EN 300 113-2	Class: A

Run #4: Out of Band Spurious Emissions, Conducted

Date of Test: 28-Apr-15
 Test Engineer: Deniz Demirci
 Test Location: FT Lab #4

Config. Used: 1
 Config Change: none
 EUT Voltage: 13.8 VDC

Frequency MHz	Level dBm	Port	FCC Part 90.210		Detector Pk/QP/Avg	Comments	Channel
			Limit	Margin			
406.102	39.9	RF Port	-	-	Peak	Carrier power	406.1 MHz
303.501	-29.6	RF Port	-25.0	-4.6	Peak		406.1 MHz
296.579	-29.0	RF Port	-25.0	-4.0	Peak		418.0 MHz
417.973	39.9	RF Port	-	-	Peak	Carrier power	418.0 MHz
303.034	-26.4	RF Port	-25.0	-1.4	Peak		418.0 MHz
430.010	40.2	RF Port	-	-	Peak	Carrier power	430.0 MHz
305.368	-25.7	RF Port	-25.0	-0.7	Peak		430.0 MHz
451.017	40.1	RF Port	-	-	Peak	Carrier power	451.0 MHz
351.117	-27.4	RF Port	-25.0	-2.4	Peak		451.0 MHz
327.543	-27.5	RF Port	-25.0	-2.5	Peak		451.0 MHz
359.987	-27.7	RF Port	-25.0	-2.7	Peak		460.0 MHz
343.181	-28.0	RF Port	-25.0	-3.0	Peak		460.0 MHz
459.987	39.2	RF Port	-	-	Peak	Carrier power	460.0 MHz
300.000	-28.6	RF Port	-25.0	-3.6	Peak		470.0 MHz
348.550	-27.7	RF Port	-25.0	-2.7	Peak		470.0 MHz
469.993	39.3	RF Port	-	-	Peak	Carrier power	470.0 MHz

Note 1:	The spectrum analyzer settings for out-of-band spurious emissions; RBW: 100 kHz, VBW: 300 kHz for frequencies below 1 GHz, RBW: 1 MHz, VBW: 3 MHz for frequencies above 1 GHz.
Note 2:	A high pass filter used above 1 GHz measurements.
Note 3:	Transmitter set to 6.25 kHz BW mode as a worst case which has the lowest BW and highest power spectral density.
Note 4:	The limit is taken from FCC Part 90.210 Mask E (RSS-119 Mask E)

Client: GE MDS LLC	Job Number: J97704
Model: LN400	T-Log Number: T97706
Contact: Dennis McCarthy	Project Manager: Christine Krebill
Standard: FCC Part 15, FCC Part 90, EN 300 113-2	Project Coordinator: -
	Class: A

Plot for low channel, power setting: High

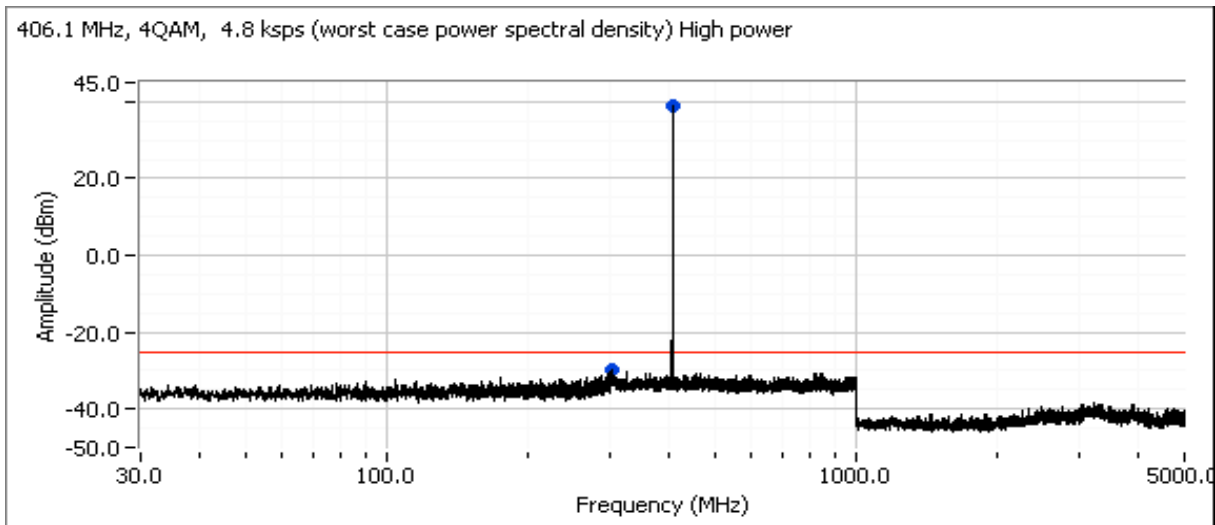

Plot for center channel, power setting: High

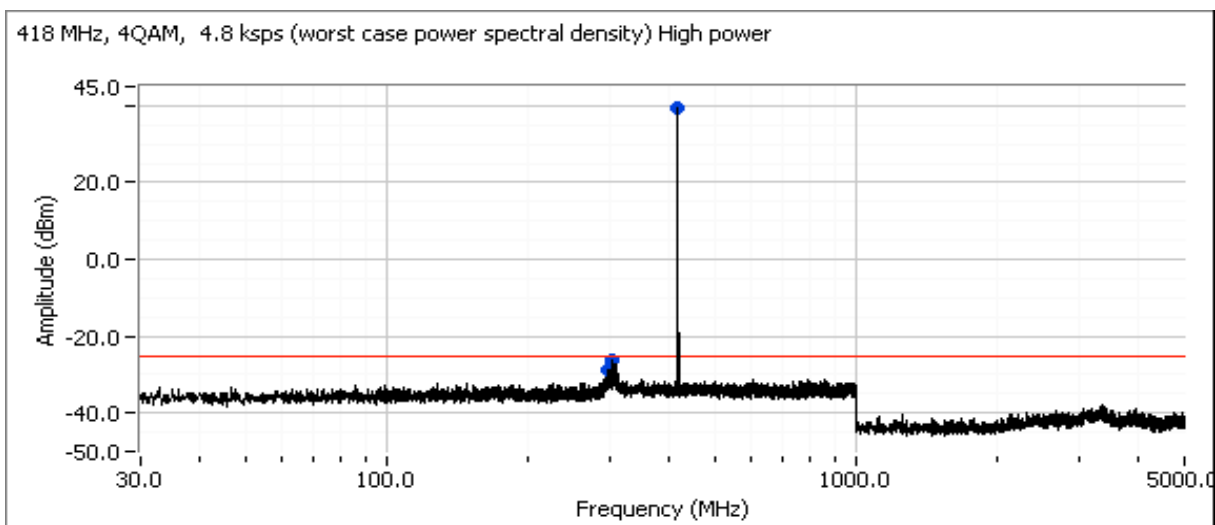

Client: GE MDS LLC	Job Number: J97704
Model: LN400	T-Log Number: T97706
	Project Manager: Christine Krebill
Contact: Dennis McCarthy	Project Coordinator: -
Standard: FCC Part 15, FCC Part 90, EN 300 113-2	Class: A

Plot for high channel, power setting: High

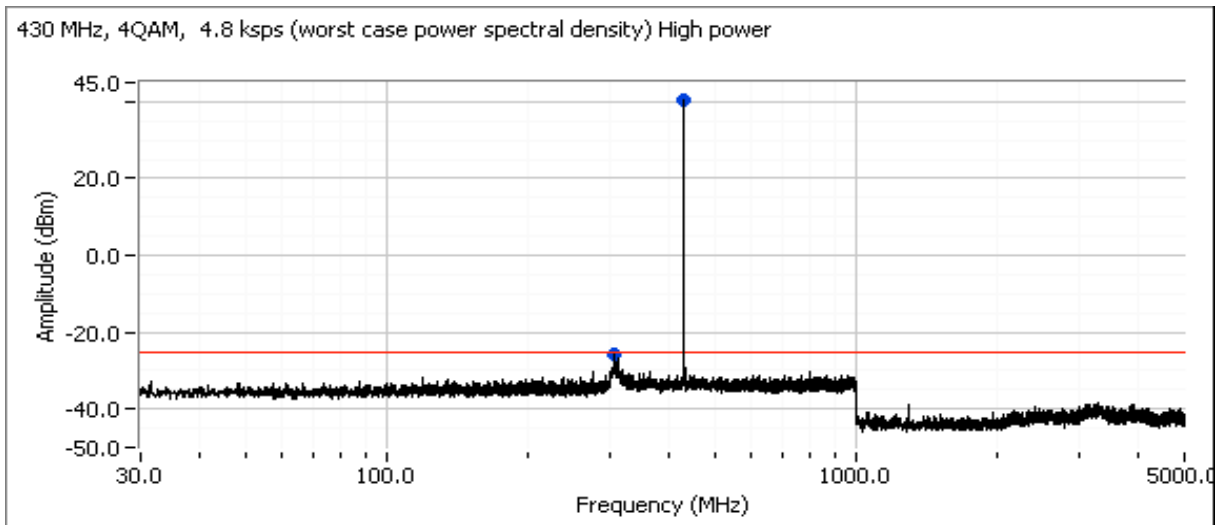

Plot for low channel, power setting: High

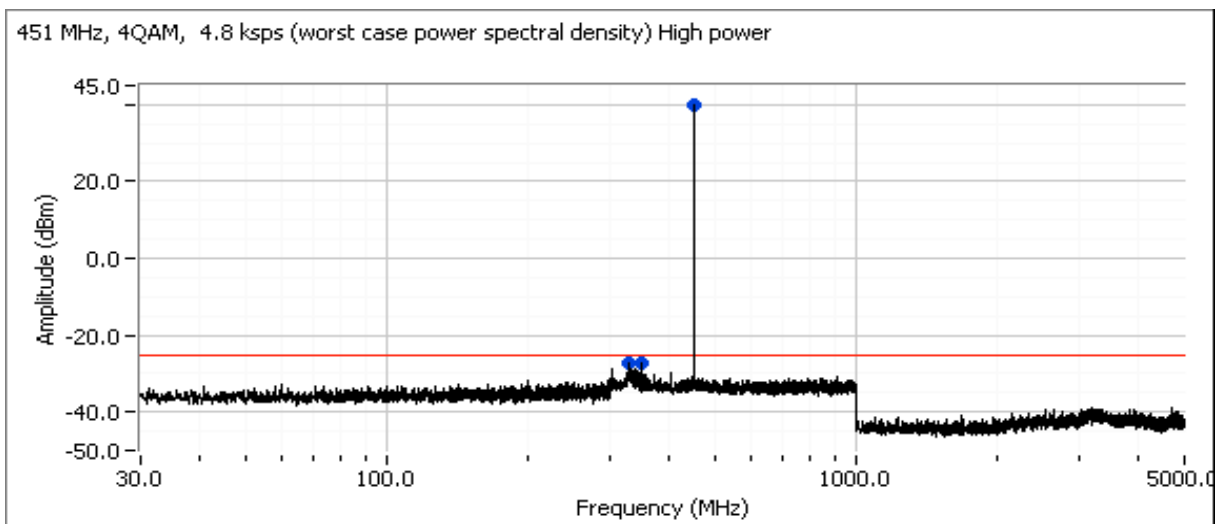

Client: GE MDS LLC	Job Number: J97704
Model: LN400	T-Log Number: T97706
	Project Manager: Christine Krebill
Contact: Dennis McCarthy	Project Coordinator: -
Standard: FCC Part 15, FCC Part 90, EN 300 113-2	Class: A

Plot for center channel, power setting: High

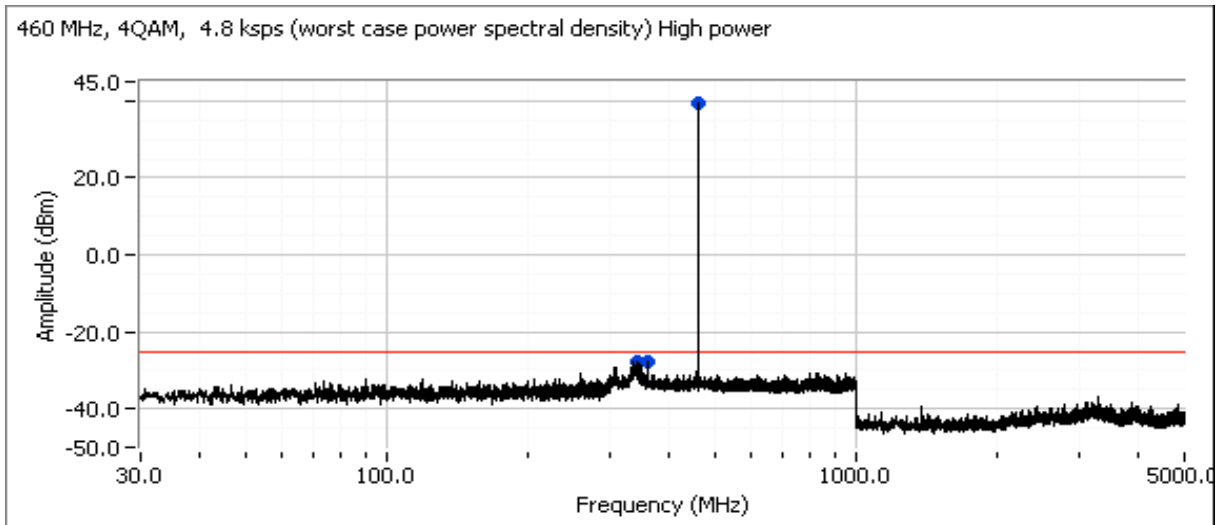

Plot for high channel, power setting: High

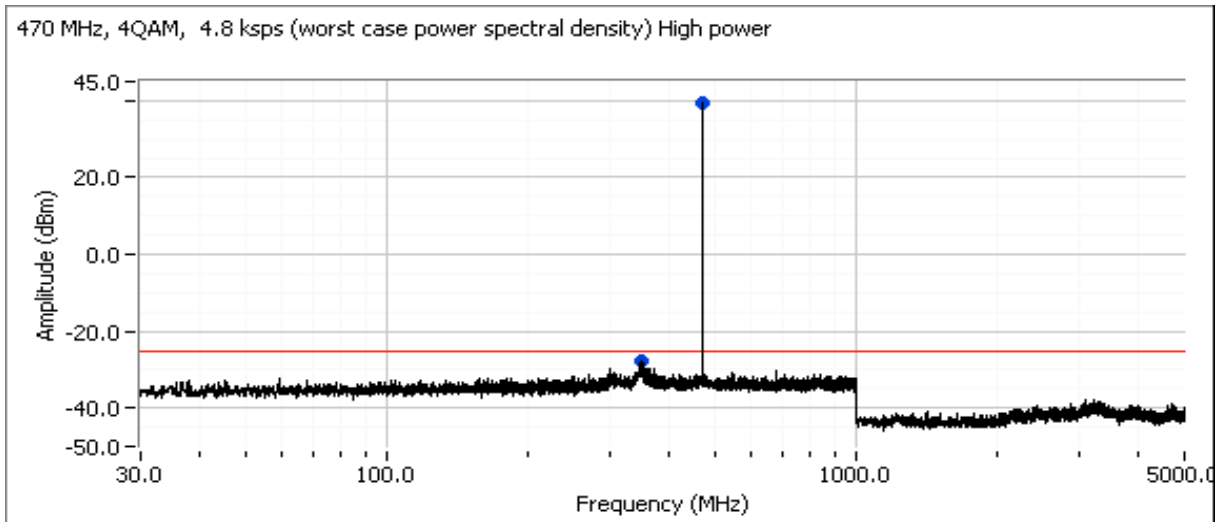



EMC Test Data

Client: GE MDS LLC	Job Number: J97704
Model: LN400	T-Log Number: T97706
	Project Manager: Christine Krebill
Contact: Dennis McCarthy	Project Coordinator: -
Standard: FCC Part 15, FCC Part 90, EN 300 113-2	Class: A

Run #5: Out of Band Spurious Emissions, Radiated

Conducted limit (dBm): -25
 Approximate field strength limit @ 3m: 70.2

Date of Test: 4/28/2015; 4/30/2015
 Test Engineer: Deniz Demirci; M. Birgani
 Test Location: FT Ch #3

Config. Used: 1
 Config Change: none
 EUT Voltage: 13.8 Vdc and 5 Vdc

Run #5b: - Preliminary EUT Field Strength Measurements

Frequency	Level	Pol	FCC Part 90		Detector	Azimuth	Height	Comments	Channel
MHz	dB μ V/m	v/h	Limit	Margin	Pk/QP/Avg	degrees	meters		
812.203	46.7	V	72.4	-25.7	PK	232	1.0		406.1 MHz
406.093	84.2	V	-	-	PK	131	2.5	Fundamental	406.1 MHz
499.999	29.6	V	72.4	-42.8	PK	48	1.5		406.1 MHz
51.097	32.5	H	72.4	-39.9	PK	220	1.0		406.1 MHz
1213.330	55.5	H	70.2	-14.7	Peak	276	2.0		406.1 MHz
1620.000	56.3	H	70.2	-13.9	Peak	239	2.5		406.1 MHz
2026.670	53.2	V	70.2	-17.0	Peak	219	1.0		406.1 MHz
3246.670	49.3	V	70.2	-20.9	Peak	180	1.0		406.1 MHz
51.397	32.5	H	72.4	-39.9	Peak	201	1.0		418.0 MHz
418.002	84.5	V	-	-	Peak	145	2.0	Fundamental	418.0 MHz
836.019	46.8	V	72.4	-25.6	Peak	95	2.0		418.0 MHz
1253.330	61.8	V	70.2	-8.4	Peak	33	2.0		418.0 MHz
1666.670	52.9	H	70.2	-17.3	Peak	262	2.0		418.0 MHz
2086.670	53.5	V	70.2	-16.7	Peak	205	1.0		418.0 MHz
3340.000	50.6	H	70.2	-19.6	Peak	178	2.5		418.0 MHz
3760.000	50.9	V	70.2	-19.3	Peak	144	2.0		418.0 MHz
4173.330	52.6	H	70.2	-17.6	Peak	190	1.0		418.0 MHz
859.999	50.7	V	72.4	-21.7	Peak	256	1.5		430.0 MHz
429.992	85.0	V	-	-	Peak	120	2.0	Fundamental	430.0 MHz
1286.670	63.9	H	70.2	-6.3	Peak	72	2.0		430.0 MHz
1720.000	52.7	V	70.2	-17.5	Peak	209	1.0		430.0 MHz
2146.670	51.7	V	70.2	-18.5	Peak	266	1.5		430.0 MHz
3433.330	50.2	V	70.2	-20.0	Peak	85	2.0		430.0 MHz
3866.670	53.7	H	70.2	-16.5	Peak	210	1.0		430.0 MHz



EMC Test Data

Client:	GE MDS LLC	Job Number:	J97704
Model:	LN400	T-Log Number:	T97706
Contact:	Dennis McCarthy	Project Manager:	Christine Krebill
Standard:	FCC Part 15, FCC Part 90, EN 300 113-2	Project Coordinator:	-
		Class:	A

Run #5b: - Preliminary EUT Field Strength Measurements

Frequency MHz	Level dB μ V/m	Pol v/h	FCC Part 90		Detector Pk/QP/Avg	Azimuth degrees	Height meters	Comments	Channel
			Limit	Margin					
450.994	87.3	V	-	-	Peak	126	2.0	Fundamental	451.0 MHz
902.003	48.7	V	72.4	-23.7	Peak	281	2.0		451.0 MHz
1346.670	61.1	V	70.2	-9.1	Peak	32	2.0		451.0 MHz
1800.000	52.3	H	70.2	-17.9	Peak	214	1.0		451.0 MHz
3606.670	50.6	H	70.2	-19.6	Peak	181	1.5		451.0 MHz
4053.330	51.8	V	70.2	-18.4	Peak	280	1.5		451.0 MHz
459.994	85.8	V	-	-	Peak	116	2.0	Fundamental	
920.015	50.6	H	72.4	-21.8	Peak	221	1.0		
1380.000	59.6	V	70.2	-10.6	Peak	19	2.0		460.0 MHz
1840.000	55.1	H	70.2	-15.1	Peak	142	1.0		460.0 MHz
4140.000	51.3	V	70.2	-18.9	Peak	161	1.0		460.0 MHz
469.998	87.4	V	-	-	Peak	121	2.0	Fundamental	470.0 MHz
940.009	59.7	H	72.4	-12.7	Peak	206	1.0		470.0 MHz
1380.000	59.9	V	70.2	-10.3	Peak	44	2.5		470.0 MHz
1840.000	56.1	H	70.2	-14.1	Peak	133	2.0		470.0 MHz
4133.330	52.5	H	70.2	-17.7	Peak	183	2.0		470.0 MHz

Note 1: The field strength limit in the tables above was calculated from the erp/eirp limit detailed in the standard using the free space propagation equation: $E = \sqrt{(30PG)/d}$. This limit is conservative - it does not consider the presence of the ground plane and, for erp limits, the dipole gain (2.2dBi) has not been included. The erp or eirp for all signals with less than 20dB of margin relative to this field strength limit is determined using substitution measurements.

Note 2: Measurements are made with the antenna port terminated.

Note 3: The limit is taken from FCC Part 90.210 Mask E (RSS-119 Mask E)

Client: GE MDS LLC	Job Number: J97704
Model: LN400	T-Log Number: T97706
	Project Manager: Christine Krebill
Contact: Dennis McCarthy	Project Coordinator: -
Standard: FCC Part 15, FCC Part 90, EN 300 113-2	Class: A

Plots for low channel, power setting: High

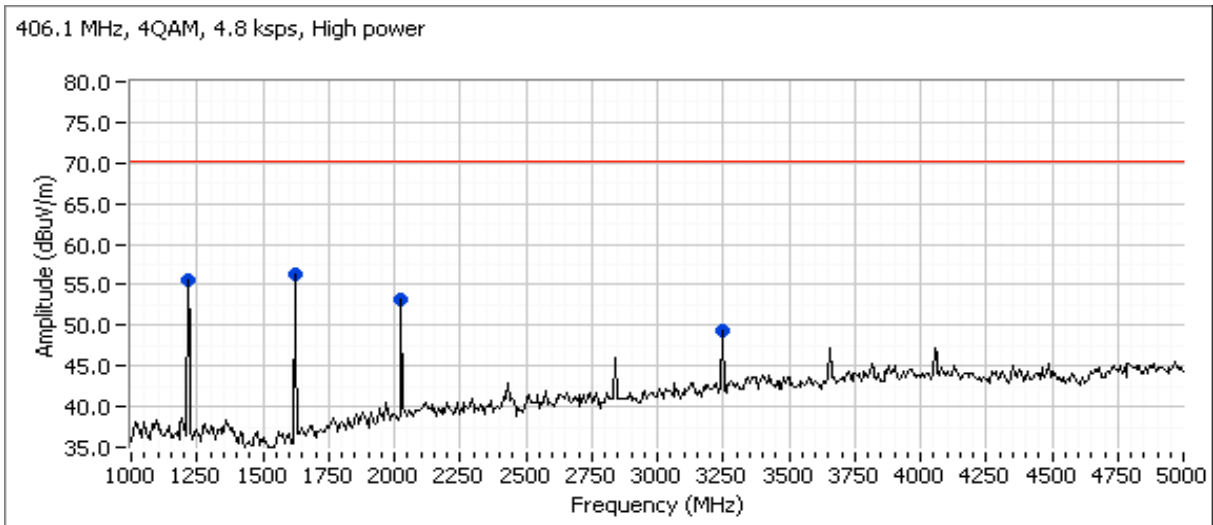
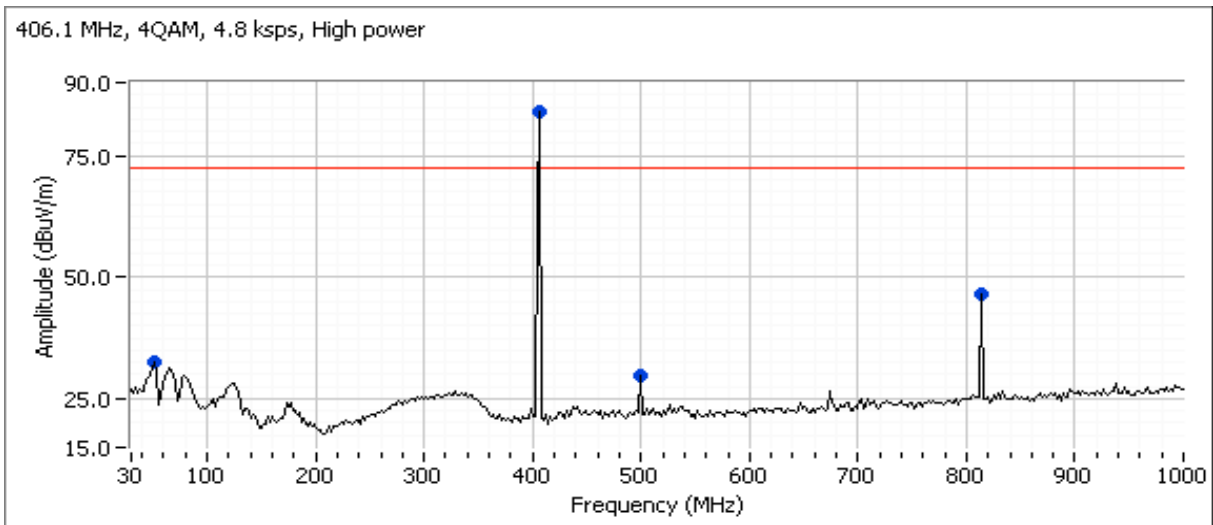

Client:	GE MDS LLC	Job Number:	J97704
Model:	LN400	T-Log Number:	T97706
Contact:	Dennis McCarthy	Project Manager:	Christine Krebill
Standard:	FCC Part 15, FCC Part 90, EN 300 113-2	Project Coordinator:	-
		Class:	A

Plots for center channel, power setting: High

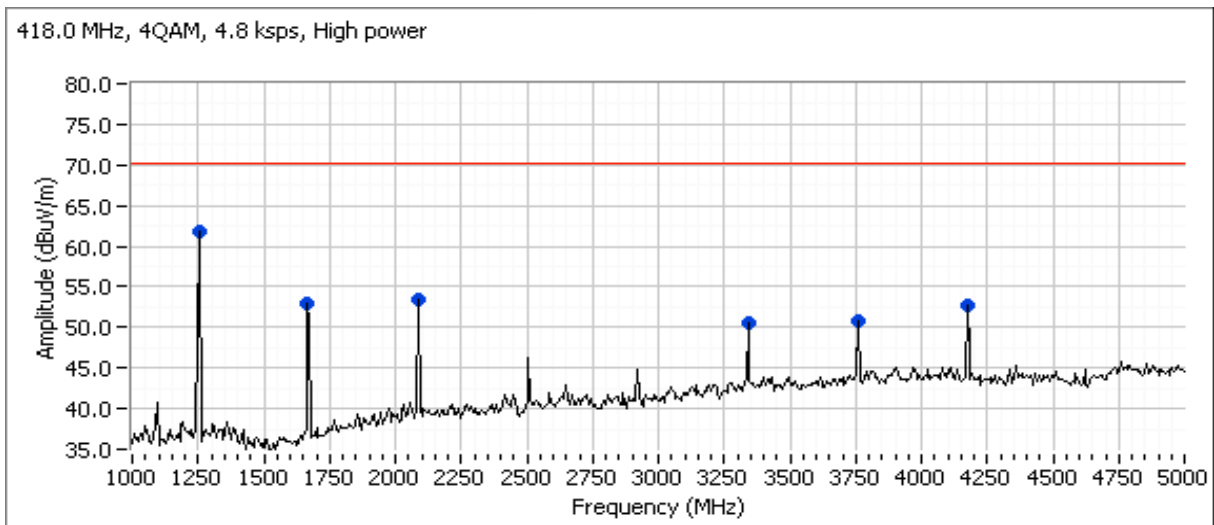
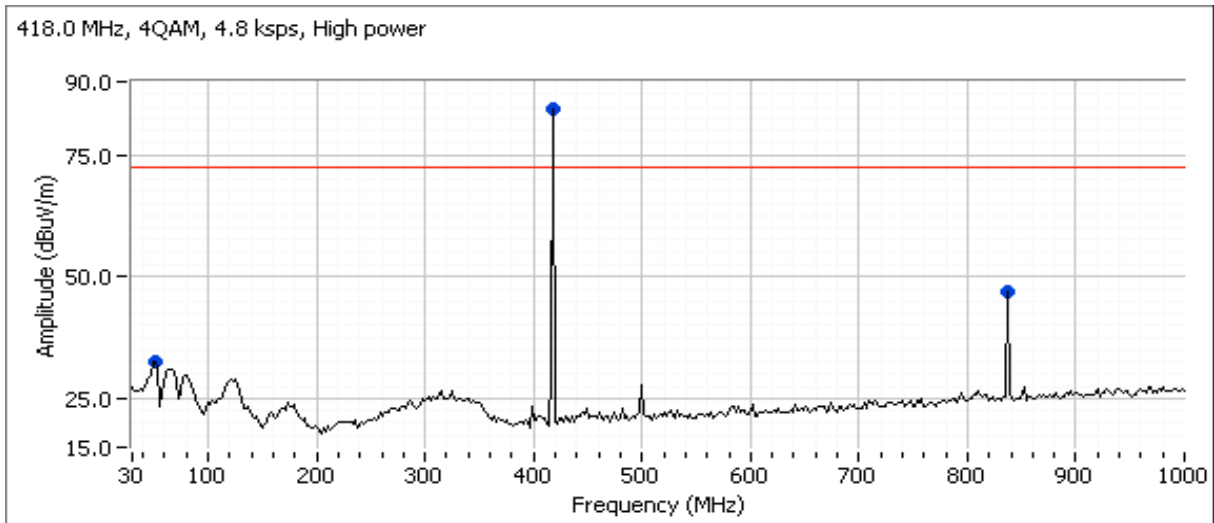

Client:	GE MDS LLC	Job Number:	J97704
Model:	LN400	T-Log Number:	T97706
Contact:	Dennis McCarthy	Project Manager:	Christine Krebill
Standard:	FCC Part 15, FCC Part 90, EN 300 113-2	Project Coordinator:	-
		Class:	A

Plots for high channel, power setting: High

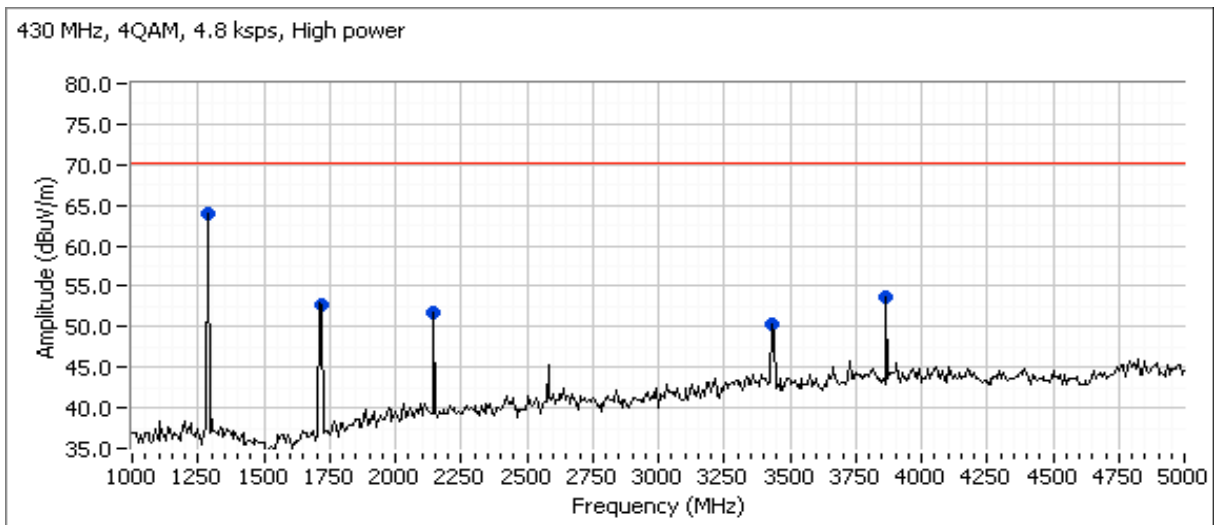
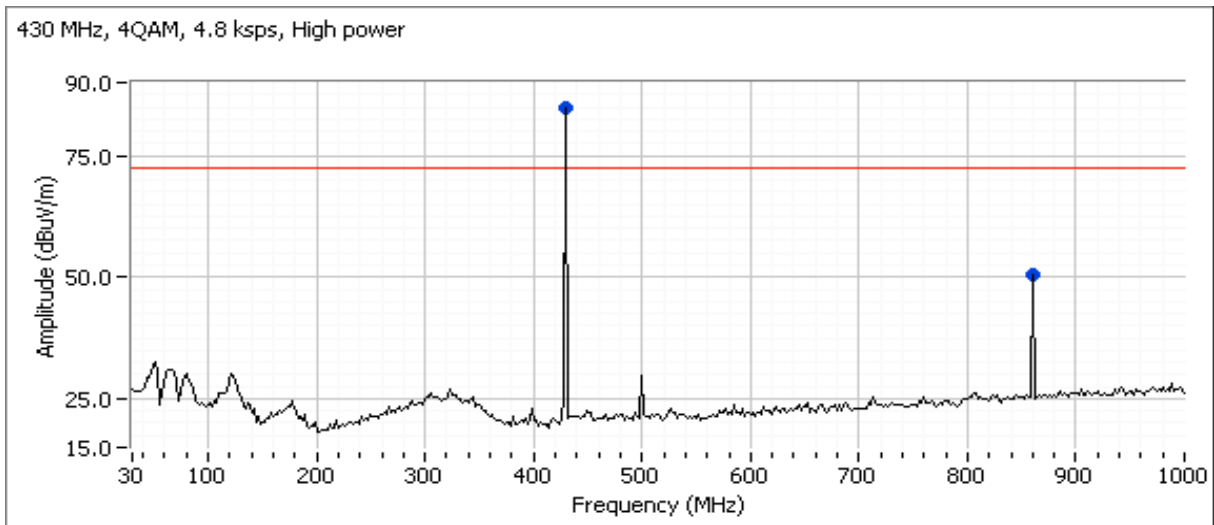

Client: GE MDS LLC	Job Number: J97704
Model: LN400	T-Log Number: T97706
	Project Manager: Christine Krebill
Contact: Dennis McCarthy	Project Coordinator: -
Standard: FCC Part 15, FCC Part 90, EN 300 113-2	Class: A

Plots for low channel, power setting: High

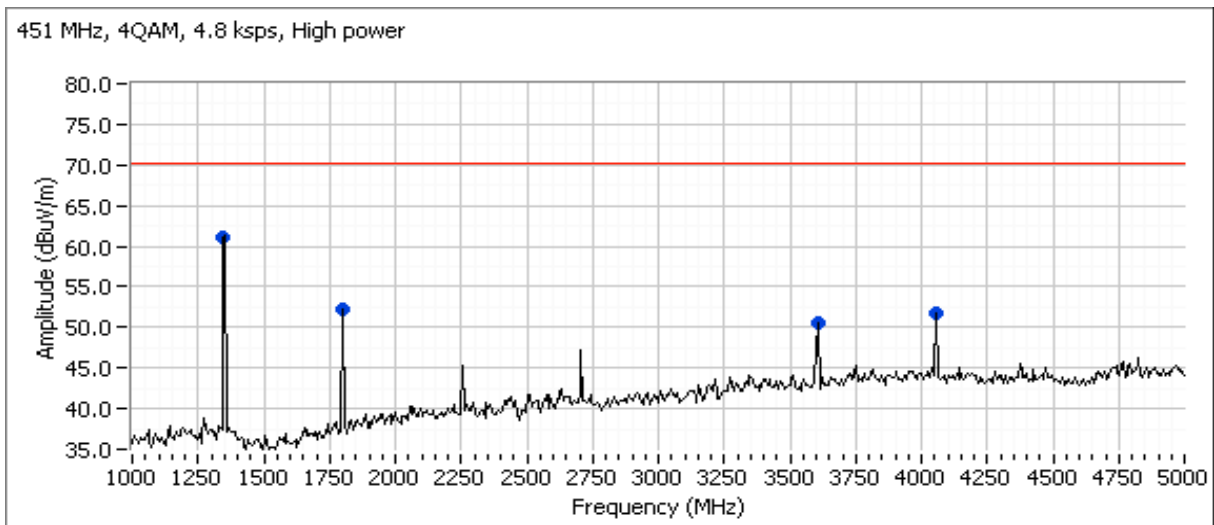
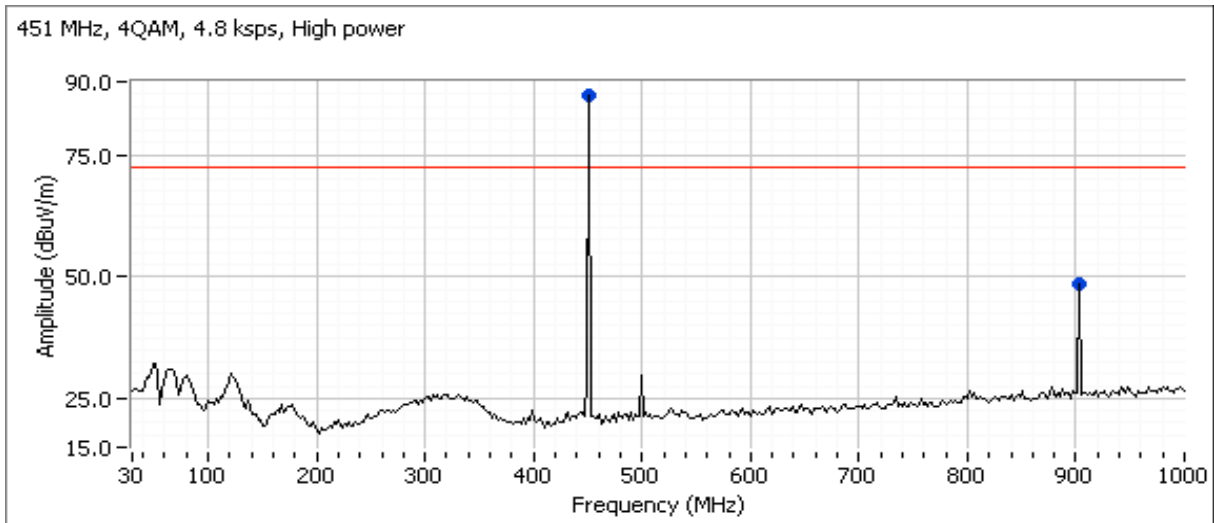

Client: GE MDS LLC	Job Number: J97704
Model: LN400	T-Log Number: T97706
	Project Manager: Christine Krebill
Contact: Dennis McCarthy	Project Coordinator: -
Standard: FCC Part 15, FCC Part 90, EN 300 113-2	Class: A

Plots for center channel, power setting: High

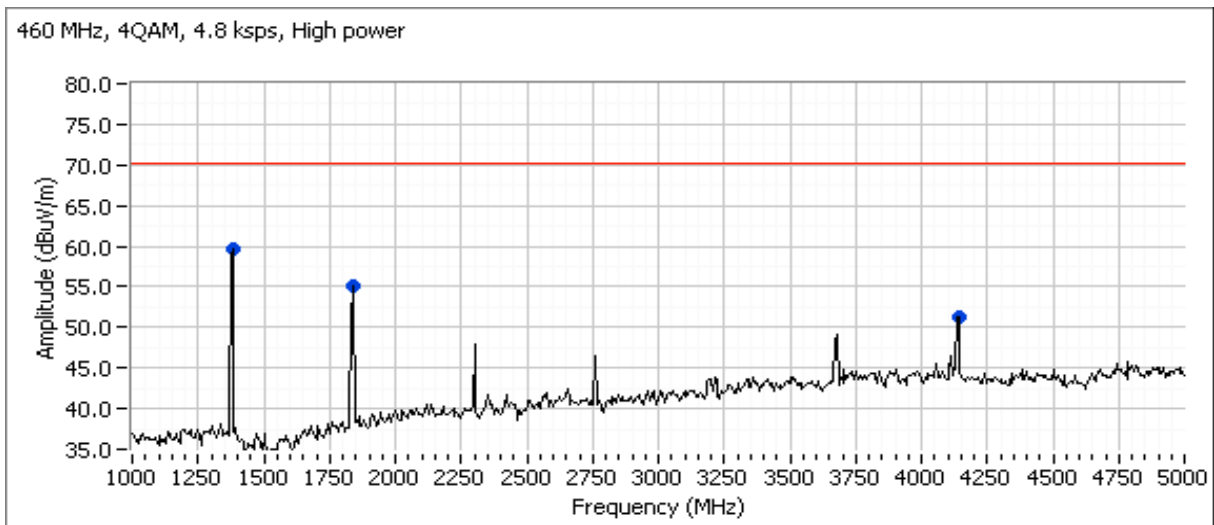
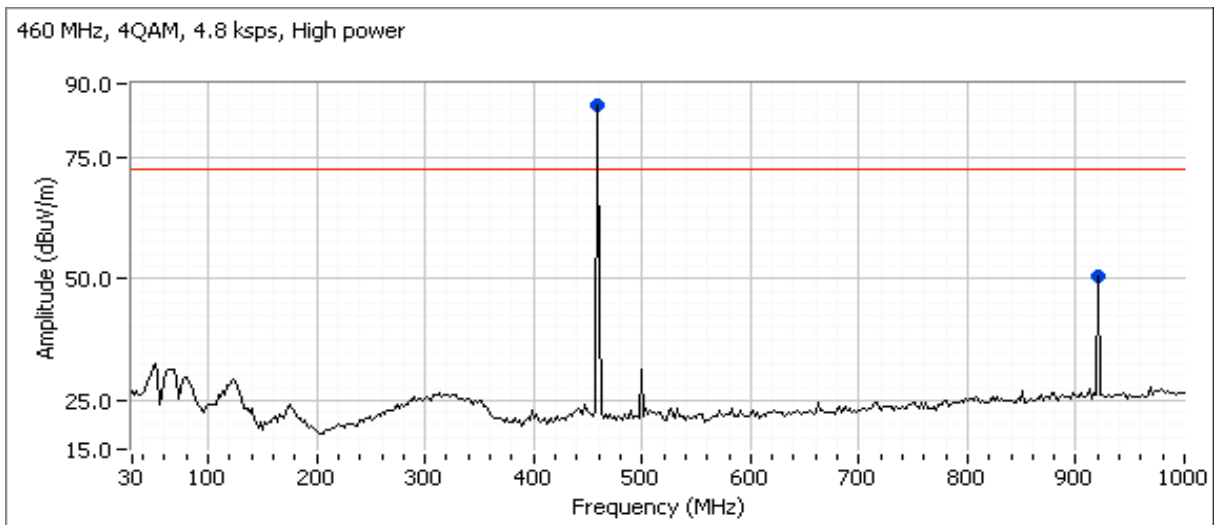

Client: GE MDS LLC	Job Number: J97704
Model: LN400	T-Log Number: T97706
	Project Manager: Christine Krebill
Contact: Dennis McCarthy	Project Coordinator: -
Standard: FCC Part 15, FCC Part 90, EN 300 113-2	Class: A

Plots for high channel, power setting: High

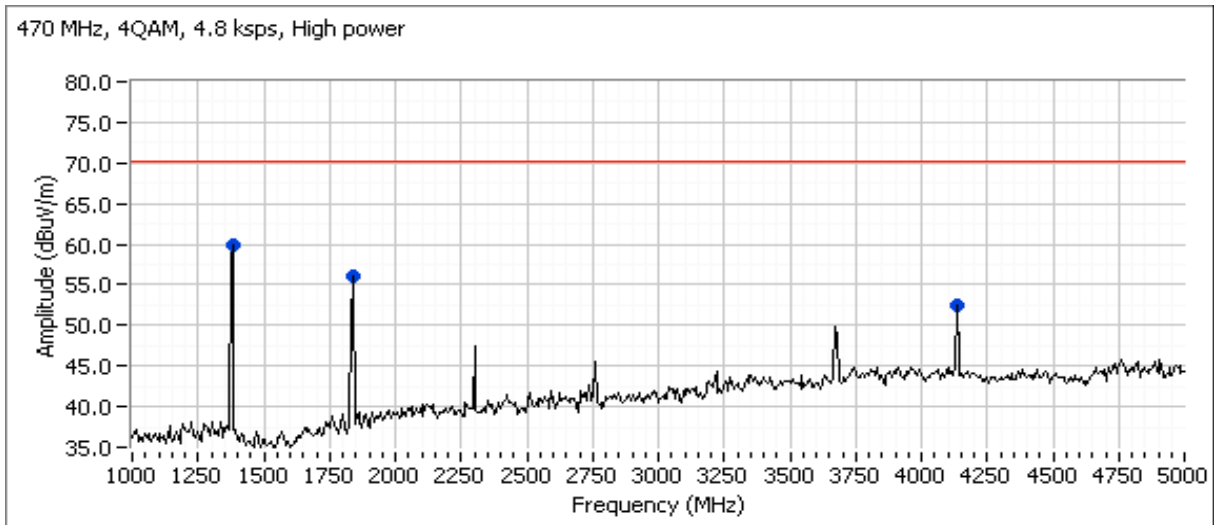
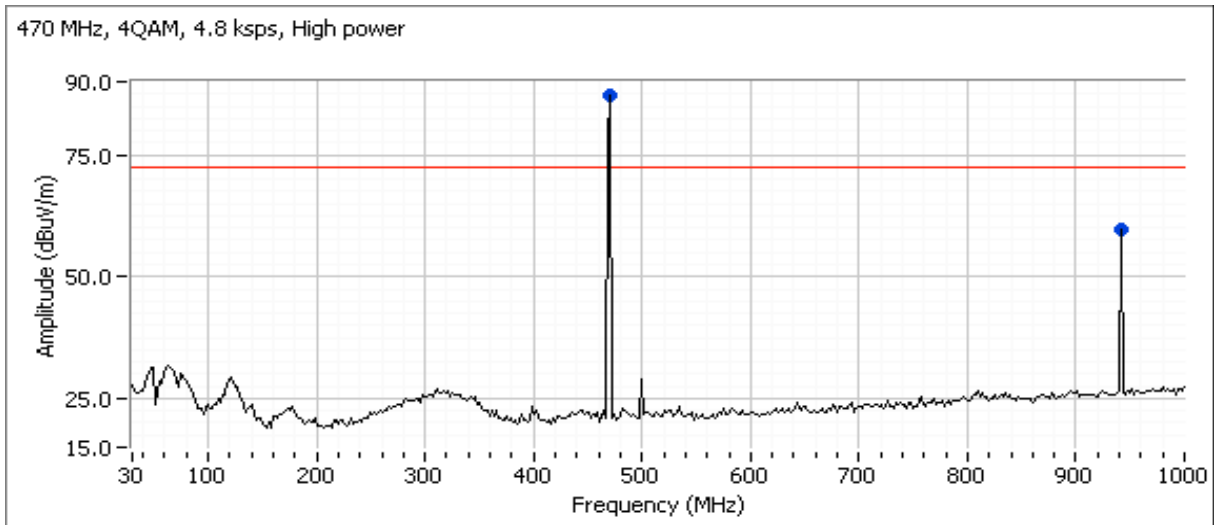



EMC Test Data

Client: GE MDS LLC	Job Number: J97704
Model: LN400	T-Log Number: T97706
	Project Manager: Christine Krebill
Contact: Dennis McCarthy	Project Coordinator: -
Standard: FCC Part 15, FCC Part 90, EN 300 113-2	Class: A

Run #5b: - Final EUT Field Strength Measurements and Substitution Measurements
 Date of Test: 4/28/2015; 4/30/2015 Config. Used: 1
 Test Engineer: Deniz Demirci; M. Birgani Config Change: none
 Test Location: FT Ch #3 EUT Voltage: 13.8 Vdc and 5 Vdc

EUT Field Strength

Frequency MHz	Level dB μ V/m	Pol v/h	FCC Part 90		Detector PK/QP/Avg	Azimuth degrees	Height meters	Comments	Channel
			Limit	Margin					
406.093	84.2	V	-	-	PK	131	2.5	Fundamental	406.1 MHz
812.203	46.7	V	72.4	-25.7	PK	232	1.0	PK (0.10s)	406.1 MHz
499.999	29.6	V	72.4	-42.8	PK	48	1.5	PK (0.10s)	406.1 MHz
51.097	32.5	H	72.4	-39.9	PK	220	1.0	PK (0.10s)	406.1 MHz
1217.860	59.9	H	70.2	-10.3	PK	207	1.0	RB 1 MHz;VB 3 MHz;Pe: 406.1 MHz	
1624.480	59.6	H	70.2	-10.6	PK	251	1.4	RB 1 MHz;VB 3 MHz;Pe: 406.1 MHz	
2030.530	52.6	V	70.2	-17.6	PK	220	1.0	RB 1 MHz;VB 3 MHz;Pe: 406.1 MHz	
3248.870	49.9	V	70.2	-20.3	PK	182	1.0	RB 1 MHz;VB 3 MHz;Pe: 406.1 MHz	
			0.0						
418.002	84.5	V	-	-	PK	145	2.0	Fundamental	418.0 MHz
51.397	32.5	H	72.4	-39.9	PK	201	1.0	PK (0.10s)	418.0 MHz
836.019	46.8	V	72.4	-25.6	PK	95	2.0	PK (0.10s)	418.0 MHz
1254.020	62.9	V	70.2	-7.3	PK	170	1.0	RB 1 MHz;VB 3 MHz;Pe: 418.0 MHz	
1672.130	53.0	H	70.2	-17.2	PK	201	1.3	RB 1 MHz;VB 3 MHz;Pe: 418.0 MHz	
2090.200	53.7	V	70.2	-16.5	PK	226	1.4	RB 1 MHz;VB 3 MHz;Pe: 418.0 MHz	
3343.930	51.2	H	70.2	-19.0	PK	225	1.2	RB 1 MHz;VB 3 MHz;Pe: 418.0 MHz	
3762.040	52.6	V	70.2	-17.6	PK	144	1.3	RB 1 MHz;VB 3 MHz;Pe: 418.0 MHz	
4180.080	52.8	H	70.2	-17.4	PK	210	1.1	RB 1 MHz;VB 3 MHz;Pe: 418.0 MHz	
			0.0						
429.992	85.0	V	-	-	PK	120	2.0	Fundamental	430.0 MHz
859.999	51.3	V	72.4	-21.1	PK	248	1.5	PK (0.10s)	430.0 MHz
1290.020	65.5	H	70.2	-4.7	PK	72	1.4	RB 1 MHz;VB 3 MHz;Pe: 430.0 MHz	
1720.060	53.6	V	70.2	-16.6	PK	197	1.4	RB 1 MHz;VB 3 MHz;Pe: 430.0 MHz	
2150.210	51.6	V	70.2	-18.6	PK	260	1.5	RB 1 MHz;VB 3 MHz;Pe: 430.0 MHz	
3440.010	51.2	V	70.2	-19.0	PK	82	1.8	RB 1 MHz;VB 3 MHz;Pe: 430.0 MHz	
3869.970	54.4	H	70.2	-15.8	PK	211	1.0	RB 1 MHz;VB 3 MHz;Pe: 430.0 MHz	

Note 1: The field strength limit in the tables above was calculated from the erp/eirp limit detailed in the standard using the free space propagation equation: $E = \sqrt{30PG}/d$. This limit is conservative - it does not consider the presence of the ground plane and, for erp limits, the dipole gain (2.2dBi) has not been included. The erp or eirp for all signals with less than 20dB of margin relative to this field strength limit is determined using substitution measurements.

Note 2: Measurements are made with the antenna port terminated.

Note 3: The limit is taken from FCC Part 90.210 Mask E (RSS-119 Mask E)



EMC Test Data

Client: GE MDS LLC	Job Number: J97704
Model: LN400	T-Log Number: T97706
Contact: Dennis McCarthy	Project Manager: Christine Krebill
Standard: FCC Part 15, FCC Part 90, EN 300 113-2	Project Coordinator: -
	Class: A

EUT Field Strength

Frequency MHz	Level dB μ V/m	Pol v/h	FCC Part 90		Detector Pk/QP/Avg	Azimuth degrees	Height meters	Comments	Channel
			Limit	Margin					
450.994	87.3	V	-	-	PK	126	2.0	Fundamental	451.0 MHz
902.003	48.8	V	72.4	-23.6	PK	283	2.2	PK (0.10s)	451.0 MHz
1353.050	62.0	V	70.2	-8.2	PK	54	1.9	RB 1 MHz;VB 3 MHz;Pe:	451.0 MHz
1804.080	55.6	H	70.2	-14.6	PK	219	1.1	RB 1 MHz;VB 3 MHz;Pe:	451.0 MHz
3608.050	51.3	H	70.2	-18.9	PK	177	1.0	RB 1 MHz;VB 3 MHz;Pe:	451.0 MHz
4058.910	56.6	V	70.2	-13.6	PK	285	1.7	RB 1 MHz;VB 3 MHz;Pe:	451.0 MHz
459.994	85.8	V	-	-	PK	116	2.0	Fundamental	460.0 MHz
920.015	52.1	H	72.4	-20.3	PK	216	1.1	PK (0.10s)	460.0 MHz
1380.050	62.1	V	70.2	-8.1	PK	26	1.9	RB 1 MHz;VB 3 MHz;Pe:	460.0 MHz
1839.920	59.6	H	70.2	-10.6	PK	138	1.6	RB 1 MHz;VB 3 MHz;Pe:	460.0 MHz
4139.460	56.9	V	70.2	-13.3	PK	160	1.0	RB 1 MHz;VB 3 MHz;Pe:	460.0 MHz
469.998	87.4	V	-	-	PK	121	2.0	Fundamental	470.0 MHz
940.009	60.3	H	72.4	-12.1	PK	209	1.0	PK (0.10s)	470.0 MHz
1380.090	61.1	V	70.2	-9.1	PK	22	1.8	RB 1 MHz;VB 3 MHz;Pe:	470.0 MHz
1839.950	58.4	H	70.2	-11.8	PK	138	1.2	RB 1 MHz;VB 3 MHz;Pe:	470.0 MHz
4139.840	58.7	H	70.2	-11.5	PK	190	1.0	RB 1 MHz;VB 3 MHz;Pe:	470.0 MHz

Note 1: The field strength limit in the tables above was calculated from the erp/eirp limit detailed in the standard using the free space propagation equation: $E = \sqrt{(30PG)/d}$. This limit is conservative - it does not consider the presence of the ground plane and, for erp limits, the dipole gain (2.2dBi) has not been included. The erp or eirp for all signals with less than 20dB of margin relative to this field strength limit is determined using substitution measurements.

Note 2: Measurements are made with the antenna port terminated.

Note 3: The limit is taken from FCC Part 90.210 Mask E (RSS-119 Mask E)



EMC Test Data

Client:	GE MDS LLC	Job Number:	J97704
Model:	LN400	T-Log Number:	T97706
Contact:	Dennis McCarthy	Project Manager:	Christine Krebill
Standard:	FCC Part 15, FCC Part 90, EN 300 113-2	Project Coordinator:	-
		Class:	A

Date of Test: 04/30/15
 Test Location: Chamber #3

Test Engineer: M. Birgani

Substitution measurements

Horizontal

Frequency MHz	Substitution measurements			Site Factor ⁴	EUT measurements			eirp Limit dBm	erp Limit dBm	Margin dB
	Pin ¹	Gain ²	FS ³		FS ⁵	eirp (dBm)	erp (dBm)			
940.0	-25.4	1.8	72.4	96.1	60.3	-35.8	-38.0		-25.0	-13.0
1218.0	-20.4	6.5	81.5	95.4	59.9	-35.5	-37.7		-25.0	-12.7
1290.0	-20.5	7.0	81.4	94.9	65.5	-29.4	-31.6		-25.0	-6.6
1624.0	-20.8	8.8	82.5	94.5	59.6	-34.9	-37.1		-25.0	-12.1
1672.0	-20.5	8.8	83.1	94.8	53.0	-41.8	-44.0		-25.0	-19.0
1804.0	-20.5	8.7	83.0	94.8	55.6	-39.2	-41.4		-25.0	-16.4
1840.0	-20.5	8.7	83.1	94.9	59.6	-35.3	-37.5		-25.0	-12.5
3344.0	-20.6	9.6	83.4	94.4	51.2	-43.2	-45.4		-25.0	-20.4
3608.0	-20.6	9.9	84.1	94.8	51.3	-43.5	-45.7		-25.0	-20.7
3870.0	-20.6	9.3	83.3	94.6	54.4	-40.2	-42.4		-25.0	-17.4
4140.0	-20.7	10.0	83.9	94.6	56.9	-37.7	-39.9		-25.0	-14.9
4180.0	-20.7	10.0	84.4	95.1	52.8	-42.3	-44.5		-25.0	-19.5

Vertical

Frequency MHz	Substitution measurements			Site Factor ⁴	EUT measurements			eirp Limit dBm	erp Limit dBm	Margin dB
	Pin ¹	Gain ²	FS ³		FS ⁵	eirp (dBm)	erp (dBm)			
1254.0	-20.5	6.9	82.1	95.7	62.9	-32.8	-35.0		-25.0	-10.0
1353.0	-20.5	7.4	81.6	94.7	62.0	-32.7	-34.9		-25.0	-9.9
1380.0	-20.6	7.7	82.0	94.9	62.1	-32.8	-35.0		-25.0	-10.0
1720.0	-20.5	8.4	82.0	94.1	53.6	-40.5	-42.7		-25.0	-17.7
2030.0	-20.5	8.9	83.2	94.8	52.6	-42.2	-44.4		-25.0	-19.4
2150.2	-20.5	9.1	53.5	64.9	51.6	-13.3	-15.5		-25.0	9.5
3440.0	-20.6	9.8	83.6	94.4	51.2	-43.2	-45.4		-25.0	-20.4
3762.0	-20.6	9.3	83.6	94.9	52.6	-42.3	-44.5		-25.0	-19.5
4058.0	-20.7	10.0	83.7	94.4	56.6	-37.8	-40.0		-25.0	-15.0

- Note 1: Pin is the input power (dBm) to the substitution antenna
- Note 2: Gain is the gain (dBi) for the substitution antenna.
- Note 3: FS is the field strength (dBuV/m) measured from the substitution antenna.
- Note 4: Site Factor - this is the site factor to convert from a field strength in dBuV/m to an eirp in dBm.
- Note 5: EUT field strength as measured during initial run.

Client:	GE MDS LLC	Job Number:	J97704
Model:	LN400	T-Log Number:	T97706
Contact:	Dennis McCarthy	Project Manager:	Christine Krebill
Standard:	FCC Part 15, FCC Part 90, EN 300 113-2	Project Coordinator:	-
		Class:	A

Run #6: Transient Frequency Behavior

Date of Test: 28-Apr-15
 Test Engineer: Deniz Demirci
 Test Location: FT Lab #4

Config. Used: 1
 Config Change: none
 EUT Voltage: 13.8 VDC

Transient frequency Behavior measurements setup

Note: The test has been performed using the method given in ANSI / TIA 603-C (2.2.19)

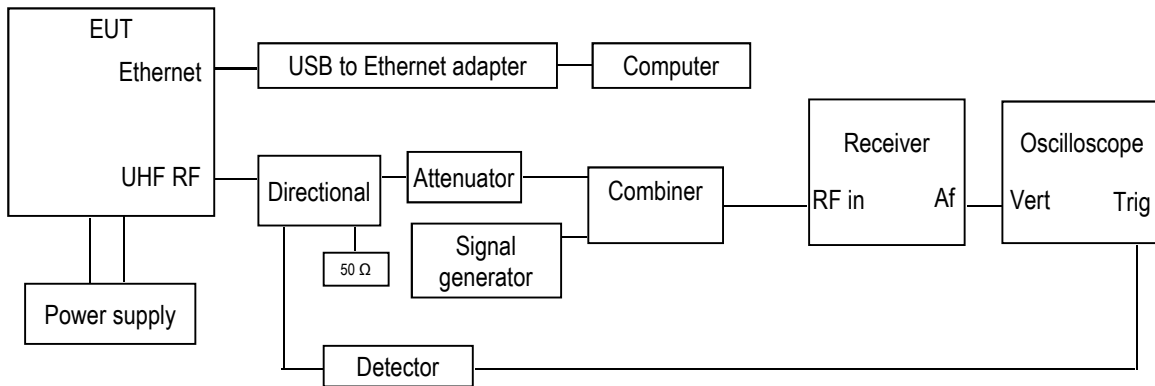

Client: GE MDS LLC	Job Number: J97704
Model: LN400	T-Log Number: T97706
	Project Manager: Christine Krebill
Contact: Dennis McCarthy	Project Coordinator: -
Standard: FCC Part 15, FCC Part 90, EN 300 113-2	Class: A

Run #6a

Carrier Frequency: 451 MHz

Channel Spacing: 25 kHz

Modulation: CW

Description: Switch on condition ton, t1, and t2

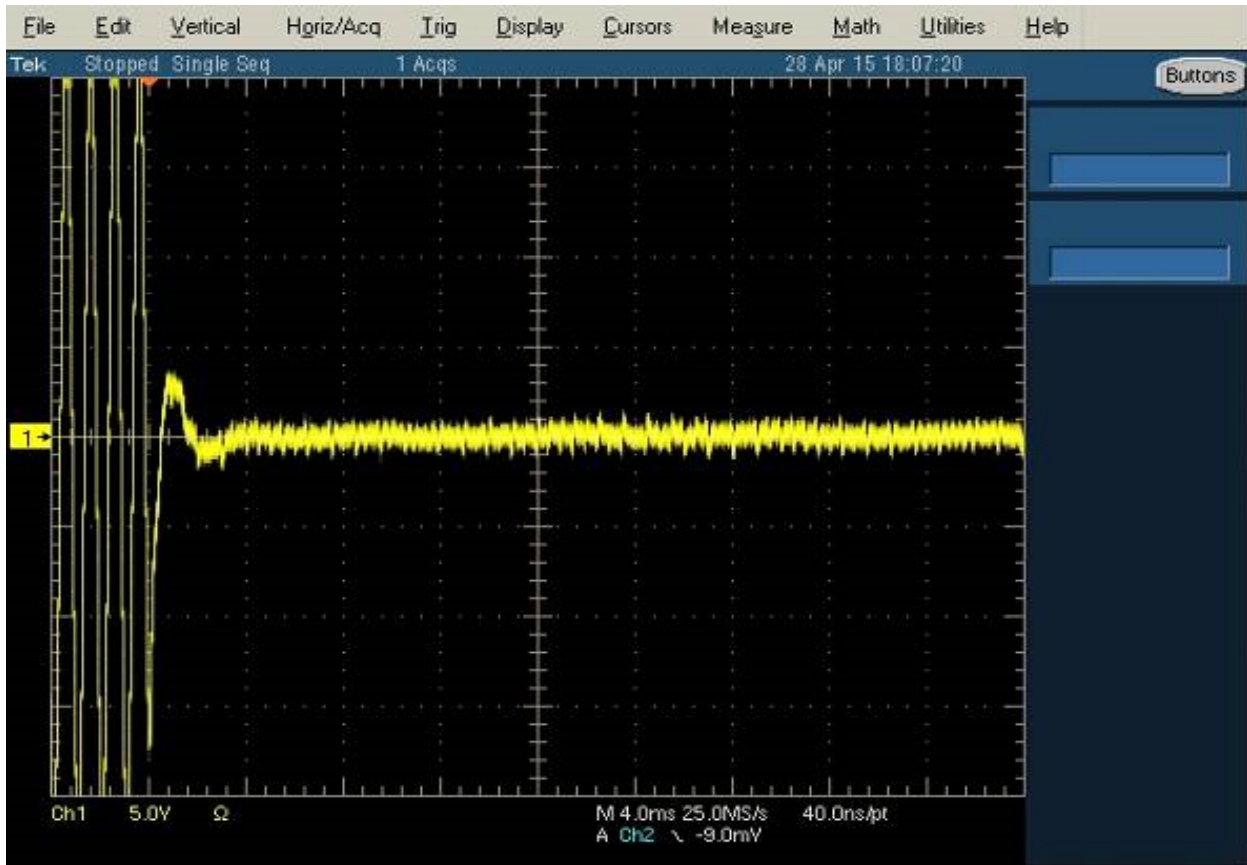

Client: GE MDS LLC	Job Number: J97704
Model: LN400	T-Log Number: T97706
	Project Manager: Christine Krebill
Contact: Dennis McCarthy	Project Coordinator: -
Standard: FCC Part 15, FCC Part 90, EN 300 113-2	Class: A

Run #6b
 Carrier Frequency: 451 MHz
 Channel Spacing: 25 kHz
 Modulation: CW
 Description: Switch off condition t3 and toff

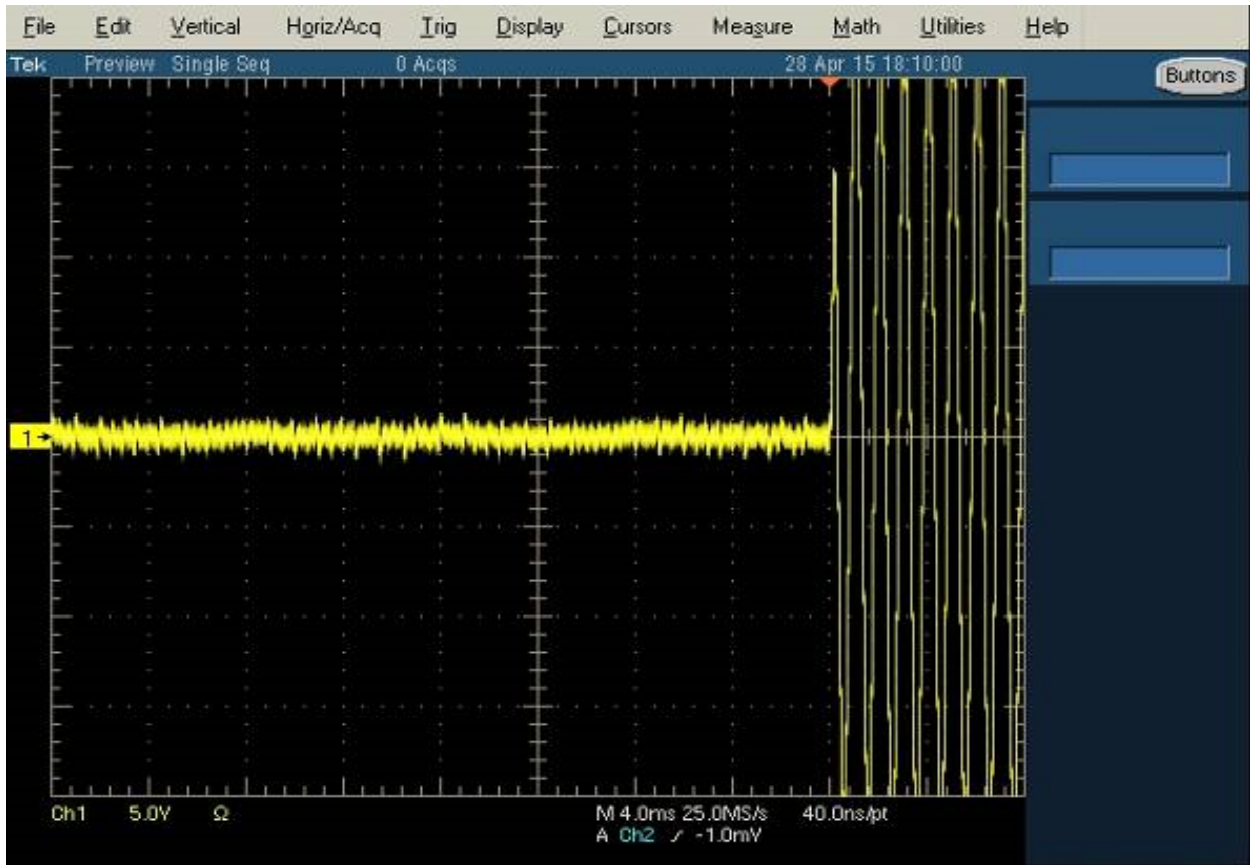



EMC Test Data

Client: GE MDS LLC	Job Number: J97704
Model: LN400	T-Log Number: T97706
	Project Manager: Christine Krebill
Contact: Dennis McCarthy	Project Coordinator: -
Standard: FCC Part 15, FCC Part 90, EN 300 113-2	Class: A

Run #7: Frequency Stability

Date of Test: 28-Apr-15
 Test Engineer: Deniz Demirci
 Test Location: FT Lab #4

Config. Used: 1
 Config Change: none
 EUT Voltage: 13.8 VDC

Nominal Frequency: 451.0000 MHz

Frequency Stability Over Temperature

The EUT was soaked at each temperature for a minimum of 30 minutes prior to making the measurements to ensure the EUT and chamber had stabilized at that temperature.

Temperature (Celsius)	Frequency Measured (MHz)	Drift	
		(Hz)	(ppm)
-30	450.999950	-50	0.1
-20	450.999950	-50	0.1
-10	450.999950	-50	0.1
0	451.000050	50	0.1
10	451.000050	50	0.1
20	451.000050	50	0.1
30	451.000050	50	0.1
40	451.000050	50	0.1
50	451.000050	50	0.1
Worst case:		-50	0.1

Frequency Stability Over Input Voltage

Nominal Voltage range is 11.8 - 52.2 Vdc.

Voltage (DC)	Frequency Measured (MHz)	Drift	
		(Hz)	(ppm)
10.0	451.000050	50	0.1
60.0	451.000050	50	0.1
Worst case:		50	0.1

63.8

Note 1: Maximum drift of fundamental frequency before it shut down at 9.4 Vdc is 50 Hz.

Client: GE MDS LLC	Job Number: J97704
Model: LN400	T-Log Number: T97706
Contact: Dennis McCarthy	Project Manager: Christine Krebill
Standard: FCC Part 15, FCC Part 90, EN 300 113-2	Project Coordinator: -
	Class: A

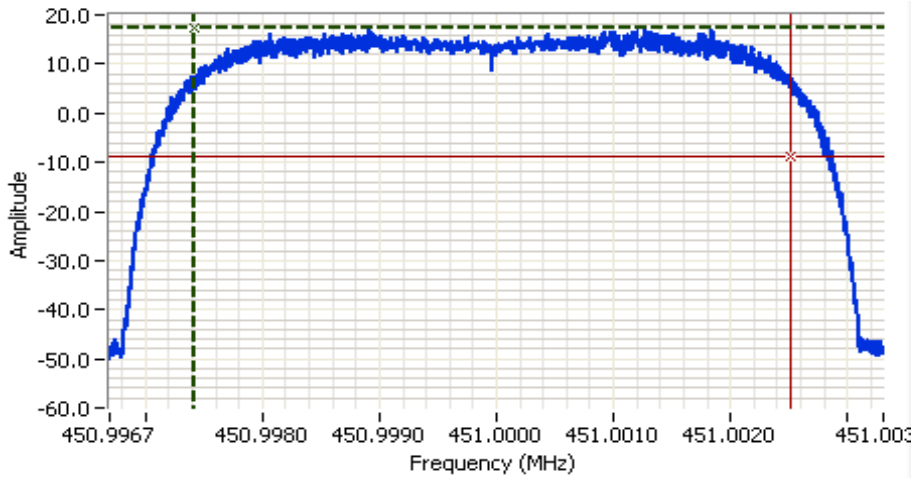

Analyzer Settings
 Agilent Technologies, E4446A
 CF: 451.000 MHz
 SPAN: 6.61 kHz
 RB: 10 Hz
 VB: 100 Hz
 Detector: POS
 Attn: 40 DB
 RL Offset: 20.0 DB
 Sweep Time: 0.5s
 Ref Lvl: 50.0 DBM

Comments
 99% power BW: 5.10 kHz
 Power over span: 40.43dBm
 -30 degree
 Freq: 450.999950 MHz

Cursor 1 450.9974 17.2

Cursor 2 451.0025 -8.8

Delta Freq. 5.10 kHz

Delta Amplitude 26.0

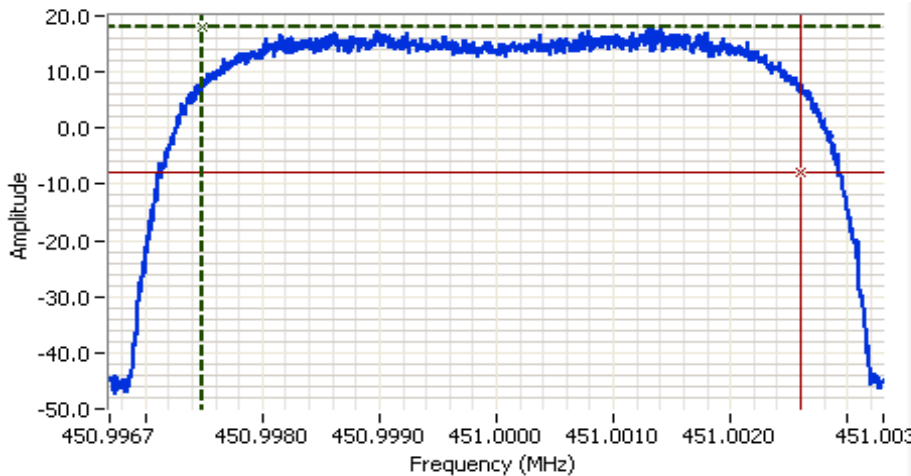

Analyzer Settings
 Agilent Technologies, E4446A
 CF: 451.000 MHz
 SPAN: 6.61 kHz
 RB: 10 Hz
 VB: 100 Hz
 Detector: POS
 Attn: 40 DB
 RL Offset: 20.0 DB
 Sweep Time: 0.5s
 Ref Lvl: 50.0 DBM

Comments
 99% power BW: 5.12 kHz
 Power over span: 41.33dBm
 50 degree
 Freq: 451.000050 MHz

Cursor 1 450.9975 18.2

Cursor 2 451.0026 -7.8

Delta Freq. 5.12 kHz

Delta Amplitude 26.0



Client: GE MDS LLC	Job Number: J97704
Model: LN400	T-Log Number: T97706
Contact: Dennis McCarthy	Project Manager: Christine Krebill
Standard: FCC Part 15, FCC Part 90, EN 300 113-2	Project Coordinator: -
	Class: A

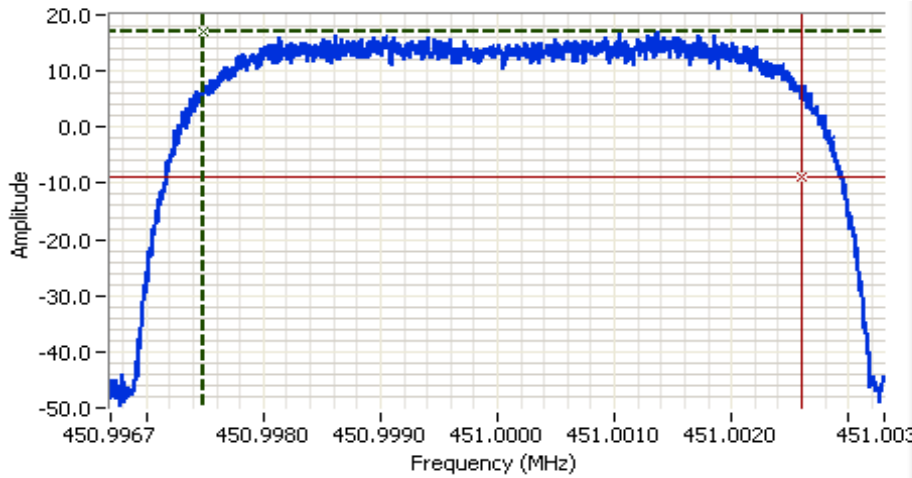

Analyzer Settings
 Agilent Technologies, E4446A
 CF: 451.000 MHz
 SPAN: 6.61 kHz
 RB: 10 Hz
 VB: 100 Hz
 Detector: POS
 Attn: 40 DB
 RL Offset: 20.0 DB
 Sweep Time: 0.5s
 Ref Lvl: 50.0 DBM

Comments
 99% power BW: 5.11 kHz
 Power over span: 40.21dBm
 20 degree, 9.4 VDC
 Freq: 451.000050 MHz

Cursor 1 450.9975 17.0

Cursor 2 451.0026 -9.0

Delta Freq. 5.11 kHz

Delta Amplitude 26.0

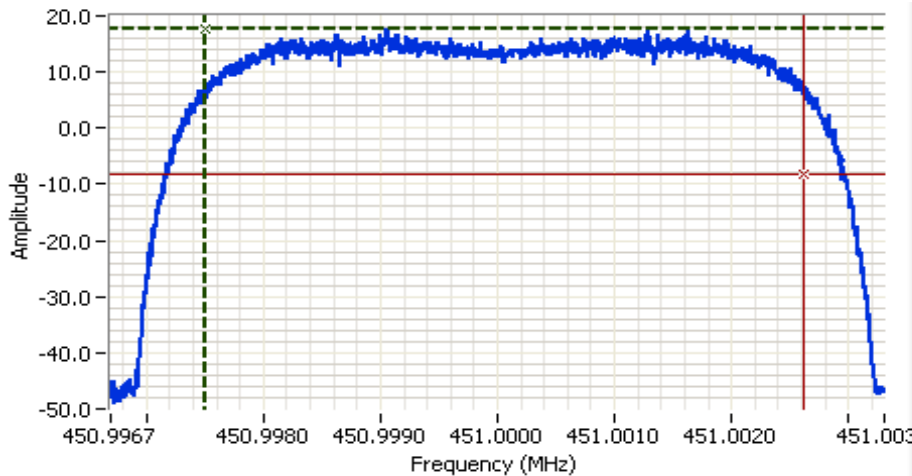

Analyzer Settings
 Agilent Technologies, E4446A
 CF: 451.000 MHz
 SPAN: 6.61 kHz
 RB: 10 Hz
 VB: 100 Hz
 Detector: POS
 Attn: 40 DB
 RL Offset: 20.0 DB
 Sweep Time: 0.5s
 Ref Lvl: 50.0 DBM

Comments
 99% power BW: 5.12 kHz
 Power over span: 40.70dBm
 20 degree, 60 VDC
 Freq: 451.000050 MHz

Cursor 1 450.9975 17.7

Cursor 2 451.0026 -8.3

Delta Freq. 5.12 kHz

Delta Amplitude 26.0





EMC Test Data

Client:	GE MDS LLC	Job Number:	J97704
Model:	LN400	T-Log Number:	T97706
Contact:	Dennis McCarthy	Project Manager:	Christine Krebill
Standard:	FCC Part 15, FCC Part 90, EN 300 113-2	Project Coordinator:	-
		Class:	N/A

Conducted Emissions

(Elliott Laboratories Fremont Facility, Semi-Anechoic Chamber)

Test Specific Details

Objective: The objective of this test session is to perform final qualification testing of the EUT with respect to the specification listed above.

Date of Test: 28-Apr-15
 Test Engineer: Deniz Demirci
 Test Location: FT Lab #4

Config. Used: 1
 Config Change: none
 EUT Voltage: 13.8 VDC

General Test Configuration

All measurements are made with the EUT's rf port connected to the measurement instrument via an attenuator or dc-block if necessary. All amplitude measurements are adjusted to account for the attenuation between EUT and measuring instrument.

Ambient Conditions:

Temperature: 20-22 °C
 Rel. Humidity: 30-45 %

Summary of Results

Run #	Test Performed	Limit	Result	Margin
1	Conducted Emissions 30 - 2000 MHz	FCC Part 15.111 (2 nW)	Pass	-13.1 dB (Highest noise floor reading)

Modifications Made During Testing

No modifications were made to the EUT during testing

Deviations From The Standard

No deviations were made from the requirements of the standard.

Sample Note

Sample S/N:2648639



EMC Test Data

Client:	GE MDS LLC	Job Number:	J97704
Model:	LN400	T-Log Number:	T97706
Contact:	Dennis McCarthy	Project Manager:	Christine Krebill
Standard:	FCC Part 15, FCC Part 90, EN 300 113-2	Project Coordinator:	-
		Class:	N/A

Run #1: Conducted Spurious Emissions, 30 - 2000 MHz

Test at 406.1, 451 and 470 MHz

Frequency MHz	Level dBm	Port	FCC Part 15		Detector Pk/QP/Avg	Comments	Channel
			Limit	Margin			
1664.330	-70.6	RF Port	-57.0	-13.6	Peak	Highest noise floor reading	406.1 MHz
1686.340	-70.5	RF Port	-57.0	-13.5	Peak	Highest noise floor reading	451.0 MHz
1850.430	-70.1	RF Port	-57.0	-13.1	Peak	Highest noise floor reading	470.0 MHz

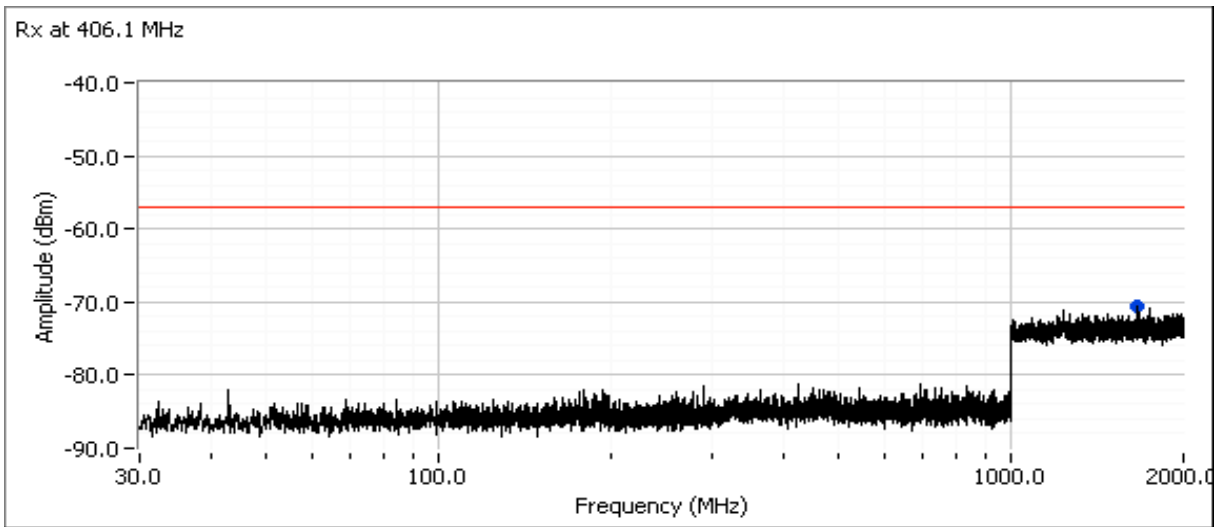

Client: GE MDS LLC	Job Number: J97704
Model: LN400	T-Log Number: T97706
Contact: Dennis McCarthy	Project Manager: Christine Krebill
Standard: FCC Part 15, FCC Part 90, EN 300 113-2	Project Coordinator: -
	Class: N/A

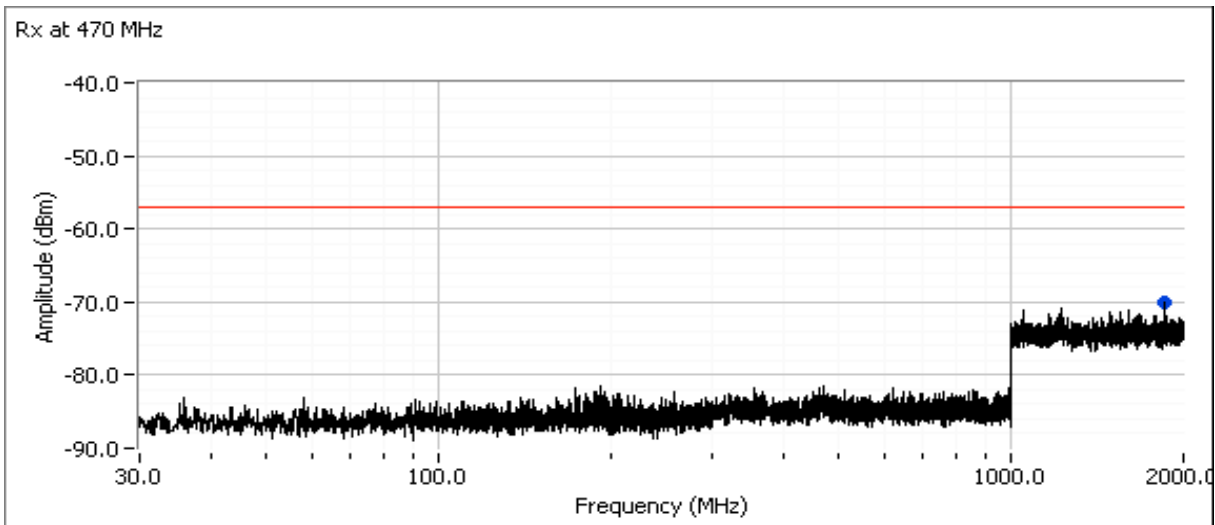
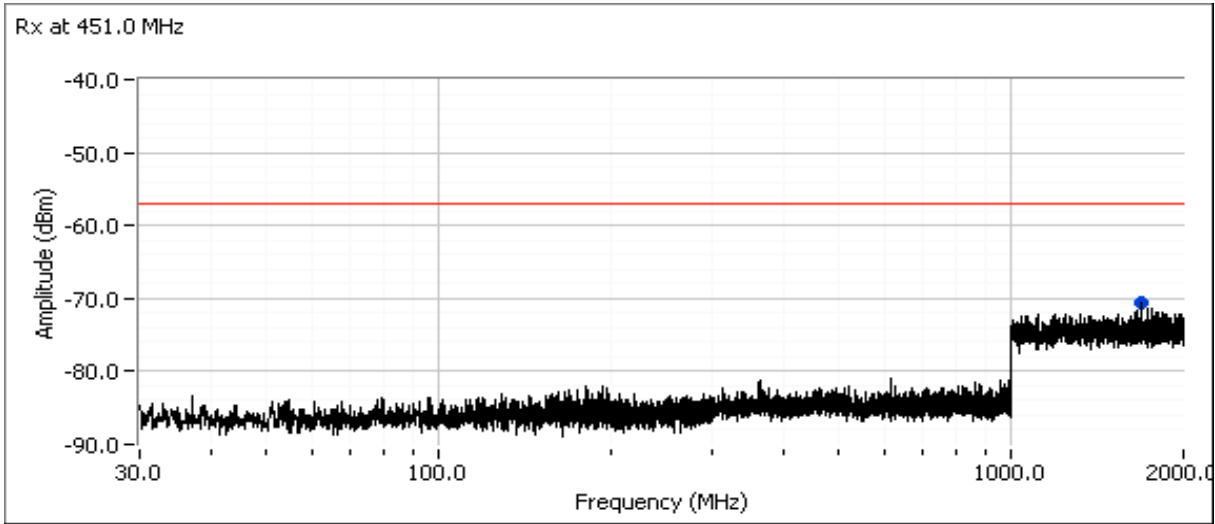



EMC Test Data

Client:	GE MDS LLC	Job Number:	J97704
Model:	LN400	T-Log Number:	T97706
		Project Manager:	Christine Krebill
Contact:	Dennis McCarthy	Project Coordinator:	-
Standard:	FCC Part 15, FCC Part 90, EN 300 113-2	Class:	A

Radiated Emissions (Receiver)

(Elliott Laboratories Fremont Facility, Semi-Anechoic Chamber)

Test Specific Details

Objective: The objective of this test session is to perform final qualification testing of the EUT with respect to the specification listed above.

Date of Test: 5/1/2015
 Test Engineer: Deniz Demirci
 Test Location: FT Ch #3

Config. Used: 1
 Config Change: None
 EUT Voltage: 13.8 Vdc and 5 Vdc

General Test Configuration

The EUT was located on the turntable for radiated emissions testing. No remote support equipment was used. Radiated emissions tests above 1 GHz to FCC Part 15 were performed with floor absorbers in place in accordance with the test methods of ANSI C63.4:2014.

The test distance and extrapolation factor (if applicable) are detailed under each run description.

Note, preliminary testing indicates that the emissions were maximized by orientation of the EUT and elevation of the measurement antenna. Maximized testing indicated that the emissions were maximized by orientation of the EUT, elevation of the measurement antenna, and manipulation of the EUT's interface cables.

Ambient Conditions:

Temperature: 20-22 °C
 Rel. Humidity: 30-35 %

Summary of Results

Run #	Test Performed	Limit	Result	Margin
1	Radiated Emissions 30 - 2000 MHz, Preliminary	FCC Part 15	Eval	Refer to individual runs
2	Radiated Emissions 30 - 2000 MHz, Maximized	FCC Part 15	Pass	23.0 dBµV/m @ 54.96 MHz (-17.0 dB)

Modifications Made During Testing

No modifications were made to the EUT during testing

Deviations From The Standard

No deviations were made from the requirements of the standard.

Sample Note

Sample S/N:2648639 - 1216163

Client:	GE MDS LLC	Job Number:	J97704
Model:	LN400	T-Log Number:	T97706
Contact:	Dennis McCarthy	Project Manager:	Christine Krebill
Standard:	FCC Part 15, FCC Part 90, EN 300 113-2	Project Coordinator:	-
		Class:	A

Run #1: Preliminary Radiated Emissions, 30 - 2000 MHz

Test Parameters for Preliminary Scan(s)			
Frequency Range (MHz)	Prescan Distance (meters)	Limit Distance (meters)	Extrapolation Factor (dB, applied to data)
30 - 2000	3	3	0.0

Preliminary peak readings captured during pre-scan

Frequency MHz	Level dB μ V/m	Pol v/h	FCC Part 15		Detector Pk/QP/Avg	Azimuth degrees	Height meters	Comments
			Limit	Margin				
54.890	23.8	V	40.0	-16.2	Peak	291	1.0	
61.383	24.5	V	40.0	-15.5	Peak	261	1.0	
197.735	19.0	H	43.5	-24.5	Peak	290	1.0	
325.250	23.6	H	46.0	-22.4	Peak	244	1.0	
499.198	26.4	V	46.0	-19.6	Peak	95	1.0	
725.050	21.7	H	46.0	-24.3	Peak	109	1.0	
1976.670	35.8	H	54.0	-18.2	Peak	133	2.0	Noise floor reading

- Note 1: The serial port and Ethernet port are mutually exclusive. Preliminary tests showed that emissions were highest with respect to the limits with the Ethernet port. Therefore this configuration was used for final measurements.
- Note 2: Preliminary tests showed that digital circuitry and receiver emissions from the EUT are independent of the selected receive frequency. Therefore final tests were performed with the receiver set at 451 MHz.

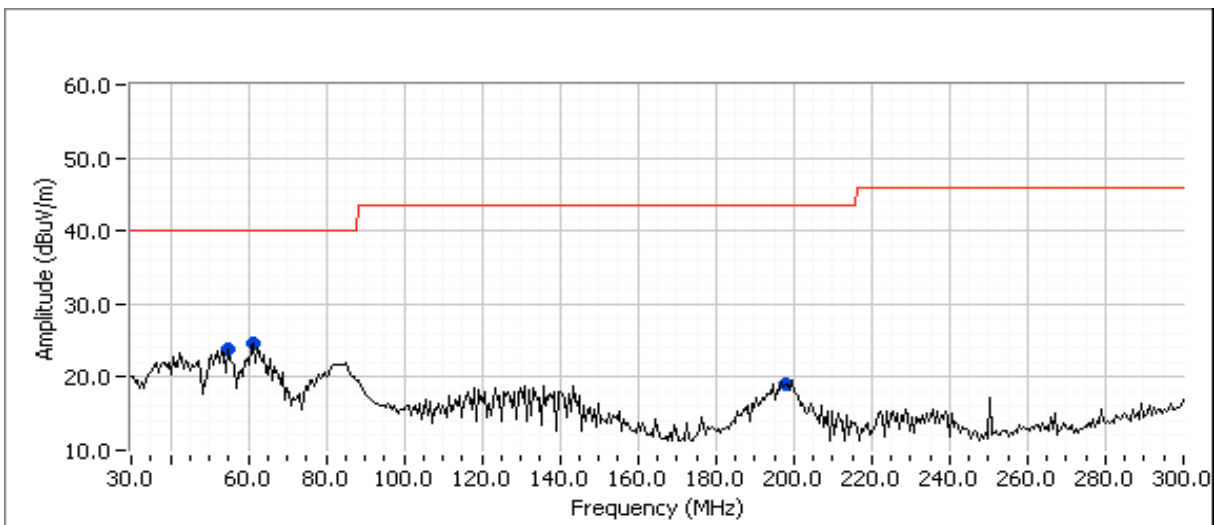

Client:	GE MDS LLC	Job Number:	J97704
Model:	LN400	T-Log Number:	T97706
Contact:	Dennis McCarthy	Project Manager:	Christine Krebill
Standard:	FCC Part 15, FCC Part 90, EN 300 113-2	Project Coordinator:	-
		Class:	A

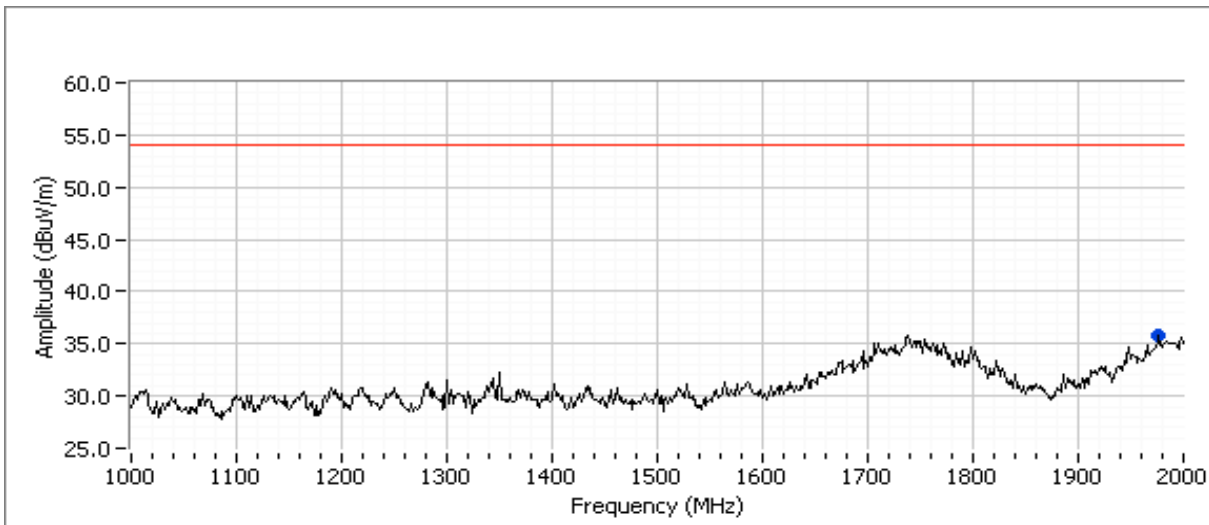
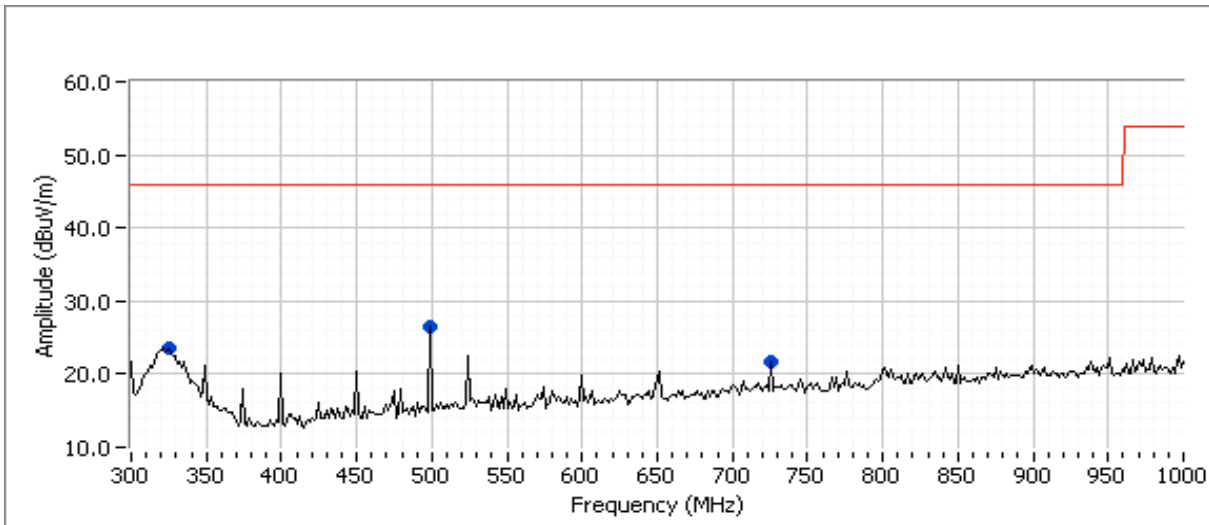



EMC Test Data

Client:	GE MDS LLC	Job Number:	J97704
Model:	LN400	T-Log Number:	T97706
Contact:	Dennis McCarthy	Project Manager:	Christine Krebill
Standard:	FCC Part 15, FCC Part 90, EN 300 113-2	Project Coordinator:	-
		Class:	A

Run #2: Maximized Readings From Run #1

Test Parameters for Maximized Reading(s)			
Frequency Range (MHz)	Test Distance (meters)	Limit Distance (meters)	Extrapolation Factor (dB, applied to data)
30 - 2000	3	3	0.0

Maximized quasi-peak readings (includes manipulation of EUT interface cables)

Frequency MHz	Level dB μ V/m	Pol v/h	FCC Part 15		Detector Pk/QP/Avg	Azimuth degrees	Height meters	Comments
			Limit	Margin				
54.963	23.0	V	40.0	-17.0	QP	258	1.0	QP (1.00s)
61.029	22.9	V	40.0	-17.1	QP	258	1.0	QP (1.00s)
500.009	25.9	V	46.0	-20.1	QP	91	1.0	QP (1.00s)
324.389	22.3	H	46.0	-23.7	QP	244	1.0	QP (1.00s)
725.002	20.6	H	46.0	-25.4	QP	90	1.1	QP (1.00s)
197.368	17.9	H	43.5	-25.6	QP	263	1.0	QP (1.00s)

End of Report

This page is intentionally blank and marks the last page of this test report.