

ENGINEERING TEST REPORT

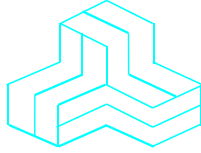

TransNet
Model No.: EL805

FCC ID: E5MDS-EL805

Applicant:

Microwave Data Systems Inc.
175 Science Parkway
Rochester, NY
USA, 14620

In Accordance With

Federal Communications Commission (FCC)
Part 15, Subpart C, Section 15.247
Frequency Hopping Spread Spectrum Transmitters
Operating in the Frequency band 902.2 - 927.8 MHz

UltraTech's File No.: MIC-077F15C

This Test report is Issued under the Authority of
Tri M. Luu, Professional Engineer,
Vice President of Engineering
UltraTech Group of Labs

Date: October 9, 2002



Report Prepared by: Dan Huynh

Tested by: Mr. Hung Trinh, EMI/RFI Technician

Issued Date: October 9, 2002

Test Dates: October 6-9, 2002

- *The results in this Test Report apply only to the sample(s) tested, and the sample tested is randomly selected.*
- *This report must not be used by the client to claim product endorsement by NVLAP or any agency of the US Government.*

UltraTech

3000 Bristol Circle, Oakville, Ontario, Canada, L6H 6G4
Tel.: (905) 829-1570 Fax.: (905) 829-8050

Website: www.ultratech-labs.com Email: vic@ultratech-labs.com Email: tri.luu@sympatico.ca

31040/SIT

C-1376

46390-2049

200093-0

00-034



TABLE OF CONTENTS

EXHIBIT 1. SUBMITTAL CHECK LIST.....	1
EXHIBIT 2. INTRODUCTION	2
2.1. SCOPE.....	2
2.2. RELATED SUBMITTAL(S)/GRANT(S).....	2
2.3. NORMATIVE REFERENCES	2
EXHIBIT 3. PERFORMANCE ASSESSMENT	3
3.1. CLIENT INFORMATION	3
3.2. EQUIPMENT UNDER TEST (EUT) INFORMATION.....	3
3.3. EUT'S TECHNICAL SPECIFICATIONS.....	4
3.4. LIST OF EUT'S PORTS	4
3.5. ANCILLARY EQUIPMENT	4
3.6. ASSOCIATED ANTENNA SPECIFICATIONS.....	5
EXHIBIT 4. EUT OPERATING CONDITIONS AND CONFIGURATIONS DURING TESTS.....	7
4.1. CLIMATE TEST CONDITIONS	7
4.2. OPERATIONAL TEST CONDITIONS & ARRANGEMENT FOR TESTS	7
EXHIBIT 5. SUMMARY OF TEST RESULTS	8
5.1. LOCATION OF TESTS	8
5.2. APPLICABILITY & SUMMARY OF EMC EMISSION TEST RESULTS	8
5.3. MODIFICATIONS INCORPORATED IN THE EUT FOR COMPLIANCE PURPOSES	8
EXHIBIT 6. MEASUREMENTS, EXAMINATIONS & TEST DATA FOR EMC EMISSIONS.....	9
6.1. TEST PROCEDURES	9
6.2. MEASUREMENT UNCERTAINTIES	9
6.3. MEASUREMENT EQUIPMENT USED.....	9
6.4. ESSENTIAL/PRIMARY FUNCTIONS AS DECLARED BY THE MANUFACTURER.....	9
6.5. PEAK OUTPUT POWER & EQUIVALENT ISOTROPIC RADIATED POWER (EIRP) [47 CFR § 15.247(B)]	10
6.5.1. <i>Limits</i>	10
6.5.2. <i>Method of Measurements</i>	10
6.5.3. <i>Test Arrangement</i>	10
6.5.4. <i>Test Equipment List</i>	10
6.5.5. <i>Test Data</i>	11
6.6. RF EXPOSURE REQUIREMENTS [47 CFR §§ 15.247(B)(4), 1.1310 & 2.1091].....	12
6.6.1. <i>Limits</i>	12
6.6.2. <i>Method of Measurements</i>	12
6.6.3. <i>Test Data</i>	14
6.7. TRANSMITTER SPURIOUS RADIATED EMISSIONS AT 3 METERS [47 CFR §§ 15.247(c), 15.209 & 15.205].....	15
6.7.1. <i>Limits</i>	15
6.7.2. <i>Method of Measurements</i>	16
6.7.3. <i>Test Arrangement</i>	16
6.7.4. <i>Test Equipment List</i>	17
6.7.5. <i>Test Data</i>	17
EXHIBIT 7. MEASUREMENT UNCERTAINTY.....	24
7.1. RADIATED EMISSION MEASUREMENT UNCERTAINTY.....	24

EXHIBIT 8. MEASUREMENT METHODS	25
8.1. GENERAL TEST CONDITIONS.....	25
8.1.1. Normal temperature and humidity.....	25
8.1.2. Normal power source	25
8.1.3. Operating Condition of Equipment under Test.....	25
8.2. EQUIVALENT ISOTROPIC RADIATED POWER (EIRP).....	26
8.3. SPURIOUS EMISSIONS (CONDUCTED & RADIATED)	29
8.3.1. Band-Edge and Spurious Emissions (Conducted).....	29
8.3.2. Spurious Emissions (Radiated).....	30

EXHIBIT 1. SUBMITTAL CHECK LIST

Annex No.	Exhibit Type	Description of Contents	Quality Check (OK)
--	Test Report	<ul style="list-style-type: none"> • Exhibit 1: Submittal check lists • Exhibit 2: Introduction • Exhibit 3: Performance Assessment • Exhibit 4: EUT Operation and Configuration during Tests • Exhibit 5: Summary of test Results • Exhibit 6: Measurement Data • Exhibit 7: Measurement Uncertainty • Exhibit 8: Measurement Methods 	OK
1	Test Setup Photos	Radiated Emissions Test Setup Photos	OK
2	External Photos of EUT	External EUT and Antennas Photos	OK
3	Internal Photos of EUT	Refer to original filing.	--
4	Cover Letters	<ul style="list-style-type: none"> • Letter from Ultratech for Certification Request • Letter from the Applicant to appoint Ultratech to act as an agent 	OK
5	Attestation Statements	--	--
6	ID Label/Location Info	FCC ID Label and Location Information	OK
7	Block Diagrams	Refer to original filing.	--
8	Schematic Diagrams	Refer to original filing.	--
9	Parts List/Tune Up Info	Refer to original filing.	--
10	Operational Description	Refer to original filing.	--
11	RF Exposure Info	MPE Evaluation, see section 6.6 in Test Report	OK
12	Users Manual	Refer to original filing and the amended page(s) for RF Exposure Information regarding minimum separation distance for this Class II Permissive Change	OK

EXHIBIT 2. INTRODUCTION

2.1. SCOPE

Reference:	FCC Part 15, Subpart C, Section 15.247:2001
Title:	Telecommunication – 47 Code of Federal Regulations (CFR), Part 15
Purpose of Test:	To gain FCC Certification Authorization for Frequency Hopping Spread Spectrum Transmitters Operating in the Frequency Band 902 - 928 MHz .
Test Procedures:	Both conducted and radiated emissions measurements were conducted in accordance with American National Standards Institute ANSI C63.4 - American National Standard for Methods of Measurement of Radio-Noise Emissions from Low-Voltage Electrical and Electronic Equipment in the Range of 9 kHz to 40 GHz.
Environmental Classification:	[] Residential [x] Light-industry, Commercial [x] Industry

2.2. RELATED SUBMITTAL(S)/GRANT(S)

None

2.3. NORMATIVE REFERENCES

Publication	Year	Title
47 CFR Parts 0-19	2000	Code of Federal Regulations – Telecommunication
ANSI C63.4	1992	American National Standard for Methods of Measurement of Radio-Noise Emissions from Low-Voltage Electrical and Electronic Equipment in the Range of 9 kHz to 40 GHz
CISPR 22 & EN 55022	1997 1998	Limits and Methods of Measurements of Radio Disturbance Characteristics of Information Technology Equipment
CISPR 16-1	1999	Specification for Radio Disturbance and Immunity measuring apparatus and methods
FCC Public Notice DA 00-705	2000	Filing and Measurement Guidelines for Frequency Hopping Spread Spectrum Systems
FCC Public Notice DA 00-1407	2000	Part 15 Unlicensed Modular Transmitter Approval

EXHIBIT 3. PERFORMANCE ASSESSMENT

3.1. CLIENT INFORMATION

APPLICANT	
Name:	Microwave Data Systems Inc.
Address:	175 Science Parkway Rochester, NY USA, 14620
Contact Person:	Mr. Dennis McCarthy Agency Compliance Engineer Phone #: 585 242-8440 Fax #: 585 241-5590 Email Address: dmccarthy@microwavedata.com

MANUFACTURER	
Name:	Microwave Data Systems Inc.
Address:	175 Science Parkway Rochester, NY USA, 14620
Contact Person:	Mr. Dennis McCarthy Agency Compliance Engineer Phone #: 585 242-8440 Fax #: 585 241-5590 Email Address: dmccarthy@microwavedata.com

3.2. EQUIPMENT UNDER TEST (EUT) INFORMATION

The following information (with the exception of the Date of Receipt) has been supplied by the applicant.

Brand Name:	Microwave Data Systems Inc.
Product Name:	TransNet
Model Name or Number:	EL805
Serial Number:	Test Sample
Type of Equipment:	Frequency Hopping Spread Spectrum Transmitters
Input Power Supply Type:	External Regulated DC Sources
Primary User Functions of EUT:	Wireless Data Transfer

3.3. EUT'S TECHNICAL SPECIFICATIONS

TRANSMITTER	
Equipment Type:	<input type="checkbox"/> Portable <input type="checkbox"/> Mobile <input checked="" type="checkbox"/> Base Station (fixed use)
Intended Operating Environment:	<input type="checkbox"/> Residential <input checked="" type="checkbox"/> Commercial, light industry & heavy industry
Power Supply Requirement:	13.8 Vdc nominal
RF Output Power Rating:	1 Watt (at antenna terminals)
Operating Frequency Range:	902.2 - 927.8 MHz
RF Output Impedance:	50 Ohm
Channel Spacing:	200 kHz
Duty Cycle:	Continuous
20 dB Bandwidth:	118.6 kHz
Modulation Type:	CPFSK
Channel Occupancy:	23 msec within 20 second period
Emission Designation:	Frequency Hopping Spread Spectrum
Oscillator Frequency(ies):	TCXO 16MHz, L.O. – 110.7MHz, 2 nd L.O. 100MHz
Antenna Connector Type:	Non-integral, Standard TNC connector (Professional Installation). Please refer to User Manual for detailed instruction of antenna installation and RF Exposure Warning.

3.4. LIST OF EUT'S PORTS

Port Number	EUT's Port Description	Number of Identical Ports	Connector Type	Cable Type (Shielded/Non-shielded)
1	LAN	1	RJ-45 Ethernet	Non-Shielded
2	COM	1	DB9 Female	Shielded
3	Antenna	1	TNC	Shielded
4	Power	1	2 Pin Inline	Non-Shielded

3.5. ANCILLARY EQUIPMENT

The EUT was tested while connected to the following representative configuration of ancillary equipment necessary to exercise the ports during tests:

Ancillary Equipment # 1	
Description:	Laptop
Brand:	Toshiba
Model Name or Number:	1605CDS/4.3
Serial Number:	1027387CU
Connected to EUT's Port:	COM1

3.6. ASSOCIATED ANTENNA SPECIFICATIONS

- (1) MDS ClearWave Antennas
 - Type: Yagi
 - P/N: 97-3662A13
 - Frequency Range: 890 – 960 MHz
 - In/Out Impedance: 50 Ohms
 - Gain: 4 dBd

(2)

900 MHz Omnis - MFB Series

An ISO-9001 Registered Company

BACK

900 MHz Omnidirectional Fiberglass Base Station Antenna Series

The MFB 900 MHz omnidirectional antennas are base matched, half wave antenna encapsulated in a heavy duty fiberglass radome with a thick walled aluminum mounting base for reliable long term use. All models are DC grounded.

General Specifications
900 MHz Fiberglass Omnidirectional Antenna Series

Radome Material:
.65" Pultruded white fiberglass

Polarization:
Vertical

Lightning Protection:
DC grounded

Nominal Impedance:
50 Ohms

Mounting Method:
(sold separately)
MMK1 light duty mast mount for antennas under 30" tall
MMK3 light duty mast mount for antennas over 30" tall
MMK4 heavy duty mast mount
MMK6 cast mount bracket
MBSWM wall mount bracket for antennas over 30" tall (two are required)

Mounting Base Diameter:
1 5/16"

Termination:
Unity and 3dB models- "N" Female
5dB and 7dB models- "N" male w/ 16" jumper
RPC w/ Reverse Polarity TNC

Features and Benefits:

- White ultra-violet resistant pultruded fiberglass radome. Protects the antenna from the elements.
- Thick walled aluminum mounting base. Helps prevent oscillation that could affect the quality of the transmission.
- Available in various gain configurations to fit various application requirements.



The MFB 900 MHz omnidirectional antennas are encapsulated in a heavy-duty fiberglass radome for reliable, long term performance under the toughest weather conditions.



MMK1 Mount



MMK3 Mount



MMK4 Mount



MMK6 Mount

Specifications

Electrical Specifications

Model #	Frequency Range	Factory Tuned Frequency	Gain	Bandwidth @ 1.5:1 VSWR	Vertical Beamwidth @ 1/2 Power	Maximum Power
MFB8960	896-940 MHz	898 MHz	Unity	40 MHz	75°	150 Watts
MFB9150	902-928 MHz	915 MHz	Unity	20 MHz	75°	150 Watts
MFB9300	928-932 MHz	930 MHz	Unity	5 MHz	75°	150 Watts
MFB9380	896-940 MHz	938 MHz	Unity	40 MHz	75°	150 Watts
MFB8963	896-940 MHz	898 MHz	3dB	30 MHz	40°	150 Watts
MFB9153	902-928 MHz	915 MHz	3dB	20 MHz	40°	150 Watts
MFB9303	928-932 MHz	930 MHz	3dB	5 MHz	40°	150 Watts
MFB9383	896-940 MHz	938 MHz	3dB	30 MHz	40°	150 Watts
MFB8965	896-940 MHz	898 MHz	5dB	20 MHz	22°	150 Watts
MFB9155	902-928 MHz	915 MHz	5dB	20 MHz	22°	150 Watts
MFB9305	928-932 MHz	930 MHz	5dB	5 MHz	22°	150 Watts
MFB9385	896-940 MHz	938 MHz	5dB	20 MHz	22°	150 Watts

Mechanical Specifications

Model #	Wind Survival	Lateral Thrust @ Rated Wind	Bending Moment @ Rated Wind	Height	Weight
MFB8960	100 mph	2.3 lbs	1.4 ft-lbs	14" (355.4 mm)	0.75 lbs (0.34 kg)
MFB9150	100 mph	2.3 lbs	1.4 ft-lbs	14" (355.4 mm)	0.75 lbs (0.34 kg)
MFB9300	100 mph	2.3 lbs	1.4 ft-lbs	14" (355.4 mm)	0.75 lbs (0.34 kg)
MFB9380	100 mph	2.3 lbs	1.4 ft-lbs	14" (355.4 mm)	0.75 lbs (0.34 kg)
MFB8963	100 mph	4.3 lbs	4.7 ft-lbs	26" (660.4 mm)	1.25 lbs (0.56 kg)
MFB9153	100 mph	4.3 lbs	4.7 ft-lbs	23" (590.5 mm)	1.25 lbs (0.56 kg)
MFB9303	100 mph	4.3 lbs	4.7 ft-lbs	26" (660.4 mm)	1.25 lbs (0.56 kg)
MFB9383	100 mph	4.3 lbs	4.7 ft-lbs	26" (660.4 mm)	1.25 lbs (0.56 kg)
MFB8965	100 mph	8.0 lbs	14.2 ft-lbs	48" (1219.2 mm)	1.75 lbs (0.79 kg)
MFB9155	100 mph	8.0 lbs	14.2 ft-lbs	48" (1219.2 mm)	1.75 lbs (0.79 kg)
MFB9305	100 mph	8.0 lbs	14.2 ft-lbs	48" (1219.2 mm)	1.75 lbs (0.79 kg)
MFB9385	100 mph	8.0 lbs	14.2 ft-lbs	48" (1219.2 mm)	1.75 lbs (0.79 kg)

EXHIBIT 4. EUT OPERATING CONDITIONS AND CONFIGURATIONS DURING TESTS

4.1. CLIMATE TEST CONDITIONS

The climate conditions of the test environment are as follows:

Temperature:	21°C
Humidity:	51%
Pressure:	102 kPa
Power Input Source:	13.8 Vdc nominal

4.2. OPERATIONAL TEST CONDITIONS & ARRANGEMENT FOR TESTS

Operating Modes:	<ul style="list-style-type: none"> ▪ Each of lowest, middle and highest channel frequencies transmits continuously for emissions measurements. ▪ The EUT operates in normal Frequency Hopping mode for occupancy duration, and frequency separation.
Special Test Software & Hardware:	Special firmware and hardware provided by the Applicant are installed to allow the EUT to operate in hopping mode or at each channel frequency continuously. For example, the transmitter will be operated at each of lowest, middle and highest frequencies individually continuously during testing.
Transmitter Test Antenna:	The EUT is tested with the antenna fitted in a manner typical of normal intended use as non-integral antenna equipment.

Transmitter Test Signals	
Frequency Band(s):	902.2 - 927.8 MHz
Frequency(ies) Tested:	Lowest: 902.2 MHz Middle: 915.0 MHz Highest: 927.8 MHz
RF Power Output (measured maximum output power):	30 dBm, 1Watt (at antenna terminals)
Normal Test Modulation:	CPFSK
Modulating Signal Source:	Internal

NOTE: The TransNet, model EL805 was tested with the highest gain antenna (model#: MFB9155) to represent the worst-case test configuration of the Maxrad 900 MHz Omnis-MFB Antenna Series and MDS ClearWave Yagi Antenna, see section 3.6 of this Test Report for details.

EXHIBIT 5. SUMMARY OF TEST RESULTS

5.1. LOCATION OF TESTS

All of the measurements described in this report were performed at Ultratech Group of Labs located in the city of Oakville, Province of Ontario, Canada.

Radiated Emissions were performed at the Ultratech's 3 Meter Open Field Test Site (OFTS) situated in the Town of Oakville, province of Ontario.

The above site have been calibrated in accordance with ANSI C63.4, and found to be in compliance with the requirements of Sec. 2.948 of the FCC Rules. The descriptions and site measurement data of the Oakville Open Field Test Site has been filed with FCC office (FCC File No.: 31040/SIT 1300B3) and Industry Canada office (Industry Canada File No.: IC2049). Last Date of Site Calibration: August 10, 2002.

5.2. APPLICABILITY & SUMMARY OF EMC EMISSION TEST RESULTS

FCC Paragraph	Test Requirements	Compliance (Yes/No)
Public Notice DA 00-1407	Part 15 Unlicensed Modular Transmitter Approval	N/A
15.107(a)	AC Power Line Conducted Emissions Measurements (Transmit & Receive)	N/A
15.247(a)(1) & 15.247(a)(1)(i)	Frequency Hopping Systems Characteristics	N/A
15.247(b)(2)	Peak Output Power	Yes
15.247(b)(4), 1.1307, 1.1310, 2.1091 & 2.1093	RF Exposure Limit	Yes
15.247(c)	Band-Edge and RF Conducted Spurious Emissions at the Transmitter Antenna Terminal	N/A
15.247(c), 15.209 & 15.205	Transmitter Radiated Emissions	Yes

5.3. MODIFICATIONS INCORPORATED IN THE EUT FOR COMPLIANCE PURPOSES

- 1) The EL805 PCB had it's internal RF ground plane isolated from the general DC gnd power traces that fed DC power to the final stage RF amplifier, this in turn isolated the source of harmonic radiation from the amplifier to the PCB case ground and thus significantly reduced the harmonic radiation.
- 2) A 0603 low value capacitor was added near the antenna connector that already had a set of pads on the PCB. The capacitor was 2.2pf and this rolled off the higher limit harmonics at the antenna port. The PCB did not change for this.

EXHIBIT 6. MEASUREMENTS, EXAMINATIONS & TEST DATA FOR EMC EMISSIONS

6.1. TEST PROCEDURES

This section contains test results only. Details of test methods and procedures can be found in Exhibit 8 of this report, ANSI C63-4:1992 and FCC Public Notice @ DA 00-705 (March 30, 2000) – Filing and Measurement Guidelines for Frequency Hopping Spread Spectrum Systems.

6.2. MEASUREMENT UNCERTAINTIES

The measurement uncertainties stated were calculated in accordance with requirements of UKAS Document NIS 81 with a confidence level of 95%. Please refer to Exhibit 7 for Measurement Uncertainties.

6.3. MEASUREMENT EQUIPMENT USED

The measurement equipment used complied with the requirements of the Standards referenced in the Methods & Procedures ANSI C64-3:1992, FCC 15.247 and CISPR 16-1.

6.4. ESSENTIAL/PRIMARY FUNCTIONS AS DECLARED BY THE MANUFACTURER

The essential function of the EUT is to correctly communicate data to and from radios over RF link.

6.5. PEAK OUTPUT POWER & EQUIVALENT ISOTROPIC RADIATED POWER (EIRP) [47 CFR § 15.247(b)]

6.5.1. Limits

- **47 CFR 15.247(b)(2):** 1 watt for systems employing at least 50 hopping channels; and, 0.25 watts for systems employing less than 50 hopping channels, but at least 25 hopping channels
- **47 CFR 15.247(b)(3):** If the antennas of directional gain greater than 6 dBi are used, the peak power from the intentional radiator shall be reduced below, as appropriate, by the amount in dB that the directional gain of the antenna exceeds 6 dBi.

6.5.2. Method of Measurements

Refer to Exhibit 8, Section 8.2 of this test report, 47 CFR 15.247(b)(2)&(3), and ANSI C63-4:1992

6.5.3. Test Arrangement

Conducted Output Power at Antenna Terminals

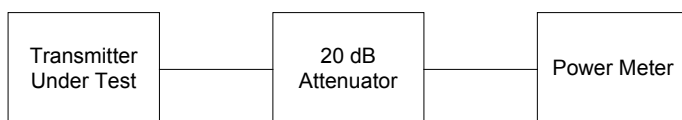

6.5.4. Test Equipment List

Test Instruments	Manufacturer	Model No.	Serial No.	Frequency Range
Power Meter	Hewlett Packard	436A	1725A02249	10 kHz – 50 GHz, sensor dependent
Power Sensor	Hewlett Packard	8481A	2702A68983	10 MHz – 18 GHz
Attenuator	Weinschel Corp	24-20-34	BJ2357	DC – 8.5 GHz
Spectrum Analyzer/ EMI Receiver	Advantest	R3271	15050203	100 Hz – 26.5 GHz
Dipole Antenna	EMCO	3121C	8907-440	30 MHz – 1 GHz
Dipole Antenna	EMCO	3121C	8907-434	30 MHz – 1 GHz
Synthesized Sweeper	Hewlett Packard	83752B	3610A00457	0.01 – 20 GHz

6.5.5. Test Data

Peak Power Measurements

For systems employing at least 50 hopping channels:

Transmitter Channel	Frequency (MHz)	Peak Power at Antenna Terminal (dBm)	Peak Power with Cable Loss (dBm)	Limit (dBm)
Lowest	902.20	30.0	29.0	30.0
Middle	915.00	29.7	28.6	30.0
Highest	927.80	29.4	28.2	30.0

Antenna and Cable Required to Comply with EIRP Limit

Antenna Gain (dBd)	Antenna Gain (dBi)	Minimum Cable Loss (dB)	Peak Power at Antenna Terminal (dBm)	Calculated EIRP (dBm)	EIRP Limit (dBm)
Unity	2.15	1.0	30.0	31.2	36.0
3	5.15	1.0	30.0	34.2	36.0
5	7.15	1.2	30.0	36.0	36.0

NOTE: The Peak Power measured at the end of antenna feedline (in dBm) plus the antenna gain (in dBi) shall not be greater than 36 dBm. Refer to the amended user's manual page(s) for the manufacturer recommended Antenna and Feedline selection requirements for maintaining compliance with FCC EIRP limit.

6.6. RF EXPOSURE REQUIRMENTS [47 CFR §§ 15.247(b)(4), 1.1310 & 2.1091]

6.6.1. Limits

- **FCC 15.247(b)(4):** Systems operating under provisions of this section shall be operated in a manner that ensures that the public is not exposed to radio frequency energy levels in excess of the Commission’s guidelines. See @ 1.1307(b)(1).
- **FCC 1.1310:-** The criteria listed in the following table shall be used to evaluate the environmental impact of human exposure to radio-frequency (RF) radiation as specified in 1.1307(b).

TABLE 1—LIMITS FOR MAXIMUM PERMISSIBLE EXPOSURE (MPE)

Frequency range (MHz)	Electric field strength (V/m)	Magnetic field strength (A/m)	Power density (mW/cm ²)	Averaging time (minutes)
(A) Limits for Occupational/Controlled Exposures				
0.3–3.0	614	1.63	*(100)	6
3.0–30	1842/f	4.89/f	*(900/f ²)	6
30–300	61.4	0.163	1.0	6
300–1500	f/300	6
1500–100,000	5	6
(B) Limits for General Population/Uncontrolled Exposure				
0.3–1.34	614	1.63	*(100)	30
1.34–30	824/f	2.19/f	*(180/f ²)	30
30–300	27.5	0.073	0.2	30
300–1500	f/1500	30
1500–100,000	1.0	30

f = frequency in MHz

* = Plane-wave equivalent power density

NOTE 1 TO TABLE 1: Occupational/controlled limits apply in situations in which persons are exposed as a consequence of their employment provided those persons are fully aware of the potential for exposure and can exercise control over their exposure. Limits for occupational/controlled exposure also apply in situations when an individual is transient through a location where occupational/controlled limits apply provided he or she is made aware of the potential for exposure.

NOTE 2 TO TABLE 1: General population/uncontrolled exposures apply in situations in which the general public may be exposed, or in which persons that are exposed as a consequence of their employment may not be fully aware of the potential for exposure or can not exercise control over their exposure.

6.6.2. Method of Measurements

Refer to FCC @ 1.1310, 2.1091 and Public Notice DA 00-705 (March 30, 2000)

- Spread spectrum transmitters operating under section 15.247 are categorically from routine environmental evaluation to demonstrating RF exposure compliance with respect to MPE and/or SAR limits. These devices are not exempted from compliance (As indicated in Section 15.247(b)(4), these transmitters are required to operate in a manner that ensures that exposure to public users and nearby persons) does not exceed the Commission’s RF exposure guidelines (see Section 1.1307 and 2.1093). Unless a device operates at substantially low power levels, with a low gain antenna(s), supporting information is generally needed to establish the various potential operating configurations and exposure conditions of a transmitter and its antenna(s) in order to determine compliance with the RF exposure guidelines.
- In order to demonstrate compliance with MPE requirements (see Section 2.1091), the following information is typically needed:
 - (1) Calculation that estimates the minimum separation distance (20 cm or more) between an antenna and persons required to satisfy power density limits defined for free space.
 - (2) Antenna installation and device operating instructions for installers (professional/unskilled users), and the parties responsible for ensuring compliance with the RF exposure requirement
 - (3) Any caution statements and/or warning labels that are necessary in order to comply with the exposure limits
 - (4) Any other RF exposure related issues that may affect MPE compliance

Calculation Method of RF Safety Distance:

$$S = PG/4\pi r^2 = EIRP/4\pi r^2$$

Where: P: power input to the antenna in mW
EIRP: Equivalent (effective) isotropic radiated power
S: power density mW/cm²
G: numeric gain of antenna relative to isotropic radiator
r: distance to centre of radiation in cm

$$r = \sqrt{EIRP/4\pi S}$$

FCC radio frequency exposure limits may not be exceeded at distances closer than r cm from the antenna of this device

- For portable transmitters (see Section 2.1093), or devices designed to operate next to a person's body, compliance is determined with respect to the SAR limit (define in the body tissues) for near-field exposure conditions. If the maximum average output power, operating condition configurations and exposure conditions are comparable to those of existing cellular and PCS phones., an SAR evaluation may be required in order to determine if such a device complies with SAR limit. When SAR evaluation data is not available, and the additional supporting information cannot assure compliance, the Commission may request that an SAR evaluation be performed, as provided for in Section 1.1307(d)

6.6.3. Test Data

The minimum separation distance between the antenna and bodies of users are calculated using the following formula:

RF EXPOSURE DISTANCE LIMITS: $r = (PG/4\pi S)^{1/2} = (EIRP/4\pi S)^{1/2}$

$S = 902/1500 \text{ mW/cm}^2$

$EIRP = 4000 \text{ mW max.}$

$r = (EIRP/4\pi S)^{1/2} = (4000/4\pi(902/1500))^{1/2} = 23 \text{ cm}$

Therefore, the minimum separation distance from users is 23 cm when used with the antenna(s) specified in this test report.

Evaluation of RF Exposure Compliance Requirements	
RF Exposure Requirements	Compliance with FCC Rules
Minimum calculated separation distance between antenna and persons required: 23 cm	Manufacturer's instruction for separation distance between antenna and persons required: 23 cm.
Antenna installation and device operating instructions for installers (professional/unskilled users), and the parties responsible for ensuring compliance with the RF exposure requirement	The end product in final installation will be maintained, such that full compliance are always ensured by the manufacturer (Microwave Data Systems Inc.)
Caution statements and/or warning labels that are necessary in order to comply with the exposure limits	Please refer to the amended User Manual page(s) for RF Exposure Information.
Any other RF exposure related issues that may affect MPE compliance	None.

6.7. TRANSMITTER SPURIOUS RADIATED EMISSIONS AT 3 METERS [47 CFR §§ 15.247(c), 15.209 & 15.205]

6.7.1. Limits

In any 100 KHz bandwidth outside the operating frequency band, the radio frequency power that is produced by modulation products of the spreading sequence, the information sequence and the carrier frequency shall be either at least 20 dB below that in any 100 KHz bandwidth within the band that contains the highest level of the desired power or shall not exceed the general levels specified in section 15.209(a), which lesser attenuation.

All other emissions inside restricted bands specified in section 15.205(a) shall not exceed the general radiated emission limits specified in section 15.209(a)

Remarks:

- Applies to harmonics/spurious emissions that fall in the restricted bands listed in section 15.205. The maximum permitted average field strength is listed in section 15.209.
- **47 CFR § 15.237(c):** The emission limits as specified above are based on measurement instrument employing an average detector. The provisions in section 15.35 for limiting peak emissions apply.

FCC CFR 47, Part 15, Subpart C, Para. 15.205(a) - Restricted Frequency Bands

MHz	MHz	MHz	GHz
0.090-0.110	16.42-16.423	399.9-410	4.5-5.15
¹ 0.495-0.505	16.69475-16.69525	608-614	5.35-5.46
2.1735-2.1905	16.80425-16.80475	960-1240	7.25-7.75
4.125-4.128	25.5-25.67	1300-1427	8.025-8.5
4.17725-4.17775	37.5-38.25	1435-1626.5	9.0-9.2
4.20725-4.20775	73-74.6	1645.5-1646.5	9.3-9.5
6.215-6.218	74.8-75.2	1660-1710	10.6-12.7
6.26775-6.26825	108-121.94	1718.8-1722.2	13.25-13.4
6.31175-6.31225	123-138	2200-2300	14.47-14.5
8.291-8.294	149.9-150.05	2310-2390	15.35-16.2
8.362-8.366	156.52475-156.52525	2483.5-2500	17.7-21.4
8.37625-8.38675	156.7-156.9	2655-2900	22.01-23.12
8.41425-8.41475	162.0125-167.17	3260-3267	23.6-24.0
12.29-12.293	167.72-173.2	3332-3339	31.2-31.8
12.51975-12.52025	240-285	3345.8-3358	36.43-36.5
12.57675-12.57725	322-335.4	3600-4400	(²)
13.36-13.41.			

¹ Until February 1, 1999, this restricted band shall be 0.490-0.510 MHz.

² Above 38.6

47 CFR § 15.209(a)

-- Field Strength Limits within Restricted Frequency Bands --

Frequency (MHz)	Field Strength (microvolts/meter)	Measurement Distance (meters)
0.009 - 0.490	2,400 / F (kHz)	300
0.490 - 1.705	24,000 / F (kHz)	30
1.705 - 30.0	30	30
30 - 88	100	3
88 - 216	150	3
216 - 960	200	3
Above 960	500	3

6.7.2. Method of Measurements

Refer to Exhibit 8, Section 8.3 of this test report and ANSI 63.4-1992, Para. 8 for detailed radiated emissions measurement procedures.

The following measurement procedures were also applied:

- Applies to harmonics/spurious that fall in the restricted bands listed in Section 15.205. the maximum permitted average field strength is listed in Section 15.209. A Pre-Amp and highpass filter are used for this measurement.
- For measurement below 1 GHz, set RBW = 100 KHz, VBW \geq 100 KHz, SWEEP=AUTO.
- For measurement above 1 GHz, set RBW = 1 MHz, VBW = 1 MHz (Peak) & VBW = 10 Hz (Average), SWEEP=AUTO.
- If the emission is pulsed, modified the unit for continuous operation, then use the settings above for measurements, then correct the reading by subtracting the peak-average correction factor derived from the appropriate duty cycle calculation. See Section 15.35(b) and (c).

6.7.3. Test Arrangement

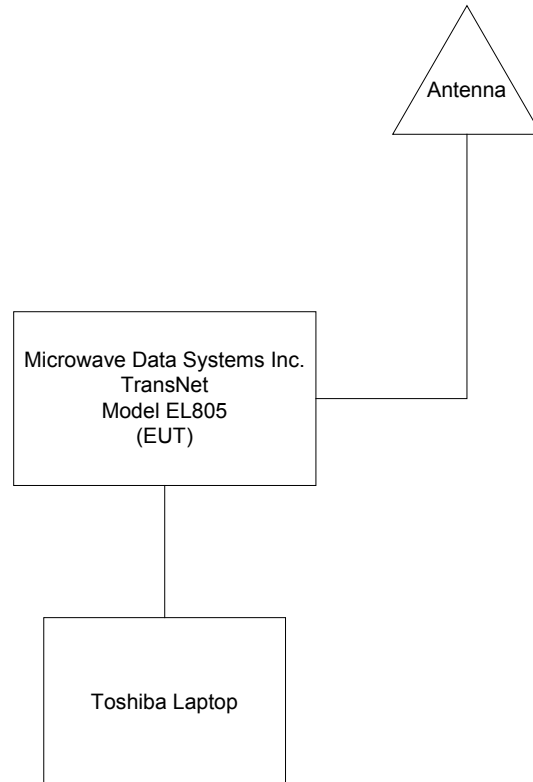

6.7.4. Test Equipment List

Test Instruments	Manufacturer	Model No.	Serial No.	Frequency Range
Spectrum Analyzer/ EMI Receiver	Advantest	R3271	15050203	100 Hz – 26.5 GHz
Microwave Amplifier	Hewlett Packard	8449B	3008A00769	1 GHz to 26.5 GHz
Biconilog Antenna	EMCO	3143	1029	20 MHz to 2 GHz
Horn Antenna	EMCO	3155	9701-5061	1 GHz – 18 GHz

6.7.5. Test Data

Remarks:

- (1) The TransNet, model EL805 was tested with the highest gain antenna (model#: MFB9155) to represent the worst-case test configuration of the Maxrad 900 MHz Omnis-MFB Antenna Series and MDS ClearWave Yagi Antenna, see section 3.6 of this Test Report for details.
- (2) Radiated emission tests were performed in two different enclosure/case (metallic and plastic) and each enclosure with Maxrad 900 MHz Omnis-MFB Antenna and MDS ClearWave Yagi Antenna:

- Test Configurations:
1. Metallic enclosure with Maxrad 900 MHz Omnis-MFB Antenna;
 2. Metallic enclosure with MDS ClearWave Yagi Antenna;
 3. Plastic enclosure with Maxrad 900 MHz Omnis-MFB Antenna;
 4. Plastic enclosure with MDS ClearWave Yagi Antenna

The following test results are the worst-case measurements

6.7.5.1. Configuration 1: Metallic Enclosure with Maxrad 900 MHz Omnis-MFB Antenna

Lowest Frequency (902.2 MHz)

Frequency (MHz)	RF Peak Level (dBµV/m)	RF Avg Level (dBµV/m)	Antenna Plane (H/V)	Limit 15.209 (dBµV/m)	Limit 15.247 (dBµV/m)	Margin (dB)	Pass/Fail
902.2	135.84	--	V	--	--	--	--
902.2	135.56	--	H	--	--	--	--
2706.6	49.56	45.81	V	54.0	115.8	-8.2	Pass*
2706.6	50.19	46.98	H	54.0	115.8	-7.0	Pass*
3608.8	46.19	36.50	V	54.0	115.8	-17.5	Pass*
3608.8	44.72	38.78	H	54.0	115.8	-15.2	Pass*
4511.0	46.66	36.06	V	54.0	115.8	-17.9	Pass*
4511.0	48.09	38.72	H	54.0	115.8	-15.3	Pass*
5413.2	50.88	44.75	V	54.0	115.8	-9.3	Pass*
5413.2	51.19	44.63	H	54.0	115.8	-9.4	Pass*
8119.8	54.19	46.81	V	54.0	115.8	-7.2	Pass*

The emissions were scanned from 10 MHz to 10 GHz and all emissions within 20 dB below the limits were recorded.

* Frequency in restricted bands, therefore FCC 15.209 limit applied.

Middle Frequency (915.0 MHz)

Frequency (MHz)	RF Peak Level (dBµV/m)	RF Avg Level (dBµV/m)	Antenna Plane (H/V)	Limit 15.209 (dBµV/m)	Limit 15.247 (dBµV/m)	Margin (dB)	Pass/Fail
915.0	135.47	--	V	--	--	--	--
915.0	130.75	--	H	--	--	--	--
2745.0	48.00	43.63	V	54.0	115.5	-10.4	Pass*
2745.0	45.75	40.34	H	54.0	115.5	-13.7	Pass*
3660.0	45.88	35.47	H	54.0	115.5	-18.5	Pass*
4575.0	47.47	39.84	V	54.0	115.5	-14.2	Pass*
4575.0	47.34	39.69	H	54.0	115.5	-14.3	Pass*
7320.0	49.41	38.16	V	54.0	115.5	-15.8	Pass*
7320.0	49.94	38.47	H	54.0	115.5	-15.5	Pass*
8235.0	54.53	46.78	V	54.0	115.5	-7.2	Pass*
8235.0	51.81	41.59	H	54.0	115.5	-12.4	Pass*

The emissions were scanned from 10 MHz to 10 GHz and all emissions within 20 dB below the limits were recorded.

* Frequency in restricted bands, therefore FCC 15.209 limit applied.

Highest Frequency (927.8 MHz)

Frequency (MHz)	RF Peak Level (dBµV/m)	RF Avg Level (dBµV/m)	Antenna Plane (H/V)	Limit 15.209 (dBµV/m)	Limit 15.247 (dBµV/m)	Margin (dB)	Pass/Fail
927.8	132.19	--	V	--	--	--	--
927.8	126.88	--	H	--	--	--	--
2783.4	48.50	44.56	V	54.0	112.2	-9.4	Pass*
2783.4	45.88	37.25	H	54.0	112.2	-16.8	Pass*
3711.2	46.09	35.66	V	54.0	112.2	-18.3	Pass*
3711.2	45.31	34.66	H	54.0	112.2	-19.3	Pass*
4639.0	49.28	41.84	V	54.0	112.2	-12.2	Pass*
4639.0	50.84	46.34	H	54.0	112.2	-7.7	Pass*
7422.4	52.03	42.41	V	54.0	112.2	-11.6	Pass*
7422.4	48.78	38.25	H	54.0	112.2	-15.8	Pass*
8350.2	49.97	36.41	V	54.0	112.2	-17.6	Pass*

The emissions were scanned from 10 MHz to 10 GHz and all emissions within 20 dB below the limits were recorded.

* Frequency in restricted bands, therefore FCC 15.209 limit applied.

6.7.5.2. Configuration 2: Metallic Enclosure with MDS ClearWave Yagi Antenna

Lowest Frequency (902.2 MHz)

Frequency (MHz)	RF Peak Level (dBµV/m)	RF Avg Level (dBµV/m)	Antenna Plane (H/V)	Limit 15.209 (dBµV/m)	Limit 15.247 (dBµV/m)	Margin (dB)	Pass/Fail
902.2	133.28	--	V	--	--	--	--
902.2	136.28	--	H	--	--	--	--
2706.6	51.78	48.84	V	54.0	116.3	-5.2	Pass*
2706.6	53.72	51.06	H	54.0	116.3	-2.9	Pass*
3608.8	45.97	35.63	V	54.0	116.3	-18.4	Pass*
3608.8	48.97	38.13	H	54.0	116.3	-15.9	Pass*
4511.0	46.81	35.72	V	54.0	116.3	-18.3	Pass*
4511.0	52.00	44.09	H	54.0	116.3	-9.9	Pass*
5413.2	54.03	50.53	V	54.0	116.3	-3.5	Pass*
5413.2	52.81	48.13	H	54.0	116.3	-5.9	Pass*
8119.8	55.34	48.72	V	54.0	116.3	-5.3	Pass*
8119.8	55.44	47.72	H	54.0	116.3	-6.3	Pass*

The emissions were scanned from 10 MHz to 10 GHz and all emissions within 20 dB below the limits were recorded.

* Frequency in restricted bands, therefore FCC 15.209 limit applied.

Middle Frequency (915.0 MHz)

Frequency (MHz)	RF Peak Level (dBµV/m)	RF Avg Level (dBµV/m)	Antenna Plane (H/V)	Limit 15.209 (dBµV/m)	Limit 15.247 (dBµV/m)	Margin (dB)	Pass/Fail
915.0	132.09	--	V	--	--	--	--
915.0	130.56	--	H	--	--	--	--
2745.0	47.09	40.19	V	54.0	112.1	-13.8	Pass*
2745.0	49.41	44.16	H	54.0	112.1	-9.8	Pass*
3660.0	48.44	40.03	H	54.0	112.1	-14.0	Pass*
4575.0	49.06	42.50	V	54.0	112.1	-11.5	Pass*
4575.0	53.66	48.91	H	54.0	112.1	-5.1	Pass*
7320.0	50.56	39.38	V	54.0	112.1	-14.6	Pass*
7320.0	53.16	44.22	H	54.0	112.1	-9.8	Pass*
8235.0	54.53	47.59	V	54.0	112.1	-6.4	Pass*
8235.0	53.25	42.00	H	54.0	112.1	-12.0	Pass*

The emissions were scanned from 10 MHz to 10 GHz and all emissions within 20 dB below the limits were recorded.

* Frequency in restricted bands, therefore FCC 15.209 limit applied.

Highest Frequency (927.8 MHz)

Frequency (MHz)	RF Peak Level (dBµV/m)	RF Avg Level (dBµV/m)	Antenna Plane (H/V)	Limit 15.209 (dBµV/m)	Limit 15.247 (dBµV/m)	Margin (dB)	Pass/Fail
927.8	131.41	--	V	--	--	--	--
927.8	133.88	--	H	--	--	--	--
2783.4	46.72	40.09	V	54.0	113.9	-13.9	Pass*
2783.4	46.16	39.53	H	54.0	113.9	-14.5	Pass*
3711.2	45.91	34.06	H	54.0	113.9	-19.9	Pass*
4639.0	48.00	38.92	V	54.0	113.9	-15.1	Pass*
4639.0	52.46	47.28	H	54.0	113.9	-6.7	Pass*
7422.4	49.81	39.78	V	54.0	113.9	-14.2	Pass*
7422.4	52.16	43.66	H	54.0	113.9	-10.3	Pass*
8350.2	54.19	45.53	V	54.0	113.9	-8.5	Pass*
8350.2	55.47	46.69	H	54.0	113.9	-7.3	Pass*

The emissions were scanned from 10 MHz to 10 GHz and all emissions within 20 dB below the limits were recorded.

* Frequency in restricted bands, therefore FCC 15.209 limit applied.

6.7.5.3. Configuration 3: Plastic Enclosure with Maxrad 900 MHz Omnis-MFB Antenna

Lowest Frequency (902.2 MHz)

Frequency (MHz)	RF Peak Level (dBµV/m)	RF Avg Level (dBµV/m)	Antenna Plane (H/V)	Limit 15.209 (dBµV/m)	Limit 15.247 (dBµV/m)	Margin (dB)	Pass/Fail
902.2	133.00	--	V	--	--	--	--
902.2	133.56	--	H	--	--	--	--
2706.6	52.59	49.25	V	54.0	113.6	-4.8	Pass*
2706.6	51.13	47.06	H	54.0	113.6	-6.9	Pass*
3608.8	47.47	40.63	V	54.0	113.6	-13.4	Pass*
3608.8	48.50	41.23	H	54.0	113.6	-12.8	Pass*
4511.0	49.09	42.44	V	54.0	113.6	-11.6	Pass*
4511.0	50.84	42.53	H	54.0	113.6	-11.5	Pass*
5413.2	50.63	43.88	V	54.0	113.6	-10.1	Pass*
5413.2	51.59	45.28	H	54.0	113.6	-8.7	Pass*
8119.8	58.91	53.48	V	54.0	113.6	-0.5	Pass*
8119.8	54.16	43.43	H	54.0	113.6	-10.6	Pass*
9022.0	56.94	47.28	V	54.0	113.6	-6.7	Pass*

The emissions were scanned from 10 MHz to 10 GHz and all emissions within 20 dB below the limits were recorded.

* Frequency in restricted bands, therefore FCC 15.209 limit applied.

Middle Frequency (915.0 MHz)

Frequency (MHz)	RF Peak Level (dBµV/m)	RF Avg Level (dBµV/m)	Antenna Plane (H/V)	Limit 15.209 (dBµV/m)	Limit 15.247 (dBµV/m)	Margin (dB)	Pass/Fail
915.0	135.19	--	V	--	--	--	--
915.0	131.69	--	H	--	--	--	--
2745.0	51.03	47.63	V	54.0	115.2	-6.4	Pass*
2745.0	48.28	41.53	H	54.0	115.2	-12.5	Pass*
3660.0	48.16	41.50	V	54.0	115.2	-12.5	Pass*
3660.0	48.28	38.59	H	54.0	115.2	-15.4	Pass*
4575.0	48.56	43.31	V	54.0	115.2	-10.7	Pass*
4575.0	49.69	40.13	H	54.0	115.2	-13.9	Pass*
7320.0	52.75	45.94	V	54.0	115.2	-8.1	Pass*
7320.0	52.47	40.97	H	54.0	115.2	-13.0	Pass*
8235.0	58.91	53.63	V	54.0	115.2	-0.4	Pass*
8235.0	56.63	48.63	H	54.0	115.2	-5.4	Pass*
9150.0	58.84	50.80	V	54.0	115.2	-3.2	Pass*

The emissions were scanned from 10 MHz to 10 GHz and all emissions within 20 dB below the limits were recorded.

* Frequency in restricted bands, therefore FCC 15.209 limit applied.

Highest Frequency (927.8 MHz)

Frequency (MHz)	RF Peak Level (dBµV/m)	RF Avg Level (dBµV/m)	Antenna Plane (H/V)	Limit 15.209 (dBµV/m)	Limit 15.247 (dBµV/m)	Margin (dB)	Pass/Fail
927.8	132.94	--	V	--	--	--	--
927.8	124.56	--	H	--	--	--	--
2783.4	48.34	42.22	V	54.0	112.9	-11.8	Pass*
2783.4	47.16	41.06	H	54.0	112.9	-12.9	Pass*
3711.2	46.09	37.50	V	54.0	112.9	-16.5	Pass*
3711.2	47.47	35.84	H	54.0	112.9	-18.2	Pass*
4639.0	55.00	50.75	V	54.0	112.9	-3.3	Pass*
4639.0	51.28	44.84	H	54.0	112.9	-9.2	Pass*
7422.4	56.48	50.81	V	54.0	112.9	-3.2	Pass*
7422.4	52.94	42.75	H	54.0	112.9	-11.3	Pass*
8350.2	53.31	44.56	V	54.0	112.9	-9.4	Pass*
8350.2	53.78	42.19	H	54.0	112.9	-11.8	Pass*

The emissions were scanned from 10 MHz to 10 GHz and all emissions within 20 dB below the limits were recorded.

* Frequency in restricted bands, therefore FCC 15.209 limit applied.

6.7.5.4. Configuration 4: Plastic Enclosure with MDS ClearWave Yagi Antenna

Lowest Frequency (902.2 MHz)

Frequency (MHz)	RF Peak Level (dBµV/m)	RF Avg Level (dBµV/m)	Antenna Plane (H/V)	Limit 15.209 (dBµV/m)	Limit 15.247 (dBµV/m)	Margin (dB)	Pass/Fail
902.2	134.22	--	V	--	--	--	--
902.2	136.22	--	H	--	--	--	--
2706.6	51.59	48.16	V	54.0	116.2	-5.8	Pass*
2706.6	52.53	49.94	H	54.0	116.2	-4.1	Pass*
3608.8	46.19	34.34	V	54.0	116.2	-19.7	Pass*
4511.0	48.53	40.97	V	54.0	116.2	-13.0	Pass*
4511.0	49.56	43.63	H	54.0	116.2	-10.4	Pass*
5413.2	50.81	45.16	V	54.0	116.2	-8.8	Pass*
5413.2	50.28	44.69	H	54.0	116.2	-9.3	Pass*
8119.8	58.06	52.58	V	54.0	116.2	-1.4	Pass*
8119.8	55.56	49.63	H	54.0	116.2	-4.4	Pass*
9022.0	55.72	48.03	V	54.0	116.2	-6.0	Pass*
9022.0	54.69	43.22	H	54.0	116.2	-10.8	Pass*

The emissions were scanned from 10 MHz to 10 GHz and all emissions within 20 dB below the limits were recorded.

* Frequency in restricted bands, therefore FCC 15.209 limit applied.

Middle Frequency (915.0 MHz)

Frequency (MHz)	RF Peak Level (dBµV/m)	RF Avg Level (dBµV/m)	Antenna Plane (H/V)	Limit 15.209 (dBµV/m)	Limit 15.247 (dBµV/m)	Margin (dB)	Pass/Fail
915.0	131.81	--	V	--	--	--	--
915.0	133.53	--	H	--	--	--	--
2745.0	46.69	42.00	V	54.0	113.5	-12.0	Pass*
2745.0	49.34	45.41	H	54.0	113.5	-8.6	Pass*
3660.0	47.63	38.91	V	54.0	113.5	-15.1	Pass*
3660.0	46.94	38.44	H	54.0	113.5	-15.6	Pass*
4575.0	50.88	44.69	V	54.0	113.5	-9.3	Pass*
4575.0	51.91	47.88	H	54.0	113.5	-6.1	Pass*
7320.0	53.06	47.03	V	54.0	113.5	-7.0	Pass*
7320.0	52.38	46.13	H	54.0	113.5	-7.9	Pass*
8235.0	55.53	50.46	V	54.0	113.5	-3.5	Pass*
8235.0	53.13	45.13	H	54.0	113.5	-8.9	Pass*
9150.0	53.91	41.75	V	54.0	113.5	-12.3	Pass*

The emissions were scanned from 10 MHz to 10 GHz and all emissions within 20 dB below the limits were recorded.

* Frequency in restricted bands, therefore FCC 15.209 limit applied.

Highest Frequency (927.8 MHz)

Frequency (MHz)	RF Peak Level (dBµV/m)	RF Avg Level (dBµV/m)	Antenna Plane (H/V)	Limit 15.209 (dBµV/m)	Limit 15.247 (dBµV/m)	Margin (dB)	Pass/Fail
927.8	129.84	--	V	--	--	--	--
927.8	133.16	--	H	--	--	--	--
2783.4	45.53	39.09	V	54.0	113.2	-14.9	Pass*
2783.4	48.31	41.78	H	54.0	113.2	-12.2	Pass*
3711.2	46.88	38.22	V	54.0	113.2	-15.8	Pass*
4639.0	50.40	44.53	V	54.0	113.2	-9.5	Pass*
4639.0	52.91	48.66	H	54.0	113.2	-5.3	Pass*
7422.4	54.91	49.25	V	54.0	113.2	-4.8	Pass*
7422.4	52.34	45.34	H	54.0	113.2	-8.7	Pass*
8350.2	55.31	47.06	V	54.0	113.2	-6.9	Pass*
8350.2	56.47	50.50	H	54.0	113.2	-3.5	Pass*

The emissions were scanned from 10 MHz to 10 GHz and all emissions within 20 dB below the limits were recorded.

* Frequency in restricted bands, therefore FCC 15.209 limit applied.

EXHIBIT 7. MEASUREMENT UNCERTAINTY

The measurement uncertainties stated were calculated in accordance with the requirements of NIST Technical Note 1297 and NIS 81 (1994)

7.1. RADIATED EMISSION MEASUREMENT UNCERTAINTY

CONTRIBUTION (Radiated Emissions)	PROBABILITY DISTRIBUTION	UNCERTAINTY (+ dB)	
		3 m	10 m
Antenna Factor Calibration	Normal (k=2)	± 1.0	± 1.0
Cable Loss Calibration	Normal (k=2)	± 0.3	± 0.5
EMI Receiver specification	Rectangular	± 1.5	± 1.5
Antenna Directivity	Rectangular	+0.5	+0.5
Antenna factor variation with height	Rectangular	± 2.0	± 0.5
Antenna phase center variation	Rectangular	0.0	± 0.2
Antenna factor frequency interpolation	Rectangular	± 0.25	± 0.25
Measurement distance variation	Rectangular	± 0.6	± 0.4
Site imperfections	Rectangular	± 2.0	± 2.0
Mismatch: Receiver VRC $\Gamma_1 = 0.2$ Antenna VRC $\Gamma_R = 0.67(\text{Bi}) 0.3 (\text{Lp})$ Uncertainty limits $20\text{Log}(1 \pm \Gamma_1 \Gamma_R)$	U-Shaped	+1.1 -1.25	± 0.5
System repeatability	Std. Deviation	± 0.5	± 0.5
Repeatability of EUT		-	-
Combined standard uncertainty	Normal	+2.19 / -2.21	+1.74 / -1.72
Expanded uncertainty U	Normal (k=2)	+4.38 / -4.42	+3.48 / -3.44

Calculation for maximum uncertainty when 3m biconical antenna including a factor of k = 2 is used:

$$U = 2u_c(y) = 2x(+2.19) = +4.38 \text{ dB} \quad \text{And} \quad U = 2u_c(y) = 2x(-2.21) = -4.42 \text{ dB}$$

EXHIBIT 8. MEASUREMENT METHODS

8.1. GENERAL TEST CONDITIONS

The following test conditions shall be applied throughout the tests covered in this report.

8.1.1. Normal temperature and humidity

- Normal temperature: +15°C to +35°C
- Relative Humidity: +20% to 75%

The actual values during tests shall be recorded in the test report.

8.1.2. Normal power source

8.1.2.1. Mains Voltage

The nominal test voltage of the equipment to be connected to mains shall be the nominal mains voltage which is the declared voltage or any of the declared voltages for which the equipment was designed.

The frequency of test power source corresponding to the AC mains shall be between 59 Hz and 61 Hz.

8.1.2.2. Battery Power Source.

For operation from battery power sources, the nominal test voltage shall be as declared by the equipment manufacturer. This shall be recorded in the test report.

8.1.3. Operating Condition of Equipment under Test

- All tests were carried out while the equipment operated at the following frequencies:
 - The lowest operating frequency,
 - The middle operating frequency and
 - The highest operating frequency
- Modulation were applied using the Test Data sequence
- The transmitter was operated at the highest output power, or in the case the equipment able to operate at more than one power level, at the lowest and highest output powers

8.2. EQUIVALENT ISOTROPIC RADIATED POWER (EIRP)

- The following shall be applied to the combination(s) of the radio device and its intended antenna(e).
- If the RF level is user adjustable, all measurements shall be made with the highest power level available to the user for that combination.
- The following method of measurement shall apply to both conducted and radiated measurements.
- The radiated measurements are performed at the Ultratech Calibrated Open Field Test Site.
- The measurement shall be performed using normal operation of the equipment with modulation.

Test procedure shall be as follows:

Step 1: Duty Cycle measurements

- Using a spectrum analyzer with the frequency span set to 0 Hz and the sweep time set at a suitable value to capture the envelope peaks and the duty cycle of the transmitter output signal;
- The duty cycle of the transmitter, $x = \text{Tx on} / (\text{Tx on} + \text{Tx off})$ with $0 < x < 1$, is measure and recorded in the test report. For the purpose of testing, the equipment shall be operated with a duty cycle that is equal or more than 0.1.

Step 2: Calculation of Peak and Average EIRP

- The peak output power of the transmitter shall be determined using a wideband, calibrated RF Peak Power Meter with the power sensor with an integration period that exceeds the repetition period of the transmitter by a factor 5 or more. The observed value shall be recorded as “P” (in dBm);
- The Average EIRP shall be calculated from the above measured power output “A”, the observed duty cycle x, and the applicable antenna assembly gain “G” in dBi, according to the formula:

$$\text{Peak EIRP} = P + G$$

$$\text{Average EIRP} = \text{Peak EIRP} + 10\log(1/x)$$

Figure 1

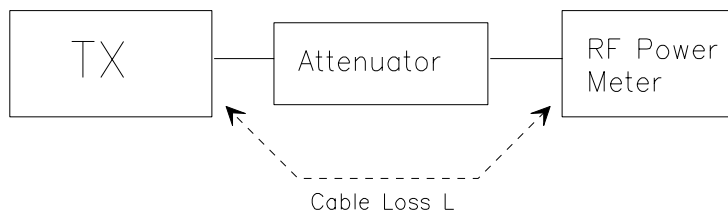

Step 3: Substitution Method. See Figure 2

- (a) The measurements was performed in the absence of modulation (un-modulated)
- (b) Test was performed at listed 3m open area test site (listed with FCC, IC, ITI, NVLAP, ACA & VCCI).
- (c) The transmitter under test was placed at the specified height on a non-conducting turntable (80 cm height)
- (d) The dipole test antenna was used and tuned to the transmitter carrier frequency.
- (e) The spectrum analyzer was tuned to transmitter carrier frequency. The test antenna was lowered or raised from 1 to 4 meters until the maximum signal level was detected.
- (f) The transmitter was rotated through 360° about a vertical axis until a higher maximum signal was received.
- (g) The test antenna was lowered or raised again from 1 to 4 meters until a maximum was obtained. This level was recorded.
- (h) The substitution dipole antenna and the signal generator replaced the transmitter and antenna under test in the same position, and the substitution dipole antenna was placed in vertical polarization. The test dipole antenna was lowered or raised as necessary to ensure that the maximum signal is stilled received.
- (i) The input signal to the substitution antenna was adjusted in level until an equal or a known related level to that detected from the transmitter was obtained in the test receiver. The maximum carrier radiated power is equal to the power supply by the generator.
- (j) The substitution antenna gain and cable loss were added to the signal generator level for the corrected ERP level.
- (k) Repeat steps (c) to (j) with the substitution antenna oriented in horizontal polarization.
- (l) Actual gain of the EUT's antenna is the difference of the measured ERP and measured RF power at the RF port. Correct the antenna gain if necessary.

Figure 2

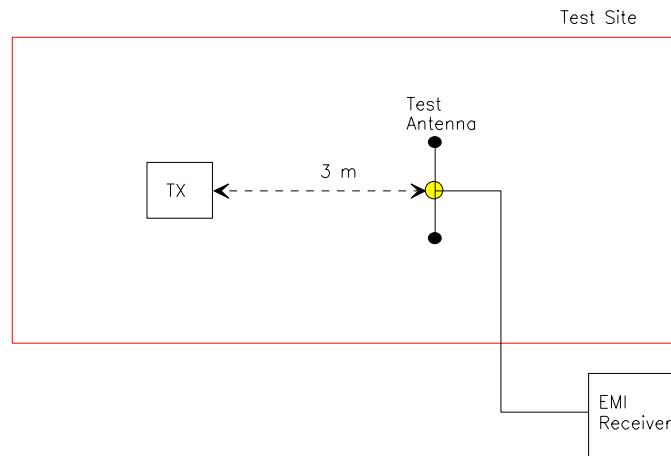
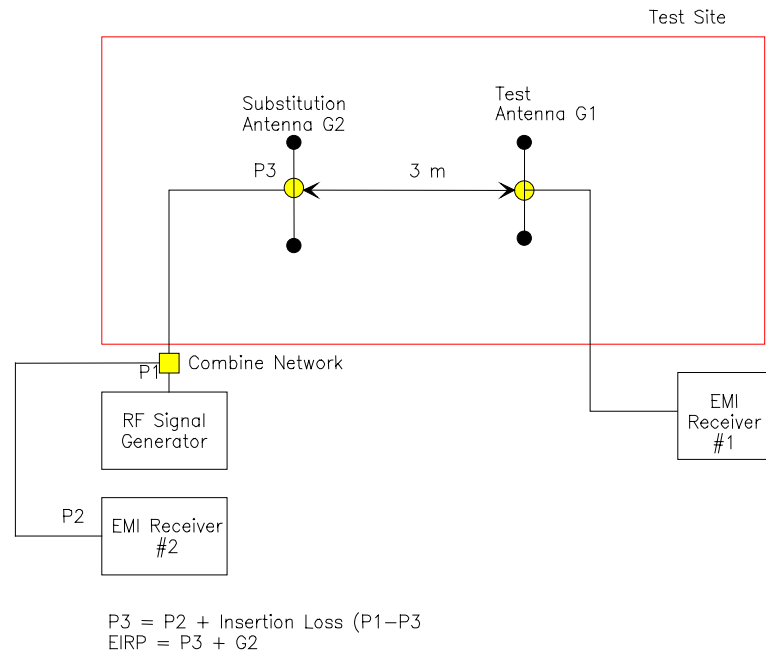

Figure 3



Use the following spectrum analyzer settings:

- Span = approximately 5 times the 20 dB BW, centered on a hopping channel
- RBW > 20 dB BW of the emission measured
- VBW = RBW
- Trace = max hold
- Allow the trace to stabilize
- Use the marker-to-marker function to set the marker to the peak of the emission.
- The indicated level is the peak output power (with the addition of the external attenuation and cable loss).
- The limit is specified in one of the subparagraphs of this Section.
- Submit this plot.
- A peak responding power meter may be used instead of a spectrum analyzer.

8.3. SPURIOUS EMISSIONS (CONDUCTED & RADIATED)

For both conducted and radiated measurements, the spurious emissions were scanned from the lowest frequency generated by the EUT or 10 MHz whichever is lower to 10th harmonic of the highest frequency generated by the EUT.

8.3.1. Band-Edge and Spurious Emissions (Conducted)

Band-Edge Compliance of RF Conducted Emissions:

Use the following spectrum analyzer settings:

- The radio was connected to the measuring equipment via a suitable attenuator.
- Span = wide enough to capture the peak level of the emission operating on the channel closest to the band-edge, as well as any modulation products which fall outside of the authorized band of operation.
- RBW = 1 % of the span
- VBW = RBW
- Sweep = auto
- Detector function = peak
- Trace = max hold
- Allow the trace to stabilize
- Set the marker on the emission at the band-edge, or on the highest modulation product outside of the band, if this level is greater than that at the band-edge
- Enable the marker-delta function, then use the marker-to-peak function to move the marker to the peak of the in-band emission.
- The marker-delta value now displayed must comply with the limit specified
- Now, using the same instrument settings, enable the hopping function of the EUT
- Allow the trace to stabilize
- Follow the same procedure listed above to determine if any spurious emissions cause by the hopping function also comply with the specify limits.
- Submit this plot

Spurious RF Conducted Emissions:

Use the following spectrum analyzer settings:

- The radio was connected to the measuring equipment via a suitable attenuator.
- Span = wide enough to capture the peak level of the in-band-emission and all spurious emissions (e.g. harmonics) from the lowest frequency generated in the EUT up through the 10th harmonic. Typically, several plots are required to cover this entire span.
- RBW = 100 kHz
- VBW = RBW
- Sweep = auto
- Detector function = peak
- Trace = max hold
- Allow the trace to stabilize
- Set the marker on the any spurious emission recorded. The level displayed must comply with the limit specified in this Section.
- Submit this plot

8.3.2. Spurious Emissions (Radiated)

- The radiated emission measurements were performed at the UltraTech's 3 Meter Open Field Test Site (OFTS) situated in the Town of Oakville, province of Ontario. The Attenuation Characteristics of OFTS have been filed to FCC, Industry Canada, ACA/Austel, NVLap and ITL.
- Radiated emissions measurements were made using the following test instruments:
 1. Calibrated EMCO BiconiLog antenna in the frequency range from 30 MHz to 2000 MHz.
 2. Calibrated Emco Horn antennas in the frequency range above 1000 MHz (1GHz - 40 GHz).
 3. The test is required for any spurious emission or modulation product that falls in a Restricted Band, as defined in Section 15.205. It must be performed with the highest gain of each type of antenna proposed for use with the EUT. Use the following spectrum analyzer settings:
 - RBW = 100 kHz for $f < 1\text{GHz}$ and RBW = 1 MHz for $f \geq 1\text{ GHz}$
 - VBW = RBW
 - Sweep = auto
 - Detector function = peak
 - Trace = max hold
 - Follows the guidelines in ANSI C63.4-1992 with respect to maximizing the emission by rotating the EUT, measuring the emission while the EUT is situated in three orthogonal planes (if appropriate), adjusting the measurement antenna height and polarization, etc.. A pre-amp and highpass filter are required for this test, in order to provide the measuring system with sufficient sensitivity.
 - Allow the trace to stabilize.
 - The peak reading of the emission, after being corrected by the antenna correction factor, cable loss, pre-amp gain, etc.... is the peak field strength which comply with the limit specified in Section 15.35(b)

Calculation of Field Strength:

The field strength is calculated by adding the calibrated antenna factor and cable factor, and subtracting the Amplifier gain (if any) from the measured reading. The basic equation with a sample calculation is as follows:

$$FS = RA + AF + CF - AG$$

Where FS = Field Strength
RA = Receiver/Analyzer Reading
AF = Antenna Factor
CF = Cable Attenuation Factor
AG = Amplifier Gain

Example: If a receiver reading of 60.0 dBuV is obtained, the antenna factor of 7.0 dB/m and cable factor of 1.0 dB are added, and the amplifier gain of 30 dB is subtracted. The actual field strength will be:

$$\begin{aligned} \text{Field Level} &= 60 + 7.0 + 1.0 - 30 = 38.0 \text{ dBuV/m.} \\ \text{Field Level} &= 10^{(38/20)} = 79.43 \text{ uV/m.} \end{aligned}$$

- Submit this test data
- Now set the VBW to 10Hz, while maintaining all of the other instrument settings. This peak level, once corrected, must comply with the limit specified in Section 15.209. If the dwell time per channel of the hopping signal is less than 100ms, then the reading obtained may be further adjusted by a “duty cycle correction factor”, derived from $10\log(\text{dwell time}/100\text{mS})$ in an effort to demonstrate compliance with the 15.209.
- Submit test data

Maximizing The Radiated Emissions:

- The frequencies of emissions was first detected. Then the amplitude of the emissions was measured at the specified measurement distance using required antenna height, polarization, and detector characteristics.
- During this process, cables and peripheral devices were manipulated within the range of likely configuration.
- For each mode of operation required to be tested, the frequency spectrum was monitored. Variations in antenna heights (from 1 meter to 4 meters above the ground plane), antenna polarization (horizontal plane and vertical plane), cable placement and peripheral placement were explored to produce the highest amplitude signal relative to the limit.

The maximum radiated emission for a given mode of operation was found by using the following step-by-step procedure:

- Step1: Monitor the frequency range of interest at a fixed antenna height and EUT azimuth.
- Step2: Manipulate the system cables to produce highest amplitude signal relative to the limit. Note the amplitude and frequency of the suspect signal.
- Step3: Rotate the EUT 360 degrees to maximize the suspected highest amplitude signal. If the signal or another at a different frequency is observed to exceed the previously noted highest amplitude signal by 1 dB or more, go back to the azimuth and repeat Step 2. Otherwise, orient the EUT azimuth to repeat the highest amplitude observation and proceed.
- Step4: Move the antenna over its full allowable range of travel (1 to 4 meters) to maximize the suspected highest amplitude signal. If the signal or another at a different frequency is observed to exceed the previously noted highest amplitude signal by 1 dB or more, return to Step 2 with the highest amplitude observation and proceed.
- Step5: Change the polarization of the antenna and repeat Step 2 through 4. Compare the resulting suspected highest amplitude signal with that found for the other polarization. Select and note the higher of the two signals. This signal is termed the highest observed signal with respect to the limit for this EUT operational mode.
- Step6: The effects of various modes of operation is examined. This is done by varying the equipment modes as steps 2 through 5 are being performed.
- Step7: After completing steps 1 through 6, record the final highest emission level, frequency, antenna polarization and detector mode of the measuring instrument.