

ENGINEERING TEST REPORT

FOR

EL705 OEM Series Radio
Model: EL7059(A, B or C)100AFT(2 or 3)N
FCC ID: E5MDS-EL705-9

IN ACCORDANCE WITH

FCC CFR 47, Parts 2 and 101
Non-Broadcast Radio Transceivers
Operating in the Frequency Bands 928 – 960 MHz
(12.5 kHz Channel Spacing)

TESTED FOR

Applicant: Microwave Data Systems Inc.
175 Science Parkway
Rochester, NY
USA, 14620-4261

ULTRATECH FILE NO. MIC42_TX

This Test Report is hereby issued under the Authority of Tri M. Luu, Professional Engineer, Vice President of Engineering UltraTech Group of Labs Inc.



Date: July 20, 2001

Report Prepared By: Mike Tom

Tested By: Hung Trinh, RFI Technician

Date: July 10, 2001

Date:

1. The Results contained in this Test Report apply only to the sample tested, which is randomly selected.
2. This report may not be reproduced in whole or in part without the prior written consent of UltraTech Engineering Labs Inc.
3. Under no circumstances may this report be used by the client to claim product endorsement by NVLAP or any agency of the US Government.

ULTRATECH

3000 BRISTOL CIRCLE, OAKVILLE, ONTARIO, CANADA, L6H 6G4
Telephone: 905-829-1570, Fax: 905-829-8050
Website: www.ultratech-labs.com
Email: vhk.ultratech@sympatico.ca, tri.luu@sympatico.ca

TABLE OF CONTENTS

EXHIBIT 1. SUBMITTAL CHECK LIST.....	1
EXHIBIT 2. INTRODUCTION	2
2.1. SCOPE	2
2.2. NORMATIVE REFERENCES.....	2
EXHIBIT 3. PERFORMANCE ASSESSMENT	3
3.1. APPLICANT INFORMATION	3
3.2. EQUIPMENT UNDER TEST (EUT) INFORMATION	3
3.3. EUT'S TECHNICAL SPECIFICATIONS	4
3.4. LIST OF EUT'S PORTS	4
3.5. MODIFICATIONS INCORPORATED IN THE EUT FOR COMPLIANCE PURPOSES	4
3.6. ANCILLARY EQUIPMENT	4
EXHIBIT 4. EUT OPERATING CONDITIONS AND CONFIGURATIONS DURING TESTS.....	5
4.1. CLIMATE TEST CONDITIONS	5
4.2. OPERATIONAL TEST CONDITIONS & ARRANGEMENT FOR TEST SIGNALS.....	5
EXHIBIT 5. SUMMARY OF TEST RESULTS	6
5.1. LOCATION OF TESTS.....	6
5.2. APPLICABILITY & SUMMARY OF TEST RESULTS.....	6
EXHIBIT 6. MEASUREMENTS, EXAMINATIONS & TEST DATA FOR EMC EMISSIONS.....	7
6.1. TEST PROCEDURES	7
6.2. MEASUREMENT UNCERTAINTIES.....	7
6.3. MEASUREMENT EQUIPMENT USED	7
6.4. ESSENTIAL/PRIMARY FUNCTIONS AS DECLARED BY THE MANUFACTURER	7
6.5. RF POWER OUTPUT @ FCC 2.1046 & 101.113.....	8
6.5.1. <i>Limits</i>	8
6.5.2. <i>Method of Measurements</i>	8
6.5.3. <i>Test Equipment List</i>	8
6.5.4. <i>Test Arrangement</i>	8
6.5.5. <i>Test Data</i>	9
6.6. MODULATION REQUIREMENTS @ FCC 2.1047	10
6.6.1. <i>Limits</i>	10
6.6.2. <i>Method of Measurements</i>	10
6.6.3. <i>Test Equipment List</i>	10
6.6.4. <i>Test Arrangement</i>	10
6.6.5. <i>Test Data</i>	11
6.7. EMISSION LIMITATION/EMISSION MASK @ FCC 2.1049 & 101.111	12
6.7.1. <i>Limits</i>	12
6.7.2. <i>Method of Measurements</i>	12
6.7.3. <i>Test Equipment List</i>	12
6.7.4. <i>Test Arrangement</i>	12
6.7.5. <i>Test Data</i>	12
6.8. TRANSMITTER ANTENNA SPURIOUS/HARMONIC CONDUCTED EMISSIONS @ FCC 2.1051.....	13
6.8.1. <i>Limits</i>	13
6.8.2. <i>Method of Measurements</i>	13
6.8.3. <i>Test Equipment List</i>	13
6.8.4. <i>Test Arrangement</i>	13

ULTRATECH GROUP OF LABS

3000 Bristol Circle, Oakville, Ontario, Canada L6H 6G4
Tel. #: 905-829-1570, Fax. #: 905-829-8050, Email: vhk.ultratech@sympatico.ca, Website: <http://www.ultratech-labs.com>

File #: MIC42_TX
July 10, 2001

- Assessed by ITI (UK) Competent Body, NVLAP (USA) Accreditation Body & ACA/AUSTEL (Australia)
- Accredited by Industry Canada (Canada) under ACC-LAB (Europe/Canada MRA)
- Recognized/Listed by FCC (USA)

All test results contained in this engineering test report are traceable to National Institute of Standards and Technology (NIST)

6.8.5.	Test Data	14
6.9.	TRANSMITTER SPURIOUS/HARMONIC RADIATED EMISSIONS @ FCC 2.1053.....	15
6.9.1.	Limits	15
6.9.2.	Method of Measurements.....	15
6.9.3.	Test Equipment List.....	15
6.9.4.	Test Arrangement.....	16
6.9.5.	Test Data	16
6.10.	FREQUENCY STABILITY @ FCC 2.1055 & 101.107	20
6.10.1.	Limits.....	20
6.10.2.	Method of Measurements.....	20
6.10.3.	Test Equipment List.....	20
6.10.4.	Test Arrangement.....	20
6.10.5.	Test Data	21
EXHIBIT 7.	MEASUREMENT UNCERTAINTY	22
7.1.	RADIATED EMISSION MEASUREMENT UNCERTAINTY	22
EXHIBIT 8.	MEASUREMENT METHODS.....	23
8.1.	EFFECTIVE RADIATED POWER (ERP) MEASUREMENTS.....	23
8.2.	FREQUENCY STABILITY	27
8.3.	EMISSION MASK	28
8.4.	SPURIOUS EMISSIONS (CONDUCTED)	28
8.5.	SPURIOUS EMISSIONS (RADIATED)	29
8.5.1.	Maximizing RF Emission Level	29
8.5.2.	Measuring the EIRP of Spurious/Harmonic Emissions using Substitution Method	29
ANNEX A.	PLOTS OF MEASUREMENT DATA.....	30
ANNEX B.	PHOTOGRAPHS OF TEST SETUP	31
ANNEX C.	EXTERNAL PHOTOGRAPHS OF EUT	32
ANNEX D.	INTERNAL PHOTOGRAPHS OF EUT	33
ANNEX E.	COVER LETTERS.....	34
ANNEX F.	USERS MANUAL	35
ANNEX G.	APPLICATION FORMS.....	36
ANNEX H.	ID LABEL AND LOCATION INFORMATION	37
ANNEX I.	BLOCK DIAGRAM	38
ANNEX J.	SCHEMATIC DIAGRAMS	39
ANNEX K.	PARTS LIST / TUNE UP INFORMATION.....	40
ANNEX L.	OPERATIONAL DESCRIPTION	41

ULTRATECH GROUP OF LABS

3000 Bristol Circle, Oakville, Ontario, Canada L6H 6G4
Tel. #: 905-829-1570, Fax. #: 905-829-8050, Email: vhk.ultratech@sympatico.ca, Website: http://www.ultratech-labs.com

File #: MIC42_TX
July 10, 2001

- Assessed by ITI (UK) Competent Body, NVLAP (USA) Accreditation Body & ACA/AUSTEL (Australia)
- Accredited by Industry Canada (Canada) under ACC-LAB (Europe/Canada MRA)
- Recognized/Listed by FCC (USA)

All test results contained in this engineering test report are traceable to National Institute of Standards and Technology (NIST)

EXHIBIT 1. SUBMITTAL CHECK LIST

Annex	Exhibit Type	Description of Contents	Quality Check (OK)
--	Test Report	<ul style="list-style-type: none"> Exhibit 1: Submittal check lists Exhibit 2: Introduction Exhibit 3: Performance Assessment Exhibit 4: EUT Operation and Configuration during Tests Exhibit 5: Summary of test Results Exhibit 6: Measurement Data Exhibit 7: Measurement Uncertainty Exhibit 8: Measurement Methods 	OK
A	Test Report - Plots of Measurement Data	Plots # 1 to 17	OK
B	Test Setup Photos	Photos # 1 to 4	OK
C	External Photos of EUT	Photos # 1 to 3	OK
D	Internal Photos of EUT	Photos #1 to 3	OK
E	Cover Letters	<ul style="list-style-type: none"> Letter from UltraTech for Certification Request Letter from the Applicant to appoint UltraTech to act as an agent Letter from the Applicant to request for Confidentiality Filing 	OK OK OK
F	Users Manual	Operating Instructions	OK
G	Application Forms	<ul style="list-style-type: none"> Form 731 Form 159 Confirmation of Exhibits sent to FCC Status of Exhibits sent to FCC 	OK
H	ID Label/Location Info	<ul style="list-style-type: none"> ID Label Location of ID Label 	OK OK
I	Block Diagrams	Block Diagram of Transmitter	OK
J	Schematic Diagrams	Schematic Diagrams for EL705	OK
K	Parts List/Tune Up Info	Bill of Materials	OK
L	Operational Description	Theory of Operation	OK

ULTRATECH GROUP OF LABS

3000 Bristol Circle, Oakville, Ontario, Canada L6H 6G4
 Tel. #: 905-829-1570, Fax. #: 905-829-8050, Email: vhk.ultratech@sympatico.ca, Website: http://www.ultratech-labs.com

File #: MIC42_TX
 July 10, 2001

- Assessed by ITI (UK) Competent Body, NVLAP (USA) Accreditation Body & ACA/AUSTEL (Australia)
- Accredited by Industry Canada (Canada) under ACC-LAB (Europe/Canada MRA)
- Recognized/Listed by FCC (USA)

All test results contained in this engineering test report are traceable to National Institute of Standards and Technology (NIST)

EXHIBIT 2. INTRODUCTION

2.1. SCOPE

Reference:	FCC Parts 2 and 101 (1998)
Title	Telecommunication - Code of Federal Regulations, CFR 47, Parts 2 and 101
Purpose of Test:	To gain FCC Certification Authorization for Non-Broadcast Radio Transceivers
Test Procedures	Both conducted and radiated emissions measurements were conducted in accordance with American National Standards Institute ANSI C63.4 - American National Standard for Methods of Measurement of Radio-Noise Emissions from Low-Voltage Electrical and Electronic Equipment in the Range of 9 kHz to 40 GHz.

2.2. NORMATIVE REFERENCES

Publication	Year	Title
FCC CFR 47, Parts 2 and 101	1998	Code of Federal Regulations – Telecommunication
ANSI C63.4	1992	American National Standard for Methods of Measurement of Radio-Noise Emissions from Low-Voltage Electrical and Electronic Equipment in the Range of 9 kHz to 40 GHz
CISPR 22 & EN 55022	1997 1998	Limits and Methods of Measurements of Radio Disturbance Characteristics of Information Technology Equipment
CISPR 16-1		Specification for Radio Disturbance and Immunity measuring apparatus and methods
TIA/EIA-603	1993	Land Mobile FM or PM Communications Equipment Measurement and Performance Standards

ULTRATECH GROUP OF LABS

3000 Bristol Circle, Oakville, Ontario, Canada L6H 6G4
Tel. #: 905-829-1570, Fax. #: 905-829-8050, Email: vhk.ultratech@sympatico.ca, Website: <http://www.ultratech-labs.com>

File #: MIC42_TX
July 10, 2001

- Assessed by ITI (UK) Competent Body, NVLAP (USA) Accreditation Body & ACA/AUSTEL (Australia)
- Accredited by Industry Canada (Canada) under ACC-LAB (Europe/Canada MRA)
- Recognized/Listed by FCC (USA)

All test results contained in this engineering test report are traceable to National Institute of Standards and Technology (NIST)

EXHIBIT 3. PERFORMANCE ASSESSMENT

3.1. APPLICANT INFORMATION

APPLICANT	
Name:	Microwave Data Systems Inc.
Address:	175 Science Parkway Rochester, NY USA, 14620-4261
Contact Person:	Mr. Dennis McCarthy Phone #: 716-242-8440 Fax #: 716-241-5590 Email Address: dmcarthy@microwavedata.com

MANUFACTURER	
Name:	Microwave Data Systems Inc.
Address:	175 Science Parkway Rochester, NY USA, 14620-4261
Contact Person:	Mr. Dennis McCarthy Phone #: 716-242-8440 Fax #: 716-241-5590 Email Address: dmcarthy@microwavedata.com

3.2. EQUIPMENT UNDER TEST (EUT) INFORMATION

The following information (with the exception of the Date of Receipt) has been supplied by the applicant.

Brand Name	Microwave Data Systems Inc.
Product Name	EL705 OEM Series Radio
Model Name or Number	EL7059(A, B or C)100AFT(2 or 3)N
Serial Number	Not Available
Type of Equipment	Radio Communication Equipment
External Power Supply	Yes 10-16 Vdc
Transmitting/Receiving Antenna Type	Non-integral
Primary User Functions of EUT:	To correctly communicate information via RF link through air.

ULTRATECH GROUP OF LABS

3000 Bristol Circle, Oakville, Ontario, Canada L6H 6G4
Tel. #: 905-829-1570, Fax. #: 905-829-8050, Email: vhk.ultratech@sympatico.ca, Website: <http://www.ultratech-labs.com>

File #: MIC42_TX
July 10, 2001

- Assessed by ITI (UK) Competent Body, NVLAP (USA) Accreditation Body & ACA/AUSTEL (Australia)
- Accredited by Industry Canada (Canada) under ACC-LAB (Europe/Canada MRA)
- Recognized/Listed by FCC (USA)

All test results contained in this engineering test report are traceable to National Institute of Standards and Technology (NIST)

3.3. EUT'S TECHNICAL SPECIFICATIONS

TRANSMITTER	
Equipment Type:	Base station (fixed use)
Intended Operating Environment:	Commercial, light industry & heavy industry
Power Supply Requirement:	10 – 16 Vdc
RF Output Power Rating:	250 mW, 1 Watt, 5 Watts (Programmable)
Duty Cycle:	50%
Operating Frequency Range:	928-960 MHz
RF Output Impedance:	50 Ohms
Channel Spacing:	12.5 kHz
Occupied Bandwidth (99%): ⁽¹⁾	8.64 kHz
Emission Designation: ⁽²⁾	9K4F1D, 9K4F2D
Oscillator Frequencies:	1 st IF (rx-45MHz), 2 IF(44.55MHz), TCXO16MHz,
Antenna Connector Type:	BNC

(1) Refer to Plots #1 to 3 in Annex A for measurement details of the Occupied Bandwidth

(2) Refer to Section 6.6.5.2 of this test report for details of calculation.

3.4. LIST OF EUT'S PORTS

Port Number	EUT's Port Description	Number of Identical Ports	Connector Type	Cable Type (Shielded/Non-shielded)
1	Data port	1	DB25	shielded
2	RF antenna connector	1	BNC	Shielded coax
3	2 pin Molex DC power	1	2 pin molded	Non- shielded

NOTES: Ports of the EUT which in normal operation were connected to ancillary equipment through interconnecting cables via a representative interconnecting cable to simulate the input/output characteristics. RF input/output was correctly terminated to the 50 Ohm RF Load.

3.5. MODIFICATIONS INCORPORATED IN THE EUT FOR COMPLIANCE PURPOSES

None.

3.6. ANCILLARY EQUIPMENT

The EUT was tested while connected to the following representative configuration of ancillary equipment necessary to exercise the ports during tests:

Ancillary Equipment # 1	
Description:	MDS hand held terminal
Brand name:	MDS HHT (hand held terminal)
Cable Length & Type:	2 foot data cable
Connected to EUT's Port:	DB 25 connector to enable the transmitter

ULTRATECH GROUP OF LABS

3000 Bristol Circle, Oakville, Ontario, Canada L6H 6G4
 Tel. #: 905-829-1570, Fax. #: 905-829-8050, Email: vhk.ultratech@sympatico.ca, Website: http://www.ultratech-labs.com

File #: MIC42_TX
 July 10, 2001

- Assessed by ITI (UK) Competent Body, NVLAP (USA) Accreditation Body & ACA/AUSTEL (Australia)
- Accredited by Industry Canada (Canada) under ACC-LAB (Europe/Canada MRA)
- Recognized/Listed by FCC (USA)

All test results contained in this engineering test report are traceable to National Institute of Standards and Technology (NIST)

EXHIBIT 4. EUT OPERATING CONDITIONS AND CONFIGURATIONS DURING TESTS

4.1. CLIMATE TEST CONDITIONS

The climate conditions of the test environment are as follows:

Temperature:	21°C
Humidity:	51%
Pressure:	102 kPa
Power input source:	13.8 Vdc Nominal

4.2. OPERATIONAL TEST CONDITIONS & ARRANGEMENT FOR TEST SIGNALS

Operating Modes:	The transmitter was operated in a continuous transmission mode with the carrier modulated as specified in the Test Data.
Special Test Software:	None
Special Hardware Used:	None
Transmitter Test Antenna:	The EUT is tested with the transmitter antenna port terminated to a 50 Ohm RF Load.

Transmitter Test Signals	
Frequencies: <ul style="list-style-type: none">928 – 960 MHz	Near lowest, near middle & near highest frequencies each frequency bands that the transmitter covers: <ul style="list-style-type: none">928 MHz, 944 MHz, 960 MHz
Transmitter Wanted Output Test Signals: <ul style="list-style-type: none">RF Power Output (measured maximum output power):Normal Test ModulationModulating signal source:	<ul style="list-style-type: none">5 Watts4 Level CPFSKInternal

ULTRATECH GROUP OF LABS

3000 Bristol Circle, Oakville, Ontario, Canada L6H 6G4
Tel. #: 905-829-1570, Fax. #: 905-829-8050, Email: vhk.ultratech@sympatico.ca, Website: <http://www.ultratech-labs.com>

File #: MIC42_TX
July 10, 2001

- Assessed by ITI (UK) Competent Body, NVLAP (USA) Accreditation Body & ACA/AUSTEL (Australia)
- Accredited by Industry Canada (Canada) under ACC-LAB (Europe/Canada MRA)
- Recognized/Listed by FCC (USA)

All test results contained in this engineering test report are traceable to National Institute of Standards and Technology (NIST)

EXHIBIT 5. SUMMARY OF TEST RESULTS

5.1. LOCATION OF TESTS

All of the measurements described in this report were performed at UltraTech Group of Labs located in the city of Oakville, Province of Ontario, Canada.

- Radiated Emissions were performed at the Ultratech's 3 Meter Open Field Test Site (OFTS) situated in the Town of Oakville, province of Ontario.

The above sites have been calibrated in accordance with ANSI C63.4, and found to be in compliance with the requirements of Sec. 2.948 of the FCC Rules. The descriptions and site measurement data of the Oakville Open Field Test Site has been filed with FCC office (FCC File No.: 31040/SIT 1300B3) and Industry Canada office (Industry Canada File No.: IC2049). Last Date of Site Calibration: Sep. 20, 1999.

5.2. APPLICABILITY & SUMMARY OF TEST RESULTS

FCC Paragraph.	Test Requirements	Applicability (Yes/No)
2.1046 & 101.113	RF Power Output	Yes
2.1047	Modulation Requirements	Yes
101.111	Emission Masks	Yes
2.1049 & 101.109	Occupied Bandwidths	Yes
2.1051	Emission Limits – Spurious Emissions at Antenna Terminal	Yes
2.1053	Emission Limits – Field Strength of Spurious Emissions	Yes
2.1055 & 101.107	Frequency Stability	Yes

EL705 OEM Series Radio, Model No.: EL7059(A,B or C)100AFT(2 or 3)N, by Microwave Data Systems Inc. has also been tested and found to comply with **FCC Part 15, Subpart B - Radio Receivers and Class A Digital Devices**. The engineering test report has been documented and is kept on file. This report can be made available to the FCC upon request.

ULTRATECH GROUP OF LABS

3000 Bristol Circle, Oakville, Ontario, Canada L6H 6G4
Tel. #: 905-829-1570, Fax. #: 905-829-8050, Email: vhk.ultratech@sympatico.ca, Website: http://www.ultratech-labs.com

File #: MIC42_TX
July 10, 2001

- Assessed by ITI (UK) Competent Body, NVLAP (USA) Accreditation Body & ACA/AUSTEL (Australia)
- Accredited by Industry Canada (Canada) under ACC-LAB (Europe/Canada MRA)
- Recognized/Listed by FCC (USA)

All test results contained in this engineering test report are traceable to National Institute of Standards and Technology (NIST)

EXHIBIT 6. MEASUREMENTS, EXAMINATIONS & TEST DATA FOR EMC EMISSIONS

6.1. TEST PROCEDURES

This section contains test results only. Details of test methods and procedures can be found in Exhibit 8 of this report

6.2. MEASUREMENT UNCERTAINTIES

The measurement uncertainties stated were calculated in accordance with requirements of UKAS Document NIS 81 with a confidence level of 95%. Please refer to Exhibit 7 for Measurement Uncertainties.

6.3. MEASUREMENT EQUIPMENT USED

The measurement equipment used complied with the requirements of the Standards referenced in the Methods & Procedures ANSI C63.4:1992 and CISPR 16-1.

6.4. ESSENTIAL/PRIMARY FUNCTIONS AS DECLARED BY THE MANUFACTURER

The essential function of the EUT is to correctly communicate data to and from radios over RF link.

ULTRATECH GROUP OF LABS

3000 Bristol Circle, Oakville, Ontario, Canada L6H 6G4
Tel. #: 905-829-1570, Fax. #: 905-829-8050, Email: vhk.ultratech@sympatico.ca, Website: <http://www.ultratech-labs.com>

File #: MIC42_TX
July 10, 2001

- Assessed by ITI (UK) Competent Body, NVLAP (USA) Accreditation Body & ACA/AUSTEL (Australia)
- Accredited by Industry Canada (Canada) under ACC-LAB (Europe/Canada MRA)
- Recognized/Listed by FCC (USA)

All test results contained in this engineering test report are traceable to National Institute of Standards and Technology (NIST)

6.5. RF POWER OUTPUT @ FCC 2.1046 & 101.113

6.5.1. Limits

Frequency Range (MHz)	Maximum Allowed EIRP (dBW) (Fixed)
928 – 929	+17
932 – 932.5	+17
941 – 941.5	+30
941.5 – 944	+40
952 – 960	+40

6.5.2. Method of Measurements

Please refer to Exhibit 8, Sec. 8.1 for test procedures and test setup

- The transmitter terminal was coupled to the Power meter through a 20 dB attenuator
- Power of the transmitter channel near the lowest, middle and highest of each frequency block/band were measured using the power meter, and the reading was corrected by added the calibrated attenuator's attenuation value and cable loss.
- The RF output was turned on with standard modulation applied.

6.5.3. Test Equipment List

Test Instruments	Manufacturer	Model No.	Serial No.	Frequency Range
Attenuator(s)	Weinschel Corp	24-20-34	BJ2357	DC – 8.5 GHz
Average Power Meter	Hewlett Packard	HP 436A	1725A02249	10kHz to 50GHz @ 50 Ohm input
Power Probe sensor	Hewlett Packard	HP 8481A	2702A68983	100 MHz to 18 GHz @ 50 Ohms input
Attenuator(s)	Bird	DC – 22 GHz

6.5.4. Test Arrangement

- Power at RF Power Output Terminals

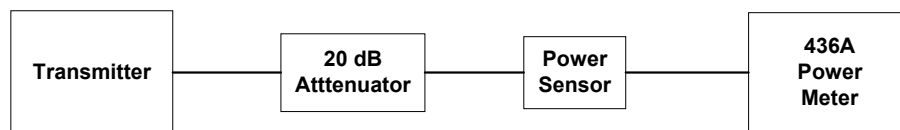

ULTRATECH GROUP OF LABS

3000 Bristol Circle, Oakville, Ontario, Canada L6H 6G4
 Tel. #: 905-829-1570, Fax. #: 905-829-8050, Email: vhk.ultratech@sympatico.ca, Website: http://www.ultratech-labs.com

File #: MIC42_TX
 July 10, 2001

- Assessed by ITI (UK) Competent Body, NVLAP (USA) Accreditation Body & ACA/AUSTEL (Australia)
- Accredited by Industry Canada (Canada) under ACC-LAB (Europe/Canada MRA)
- Recognized/Listed by FCC (USA)

All test results contained in this engineering test report are traceable to National Institute of Standards and Technology (NIST)

6.5.5. Test Data

Transmitter Channel Output	Fundamental Frequency (MHz)	Measured Power (P) (dBm)
Lowest	928	37
Middle	944	37
Highest	960	37

Note: Applicable antenna gain shall be chosen such that the maximum allowable EIRP is less than the limits specified in FCC rules, Part 101.113.

$$EIRP = \text{Conducted Power (P) (dBm)} + \text{Antenna Gain (G) (dBi)}.$$

ULTRATECH GROUP OF LABS

3000 Bristol Circle, Oakville, Ontario, Canada L6H 6G4
Tel. #: 905-829-1570, Fax. #: 905-829-8050, Email: vhk.ultratech@sympatico.ca, Website: <http://www.ultratech-labs.com>

File #: MIC42_TX
July 10, 2001

- Assessed by ITI (UK) Competent Body, NVLAP (USA) Accreditation Body & ACA/AUSTEL (Australia)
- Accredited by Industry Canada (Canada) under ACC-LAB (Europe/Canada MRA)
- Recognized/Listed by FCC (USA)

All test results contained in this engineering test report are traceable to National Institute of Standards and Technology (NIST)

6.6. MODULATION REQUIREMENTS @ FCC 2.1047

6.6.1. Limits

The EUT shall be installed with a modulation limiter which limits the deviation of the FM carrier less than manufacturer's setting provided that the RF output spectrum must meet the required MASK.

Recommendation:

- 1.25 kHz for 6.25 kHz Channel Spacing System,
- 2.5 kHz for 12.5 kHz Channel Spacing,
- 5 kHz for 25 kHz Channel Spacing System

6.6.2. Method of Measurements

For Data Transmitter with Maximum Frequency Deviation set by Factory:- The EUT was set at maximum frequency deviation, and its peak frequency deviation was then measured using EUT's internal random data source.

6.6.3. Test Equipment List

Test Instruments	Manufacturer	Model No.	Serial No.	Frequency Range
Communication Analyzer	Rohde & Schwarz	SMF02	879988/057	400 kHz - 1000 MHz including AF & RF Signal Generators, SINAD, DISTORTION, DEVIATION meters and etc

6.6.4. Test Arrangement

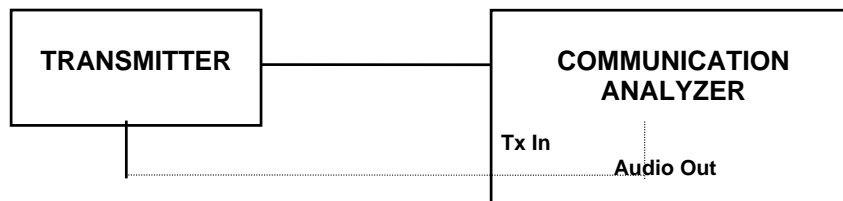

ULTRATECH GROUP OF LABS

3000 Bristol Circle, Oakville, Ontario, Canada L6H 6G4
Tel. #: 905-829-1570, Fax. #: 905-829-8050, Email: vhk.ultratech@sympatico.ca, Website: <http://www.ultratech-labs.com>

File #: MIC42_TX
July 10, 2001

- Assessed by ITI (UK) Competent Body, NVLAP (USA) Accreditation Body & ACA/AUSTEL (Australia)
- Accredited by Industry Canada (Canada) under ACC-LAB (Europe/Canada MRA)
- Recognized/Listed by FCC (USA)

All test results contained in this engineering test report are traceable to National Institute of Standards and Technology (NIST)

6.6.5. Test Data

6.6.5.1. Data Modulation Limiting: FM modulation and Modulation Limiter set at a Maximum Frequency Deviation (Factory Setting).

DATA BAUD RATE	PEAK DEVIATION (KHz)
4800	2.3
9600	2.3

6.6.5.2. Emission Designation Calculations

For FM Digital Modulation:

Channel Spacing = 12.5 kHz,

D = 2.3 KHz max.,

K = 1

M = 9.6/4 kb/s

- i. $B_n = 2M + 2DK$
 $= 2(9.6/4) + 2(2.3)(1) = \underline{9.4 \text{ KHz}}$
- ii. emission designation: 9K4F1D and 9K4F2D

ULTRATECH GROUP OF LABS

3000 Bristol Circle, Oakville, Ontario, Canada L6H 6G4
Tel. #: 905-829-1570, Fax. #: 905-829-8050, Email: vhk.ultratech@sympatico.ca, Website: <http://www.ultratech-labs.com>

File #: MIC42_TX
July 10, 2001

- Assessed by ITI (UK) Competent Body, NVLAP (USA) Accreditation Body & ACA/AUSTEL (Australia)
- Accredited by Industry Canada (Canada) under ACC-LAB (Europe/Canada MRA)
- Recognized/Listed by FCC (USA)

All test results contained in this engineering test report are traceable to National Institute of Standards and Technology (NIST)

6.7. EMISSION LIMITATION/EMISSION MASK @ FCC 2.1049 & 101.111

6.7.1. Limits

Please refer to the appropriate paragraph of Part 101.111 for details of the applicable limits.

6.7.2. Method of Measurements

Please refer to FCC 2.1049(h) and Exhibit 8, Sec. 8.3 for detailed test procedures.

6.7.3. Test Equipment List

Test Instruments	Manufacturer	Model No.	Serial No.	Frequency Range
Spectrum Analyzer/ EMI Receiver	Advantest	R3271	15050203	100 Hz – 26.5 GHz
Attenuator(s)	Bird	DC – 22 GHz

6.7.4. Test Arrangement

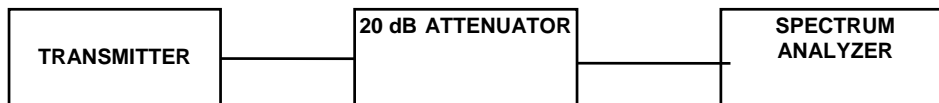

6.7.5. Test Data

Conforms. Please refer to the Plots # 4 to 11 in Annex A for detailed measurement.

ULTRATECH GROUP OF LABS

3000 Bristol Circle, Oakville, Ontario, Canada L6H 6G4
Tel. #: 905-829-1570, Fax. #: 905-829-8050, Email: vhk.ultratech@sympatico.ca, Website: <http://www.ultratech-labs.com>

File #: MIC42_TX
July 10, 2001

- Assessed by ITI (UK) Competent Body, NVLAP (USA) Accreditation Body & ACA/AUSTEL (Australia)
- Accredited by Industry Canada (Canada) under ACC-LAB (Europe/Canada MRA)
- Recognized/Listed by FCC (USA)

All test results contained in this engineering test report are traceable to National Institute of Standards and Technology (NIST)

6.8. TRANSMITTER ANTENNA SPURIOUS/HARMONIC CONDUCTED EMISSIONS @ FCC 2.1051

6.8.1. Limits

Refer to the appropriate limits of FCC rules Part 101.111.

6.8.2. Method of Measurements

Refer to Exhibit 8 § 8.4 of this report for measurement details

6.8.3. Test Equipment List

Test Instruments	Manufacturer	Model No.	Serial No.	Frequency Range
Spectrum Analyzer/ EMI Receiver	Advantest	R3271	15050203	100 Hz – 26.5 GHz
Attenuator(s)	Bird	DC – 22 GHz
Highpass Filter, Microphase	Microphase	CR220HID	IIT111000AC	Cut-off Frequency at 600 MHz, 1.3 GHz or 4 GHz

6.8.4. Test Arrangement

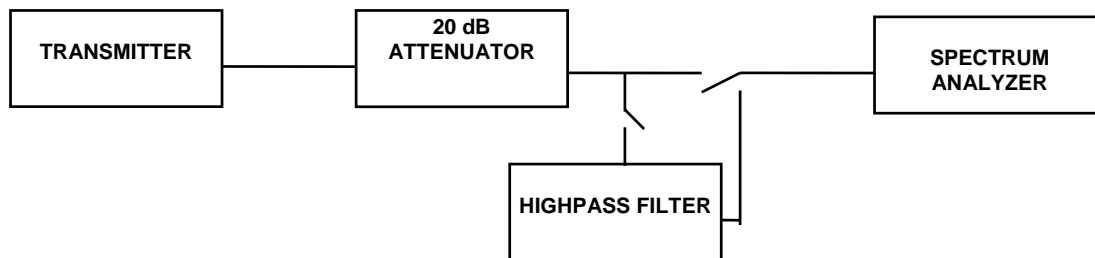

ULTRATECH GROUP OF LABS

3000 Bristol Circle, Oakville, Ontario, Canada L6H 6G4
Tel. #: 905-829-1570, Fax. #: 905-829-8050, Email: vkh.ultratech@sympatico.ca, Website: <http://www.ultratech-labs.com>

File #: MIC42_TX
July 10, 2001

- Assessed by ITI (UK) Competent Body, NVLAP (USA) Accreditation Body & ACA/AUSTEL (Australia)
- Accredited by Industry Canada (Canada) under ACC-LAB (Europe/Canada MRA)
- Recognized/Listed by FCC (USA)

All test results contained in this engineering test report are traceable to National Institute of Standards and Technology (NIST)

6.8.5. Test Data

UNDER THE FOLLOWING TEST MODULATION:

FM MODULATION WITH INTERNAL 4 LEVEL CPFSK:

THE EUT WAS OPERATED NEAR THE LOWEST FREQUENCY, NEAR THE MIDDLE FREQUENCY AND NEAR THE HIGHEST FREQUENCY OF THE OPERATING BAND. AT EACH FREQUENCY, THE EUT WAS SCANNED FROM 10 MHz TO 10 GHz, AND ALL EMISSIONS FOUND WERE MORE THAN 20 dB BELOW THE LIMITS.

PLEASE REFER TO THE PLOTS #12 to 17 IN ANNEX A FOR MEASUREMENT DETAILS.

ULTRATECH GROUP OF LABS

3000 Bristol Circle, Oakville, Ontario, Canada L6H 6G4
Tel. #: 905-829-1570, Fax. #: 905-829-8050, Email: vhk.ultratech@sympatico.ca, Website: <http://www.ultratech-labs.com>

File #: MIC42_TX
July 10, 2001

- Assessed by ITI (UK) Competent Body, NVLAP (USA) Accreditation Body & ACA/AUSTEL (Australia)
- Accredited by Industry Canada (Canada) under ACC-LAB (Europe/Canada MRA)
- Recognized/Listed by FCC (USA)

All test results contained in this engineering test report are traceable to National Institute of Standards and Technology (NIST)

6.9. TRANSMITTER SPURIOUS/HARMONIC RADIATED EMISSIONS @ FCC 2.1053

6.9.1. Limits

Refer to the appropriate limits of FCC rules Part 101.111.

6.9.2. Method of Measurements

Refer to Exhibit 8, § 8.1 and 8.5 of this report for measurement details. Method of measurements can be referenced to TIA/EIA-603 standard, Section 2.2.12

6.9.3. Test Equipment List

Test Instruments	Manufacturer	Model No.	Serial No.	Frequency Range
Spectrum Analyzer/ EMI Receiver	Advantest	R3271	15050203	100 Hz to 32 GHz with external mixer for frequency above 32 GHz
Spectrum Analyzer/ EMI Receiver	Hewlett Packard	HP 8593EM	3412A00103	9 kHz – 26.5 GHz
Microwave Amplifier	Hewlett Packard	HP 83017A	3116A00661	1 GHz to 26.5 GHz, 30 dB gain nominal
RF Pre-Amplifier	Com-Power	PA -102	1425	30 MHz – 1 GHz, 30 dB gain Nominal
RF Signal Generator	Hewlett Packard	HP 83752B	3610A00457	0.01 – 20 GHz
Biconilog Antenna	EMCO	3142	10005	30 MHz to 2 GHz
Dipole Antenna	EMCO	3121C	8907-434	30-1000 MHz
Dipole Antenna	EMCO	3121C	8907-440	30-1000 MHz
Horn Antenna	EMCO	3155	9701-5061	1 GHz – 18 GHz
Horn Antenna	EMCO	3155	9911-5955	1 GHz – 18 GHz

ULTRATECH GROUP OF LABS

3000 Bristol Circle, Oakville, Ontario, Canada L6H 6G4
Tel. #: 905-829-1570, Fax. #: 905-829-8050, Email: vhk.ultratech@sympatico.ca, Website: <http://www.ultratech-labs.com>

File #: MIC42_TX
July 10, 2001

- Assessed by ITI (UK) Competent Body, NVLAP (USA) Accreditation Body & ACA/AUSTEL (Australia)
- Accredited by Industry Canada (Canada) under ACC-LAB (Europe/Canada MRA)
- Recognized/Listed by FCC (USA)

All test results contained in this engineering test report are traceable to National Institute of Standards and Technology (NIST)

6.9.4. Test Arrangement

The following block diagram show details of the test setup for radiated emissions measurements
Refer to Annex B for photographs of test setup.

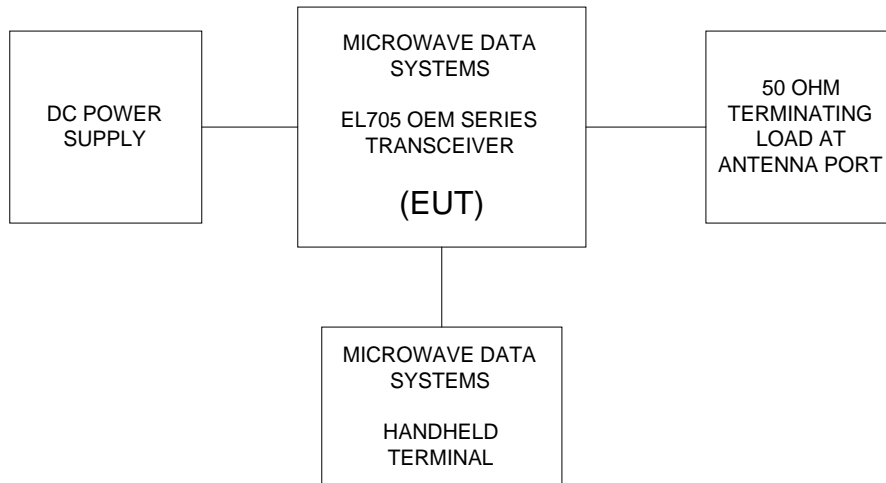

6.9.5. Test Data

Remarks For the Following Test Data:

- THE RADIATED EMISSIONS WERE PERFORMED AT 3 METERS DISTANCE.
- MAXIMUM RF POWER OUTPUT IS 5 WATTS OR 37 dBm.
- FM MODULATION WITH INTERNAL 4 LEVEL CPFSK.
- SCANS WERE PERFORMED NEAR THE LOWEST, MIDDLE AND HIGHEST FREQUENCIES OF THE OPERATING BAND.
- AT EACH FREQUENCY, EMISSIONS WERE SCANNED FROM 10 MHz TO 10 GHz, AND ALL EMISSIONS LESS THAN 20 dBc BELOW THE LIMIT IS RECORDED.

ULTRATECH GROUP OF LABS

3000 Bristol Circle, Oakville, Ontario, Canada L6H 6G4
Tel. #: 905-829-1570, Fax. #: 905-829-8050, Email: vhk.ultratech@sympatico.ca, Website: <http://www.ultratech-labs.com>

File #: MIC42_TX
July 10, 2001

- Assessed by ITI (UK) Competent Body, NVLAP (USA) Accreditation Body & ACA/AUSTEL (Australia)
- Accredited by Industry Canada (Canada) under ACC-LAB (Europe/Canada MRA)
- Recognized/Listed by FCC (USA)

All test results contained in this engineering test report are traceable to National Institute of Standards and Technology (NIST)

6.9.5.1. Near Lowest Frequency (928 MHz)

RF POWER OUTPUT: 37 dBm

FREQUENCY (MHz)	Substitution Method		DETECTOR USED (PEAK/QP)	ANTENNA PLANE (H/V)	ERP Limit (dBc)	MARGIN (dB)	PASS/ FAIL
	ERP (dBm)	ERP (dBc)					
1856.00	-29.8	-66.8	PEAK	V	-57.0	-9.8	PASS
1856.00	-38.2	-75.1	PEAK	H	-57.0	-18.2	PASS
2784.00	-30.3	-67.3	PEAK	V	-57.0	-10.3	PASS
2784.00	-37.8	-74.8	PEAK	H	-57.0	-17.8	PASS
3712.00	-28.1	-65.0	PEAK	V	-57.0	-8.1	PASS
3712.00	-30.7	-67.6	PEAK	H	-57.0	-10.7	PASS
4640.00	-27.0	-64.0	PEAK	V	-57.0	-7.0	PASS
4640.00	-31.2	-68.2	PEAK	H	-57.0	-11.2	PASS
5568.00	-34.4	-71.4	PEAK	V	-57.0	-14.4	PASS
5568.00	-37.6	-74.6	PEAK	H	-57.0	-17.6	PASS
6496.00	-37.7	-74.6	PEAK	V	-57.0	-17.7	PASS
7424.00	-31.1	-68.0	PEAK	V	-57.0	-11.1	PASS
7424.00	-34.3	-71.3	PEAK	H	-57.0	-14.3	PASS

**Tx Frequency: 928 MHz
 Transmitter Radiated Emissions Measurements at 3 meters OFTS**

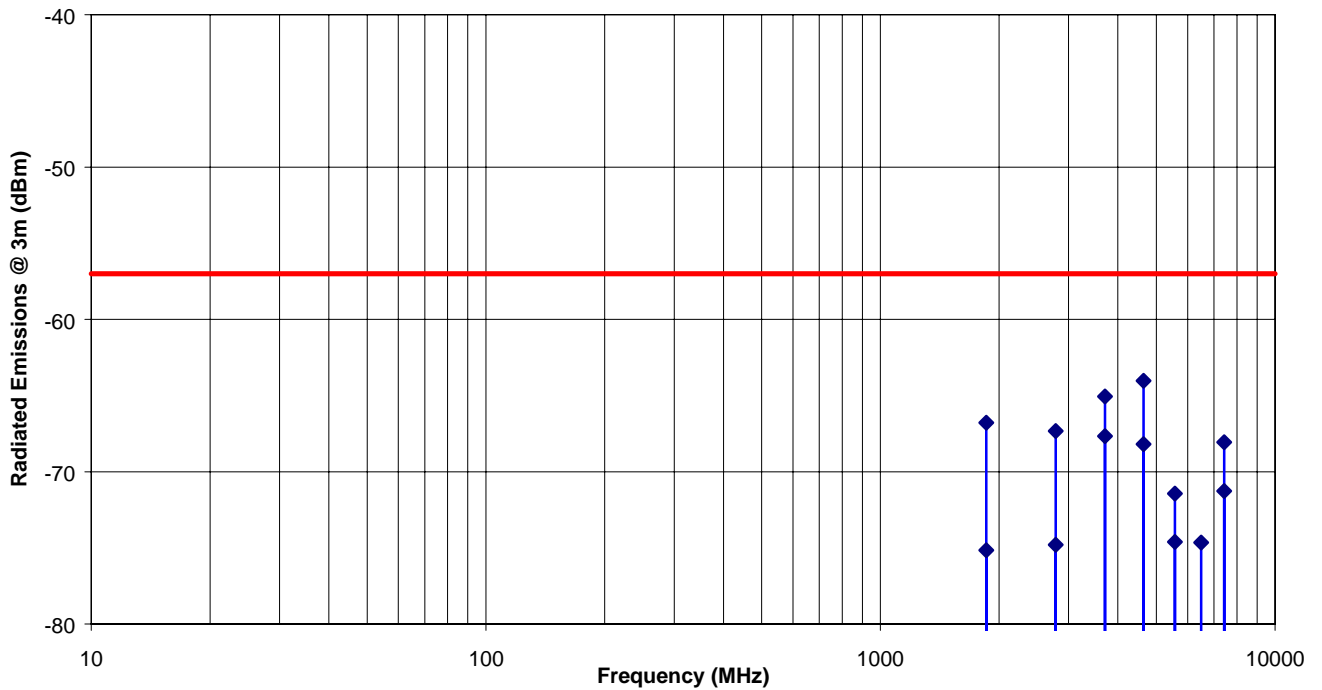

ULTRATECH GROUP OF LABS

3000 Bristol Circle, Oakville, Ontario, Canada L6H 6G4
 Tel. #: 905-829-1570, Fax. #: 905-829-8050, Email: vhk.ultratech@sympatico.ca, Website: http://www.ultratech-labs.com

File #: MIC42_TX
 July 10, 2001

- Assessed by ITI (UK) Competent Body, NVLAP (USA) Accreditation Body & ACA/AUSTEL (Australia)
- Accredited by Industry Canada (Canada) under ACC-LAB (Europe/Canada MRA)
- Recognized/Listed by FCC (USA)

All test results contained in this engineering test report are traceable to National Institute of Standards and Technology (NIST)

6.9.5.2. Near Middle Frequency (944 MHz)

RF POWER OUTPUT: 37 dBm

FREQUENCY (MHz)	Substitution Method		DETECTOR USED (PEAK/QP)	ANTENNA PLANE (H/V)	ERP Limit (dBc)	MARGIN (dB)	PASS/ FAIL
	ERP (dBm)	ERP (dBc)					
1888.00	-37.8	-74.8	PEAK	V	-57.0	-17.8	PASS
1888.00	-39.2	-76.2	PEAK	H	-57.0	-19.2	PASS
2832.00	-31.3	-68.3	PEAK	V	-57.0	-11.3	PASS
2832.00	-35.2	-72.2	PEAK	H	-57.0	-15.2	PASS
3776.00	-26.3	-63.3	PEAK	V	-57.0	-6.3	PASS
3776.00	-24.7	-61.7	PEAK	H	-57.0	-4.7	PASS
4720.00	-24.6	-61.6	PEAK	V	-57.0	-4.6	PASS
4720.00	-27.3	-64.3	PEAK	H	-57.0	-7.3	PASS
5664.00	-34.2	-71.2	PEAK	V	-57.0	-14.2	PASS
5664.00	-37.3	-74.2	PEAK	H	-57.0	-17.3	PASS
6608.00	-40.8	-77.8	PEAK	V	-57.0	-20.8	PASS
6608.00	-40.6	-77.6	PEAK	H	-57.0	-20.6	PASS
7552.00	-31.8	-68.8	PEAK	V	-57.0	-11.8	PASS
7552.00	-30.5	-67.5	PEAK	H	-57.0	-10.5	PASS

The emissions were scanned from 10 MHz to 10 GHz and all emissions within 20 dB below the limits were recorded.

Tx Frequency: 944 MHz

Transmitter Radiated Emissions Measurements at 3 meters OFTS

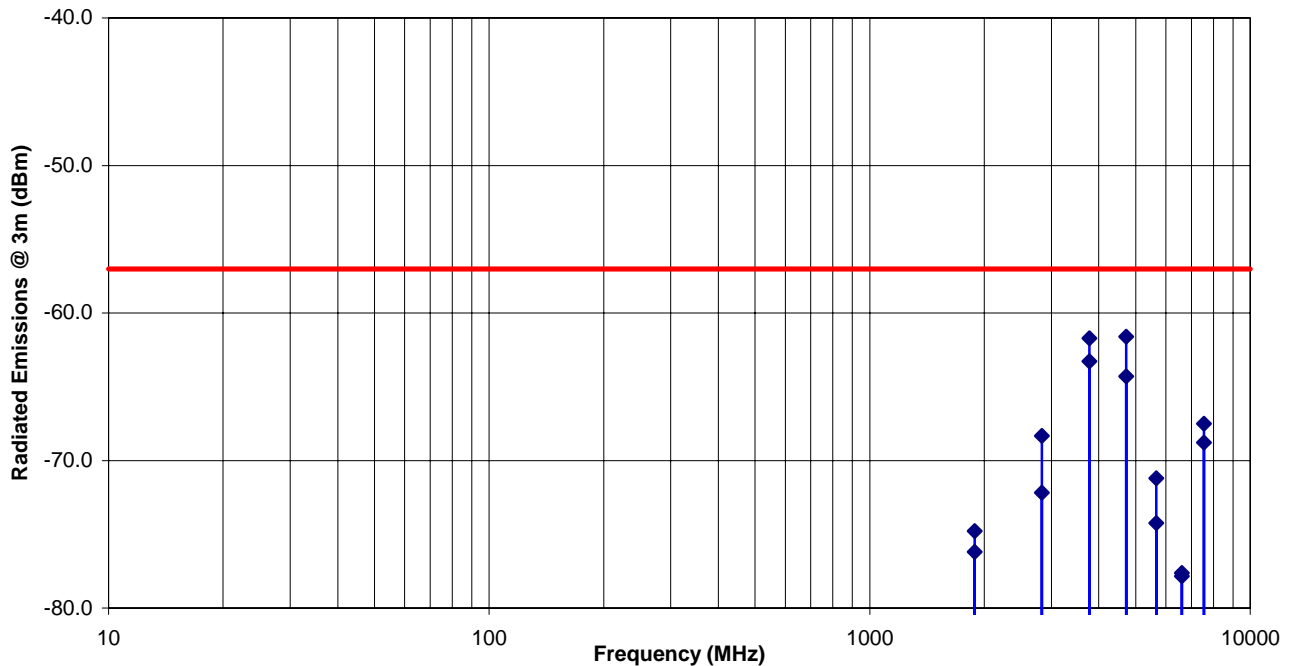

ULTRATECH GROUP OF LABS

3000 Bristol Circle, Oakville, Ontario, Canada L6H 6G4
 Tel. #: 905-829-1570, Fax. #: 905-829-8050, Email: vhk.ultratech@sympatico.ca, Website: http://www.ultratech-labs.com

File #: MIC42_TX
 July 10, 2001

- Assessed by ITI (UK) Competent Body, NVLAP (USA) Accreditation Body & ACA/AUSTEL (Australia)
- Accredited by Industry Canada (Canada) under ACC-LAB (Europe/Canada MRA)
- Recognized/Listed by FCC (USA)

All test results contained in this engineering test report are traceable to National Institute of Standards and Technology (NIST)

6.9.5.3. Near Highest Frequency (960 MHz)

RF POWER OUTPUT: 37 dBm

FREQUENCY (MHz)	Substitution Method		DETECTOR USED (PEAK/QP)	ANTENNA PLANE (H/V)	ERP Limit (dBc)	MARGIN (dB)	PASS/ FAIL
	ERP (dBm)	ERP (dBc)					
2880	-26.0	-63.0	PEAK	V	-57.0	-6.0	PASS
2880	-33.5	-70.5	PEAK	H	-57.0	-13.5	PASS
3840	-21.6	-58.6	PEAK	V	-57.0	-1.6	PASS
3840	-21.8	-58.8	PEAK	H	-57.0	-1.8	PASS
4800	-23.0	-60.0	PEAK	V	-57.0	-3.0	PASS
4800	-26.9	-63.9	PEAK	H	-57.0	-6.9	PASS
5760	-33.7	-70.7	PEAK	V	-57.0	-13.7	PASS
5760	-32.7	-69.7	PEAK	H	-57.0	-12.7	PASS
6720	-37.9	-74.9	PEAK	V	-57.0	-17.9	PASS
7680	-27.9	-64.9	PEAK	V	-57.0	-7.9	PASS
7680	-33.1	-70.1	PEAK	H	-57.0	-13.1	PASS
8640	-30.9	-67.9	PEAK	V	-57.0	-10.9	PASS
8640	-31.7	-68.7	PEAK	H	-57.0	-11.7	PASS

The emissions were scanned from 10 MHz to 10 GHz and all emissions within 20 dB below the limits were recorded.

Tx Frequency: 960 MHz

Transmitter Radiated Emissions Measurements at 3 meters OFTS

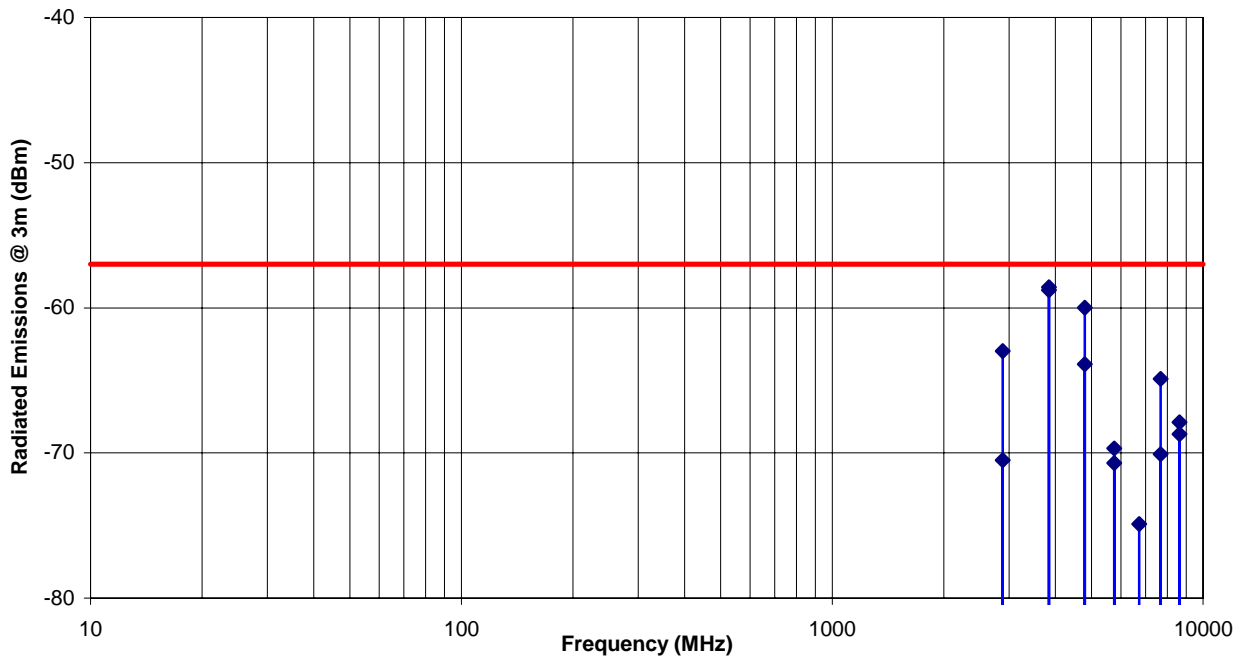

ULTRATECH GROUP OF LABS

3000 Bristol Circle, Oakville, Ontario, Canada L6H 6G4
 Tel. #: 905-829-1570, Fax. #: 905-829-8050, Email: vhk.ultratech@sympatico.ca, Website: http://www.ultratech-labs.com

File #: MIC42_TX
 July 10, 2001

- Assessed by ITI (UK) Competent Body, NVLAP (USA) Accreditation Body & ACA/AUSTEL (Australia)
 - Accredited by Industry Canada (Canada) under ACC-LAB (Europe/Canada MRA)
 - Recognized/Listed by FCC (USA)
- All test results contained in this engineering test report are traceable to National Institute of Standards and Technology (NIST)

6.10. FREQUENCY STABILITY @ FCC 2.1055 & 101.107

6.10.1. Limits

Please refer to FCC 47 CFR, Part 101.107 and the following summary:

FREQUENCY RANGE (MHz)	Paragraph 101.107 (ppm)
928-929 ^(2,5)	5
932-932.5 ⁽²⁾	1.5
932.5-935 ⁽²⁾	2.5
941-941.5	1.5
941.5-944	2.5
952-960 (12.5 kHz Bandwidth)	1.5
944-1000	5

Note 2: Equipment authorized to be operated on frequencies between 890 and 940 MHz as of Oct. 15, 1996, must maintain a frequency tolerance within 0.03 percent subject to the conditions that no harmful interference is caused to any other radio station.

Note 5: For remote stations with 12.5 kHz bandwidth, tolerance is ± 0.00015 percent.

6.10.2. Method of Measurements

Refer to FCC 47 CFR, Part 2.1055 and Exhibit 8, Sec. 8.2 of this report for detailed test procedures.

6.10.3. Test Equipment List

Test Instruments	Manufacturer	Model No.	Serial No.	Frequency Range
Spectrum Analyzer/EMI Receiver	Advantest	R3271	15050203	100 Hz – 26.5 GHz
Attenuator(s)	Bird	DC – 22 GHz
Temperature & Humidity Chamber	Tenney	T5	9723B	-40° to +60° C range

6.10.4. Test Arrangement

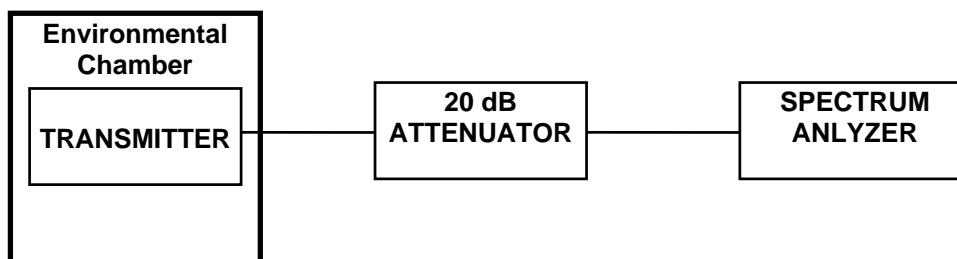

ULTRATECH GROUP OF LABS

3000 Bristol Circle, Oakville, Ontario, Canada L6H 6G4
 Tel. #: 905-829-1570, Fax. #: 905-829-8050, Email: vhk.ultratech@sympatico.ca, Website: <http://www.ultratech-labs.com>

File #: MIC42_TX
 July 10, 2001

- Assessed by ITI (UK) Competent Body, NVLAP (USA) Accreditation Body & ACA/AUSTEL (Australia)
- Accredited by Industry Canada (Canada) under ACC-LAB (Europe/Canada MRA)
- Recognized/Listed by FCC (USA)

All test results contained in this engineering test report are traceable to National Institute of Standards and Technology (NIST)

6.10.5. Test Data

Frequency Band:	928-960
Test Frequency:	928 MHz
Full Power Level:	5 Watts or 37 dBm
Frequency Tolerance Limit:	1.5 ppm or 1392 Hz
Max. Frequency Tolerance Measured:	-417 Hz (0.45 ppm)
Input Voltage Rating:	13.8 Vdc nominal

TEST FREQUENCY & RF POWER OUTPUT VARIATION						
Ambient Temp (°C)	Supply Voltage (Nominal) 13.8Volts		Supply Voltage (85% of Nominal) 11.7Volts		Supply Voltage (115% of Nominal) 15.9 Volts	
	Hz	dB	Hz	dB	Hz	dB
-30	-360	N/A	N/A	N/A	N/A	N/A
-20	+299	N/A	N/A	N/A	N/A	N/A
-10	+169	N/A	N/A	N/A	N/A	N/A
0	+42	N/A	N/A	N/A	N/A	N/A
+10	+92	N/A	N/A	N/A	N/A	N/A
+20	-27	0.5	-37	-0.2	-49	-0.3
+30	-96	N/A	N/A	N/A	N/A	N/A
+40	-66	N/A	N/A	N/A	N/A	N/A
+50	-417	N/A	N/A	N/A	N/A	N/A

ULTRATECH GROUP OF LABS

3000 Bristol Circle, Oakville, Ontario, Canada L6H 6G4
 Tel. #: 905-829-1570, Fax. #: 905-829-8050, Email: vhk.ultratech@sympatico.ca, Website: http://www.ultratech-labs.com

File #: MIC42_TX
July 10, 2001

- Assessed by ITI (UK) Competent Body, NVLAP (USA) Accreditation Body & ACA/AUSTEL (Australia)
- Accredited by Industry Canada (Canada) under ACC-LAB (Europe/Canada MRA)
- Recognized/Listed by FCC (USA)

All test results contained in this engineering test report are traceable to National Institute of Standards and Technology (NIST)

EXHIBIT 7. MEASUREMENT UNCERTAINTY

The measurement uncertainties stated were calculated in accordance with the requirements of NIST Technical Note 1297 and NIS 81 (1994)

7.1. RADIATED EMISSION MEASUREMENT UNCERTAINTY

CONTRIBUTION (Radiated Emissions)	PROBABILITY DISTRIBUTION	UNCERTAINTY (\pm dB)	
		3 m	10 m
Antenna Factor Calibration	Normal (k=2)	± 1.0	± 1.0
Cable Loss Calibration	Normal (k=2)	± 0.3	± 0.5
EMI Receiver specification	Rectangular	± 1.5	± 1.5
Antenna Directivity	Rectangular	+0.5	+0.5
Antenna factor variation with height	Rectangular	± 2.0	± 0.5
Antenna phase center variation	Rectangular	0.0	± 0.2
Antenna factor frequency interpolation	Rectangular	± 0.25	± 0.25
Measurement distance variation	Rectangular	± 0.6	± 0.4
Site imperfections	Rectangular	± 2.0	± 2.0
Mismatch: Receiver VRC $\Gamma_1 = 0.2$ Antenna VRC $\Gamma_R = 0.67$ (Bi) 0.3 (Lp) Uncertainty limits $20\text{Log}(1 \pm \Gamma_1 \Gamma_R)$	U-Shaped	+1.1 -1.25	± 0.5
System repeatability	Std. Deviation	± 0.5	± 0.5
Repeatability of EUT		-	-
Combined standard uncertainty	Normal	+2.19 / -2.21	+1.74 / -1.72
Expanded uncertainty U	Normal (k=2)	+4.38 / -4.42	+3.48 / -3.44

Calculation for maximum uncertainty when 3m biconical antenna including a factor of k=2 is used:

$$U = 2u_c(y) = 2x(+2.19) = +4.38 \text{ dB} \quad \text{And} \quad U = 2u_c(y) = 2x(-2.21) = -4.42 \text{ dB}$$

ULTRATECH GROUP OF LABS

3000 Bristol Circle, Oakville, Ontario, Canada L6H 6G4
 Tel. #: 905-829-1570, Fax. #: 905-829-8050, Email: vhk.ultratech@sympatico.ca, Website: http://www.ultratech-labs.com

File #: MIC42_TX
 July 10, 2001

- Assessed by ITI (UK) Competent Body, NVLAP (USA) Accreditation Body & ACA/AUSTEL (Australia)
- Accredited by Industry Canada (Canada) under ACC-LAB (Europe/Canada MRA)
- Recognized/Listed by FCC (USA)

All test results contained in this engineering test report are traceable to National Institute of Standards and Technology (NIST)

EXHIBIT 8. MEASUREMENT METHODS

8.1. EFFECTIVE RADIATED POWER (ERP) MEASUREMENTS

- The following shall be applied to the combination(s) of the radio device and its intended antenna(e).
- If the RF level is user adjustable, all measurements shall be made with the highest power level available to the user for that combination.
- The following method of measurement shall apply to both conducted and radiated measurements.
- The radiated measurements are performed at the UltraTech Calibrated Open Field Test Site.
- The measurement shall be performed using normal operation of the equipment with modulation.

Test procedure shall be as follows:

Step 1: Duty Cycle measurements

- Using a spectrum analyzer with the frequency span set to 0 Hz and the sweep time set at a suitable value to capture the envelope peaks and the duty cycle of the transmitter output signal;
- The duty cycle of the transmitter, $x = \text{Tx on} / (\text{Tx on} + \text{Tx off})$ with $0 < x < 1$, is measure and recorded in the test report. For the purpose of testing, the equipment shall be operated with a duty cycle that is equal or more than 0.1.

Step 2: Calculation of Average EIRP. See Figure 1

- The average output power of the transmitter shall be determined using a wideband, calibrated RF power meter with the power sensor with an integration period that exceeds the repetition period of the transmitter by a factor 5 or more. The observed value shall be recorded as “A” (in dBm);
- The e.i.r.p. shall be calculated from the above measured power output “A”, the observed duty cycle x , and the applicable antenna assembly gain “G” in dBi, according to the formula:

$$\text{EIRP} = A + G + 10\log(1/x)$$

Figure 1.

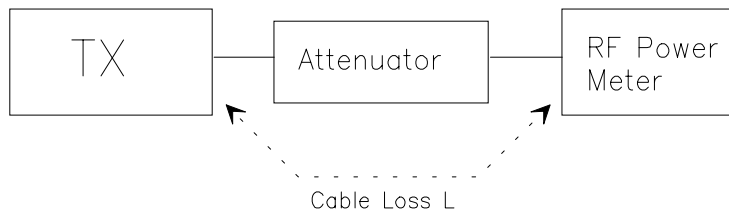

Step 3: Substitution Method. See Figure 2

- (a) The setting of the spectrum analyzer shall be:

Center Frequency:	equal to the signal source
Resolution BW:	100 kHz for narrow band signal and 1 MHz for broadband signal
Video BW:	same
Detector Mode:	positive
Average:	off
Span:	3 x the signal bandwidth

ULTRATECH GROUP OF LABS

3000 Bristol Circle, Oakville, Ontario, Canada L6H 6G4
Tel. #: 905-829-1570, Fax. #: 905-829-8050, Email: vhk.ultratech@sympatico.ca, Website: <http://www.ultratech-labs.com>

File #: MIC42_TX
July 10, 2001

- Assessed by ITI (UK) Competent Body, NVLAP (USA) Accreditation Body & ACA/AUSTEL (Australia)
- Accredited by Industry Canada (Canada) under ACC-LAB (Europe/Canada MRA)
- Recognized/Listed by FCC (USA)

All test results contained in this engineering test report are traceable to National Institute of Standards and Technology (NIST)

- (b) Perform tests at listed 3m open area test site (listed with FCC, IC, ITI, NVLAP, ACA & VCCI).
- (c) The transmitter under test was placed at the specified height on a non-conducting turntable (80 cm height)
- (d) Tune the dipole test antenna to the transmitter carrier frequency.
- (e) Load an appropriate correction factors files in Spectrum Analyzer #1 for correcting the field strength reading level (E = reading + cable loss + Antenna factor)
- (f) Load an appropriate correction files in Spectrum Analyzer #2 to correct the EIRP reading which is pre-calibrated.
- (g) Tune the spectrum analyzers # 1 & # 2 to transmitter carrier frequency.
- (h) Lower or raise the test antenna from 1 to 4 meters until the maximum signal level was detected.
- (i) The transmitter was rotated through 360° about a vertical axis until a higher maximum signal was received.
- (j) Lower or raise the test antenna from 1 to 4 meters until the maximum signal level was detected.
- (k) Again, lowered or raised the test antenna from 1 to 4 meters to ensure the position where the maximum E-field was read . Record E-field level.
- (l) Substitute the dipole antenna and the signal generator with the EUT at the same location.
- (m) Adjust the substitution antenna at 1.5 meter high from the ground plane.
- (n) Placed the dipole antenna in vertical polarization.
- (o) Lower or raise as necessary to ensure that the maximum signal is still received.
- (p) Adjust input signal to the substitution antenna until an equal or a known related level to that detected from the transmitter was obtained in the test receiver.
- (q) The EIRP power was read in the spectrum analyzer #2 (this reading was already corrected by our pre-calibrated values as follows:

Frequency (MHz)	Cable+Combiner Loss L2 For Port #2 (dB)	Cable+Combiner Loss L1 For Port # 1 (dB)	Total Corr. (L2-L1) for S/G Power (P) (dB)	DIPOLE ANTENNA S/N:8907-440 Gain G1 (dBi)	DIPOLE ELEMENT
100	-7.0	-7.8	0.8	1.0	DB-2
120	-7.0	-8.0	1.0	1.0	DB-2
140	-7.0	-8.1	1.1	1.9	DB-2
160	-7.0	-7.9	0.9	1.4	DB-3
180	-7.2	-7.9	0.7	1.8	DB-3
200	-7.1	-8.0	0.9	1.9	DB-3
250	-7.1	-8.1	1.1	0.9	DB-3
300	-7.1	-8.4	1.4	1.7	DB-3
350	-7.2	-8.5	1.4	2.8	DB-3
400	-7.3	-8.8	1.5	0.3	DB-3
450	-7.3	-8.7	1.4	1.2	DB-4
500	-7.2	-9.0	1.8	0.8	DB-4
550	-7.4	-9.0	1.6	0.9	DB-4
600	-7.3	-8.9	1.5	0.4	DB-4
650	-7.3	-9.3	2.0	1.3	DB-4
700	-7.4	-9.4	2.0	0.8	DB-4
750	-7.5	-9.6	2.1	2.0	DB-4
800	-7.4	-9.5	2.1	2.0	DB-4
850	-7.4	-9.8	2.3	1.0	DB-4
900	-7.5	-9.7	2.2	2.0	DB-4
950	-7.5	-10.0	2.5	2.4	DB-4
1000	-7.6	-10.0	2.4	0.6	DB-4

ULTRATECH GROUP OF LABS

3000 Bristol Circle, Oakville, Ontario, Canada L6H 6G4
 Tel. #: 905-829-1570, Fax. #: 905-829-8050, Email: vhk.ultratech@sympatico.ca, Website: http://www.ultratech-labs.com

File #: MIC42_TX
 July 10, 2001

- Assessed by ITI (UK) Competent Body, NVLAP (USA) Accreditation Body & ACA/AUSTEL (Australia)
- Accredited by Industry Canada (Canada) under ACC-LAB (Europe/Canada MRA)
- Recognized/Listed by FCC (USA)

All test results contained in this engineering test report are traceable to National Institute of Standards and Technology (NIST)

Frequency (MHz)	Cable+Combiner Loss L2 For Port #2 (dB)	Cable+Combiner Loss L1 For Port # 1 (dB)	Total Corr. (L2-L1) for S/G Power (P) (dB)	E 3115 Horn S/N: 9911-5955 Gain G1 (dBi)
1500	-7.9	-11.0	3.1	8.8
2000	-8.3	-11.7	3.4	9.0
2500	-8.4	-12.0	3.6	9.3
3000	-8.7	-13.0	4.4	9.0
3500	-8.8	-13.4	4.6	8.1
4000	-9.4	-15.5	6.2	9.6
4500	-9.6	-17.4	7.9	11.3
5000	-9.3	-17.5	8.1	10.7
5500	-9.9	-20.1	10.2	10.3
6000	-10.3	-20.2	9.9	10.5
6500	-10.5	-22.5	12.0	11.3
7000	-10.2	-22.9	12.7	11.2
7500	-10.3	-24.0	13.7	10.8
8000	-10.5	-20.4	9.9	11.4
8500	-11.0	-18.8	7.8	11.0
9000	-10.7	-23.0	12.3	10.7
9500	-11.1	-21.5	10.4	11.5
10000	-11.4	-23.2	11.8	12.0
12000	-12.1	-29.4	17.3	12.9
14000	-11.7	-33.5	21.8	11.6
16000	-13.3	-28.1	14.8	16.0
18000	-14.2	-29.4	15.2	8.6

Note: Calculation of EIRP:

$$P = P1 - L1 = (P2 + L2) - L1 = P2 + (L2-L1)$$

$$EIRP = P + G1 = P2 + (L2-L1) + G1$$

$$ERP = EIRP - 2.15 \text{ dB}$$

$$\text{Correction factor in Spectrum Analyzer 2} = G1 + L2 - L1$$

Where: P: Actual RF Power fed into the substitution antenna port after corrected.
 P1: Power output from the signal generator
 P2: Power measured at spectrum analyzer #2
 EIRP: EIRP after correction
 ERP: ERP after correction

- (r) The substitution antenna gain and cable loss were added to the signal generator level for the corrected EIRP level.
- (s) Repeat steps (c) to (j) with the substitution antenna oriented in horizontal polarization.
- (t) Actual gain of the EUT's antenna is the difference of the measured EIRP and measured RF power at the RF port. Correct the antenna gain if necessary.

ULTRATECH GROUP OF LABS

3000 Bristol Circle, Oakville, Ontario, Canada L6H 6G4
 Tel. #: 905-829-1570, Fax. #: 905-829-8050, Email: vhk.ultratech@sympatico.ca, Website: http://www.ultratech-labs.com

File #: MIC42_TX
 July 10, 2001

- Assessed by ITI (UK) Competent Body, NVLAP (USA) Accreditation Body & ACA/AUSTEL (Australia)
- Accredited by Industry Canada (Canada) under ACC-LAB (Europe/Canada MRA)
- Recognized/Listed by FCC (USA)

All test results contained in this engineering test report are traceable to National Institute of Standards and Technology (NIST)

Figure 2

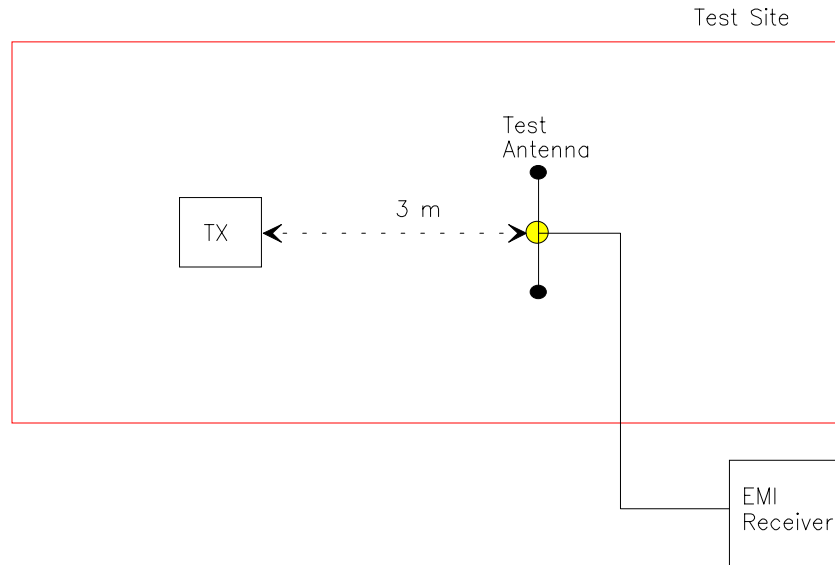
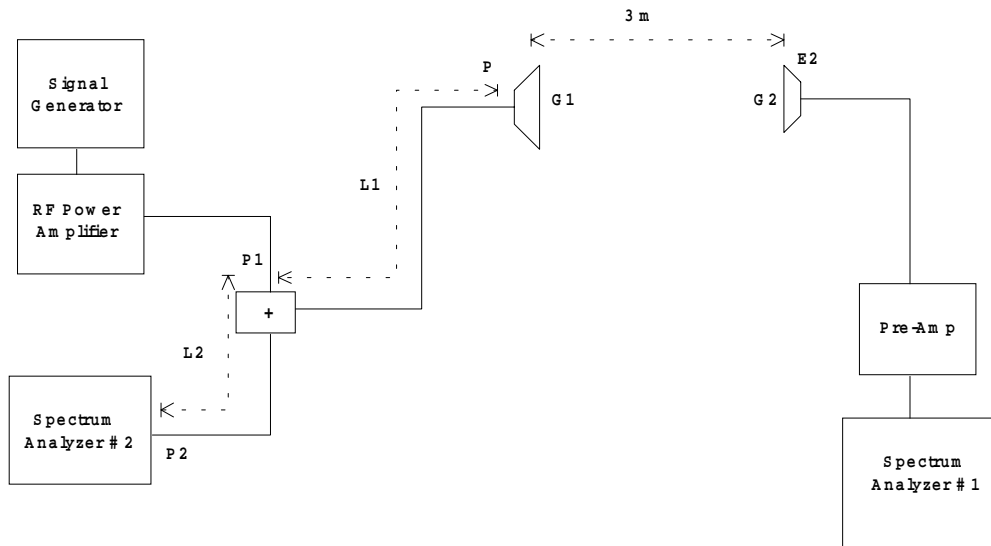

Figure 3



ULTRATECH GROUP OF LABS

3000 Bristol Circle, Oakville, Ontario, Canada L6H 6G4
Tel. #: 905-829-1570, Fax. #: 905-829-8050, Email: vhk.ultratech@sympatico.ca, Website: <http://www.ultratech-labs.com>

File #: MIC42_TX
July 10, 2001

- Assessed by ITI (UK) Competent Body, NVLAP (USA) Accreditation Body & ACA/AUSTEL (Australia)
- Accredited by Industry Canada (Canada) under ACC-LAB (Europe/Canada MRA)
- Recognized/Listed by FCC (USA)

All test results contained in this engineering test report are traceable to National Institute of Standards and Technology (NIST)

8.2. FREQUENCY STABILITY

Refer to FCC @ 2.1055

- (a) The frequency stability shall be measured with variation of ambient temperature as follows: From -30 to +50 centigrade except that specified in subparagraph (2) & (3) of this paragraph.
- (b) Frequency measurements shall be made at extremes of the specified temperature range and at intervals of not more than 10 centigrade through the range. A period of time sufficient to stabilize all of the components of the oscillator circuit at each temperature level shall be allowed prior to frequency measurement. The short term transient effects on the frequency of the transmitter due to keying (except for broadcast transmitters) and any heating element cycling normally occurring at each ambient temperature level also shall be shown. Only the portion or portions of the transmitter containing the frequency determining and stability circuitry need be subjected to the temperature variation test.
- (d) The frequency stability supply shall be measured with variation of primary supply voltage as follows:
 - (1) Vary primary supply voltage from 85 to 115 percent of the nominal value for other than hand carried battery equipment.
 - (2) For hand carried, battery powered equipment, reduce primary supply voltage to the battery operating end point which shall be specified by the manufacturer.
 - (3) The supply voltage shall be measured at the input to the cable normally provide with the equipment, or at the power supply terminals if cables are not normally provided. Effects on frequency of transmitter keying (except for broadcast transmitters) and any heating element cycling at the nominal supply voltage and at each extreme also shall be shown.
- (e) When deemed necessary, the Commission may require tests of frequency stability under conditions in addition to those specifically set out in paragraphs (a), (b), (c) and (d) of this section. (For example, measurements showing the effect of proximity to large metal objects, or of various types of antennas, may be required for portable equipment).

ULTRATECH GROUP OF LABS

3000 Bristol Circle, Oakville, Ontario, Canada L6H 6G4
Tel. #: 905-829-1570, Fax. #: 905-829-8050, Email: vhk.ultratech@sympatico.ca, Website: <http://www.ultratech-labs.com>

File #: MIC42_TX
July 10, 2001

- Assessed by ITI (UK) Competent Body, NVLAP (USA) Accreditation Body & ACA/AUSTEL (Australia)
- Accredited by Industry Canada (Canada) under ACC-LAB (Europe/Canada MRA)
- Recognized/Listed by FCC (USA)

All test results contained in this engineering test report are traceable to National Institute of Standards and Technology (NIST)

8.3. EMISSION MASK

Voice or Digital Modulation Through a Voice Input Port @ 2.1049(c)(1):- The transmitter was modulated by a 2.5 KHz tone signal at an input level 16 dB greater than that required to produce 50% modulation (e.g.: ± 2.5 KHz peak deviation at 1 KHz modulating frequency). The input level was established at the frequency of maximum response of the audio modulating circuit.

Digital Modulation Through a Data Input Port @ 2.1049(h):- Transmitters employing digital modulation techniques - when modulated by an input signal such that its amplitude and symbol rate represent the maximum rated conditions under which the equipment will be operated. The signal shall be applied through any filter networks, pseudo-random generators or other devices required in normal service. Additionally, the Emission Masks shall be shown for operation with any devices used for modifying the spectrum when such devices are operational at the discretion of the user.

The following spectrum analyzer bandwidth shall be used for measurement of spurious emissions:

- (1) When operating in the radio telephony mode or the supervisory audio Tone mode:
 - (i) Any emission not more than 45 kHz removed from the carrier frequency: 300 Hz.
 - (ii) Any emission more than 45 kHz removed from the carrier frequency: 30 kHz.
- (2) When operating in the wideband data mode or the signaling tone mode:
 - (iii) Any emission not more than 60 kHz removed from the carrier frequency: 300 Hz.
 - (iv) Any emission more than 60 kHz removed from the carrier frequency: 30 kHz.

In all cases the Video Bandwidth shall be equal or greater than the measuring bandwidth.

8.4. SPURIOUS EMISSIONS (CONDUCTED)

With transmitter modulation characteristics described in Out-of-Band Emissions measurements @ 2.989, the transmitter spurious and harmonic emissions were scanned. The spurious and harmonic emissions were measured with the Spectrum Analyzer controls set as RBW = 30 kHz minimum , VBW \geq RBW and SWEEP TIME = AUTO). The transmitter was operated at a full rated power output, and modulated as follows:

FCC CFR 47, Para. 2.1057 - Frequency spectrum to be investigated:- The spectrum was investigated from the lowest radio generated in the equipment up to at least the 10th harmonic of the carrier frequency or to the highest frequency practicable in the present state of the art of measuring techniques, whichever is lower. Particular attention should be paid to harmonics and sub-harmonics of the carrier frequency. Radiation at the frequencies of multiplier stages should be checked. The amplitude of spurious emissions which are attenuated more than 20 dB below the permissible value need not be reported.

FCC CFR 47, Para. 2.1051 - Spurious Emissions at Antenna Terminal:- The radio frequency voltage or powers generated within the equipment and appearing on a spurious frequency shall be checked at the equipment output terminals when properly loaded with a suitable artificial antenna. Curves or equivalent data shall show the magnitude of the harmonic and other spurious emission that can be detected when the equipment is operated under the conditions specified in 2.989 as appropriate. The magnitude of spurious emissions which are attenuated more than 20 dB below the permissible value need not be specified.

ULTRATECH GROUP OF LABS

3000 Bristol Circle, Oakville, Ontario, Canada L6H 6G4
Tel. #: 905-829-1570, Fax. #: 905-829-8050, Email: vhk.ultratech@sympatico.ca, Website: <http://www.ultratech-labs.com>

File #: MIC42_TX
July 10, 2001

- Assessed by ITI (UK) Competent Body, NVLAP (USA) Accreditation Body & ACA/AUSTEL (Australia)
- Accredited by Industry Canada (Canada) under ACC-LAB (Europe/Canada MRA)
- Recognized/Listed by FCC (USA)

All test results contained in this engineering test report are traceable to National Institute of Standards and Technology (NIST)

8.5. SPURIOUS EMISSIONS (RADIATED)

With transmitter modulation characteristics described in Out-of-Band Emissions measurements @ 2.1049, the transmitter spurious and harmonic emissions were scanned. The spurious and harmonic emissions were measured with the Spectrum Analyzer controls set as RBW = 100 kHz minimum , VBW \geq RBW and SWEEP TIME = AUTO). The transmitter was operated at a full rated power output and modulation, tested using the following procedure:

8.5.1. Maximizing RF Emission Level

- (a) The measurements was performed with standard modulation
- (b) Test was performed at listed 3m open area test site (listed with FCC, IC, ITI, NVLAP, ACA & VCCI).
- (c) The transmitter under test was placed at the specified height on a non-conducting turntable (80 cm height)
- (d) The Biconilog Antenna (20 MHz to 1 GHz) or Horn Antenna (1 GHz to 18 GHz) was used for measuring.
- (e) The spectrum analyzer was tuned to transmitter carrier frequency. The test antenna was lowered or raised from 1 to 4 meters until the maximum signal level was detected.
- (f) The transmitter was rotated through 360° about a vertical axis until a higher maximum signal was received.
- (g) The test antenna was lowered or raised again from 1 to 4 meters until a maximum was obtained. This level was recorded.
- (h) The recorded reading was corrected to the true field strength level by adding the antenna factor, cable loss and subtracting the pre-amplifier gain.
- (i) Repeat the step (d) to (h) for different test frequencies

8.5.2. Measuring the EIRP of Spurious/Harmonic Emissions using Substitution Method

- (a) Start from the list of the Field strength level obtain in Sec. 8.5.1
- (b) Substitute the EUT by a signal generator with the RF output connected to a dipole/horn antenna {use dipole antenna for frequency from 30-1000 MHz} and use horn antenna for frequency above 1 GHz }.
- (c) For frequencies less than or equal 1000 MHz, replace the test receiving antenna by a dipole antenna
- (d) Setup the substitution EIRP measurements as follows (only use the RF Power AMP if necessary):
- (e) For frequencies less than or equal 1000 MHz, replace the test receiving antenna by a dipole antenna
- (f) Apply the test setup and test method in Step 3 of Section 8.1 for EIRP of the spurious/harmonic emissions measurements with the following settings of both spectrum analyzer # 1 and 2

Center Frequency: equal to the signal source
Resolution BW: 10 kHz
Video BW: same
Detector Mode: positive
Average: off
Span: 3 x the signal bandwidth

ULTRATECH GROUP OF LABS

3000 Bristol Circle, Oakville, Ontario, Canada L6H 6G4
Tel. #: 905-829-1570, Fax. #: 905-829-8050, Email: vhk.ultratech@sympatico.ca, Website: <http://www.ultratech-labs.com>

File #: MIC42_TX
July 10, 2001

- Assessed by ITI (UK) Competent Body, NVLAP (USA) Accreditation Body & ACA/AUSTEL (Australia)
- Accredited by Industry Canada (Canada) under ACC-LAB (Europe/Canada MRA)
- Recognized/Listed by FCC (USA)

All test results contained in this engineering test report are traceable to National Institute of Standards and Technology (NIST)

ANNEX A. PLOTS OF MEASUREMENT DATA

ULTRATECH GROUP OF LABS

3000 Bristol Circle, Oakville, Ontario, Canada L6H 6G4
Tel. #: 905-829-1570, Fax. #: 905-829-8050, Email: vhk.ultratech@sympatico.ca, Website: <http://www.ultratech-labs.com>

File #: MIC42_TX
July 10, 2001

- Assessed by ITI (UK) Competent Body, NVLAP (USA) Accreditation Body & ACA/AUSTEL (Australia)
- Accredited by Industry Canada (Canada) under ACC-LAB (Europe/Canada MRA)
- Recognized/Listed by FCC (USA)

All test results contained in this engineering test report are traceable to National Institute of Standards and Technology (NIST)

ANNEX B. PHOTOGRAPHS OF TEST SETUP

ULTRATECH GROUP OF LABS

3000 Bristol Circle, Oakville, Ontario, Canada L6H 6G4

Tel. #: 905-829-1570, Fax. #: 905-829-8050, Email: vhk.ultratech@sympatico.ca, Website: <http://www.ultratech-labs.com>

File #: MIC42_TX
July 10, 2001

- Assessed by ITI (UK) Competent Body, NVLAP (USA) Accreditation Body & ACA/AUSTEL (Australia)
- Accredited by Industry Canada (Canada) under ACC-LAB (Europe/Canada MRA)
- Recognized/Listed by FCC (USA)

All test results contained in this engineering test report are traceable to National Institute of Standards and Technology (NIST)

ANNEX C. EXTERNAL PHOTOGRAPHS OF EUT

ULTRATECH GROUP OF LABS

3000 Bristol Circle, Oakville, Ontario, Canada L6H 6G4
Tel. #: 905-829-1570, Fax. #: 905-829-8050, Email: vhk.ultratech@sympatico.ca, Website: <http://www.ultratech-labs.com>

File #: MIC42_TX
July 10, 2001

- Assessed by ITI (UK) Competent Body, NVLAP (USA) Accreditation Body & ACA/AUSTEL (Australia)
- Accredited by Industry Canada (Canada) under ACC-LAB (Europe/Canada MRA)
- Recognized/Listed by FCC (USA)

All test results contained in this engineering test report are traceable to National Institute of Standards and Technology (NIST)

ANNEX D. INTERNAL PHOTOGRAPHS OF EUT

ULTRATECH GROUP OF LABS

3000 Bristol Circle, Oakville, Ontario, Canada L6H 6G4

Tel. #: 905-829-1570, Fax. #: 905-829-8050, Email: vhk.ultratech@sympatico.ca, Website: <http://www.ultratech-labs.com>

File #: MIC42_TX
July 10, 2001

- Assessed by ITI (UK) Competent Body, NVLAP (USA) Accreditation Body & ACA/AUSTEL (Australia)
- Accredited by Industry Canada (Canada) under ACC-LAB (Europe/Canada MRA)
- Recognized/Listed by FCC (USA)

All test results contained in this engineering test report are traceable to National Institute of Standards and Technology (NIST)

ANNEX E. COVER LETTERS

ULTRATECH GROUP OF LABS

3000 Bristol Circle, Oakville, Ontario, Canada L6H 6G4

Tel. #: 905-829-1570, Fax. #: 905-829-8050, Email: vhk.ultratech@sympatico.ca, Website: <http://www.ultratech-labs.com>

File #: MIC42_TX
July 10, 2001

- Assessed by ITI (UK) Competent Body, NVLAP (USA) Accreditation Body & ACA/AUSTEL (Australia)
- Accredited by Industry Canada (Canada) under ACC-LAB (Europe/Canada MRA)
- Recognized/Listed by FCC (USA)

All test results contained in this engineering test report are traceable to National Institute of Standards and Technology (NIST)

ANNEX F. USERS MANUAL

ULTRATECH GROUP OF LABS

3000 Bristol Circle, Oakville, Ontario, Canada L6H 6G4

Tel. #: 905-829-1570, Fax. #: 905-829-8050, Email: vhk.ultratech@sympatico.ca, Website: <http://www.ultratech-labs.com>

File #: MIC42_TX
July 10, 2001

- Assessed by ITI (UK) Competent Body, NVLAP (USA) Accreditation Body & ACA/AUSTEL (Australia)
- Accredited by Industry Canada (Canada) under ACC-LAB (Europe/Canada MRA)
- Recognized/Listed by FCC (USA)

All test results contained in this engineering test report are traceable to National Institute of Standards and Technology (NIST)

ANNEX G. APPLICATION FORMS

ULTRATECH GROUP OF LABS

3000 Bristol Circle, Oakville, Ontario, Canada L6H 6G4
Tel. #: 905-829-1570, Fax. #: 905-829-8050, Email: vhk.ultratech@sympatico.ca, Website: <http://www.ultratech-labs.com>

File #: MIC42_TX
July 10, 2001

- Assessed by ITI (UK) Competent Body, NVLAP (USA) Accreditation Body & ACA/AUSTEL (Australia)
- Accredited by Industry Canada (Canada) under ACC-LAB (Europe/Canada MRA)
- Recognized/Listed by FCC (USA)

All test results contained in this engineering test report are traceable to National Institute of Standards and Technology (NIST)

ANNEX H. ID LABEL AND LOCATION INFORMATION

ULTRATECH GROUP OF LABS

3000 Bristol Circle, Oakville, Ontario, Canada L6H 6G4
Tel. #: 905-829-1570, Fax. #: 905-829-8050, Email: vhk.ultratech@sympatico.ca, Website: <http://www.ultratech-labs.com>

File #: MIC42_TX
July 10, 2001

- Assessed by ITI (UK) Competent Body, NVLAP (USA) Accreditation Body & ACA/AUSTEL (Australia)
- Accredited by Industry Canada (Canada) under ACC-LAB (Europe/Canada MRA)
- Recognized/Listed by FCC (USA)

All test results contained in this engineering test report are traceable to National Institute of Standards and Technology (NIST)

ANNEX I. BLOCK DIAGRAM

ULTRATECH GROUP OF LABS

3000 Bristol Circle, Oakville, Ontario, Canada L6H 6G4

Tel. #: 905-829-1570, Fax. #: 905-829-8050, Email: vhk.ultratech@sympatico.ca, Website: <http://www.ultratech-labs.com>

File #: MIC42_TX
July 10, 2001

- Assessed by ITI (UK) Competent Body, NVLAP (USA) Accreditation Body & ACA/AUSTEL (Australia)
- Accredited by Industry Canada (Canada) under ACC-LAB (Europe/Canada MRA)
- Recognized/Listed by FCC (USA)

All test results contained in this engineering test report are traceable to National Institute of Standards and Technology (NIST)

ANNEX J. SCHEMATIC DIAGRAMS

ULTRATECH GROUP OF LABS

3000 Bristol Circle, Oakville, Ontario, Canada L6H 6G4

Tel. #: 905-829-1570, Fax. #: 905-829-8050, Email: vhk.ultratech@sympatico.ca, Website: <http://www.ultratech-labs.com>

File #: MIC42_TX
July 10, 2001

- Assessed by ITI (UK) Competent Body, NVLAP (USA) Accreditation Body & ACA/AUSTEL (Australia)
- Accredited by Industry Canada (Canada) under ACC-LAB (Europe/Canada MRA)
- Recognized/Listed by FCC (USA)

All test results contained in this engineering test report are traceable to National Institute of Standards and Technology (NIST)

ANNEX K. PARTS LIST / TUNE UP INFORMATION

ULTRATECH GROUP OF LABS

3000 Bristol Circle, Oakville, Ontario, Canada L6H 6G4
Tel. #: 905-829-1570, Fax. #: 905-829-8050, Email: vhk.ultratech@sympatico.ca, Website: <http://www.ultratech-labs.com>

File #: MIC42_TX
July 10, 2001

- Assessed by ITI (UK) Competent Body, NVLAP (USA) Accreditation Body & ACA/AUSTEL (Australia)
- Accredited by Industry Canada (Canada) under ACC-LAB (Europe/Canada MRA)
- Recognized/Listed by FCC (USA)

All test results contained in this engineering test report are traceable to National Institute of Standards and Technology (NIST)

ANNEX L. OPERATIONAL DESCRIPTION

ULTRATECH GROUP OF LABS

3000 Bristol Circle, Oakville, Ontario, Canada L6H 6G4
Tel. #: 905-829-1570, Fax. #: 905-829-8050, Email: vhk.ultratech@sympatico.ca, Website: <http://www.ultratech-labs.com>

File #: MIC42_TX
July 10, 2001

- Assessed by ITI (UK) Competent Body, NVLAP (USA) Accreditation Body & ACA/AUSTEL (Australia)
- Accredited by Industry Canada (Canada) under ACC-LAB (Europe/Canada MRA)
- Recognized/Listed by FCC (USA)

All test results contained in this engineering test report are traceable to National Institute of Standards and Technology (NIST)