

ENGINEERING TEST REPORT

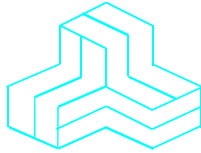

LEDR Microwave Radio
Model No.: LEDR 400S
FCC ID: E5M-LEDR400S

Applicant: **Microwave Data Systems Inc.**
175 Science Parkway
Rochester, New York
USA, 14620

Tested in Accordance With

Federal Communications Commission (FCC)
CFR 47, PARTS 2 and 90 (Subpart I)

UltraTech's File No.: MIC23-FTX

This Test report is Issued under the Authority of Tri M. Luu, Professional Engineer, Vice President of Engineering UltraTech Group of Labs	
Date:	
Report Prepared by: Dan Huynh	Tested by: Hung Trinh, EMI/RFI Technician
Issued Date: September 5, 2000	Test Dates: April 25 – May 4, August 25, 2000

The results in this Test Report apply only to the sample(s) tested, and the sample tested is randomly selected.

UltraTech

3000 Bristol Circle, Oakville, Ontario, Canada, L6H 6G4
Telephone (905) 829-1570 Facsimile (905) 829-8050

Website: www.ultratech-labs.com Email: vhk.ultratech@sympatico.ca

TABLE OF CONTENTS

EXHIBIT 1.	SUBMITTAL CHECK LIST	1
EXHIBIT 2.	INTRODUCTION.....	2
2.1.	SCOPE.....	2
2.2.	RELATED SUBMITAL(S)/GRANT(S)	2
2.3.	NORMATIVE REFERENCES.....	2
EXHIBIT 3.	PERFORMANCE ASSESSMENT	3
3.1.	CLIENT INFORMATION.....	3
3.2.	EQUIPMENT UNDER TEST (EUT) INFORMATION.....	3
3.3.	EUT'S TECHNICAL SPECIFICATIONS	4
3.4.	LIST OF EUT'S PORTS.....	4
EXHIBIT 4.	EUT OPERATING CONDITIONS AND CONFIGURATIONS DURING TESTS	5
4.1.	CLIMATE TEST CONDITIONS.....	5
4.2.	OPERATIONAL TEST CONDITIONS & ARRANGEMENT FOR TEST SIGNALS	5
EXHIBIT 5.	SUMMARY OF TEST RESULTS.....	6
5.1.	LOCATION OF TESTS	6
5.2.	APPLICABILITY & SUMMARY OF EMC EMISSION TEST RESULTS.....	6
5.3.	MODIFICATIONS INCORPORATED IN THE EUT FOR COMPLIANCE PURPOSES.....	6
EXHIBIT 6.	MEASUREMENTS, EXAMINATIONS & TEST DATA FOR EMC EMISSIONS.....	7
6.1.	TEST PROCEDURES	7
6.2.	MEASUREMENT UNCERTAINTIES	7
6.3.	MEASUREMENT EQUIPMENT USED:.....	7
6.4.	ESSENTIAL/PRIMARY FUNCTIONS AS DECLARED BY THE MANUFACTURER:.....	7
6.5.	RF POWER OUTPUT @ FCC 2.985 & 90.205	8
6.5.1.	<i>Limits @ FCC 90.205</i>	8
6.5.2.	<i>Method of Measurements</i>	8
6.5.3.	<i>Test Equipment List</i>	8
6.5.4.	<i>Test Arrangement</i>	8
6.5.5.	<i>Test Data</i>	8
6.6.	FREQUENCY STABILITY @ FCC 2.995 & 90.213.....	9
6.6.1.	<i>Limits @ FCC 90.213</i>	9
6.6.2.	<i>Method of Measurements</i>	9
6.6.3.	<i>Test Equipment List</i>	10
6.6.4.	<i>Test Arrangement</i>	10
6.6.5.	<i>Test Data</i>	10
6.7.	EMISSION MASK @ FCC 2.989, 90.208 & 90.210	17
6.7.1.	<i>Limits @ FCC 90.209 & 90.210</i>	17
6.7.2.	<i>Method of Measurements</i>	17
6.7.3.	<i>Test Equipment List</i>	17
6.7.4.	<i>Test Arrangement</i>	17
6.7.5.	<i>Test Data</i>	17

ULTRATECH GROUP OF LABS

3000 Bristol Circle, Oakville, Ontario, Canada L6H 6G4
Tel. #: 905-829-1570, Fax. #: 905-829-8050, Email: vhk.ultratech@sympatico.ca, Website: <http://www.ultratech-labs.com>

File #: MIC23-FTX
September 5, 2000

- Assessed by ITI (UK) Competent Body, NVLAP (USA) Accreditation Body & ACA/AUSTEL (Australia)
- Recognized/Listed by FCC (USA), Industry Canada (Canada)
- All test results contained in this engineering test report are traceable to National Institute of Standards and Technology (NIST)

6.8. TRANSMITTER ANTENNA POWER SPURIOUS/HARMONIC CONDUCTED EMISSIONS @ FCC 90.210..... 18
6.8.1. Limits @ 90.210..... 18
6.8.2. Method of Measurements..... 18
6.8.3. Test Equipment List..... 18
6.8.4. Test Arrangement..... 18
6.8.5. Test Data..... 19
6.9. TRANSMITTER SPURIOUS/HARMONIC RADIATED EMISSIONS @ FCC 90.210 20
6.9.1. Limits @ FCC 90.210 20
6.9.2. Method of Measurements..... 20
6.9.3. Test Equipment List..... 20
6.9.4. Test Arrangement..... 21
6.9.5. Test Data..... 22
6.9.6. Photographs of Test Setup 22
6.10. TRANSIENT FREQUENCY BEHAVIOR @ 90.214 23
6.10.1. Limits 23
6.10.2. Method of Measurements..... 23
6.10.3. Test Equipment List..... 23
6.10.4. Test Arrangement..... 24
6.10.5. Test Data..... 25
6.10.6. Plots 25
EXHIBIT 7. MEASUREMENT UNCERTAINTY 26
7.1. RADIATED EMISSION MEASUREMENT UNCERTAINTY 26
EXHIBIT 8. MEASUREMENT METHODS 27
8.1. EFFECTIVE RADIATED POWER (ERP) MEASUREMENTS 27
8.2. FREQUENCY STABILITY 29
8.3. EMISSION MASK..... 30
8.4. SPURIOUS EMISSIONS (CONDUCTED) 30
8.5. SPURIOUS EMISSIONS (RADIATED) 31
8.6. TRANSIENT FREQUENCY BEHAVIOR 33
EXHIBIT 9. MEASUREMENT DATA PLOTS 34
EXHIBIT 10. TEST SETUP PHOTOS 35
EXHIBIT 11. EXTERNAL EUT PHOTOS..... 36
EXHIBIT 12. INTERNAL EUT PHOTOS..... 37
EXHIBIT 13. COVER LETTERS..... 38
EXHIBIT 14. ATTESTATION STATEMENTS..... 39
EXHIBIT 15. APPLICATION FORMS 40
EXHIBIT 16. ID LABEL/LOCATION INFO 41
EXHIBIT 17. BLOCK DIAGRAM 42
EXHIBIT 18. SCHEMATIC DIAGRAMS..... 43

ULTRATECH GROUP OF LABS

3000 Bristol Circle, Oakville, Ontario, Canada L6H 6G4
Tel. #: 905-829-1570, Fax. #: 905-829-8050, Email: vhk.ultratech@sympatico.ca, Website: <http://www.ultratech-labs.com>

File #: MIC23-FTX
September 5, 2000

- Assessed by ITI (UK) Competent Body, NVLAP (USA) Accreditation Body & ACA/AUSTEL (Australia)
- Recognized/Listed by FCC (USA), Industry Canada (Canada)
- All test results contained in this engineering test report are traceable to National Institute of Standards and Technology (NIST)

EXHIBIT 19. PARTS LIST/TUNE UP INFO	44
EXHIBIT 20. OPERATIONAL DESCRIPTION	45
EXHIBIT 21. RF EXPOSURE INFO.....	46
EXHIBIT 22. USER'S MANUAL	47

ULTRATECH GROUP OF LABS

3000 Bristol Circle, Oakville, Ontario, Canada L6H 6G4
Tel. #: 905-829-1570, Fax. #: 905-829-8050, Email: vhk.ultratech@sympatico.ca, Website: <http://www.ultratech-labs.com>

File #: MIC23-FTX
September 5, 2000

- Assessed by ITI (UK) Competent Body, NVLAP (USA) Accreditation Body & ACA/AUSTEL (Australia)
- Recognized/Listed by FCC (USA), Industry Canada (Canada)
- *All test results contained in this engineering test report are traceable to National Institute of Standards and Technology (NIST)*

EXHIBIT 1. SUBMITTAL CHECK LIST

Exhibit No.	Exhibit Type	Description of Contents	Quality Check (OK)
1 through 8	Test Report	Exhibit 1: Submittal check lists Exhibit 2: Introduction Exhibit 3: Performance Assessment Exhibit 4: EUT Operation and Configuration during Tests Exhibit 5: Summary of test Results Exhibit 6: Measurement Data Exhibit 7: Measurement Uncertainty Exhibit 8: Measurement Methods	OK
9	Test Report - Measurement Data Plots	Occupied Bandwidth (plots # 1 to 3) Mask B (plots 4 –6) Transmitter Antenna Power Conducted Emissions (plots # 7 - 9) Transient Frequency Behavior (plots 10-11)	OK
10	Test Setup Photos	Radiated Emission at meters (photos # 1 to 2)	OK
11	External EUT Photos	External LEDR Microwave Radio Photos	OK
12	Internal EUT Photos	Internal LEDR Microwave Radio Photos	OK
13	Cover Letters	Letter from Ultratech for Certification Request Letter from the Applicant to appoint Ultratech to act as an agent Letter from the Applicant to request for Confidentiality Filing	OK
14	Attestation Statements	--	--
15	Application Forms	Form 731 Form 159	Electronic Filing
16	ID Label/Location Info	ID Label Location of ID Label	OK
17	Block Diagrams	LEDR Radio	OK
18	Schematic Diagrams	Schematic diagrams # 1 to 14	OK
19	Parts List/Tune Up Info	--	--
20	Operational Description	Theory of Operation – LEDR 400S Digital Microwave Radio	OK
21	RF Exposure Info	Refer to user's manual	OK
22	Users Manual	LEDR Subrate Series Installation and Operation Guide	OK

ULTRATECH GROUP OF LABS

3000 Bristol Circle, Oakville, Ontario, Canada L6H 6G4
Tel. #: 905-829-1570, Fax. #: 905-829-8050, Email: vhk.ultratech@sympatico.ca, Website: <http://www.ultratech-labs.com>

File #: MIC23-FTX
September 5, 2000

- Assessed by ITI (UK) Competent Body, NVLAP (USA) Accreditation Body & ACA/AUSTEL (Australia)
- Recognized/Listed by FCC (USA), Industry Canada (Canada)
- All test results contained in this engineering test report are traceable to National Institute of Standards and Technology (NIST)

EXHIBIT 2. INTRODUCTION

2.1. SCOPE

Reference:	FCC Parts 2 and 90
Title	Telecommunication - Code of Federal Regulations, CFR 47, Parts 2 & 90
Purpose of Test:	To gain FCC Certification Authorization for Radio operating in the frequency band 409 - 510 MHz (25 kHz Channel Spacing).
Test Procedures	Both conducted and radiated emissions measurements were conducted in accordance with American National Standards Institute ANSI C63.4 - American National Standard for Methods of Measurement of Radio-Noise Emissions from Low-Voltage Electrical and Electronic Equipment in the Range of 9 kHz to 40 GHz.

2.2. RELATED SUBMITAL(S)/GRANT(S)

None

2.3. NORMATIVE REFERENCES

Note: When the international publication has been modified by common modifications, indicated by (mod), the relevant EN/HD applies.

Publication	Year	Title
FCC CFR Parts 0-19, 80-End	1998	Code of Federal Regulations – Telecommunication
ANSI C63.4	1992	American National Standard for Methods of Measurement of Radio-Noise Emissions from Low-Voltage Electrical and Electronic Equipment in the Range of 9 kHz to 40 GHz
CISPR 22 & EN 55022	1997 1998	Limits and Methods of Measurements of Radio Disturbance Characteristics of Information Technology Equipment
CISPR 16-1		Specification for Radio Disturbance and Immunity measuring apparatus and methods

ULTRATECH GROUP OF LABS

3000 Bristol Circle, Oakville, Ontario, Canada L6H 6G4
Tel. #: 905-829-1570, Fax. #: 905-829-8050, Email: vhk.ultratech@sympatico.ca, Website: <http://www.ultratech-labs.com>

File #: MIC23-FTX
September 5, 2000

- Assessed by ITI (UK) Competent Body, NVLAP (USA) Accreditation Body & ACA/AUSTEL (Australia)
- Recognized/Listed by FCC (USA), Industry Canada (Canada)
- All test results contained in this engineering test report are traceable to National Institute of Standards and Technology (NIST)

EXHIBIT 3. PERFORMANCE ASSESSMENT

3.1. CLIENT INFORMATION

APPLICANT	
Name:	Microwave Data Systems Inc.
Address:	175 Science Parkway Rochester, New York USA, 14620
Contact Person:	Mr. John Cmelko Phone #: 716-242-8483 Fax #: 716-241-5590 Email Address: jcmelko@microwavedata.com

MANUFACTURER	
Name:	Microwave Data Systems Inc.
Address:	175 Science Parkway Rochester, New York USA, 14620
Contact Person:	Mr. John Cmelko Phone #: 716-242-8483 Fax #: 716-241-5590 Email Address: jcmelko@microwavedata.com

3.2. EQUIPMENT UNDER TEST (EUT) INFORMATION

The following information (with the exception of the Date of Receipt) has been supplied by the applicant.

Brand Name:	Microwave Data Systems Inc.
Product Name:	LEDR Microwave Radio
Model Name or Number:	LEDR 400S
Serial Number:	Preproduction
Type of Equipment:	Radio Communication Equipment
External Power Supply:	Auto Switch AC Power Adaptor Model DT100PW240P Input: 115/230V ~ 2A 50/60Hz DC Output: 15 VDC – 24VDC 100 W Max. Present: 24V / 4.1A Or I.T.E Power Supply Model PW100 Input: 100 – 250V ~, 50-60Hz, 2.5 – 1.3A Output: 48VDC, 1.875A
Transmitting/Receiving Antenna Type:	Non-integral
Primary User Functions of EUT:	To correctly communicate data to and from radios over RF link

ULTRATECH GROUP OF LABS

3000 Bristol Circle, Oakville, Ontario, Canada L6H 6G4
Tel. #: 905-829-1570, Fax. #: 905-829-8050, Email: vhk.ultratech@sympatico.ca, Website: <http://www.ultratech-labs.com>

File #: MIC23-FTX
September 5, 2000

- Assessed by ITI (UK) Competent Body, NVLAP (USA) Accreditation Body & ACA/AUSTEL (Australia)
- Recognized/Listed by FCC (USA), Industry Canada (Canada)
- All test results contained in this engineering test report are traceable to National Institute of Standards and Technology (NIST)

3.3. EUT'S TECHNICAL SPECIFICATIONS

TRANSMITTER	
Equipment Type:	Mobile Base station (fixed use)
Intended Operating Environment:	Commercial, light industry & heavy industry
Power Supply Requirement:	24/48 Vdc via AC Adaptor
RF Output Power Rating:	5.8 Watts Peak, 1 Watt Average
Operating Frequency Range:	409 - 510 MHz
RF Output Impedance:	50 Ohms
Channel Spacing:	25 kHz
Occupied Bandwidth (99%):	17.14 kHz (refer to measurement plots # 1 to 3 in Exhibit 9 for details)
Emission Designation:	20K0D1W
Oscillator Frequencies:	Fixed: 4.9152, MHz, 12 MHz, 20 MHz, 64MHz Variable: Tx and Rx Local Oscillators are 70 MHz above the respective Tx and Rx frequencies for high side injection.
Antenna Connector Type:	N-type

3.4. LIST OF EUT'S PORTS

Port Number	EUT's Port Description	Number of Identical Ports	Connector Type	Cable Type (Shielded/Non-shielded)
1	Console Port (RS232)	1	DB9	Shielded
2	Phone Jack	1	4 Wires	Non-shielded
3	Antenna Port	1	N Type	--
4	Ethernet NMS Port	1	RJ45	Non-shielded
5	EIA-530-A Port	1	DB25	Shielded
6	Service Channel Port	1	DB9	Shielded
7	Alarm I/O Port	1	DB9	Shielded
8	DC Power Input	1	2 Wires	Non-shielded

NOTES:

- (1) **Ports of the EUT which in normal operation** were connected to ancillary equipment through interconnecting cables via a representative interconnecting cable to simulate the input/output characteristics. RF input/output was correctly terminated to the 50 Ohm RF Load.
- (2) **Ports, which are not connected to cables during normal intended operation** (for factory/technical services uses only): None

ULTRATECH GROUP OF LABS

3000 Bristol Circle, Oakville, Ontario, Canada L6H 6G4
Tel. #: 905-829-1570, Fax. #: 905-829-8050, Email: vhk.ultratech@sympatico.ca, Website: <http://www.ultratech-labs.com>

File #: MIC23-FTX
September 5, 2000

- Assessed by ITI (UK) Competent Body, NVLAP (USA) Accreditation Body & ACA/AUSTEL (Australia)
- Recognized/Listed by FCC (USA), Industry Canada (Canada)
- All test results contained in this engineering test report are traceable to National Institute of Standards and Technology (NIST)

EXHIBIT 4. EUT OPERATING CONDITIONS AND CONFIGURATIONS DURING TESTS

4.1. CLIMATE TEST CONDITIONS

The climate conditions of the test environment are as follows:

Temperature:	21°C
Humidity:	51%
Pressure:	101 kPa
Power input source:	24/48 Vdc via AC Adaptor

4.2. OPERATIONAL TEST CONDITIONS & ARRANGEMENT FOR TEST SIGNALS

Operating Modes:	The transmitter was operated in a continuous transmission mode with the carrier modulated as specified in the Test Data.
Special Test Software:	N/A
Special Hardware Used:	N/A
Transmitter Test Antenna:	The EUT is tested with the transmitter antenna port terminated to a 50 Ohms Load.

Transmitter Test Signals	
Frequencies:	Near lowest, near middle & near highest frequencies each frequency bands that the transmitter covers:
<ul style="list-style-type: none"> ▪ 409 - 510 MHz band: 	<ul style="list-style-type: none"> ▪ 409 MHz (lowest frequency) ▪ 450.9 MHz (middle frequency) ▪ 510 MHz (highest frequency)
Transmitter Wanted Output Test Signals:	
<ul style="list-style-type: none"> ▪ RF Power Output (measured maximum output power): ▪ Normal Test Modulation ▪ Modulating signal source: 	<ul style="list-style-type: none"> ▪ 5.8 Watts Peak, 1 Watt Average ▪ 32-QAM data modulation at 64 kbps ▪ Internal

ULTRATECH GROUP OF LABS

3000 Bristol Circle, Oakville, Ontario, Canada L6H 6G4
Tel. #: 905-829-1570, Fax. #: 905-829-8050, Email: vhk.ultratech@sympatico.ca, Website: <http://www.ultratech-labs.com>

File #: MIC23-FTX
September 5, 2000

- Assessed by ITI (UK) Competent Body, NVLAP (USA) Accreditation Body & ACA/AUSTEL (Australia)
- Recognized/Listed by FCC (USA), Industry Canada (Canada)
- All test results contained in this engineering test report are traceable to National Institute of Standards and Technology (NIST)

EXHIBIT 5. SUMMARY OF TEST RESULTS

5.1. LOCATION OF TESTS

All of the measurements described in this report were performed at Ultratech Group of Labs located in the city of Oakville, Province of Ontario, Canada.

- AC Powerline Conducted Emissions were performed in UltraTech's shielded room, 16'(L) by 12'(W) by 12'(H).
- Radiated Emissions were performed at the Ultratech's 3 Meter Open Field Test Site (OFTS) situated in the Town of Oakville, province of Ontario.

The above sites have been calibrated in accordance with ANSI C63.4, and found to be in compliance with the requirements of Sec. 2.948 of the FCC Rules. The descriptions and site measurement data of the Oakville Open Field Test Site has been filed with FCC office (FCC File No.: 31040/SIT 1300B3) and Industry Canada office (Industry Canada File No.: IC2049). Last Date of Site Calibration: Sep. 20, 1999.

5.2. APPLICABILITY & SUMMARY OF EMC EMISSION TEST RESULTS

FCC PARAGRAPH.	TEST REQUIREMENTS	APPLICABILITY (YES/NO)
90.205 & 2.985	RF Power Output	Yes
90.213 & 2.995	Frequency Stability	Yes
90.209 90.210 & 2.989	Emission Limitation & Emission Mask	Yes
90.210, 2.997 & 2.991	Emission Limits - Spurious Emissions at Antenna Terminal	Yes
90.210, 2.997 & 2.993	Emission Limits - Field Strength of Spurious Emissions	Yes
90.214	Transient Frequency Behavior	Yes

LEDR Microwave Radio, Model No.: LEDR 400S, by **Microwave Data Systems Inc.** has also been tested and found to comply with **FCC Part 15, Subpart B - Radio Receivers and Class A Digital Devices**. The engineering test report has been documented and kept in file and it is available anytime upon FCC request.

5.3. MODIFICATIONS INCORPORATED IN THE EUT FOR COMPLIANCE PURPOSES

None

ULTRATECH GROUP OF LABS

3000 Bristol Circle, Oakville, Ontario, Canada L6H 6G4
Tel. #: 905-829-1570, Fax. #: 905-829-8050, Email: vhk.ultratech@sympatico.ca, Website: <http://www.ultratech-labs.com>

File #: MIC23-FTX
September 5, 2000

- Assessed by ITI (UK) Competent Body, NVLAP (USA) Accreditation Body & ACA/AUSTEL (Australia)
- Recognized/Listed by FCC (USA), Industry Canada (Canada)
- All test results contained in this engineering test report are traceable to National Institute of Standards and Technology (NIST)

EXHIBIT 6. MEASUREMENTS, EXAMINATIONS & TEST DATA FOR EMC EMISSIONS

6.1. TEST PROCEDURES

This section contains test results only. Details of test methods and procedures can be found in Exhibit 8 of this report

6.2. MEASUREMENT UNCERTAINTIES

The measurement uncertainties stated were calculated in accordance with requirements of UKAS Document NIS 81 with a confidence level of 95%. Please refer to Exhibit 7 for Measurement Uncertainties.

6.3. MEASUREMENT EQUIPMENT USED:

The measurement equipment used complied with the requirements of the Standards referenced in the Methods & Procedures ANSI C63.4:1992 and CISPR 16-1.

6.4. ESSENTIAL/PRIMARY FUNCTIONS AS DECLARED BY THE MANUFACTURER:

The essential function of the EUT is to correctly communicate data to and from radios over RF link.

ULTRATECH GROUP OF LABS

3000 Bristol Circle, Oakville, Ontario, Canada L6H 6G4
Tel. #: 905-829-1570, Fax. #: 905-829-8050, Email: vhk.ultratech@sympatico.ca, Website: <http://www.ultratech-labs.com>

File #: MIC23-FTX
September 5, 2000

- Assessed by ITI (UK) Competent Body, NVLAP (USA) Accreditation Body & ACA/AUSTEL (Australia)
- Recognized/Listed by FCC (USA), Industry Canada (Canada)
- *All test results contained in this engineering test report are traceable to National Institute of Standards and Technology (NIST)*

6.5. RF POWER OUTPUT @ FCC 2.985 & 90.205

6.5.1. Limits @ FCC 90.205

Please refer to FCC CFR 47, Part 90, Subpart I, Para. 90.205 for specification details.

6.5.2. Method of Measurements

Please refer to Exhibit 8, Sec. 8.1 for test procedures and test setup.

- The transmitter terminal was coupled to the Spectrum Analyzer through a 20 dB attenuator
- Power of the transmitter channel near the lowest, middle and highest of each frequency block/band were measured using the power meter, and the reading was corrected by added the calibrated attenuator's attenuation value and cable loss.
- The RF Output was turned on with standard modulation applied.

6.5.3. Test Equipment List

Test Instruments	Manufacturer	Model No.	Serial No.	Frequency Range
Spectrum Analyzer/ EMI Receiver	Hewlett Packard	HP 8593EM	3412A00103	9 kHz – 26.5 GHz
Attenuator(s)	Bird	DC – 22 GHz

6.5.4. Test Arrangement

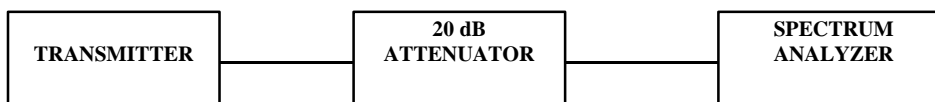

6.5.5. Test Data

TRANSMITTER CHANNEL OUTPUT	FUNDAMENTAL FREQUENCY (MHz)	MEASURED AVERAGE POWER (P) (dBm)	AVERAGE POWER RATING (dBm)
Lowest	409	30	30
Middle	450.9	30	30
Highest	510	30	30

Note: The EUT was tested with two different power levels, using 24 Vdc and 48 Vdc power supply. The measured average power values for both powers are the same, since the EUT contained a 12 Vdc power regulator.

EIRP Measurements: Appropriated antenna type and adjustment of power output for effective radiated power (ERP) to meet FCC limits will be performed by the manufacturer at location of installation.

ULTRATECH GROUP OF LABS

3000 Bristol Circle, Oakville, Ontario, Canada L6H 6G4
Tel. #: 905-829-1570, Fax. #: 905-829-8050, Email: vhk.ultratech@sympatico.ca, Website: <http://www.ultratech-labs.com>

File #: MIC23-FTX
September 5, 2000

- Assessed by ITI (UK) Competent Body, NVLAP (USA) Accreditation Body & ACA/AUSTEL (Australia)
- Recognized/Listed by FCC (USA), Industry Canada (Canada)
- All test results contained in this engineering test report are traceable to National Institute of Standards and Technology (NIST)

6.6. FREQUENCY STABILITY @ FCC 2.995 & 90.213

6.6.1. Limits @ FCC 90.213

Please refer to FCC CFR 47, Part 90, Subpart I, Para. 90.213 for specification details.

FREQUENCY RANGE (MHz)	FIXED & BASE STATIONS			MOBILE STATIONS					
	(ppm)			(ppm)					
				> 2 W			≤ 2 W		
	6.25 kHz	12.5 kHz	25 kHz	6.25 kHz	12.5 kHz	25 kHz	6.25 kHz	12.5 kHz	25 kHz
403-512 MHz	0.5	1.5	2.5	1.0	2.5	5.0	1.0	2.5	5.0

6.6.2. Method of Measurements

Refer to FCC @ 2.995

- (a) The frequency stability shall be measured with variation of ambient temperature as follows: From -30 to +50 centigrade except that specified in subparagraph (2) & (3) of this paragraph.
- (b) Frequency measurements shall be made at extremes of the specified temperature range and at intervals of not more than 10 centigrade through the range. A period of time sufficient to stabilize all of the components of the oscillator circuit at each temperature level shall be allowed prior to frequency measurement. The short term transient effects on the frequency of the transmitter due to keying (except for broadcast transmitters) and any heating element cycling normally occurring at each ambient temperature level also shall be shown. Only the portion or portions of the transmitter containing the frequency determining and stability circuitry need be subjected to the temperature variation test.
- (d) The frequency stability supply shall be measured with variation of primary supply voltage as follows:
 - (1) Vary primary supply voltage from 85 to 115 percent of the nominal value for other than hand carried battery equipment.
 - (2) For hand carried, battery powered equipment, reduce primary supply voltage to the battery operating end point which shall be specified by the manufacturer.
 - (3) The supply voltage shall be measured at the input to the cable normally provide with the equipment, or at the power supply terminals if cables are not normally provided. Effects on frequency of transmitter keying (except for broadcast transmitters) and any heating element cycling at the nominal supply voltage and at each extreme also shall be shown.
- (e) When deemed necessary, the Commission may require tests of frequency stability under conditions in addition to those specifically set out in paragraphs (a), (b), (c) and (d) of this section. (For example, measurements showing the effect of proximity to large metal objects, or of various types of antennas, may be required for portable equipment).

ULTRATECH GROUP OF LABS

3000 Bristol Circle, Oakville, Ontario, Canada L6H 6G4
Tel. #: 905-829-1570, Fax. #: 905-829-8050, Email: vhk.ultratech@sympatico.ca, Website: <http://www.ultratech-labs.com>

File #: MIC23-FTX
September 5, 2000

- Assessed by ITI (UK) Competent Body, NVLAP (USA) Accreditation Body & ACA/AUSTEL (Australia)
- Recognized/Listed by FCC (USA), Industry Canada (Canada)
- All test results contained in this engineering test report are traceable to National Institute of Standards and Technology (NIST)

6.6.3. Test Equipment List

Test Instruments	Manufacturer	Model No.	Serial No.	Frequency Range
Spectrum Analyzer/ EMI Receiver	Hewlett Packard	HP 8593EM	3412A00103	9 kHz – 26.5 GHz
Attenuator(s)	Bird	DC – 22 GHz
Temperature & Humidity Chamber	Tenney	T5	9723B	-40° to +60° C range

6.6.4. Test Arrangement

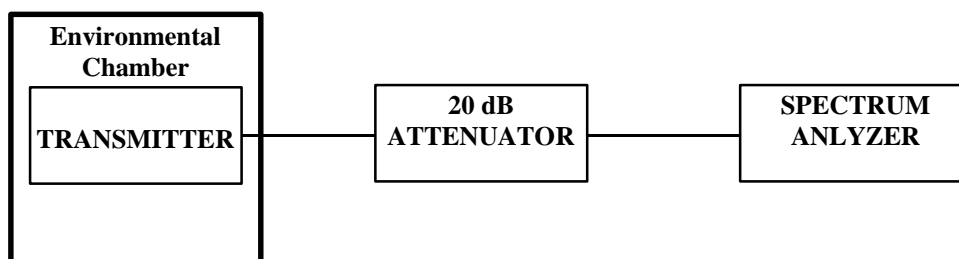

6.6.5. Test Data

Product Name	LEDR Microwave Radio
Model No.	LEDR 400S
Center Frequency	409 MHz
Full Power Level	5.8 Watts Peak, 1 Watt Average
Frequency Tolerance Limit	2.5 ppm or 1022.5 Hz
Max. Frequency Tolerance Measured	390 Hz or 0.95 ppm
Input Voltage Rating	24 Vdc

ULTRATECH GROUP OF LABS

3000 Bristol Circle, Oakville, Ontario, Canada L6H 6G4
Tel. #: 905-829-1570, Fax. #: 905-829-8050, Email: vhk.ultratech@sympatico.ca, Website: <http://www.ultratech-labs.com>

File #: MIC23-FTX
September 5, 2000

- Assessed by ITI (UK) Competent Body, NVLAP (USA) Accreditation Body & ACA/AUSTEL (Australia)
- Recognized/Listed by FCC (USA), Industry Canada (Canada)
- All test results contained in this engineering test report are traceable to National Institute of Standards and Technology (NIST)

AMBIENT TEMP. (°C)	KEYED-ON TIME (Minutes)	CENTER FREQUENCY & RF POWER OUTPUT VARIATION					
		Supply Voltage (Nominal) 24 Volts		Supply Voltage (85% of Nominal) 20.4 Volts		Supply Voltage (115% of Nominal) 27.6 Volts	
		Hz	dB	Hz	dB	Hz	dB
-30	0	0	N/A	N/A	N/A	N/A	N/A
	1	10	N/A	N/A	N/A	N/A	N/A
	2	0	N/A	N/A	N/A	N/A	N/A
	3	10	N/A	N/A	N/A	N/A	N/A
	4	10	N/A	N/A	N/A	N/A	N/A
	5	10	N/A	N/A	N/A	N/A	N/A
	6	0	N/A	N/A	N/A	N/A	N/A
	7	10	N/A	N/A	N/A	N/A	N/A
	8	0	N/A	N/A	N/A	N/A	N/A
	9	10	N/A	N/A	N/A	N/A	N/A
	10	0	N/A	N/A	N/A	N/A	N/A
-20	0	-60	N/A	N/A	N/A	N/A	N/A
	1	-40	N/A	N/A	N/A	N/A	N/A
	2	-60	N/A	N/A	N/A	N/A	N/A
	3	-60	N/A	N/A	N/A	N/A	N/A
	4	-40	N/A	N/A	N/A	N/A	N/A
	5	-60	N/A	N/A	N/A	N/A	N/A
	6	-60	N/A	N/A	N/A	N/A	N/A
	7	-60	N/A	N/A	N/A	N/A	N/A
	8	-60	N/A	N/A	N/A	N/A	N/A
	9	-60	N/A	N/A	N/A	N/A	N/A
	10	-60	N/A	N/A	N/A	N/A	N/A
-10	0	70	N/A	N/A	N/A	N/A	N/A
	1	60	N/A	N/A	N/A	N/A	N/A
	2	60	N/A	N/A	N/A	N/A	N/A
	3	60	N/A	N/A	N/A	N/A	N/A
	4	60	N/A	N/A	N/A	N/A	N/A
	5	60	N/A	N/A	N/A	N/A	N/A
	6	60	N/A	N/A	N/A	N/A	N/A
	7	60	N/A	N/A	N/A	N/A	N/A
	8	60	N/A	N/A	N/A	N/A	N/A
	9	60	N/A	N/A	N/A	N/A	N/A
	10	60	N/A	N/A	N/A	N/A	N/A

ULTRATECH GROUP OF LABS

3000 Bristol Circle, Oakville, Ontario, Canada L6H 6G4
Tel. #: 905-829-1570, Fax. #: 905-829-8050, Email: vhk.ultratech@sympatico.ca, Website: <http://www.ultratech-labs.com>

File #: MIC23-FTX
September 5, 2000

- Assessed by ITI (UK) Competent Body, NVLAP (USA) Accreditation Body & ACA/AUSTEL (Australia)
- Recognized/Listed by FCC (USA), Industry Canada (Canada)
- All test results contained in this engineering test report are traceable to National Institute of Standards and Technology (NIST)

AMBIENT TEMP. (°C)	KEYED-ON TIME (Minutes)	CENTER FREQUENCY & RF POWER OUTPUT VARIATION					
		Supply Voltage (Nominal) 24 Volts		Supply Voltage (85% of Nominal) 20.4 Volts		Supply Voltage (115% of Nominal) 27.6 Volts	
		Hz	dB	Hz	dB	Hz	dB
0	0	140	N/A	N/A	N/A	N/A	N/A
	1	160	N/A	N/A	N/A	N/A	N/A
	2	140	N/A	N/A	N/A	N/A	N/A
	3	140	N/A	N/A	N/A	N/A	N/A
	4	140	N/A	N/A	N/A	N/A	N/A
	5	140	N/A	N/A	N/A	N/A	N/A
	6	140	N/A	N/A	N/A	N/A	N/A
	7	140	N/A	N/A	N/A	N/A	N/A
	8	140	N/A	N/A	N/A	N/A	N/A
	9	140	N/A	N/A	N/A	N/A	N/A
	10	140	N/A	N/A	N/A	N/A	N/A
+10	0	70	N/A	N/A	N/A	N/A	N/A
	1	70	N/A	N/A	N/A	N/A	N/A
	2	70	N/A	N/A	N/A	N/A	N/A
	3	70	N/A	N/A	N/A	N/A	N/A
	4	70	N/A	N/A	N/A	N/A	N/A
	5	70	N/A	N/A	N/A	N/A	N/A
	6	70	N/A	N/A	N/A	N/A	N/A
	7	70	N/A	N/A	N/A	N/A	N/A
	8	70	N/A	N/A	N/A	N/A	N/A
	9	70	N/A	N/A	N/A	N/A	N/A
	10	70	N/A	N/A	N/A	N/A	N/A
+20	0	-30	0.2	10	0.2	30	0.4
	1	-10	0.2	10	0.3	10	0.4
	2	-30	0.3	30	0.8	30	1.0
	3	-10	0.2	10	0.1	30	1.0
	4	-30	0.2	10	0.5	10	0.4
	5	-10	0.2	10	0.4	10	0.5
	6	-10	0.2	10	0.5	10	0.4
	7	-30	0.2	10	0.2	30	0.7
	8	-30	0.2	10	0.5	30	0.9
	9	-10	0.2	30	0.7	30	1.5
	10	-10	0.2	10	0.2	30	0.7

ULTRATECH GROUP OF LABS

3000 Bristol Circle, Oakville, Ontario, Canada L6H 6G4
Tel. #: 905-829-1570, Fax. #: 905-829-8050, Email: vhk.ultratech@sympatico.ca, Website: <http://www.ultratech-labs.com>

File #: MIC23-FTX
September 5, 2000

- Assessed by ITI (UK) Competent Body, NVLAP (USA) Accreditation Body & ACA/AUSTEL (Australia)
- Recognized/Listed by FCC (USA), Industry Canada (Canada)
- All test results contained in this engineering test report are traceable to National Institute of Standards and Technology (NIST)

AMBIENT TEMP. (°C)	KEYED-ON TIME (Minutes)	CENTER FREQUENCY & RF POWER OUTPUT VARIATION					
		Supply Voltage (Nominal) 24 Volts		Supply Voltage (85% of Nominal) 20.4 Volts		Supply Voltage (115% of Nominal) 27.6 Volts	
		Hz	dB	Hz	dB	Hz	dB
+30	0	-60	N/A	N/A	N/A	N/A	N/A
	1	-40	N/A	N/A	N/A	N/A	N/A
	2	-60	N/A	N/A	N/A	N/A	N/A
	3	-60	N/A	N/A	N/A	N/A	N/A
	4	-60	N/A	N/A	N/A	N/A	N/A
	5	-60	N/A	N/A	N/A	N/A	N/A
	6	-60	N/A	N/A	N/A	N/A	N/A
	7	-40	N/A	N/A	N/A	N/A	N/A
	8	-40	N/A	N/A	N/A	N/A	N/A
	9	-60	N/A	N/A	N/A	N/A	N/A
+40	0	-70	N/A	N/A	N/A	N/A	N/A
	1	-70	N/A	N/A	N/A	N/A	N/A
	2	-70	N/A	N/A	N/A	N/A	N/A
	3	-60	N/A	N/A	N/A	N/A	N/A
	4	-90	N/A	N/A	N/A	N/A	N/A
	5	-60	N/A	N/A	N/A	N/A	N/A
	6	-60	N/A	N/A	N/A	N/A	N/A
	7	-70	N/A	N/A	N/A	N/A	N/A
	8	-70	N/A	N/A	N/A	N/A	N/A
	9	-70	N/A	N/A	N/A	N/A	N/A
+50	0	390	N/A	N/A	N/A	N/A	N/A
	1	390	N/A	N/A	N/A	N/A	N/A
	2	390	N/A	N/A	N/A	N/A	N/A
	3	390	N/A	N/A	N/A	N/A	N/A
	4	390	N/A	N/A	N/A	N/A	N/A
	5	390	N/A	N/A	N/A	N/A	N/A
	6	390	N/A	N/A	N/A	N/A	N/A
	7	390	N/A	N/A	N/A	N/A	N/A
	8	390	N/A	N/A	N/A	N/A	N/A
	9	390	N/A	N/A	N/A	N/A	N/A
10	390	N/A	N/A	N/A	N/A	N/A	

ULTRATECH GROUP OF LABS

3000 Bristol Circle, Oakville, Ontario, Canada L6H 6G4
Tel. #: 905-829-1570, Fax. #: 905-829-8050, Email: vhk.ultratech@sympatico.ca, Website: <http://www.ultratech-labs.com>

File #: MIC23-FTX
September 5, 2000

- Assessed by ITI (UK) Competent Body, NVLAP (USA) Accreditation Body & ACA/AUSTEL (Australia)
- Recognized/Listed by FCC (USA), Industry Canada (Canada)
- All test results contained in this engineering test report are traceable to National Institute of Standards and Technology (NIST)

Product Name	LEDR Microwave Radio
Model No.	LEDR 400S
Center Frequency	409 MHz
Full Power Level	5.8 Watts Peak, 1 Watt Average
Frequency Tolerance Limit	2.5 ppm or 1022.5 Hz
Max. Frequency Tolerance Measured	430 Hz or 1.05ppm
Input Voltage Rating	48 Vdc

		CENTER FREQUENCY & RF POWER OUTPUT VARIATION					
AMBIENT TEMP. (°C)	KEYED-ON TIME (Minutes)	Supply Voltage (Nominal) 48 Volts		Supply Voltage (85% of Nominal) 40.8 Volts		Supply Voltage (115% of Nominal) 55.2 Volts	
		Hz	dB	Hz	dB	Hz	dB
		-30	0	200	N/A	N/A	N/A
1	190		N/A	N/A	N/A	N/A	N/A
2	200		N/A	N/A	N/A	N/A	N/A
3	190		N/A	N/A	N/A	N/A	N/A
4	200		N/A	N/A	N/A	N/A	N/A
5	200		N/A	N/A	N/A	N/A	N/A
6	200		N/A	N/A	N/A	N/A	N/A
7	190		N/A	N/A	N/A	N/A	N/A
8	200		N/A	N/A	N/A	N/A	N/A
9	190		N/A	N/A	N/A	N/A	N/A
10	200	N/A	N/A	N/A	N/A	N/A	N/A
-20	0	270	N/A	N/A	N/A	N/A	N/A
	1	270	N/A	N/A	N/A	N/A	N/A
	2	270	N/A	N/A	N/A	N/A	N/A
	3	270	N/A	N/A	N/A	N/A	N/A
	4	270	N/A	N/A	N/A	N/A	N/A
	5	270	N/A	N/A	N/A	N/A	N/A
	6	270	N/A	N/A	N/A	N/A	N/A
	7	270	N/A	N/A	N/A	N/A	N/A
	8	270	N/A	N/A	N/A	N/A	N/A
	9	270	N/A	N/A	N/A	N/A	N/A
10	270	N/A	N/A	N/A	N/A	N/A	N/A
-10	0	430	N/A	N/A	N/A	N/A	N/A
	1	410	N/A	N/A	N/A	N/A	N/A
	2	430	N/A	N/A	N/A	N/A	N/A
	3	410	N/A	N/A	N/A	N/A	N/A
	4	430	N/A	N/A	N/A	N/A	N/A
	5	410	N/A	N/A	N/A	N/A	N/A
	6	430	N/A	N/A	N/A	N/A	N/A
	7	410	N/A	N/A	N/A	N/A	N/A
	8	430	N/A	N/A	N/A	N/A	N/A
	9	410	N/A	N/A	N/A	N/A	N/A
10	430	N/A	N/A	N/A	N/A	N/A	N/A

ULTRATECH GROUP OF LABS

3000 Bristol Circle, Oakville, Ontario, Canada L6H 6G4
Tel. #: 905-829-1570, Fax. #: 905-829-8050, Email: vhk.ultratech@sympatico.ca, Website: <http://www.ultratech-labs.com>

File #: MIC23-FTX
September 5, 2000

- Assessed by ITI (UK) Competent Body, NVLAP (USA) Accreditation Body & ACA/AUSTEL (Australia)
- Recognized/Listed by FCC (USA), Industry Canada (Canada)
- All test results contained in this engineering test report are traceable to National Institute of Standards and Technology (NIST)

		CENTER FREQUENCY & RF POWER OUTPUT VARIATION					
AMBIENT TEMP. (°C)	KEYED-ON TIME (Minutes)	Supply Voltage (Nominal) 48 Volts		Supply Voltage (85% of Nominal) 40.8 Volts		Supply Voltage (115% of Nominal) 55.2 Volts	
		Hz	dB	Hz	dB	Hz	dB
0	0	400	N/A	N/A	N/A	N/A	N/A
	1	410	N/A	N/A	N/A	N/A	N/A
	2	400	N/A	N/A	N/A	N/A	N/A
	3	400	N/A	N/A	N/A	N/A	N/A
	4	400	N/A	N/A	N/A	N/A	N/A
	5	410	N/A	N/A	N/A	N/A	N/A
	6	400	N/A	N/A	N/A	N/A	N/A
	7	400	N/A	N/A	N/A	N/A	N/A
	8	410	N/A	N/A	N/A	N/A	N/A
	9	400	N/A	N/A	N/A	N/A	N/A
+10	0	270	N/A	N/A	N/A	N/A	N/A
	1	270	N/A	N/A	N/A	N/A	N/A
	2	290	N/A	N/A	N/A	N/A	N/A
	3	270	N/A	N/A	N/A	N/A	N/A
	4	290	N/A	N/A	N/A	N/A	N/A
	5	290	N/A	N/A	N/A	N/A	N/A
	6	270	N/A	N/A	N/A	N/A	N/A
	7	290	N/A	N/A	N/A	N/A	N/A
	8	290	N/A	N/A	N/A	N/A	N/A
	9	290	N/A	N/A	N/A	N/A	N/A
+20	0	0	0	10	0.1	40	2.1
	1	-10	0.1	0	0	10	0.4
	2	0	0	10	0.5	30	1.3
	3	-10	0.2	10	0.2	30	1.6
	4	0	0	10	0.2	40	2.3
	5	0	0	10	0.4	30	1.5
	6	-10	0.1	30	0.6	40	1.9
	7	0	0	30	1.3	40	2.7
	8	0	0	10	0.6	40	2.2
	9	10	0.2	30	0.8	30	1.6
+30	0	-110	N/A	N/A	N/A	N/A	N/A
	1	-130	N/A	N/A	N/A	N/A	N/A
	2	-130	N/A	N/A	N/A	N/A	N/A
	3	-110	N/A	N/A	N/A	N/A	N/A
	4	-130	N/A	N/A	N/A	N/A	N/A
	5	-130	N/A	N/A	N/A	N/A	N/A
	6	-110	N/A	N/A	N/A	N/A	N/A
	7	-130	N/A	N/A	N/A	N/A	N/A
	8	-110	N/A	N/A	N/A	N/A	N/A
	9	-130	N/A	N/A	N/A	N/A	N/A
10	-110	N/A	N/A	N/A	N/A	N/A	

ULTRATECH GROUP OF LABS

3000 Bristol Circle, Oakville, Ontario, Canada L6H 6G4
Tel. #: 905-829-1570, Fax. #: 905-829-8050, Email: vhk.ultratech@sympatico.ca, Website: <http://www.ultratech-labs.com>

File #: MIC23-FTX
September 5, 2000

- Assessed by ITI (UK) Competent Body, NVLAP (USA) Accreditation Body & ACA/AUSTEL (Australia)
- Recognized/Listed by FCC (USA), Industry Canada (Canada)
- All test results contained in this engineering test report are traceable to National Institute of Standards and Technology (NIST)

		CENTER FREQUENCY & RF POWER OUTPUT VARIATION					
AMBIENT TEMP. (°C)	KEYED-ON TIME (Minutes)	Supply Voltage (Nominal) 48 Volts		Supply Voltage (85% of Nominal) 40.8 Volts		Supply Voltage (115% of Nominal) 55.2 Volts	
		Hz	dB	Hz	dB	Hz	dB
+40	0	-310	N/A	N/A	N/A	N/A	N/A
	1	-310	N/A	N/A	N/A	N/A	N/A
	2	-310	N/A	N/A	N/A	N/A	N/A
	3	-310	N/A	N/A	N/A	N/A	N/A
	4	-310	N/A	N/A	N/A	N/A	N/A
	5	-310	N/A	N/A	N/A	N/A	N/A
	6	-310	N/A	N/A	N/A	N/A	N/A
	7	-310	N/A	N/A	N/A	N/A	N/A
	8	-310	N/A	N/A	N/A	N/A	N/A
	9	-310	N/A	N/A	N/A	N/A	N/A
	10	-310	N/A	N/A	N/A	N/A	N/A
+50	0	-100	N/A	N/A	N/A	N/A	N/A
	1	-130	N/A	N/A	N/A	N/A	N/A
	2	-100	N/A	N/A	N/A	N/A	N/A
	3	-130	N/A	N/A	N/A	N/A	N/A
	4	-100	N/A	N/A	N/A	N/A	N/A
	5	-110	N/A	N/A	N/A	N/A	N/A
	6	-100	N/A	N/A	N/A	N/A	N/A
	7	-110	N/A	N/A	N/A	N/A	N/A
	8	-110	N/A	N/A	N/A	N/A	N/A
	9	-110	N/A	N/A	N/A	N/A	N/A
	10	-110	N/A	N/A	N/A	N/A	N/A

ULTRATECH GROUP OF LABS

3000 Bristol Circle, Oakville, Ontario, Canada L6H 6G4
Tel. #: 905-829-1570, Fax. #: 905-829-8050, Email: vhk.ultratech@sympatico.ca, Website: <http://www.ultratech-labs.com>

File #: MIC23-FTX
September 5, 2000

- Assessed by ITI (UK) Competent Body, NVLAP (USA) Accreditation Body & ACA/AUSTEL (Australia)
- Recognized/Listed by FCC (USA), Industry Canada (Canada)
- All test results contained in this engineering test report are traceable to National Institute of Standards and Technology (NIST)

6.7. EMISSION MASK @ FCC 2.989, 90.208 & 90.210

6.7.1. Limits @ FCC 90.209 & 90.210

Emissions shall be attenuated below the mean output power of the transmitter as follows:

Frequency Range (MHz)	Maximum Authorized BW (KHz)	Channel Spacing (KHz)	Recommended Frequency Deviation (KHz)	FCC Applicable Mask
403-512	20.0	25.0	5.0	<ul style="list-style-type: none"> 90.210(b): Mask B – Voice 90.210(c): Mask C – Data

6.7.2. Method of Measurements

Refer to Exhibit 8, Sec. 8.3 of this report for measurement details

6.7.3. Test Equipment List

Test Instruments	Manufacturer	Model No.	Serial No.	Frequency Range
Spectrum Analyzer/ EMI Receiver	Hewlett Packard	HP 8593EM	3412A00103	9 kHz – 26.5 GHz
Attenuator(s)	Bird	DC – 22 GHz
Audio Oscillator	Hewlett Packard	HP 204C	0989A08798	DC to 1.2 MHz

6.7.4. Test Arrangement

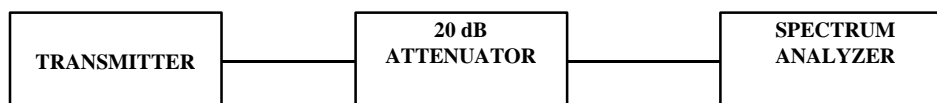

6.7.5. Test Data

Conform. Please refer to EXHIBIT 9 plots # 4 to 6 for details of measurements.

ULTRATECH GROUP OF LABS

3000 Bristol Circle, Oakville, Ontario, Canada L6H 6G4
Tel. #: 905-829-1570, Fax. #: 905-829-8050, Email: vhk.ultratech@sympatico.ca, Website: <http://www.ultratech-labs.com>

File #: MIC23-FTX
September 5, 2000

- Assessed by ITI (UK) Competent Body, NVLAP (USA) Accreditation Body & ACA/AUSTEL (Australia)
- Recognized/Listed by FCC (USA), Industry Canada (Canada)
- All test results contained in this engineering test report are traceable to National Institute of Standards and Technology (NIST)

6.8. TRANSMITTER ANTENNA POWER SPURIOUS/HARMONIC CONDUCTED EMISSIONS @ FCC 90.210

6.8.1. Limits @ 90.210

Emissions shall be attenuated below the mean output power of the transmitter as follows:

FCC RULES	FREQUENCY RANGE	ATTENUATION LIMIT (dBc)
90.210(b)&(c) – Voice & data	10 MHz to Lowest frequency of the radio to 10 th harmonic of the highest frequency of the radio	43+10*log(P) or -13 dBm
90.210(d) – Voice & data	10 MHz to Lowest frequency of the radio to 10 th harmonic of the highest frequency of the radio	50+10*log(P) or -20 dBm or 70 dBc whichever is less
90.210(e) – Voice & data	10 MHz to Lowest frequency of the radio to 10 th harmonic of the highest frequency of the radio	55+10*log(P) or -25 dBm or 65 dBc whichever is less

6.8.2. Method of Measurements

Refer to Exhibit 8, Sec. 8.4 of this report for measurement details

6.8.3. Test Equipment List

Test Instruments	Manufacturer	Model No.	Serial No.	Frequency Range
Spectrum Analyzer/ EMI Receiver	Hewlett Packard	HP 8593EM	3412A00103	9 kHz – 26.5 GHz
Attenuator(s)	Bird	DC – 22 GHz
Audio Oscillator	Hewlett Packard	HP 204C	0989A08798	DC to 1.2 MHz
Hihpass Filter, Microphase	Microphase	CR220HID	IITI11000AC	Cut-off Frequency at 600 MHz, 1.3 GHz or 4 GHz

6.8.4. Test Arrangement

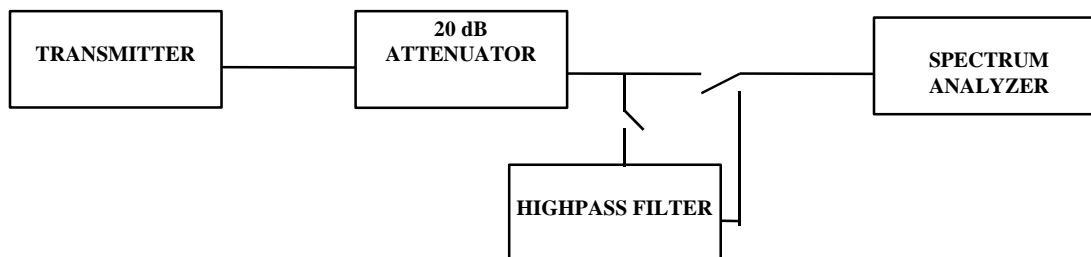

ULTRATECH GROUP OF LABS

3000 Bristol Circle, Oakville, Ontario, Canada L6H 6G4
Tel. #: 905-829-1570, Fax. #: 905-829-8050, Email: vhk.ultratech@sympatico.ca, Website: <http://www.ultratech-labs.com>

File #: MIC23-FTX
September 5, 2000

- Assessed by ITI (UK) Competent Body, NVLAP (USA) Accreditation Body & ACA/AUSTEL (Australia)
- Recognized/Listed by FCC (USA), Industry Canada (Canada)
- All test results contained in this engineering test report are traceable to National Institute of Standards and Technology (NIST)

6.8.5. Test Data

Please refer to Plots # 7 to 9 in Exhibit 9 for details of measurements

Remarks:

- The Radiated emissions were performed at 3 meters distance.

6.8.5.1. Near Lowest Frequency (409 MHz)

Fundamental Frequency: 409 MHz					
RF Output Power: 5.8 Watts Peak, 1 Watt Average					
Modulation: 32-QAM modulation with random data @ 64 kbps (with audio filter)					
Frequency (MHz)	RF Level (dBm)	Detector Used (Peak/QP)	Limit (dBm)	Margin (dB)	Conclusion (PASS/FAIL)
209.4	-23.66	Peak	-13	-10.66	PASS
The emissions were scanned from 10 MHz to 5 GHz and all emissions less 20 dB below the limits were recorded.					

6.8.5.2. Near Middle Frequency (450.9 MHz)

Fundamental Frequency: 450.9 MHz					
RF Output Power: 4.4 Watts Peak, 1 Watt Average					
Modulation: 32-QAM modulation with random data @ 64 kbps (with audio filter)					
Frequency (MHz)	RF Level (dBm)	Detector Used (Peak/QP)	Limit (dBm)	Margin (dB)	Conclusion (PASS/FAIL)
31.2	-20.94	Peak	-13	-7.94	PASS
209.4	-26.69	Peak	-13	-13.69	PASS
The emissions were scanned from 10 MHz to 5 GHz and all emissions less 20 dB below the limits were recorded.					

6.8.5.3. Near Highest Frequency (510 MHz)

Fundamental Frequency: 510 MHz					
RF Output Power: 5.8 Watts Peak, 1 Watt Average					
Modulation: 32-QAM modulation with random data @ 64 kbps (with audio filter)					
Frequency (MHz)	RF Level (dBm)	Detector Used (Peak/QP)	Limit (dBm)	Margin (dB)	Conclusion (PASS/FAIL)
209.4	-26.88	Peak	-13	-13.88	PASS
The emissions were scanned from 10 MHz to 5 GHz and all emissions less 20 dB below the limits were recorded.					

ULTRATECH GROUP OF LABS

3000 Bristol Circle, Oakville, Ontario, Canada L6H 6G4
Tel. #: 905-829-1570, Fax. #: 905-829-8050, Email: vhk.ultratech@sympatico.ca, Website: <http://www.ultratech-labs.com>

File #: MIC23-FTX
September 5, 2000

- Assessed by ITI (UK) Competent Body, NVLAP (USA) Accreditation Body & ACA/AUSTEL (Australia)
- Recognized/Listed by FCC (USA), Industry Canada (Canada)
- All test results contained in this engineering test report are traceable to National Institute of Standards and Technology (NIST)

6.9. TRANSMITTER SPURIOUS/HARMONIC RADIATED EMISSIONS @ FCC 90.210

6.9.1. Limits @ FCC 90.210

Emissions shall be attenuated below the mean output power of the transmitter as follows:

Frequency Range (MHz)	Maximum Authorized BW (KHz)	Channel Spacing (KHz)	Recommended Frequency Deviation (KHz)	FCC Applicable Mask
403-512	20.0	25.0	5.0	<ul style="list-style-type: none"> 90.210(b): Mask B – Voice 90.210(c): Mask C – Data

6.9.2. Method of Measurements

Refer to Exhibit 8, Sec. 8.5 of this report for measurement details

6.9.3. Test Equipment List

Test Instruments	Manufacturer	Model No.	Serial No.	Frequency Range
Spectrum Analyzer/ EMI Receiver	Advantest	R3271	15050203	100 Hz to 32 GHz with external mixer for frequency above 32 GHz
Microwave Amplifier	Hewlett Packard	HP 83017A		1 GHz to 26.5 GHz
Active Loop Antenna	EMCO	6507	8906-1167	1 kHz – 30 MHz
Biconilog Antenna	EMCO	3143	1029	20 MHz to 2 GHz
Horn Antenna	EMCO	3155	9701-5061	1 GHz – 18 GHz
Horn Antenna	EMCO	3160-09	..	18 GHz – 26.5 GHz
Horn Antenna	EMCO	3160-10	..	26.5 GHz – 40 GHz
Mixer	Tektronix	118-0098-00	..	18 GHz – 26.5 GHz
Mixer	Tektronix	119-0098-00	..	26.5 GHz – 40 GHz

ULTRATECH GROUP OF LABS

3000 Bristol Circle, Oakville, Ontario, Canada L6H 6G4
Tel. #: 905-829-1570, Fax. #: 905-829-8050, Email: vhk.ultratech@sympatico.ca, Website: <http://www.ultratech-labs.com>

File #: MIC23-FTX
September 5, 2000

- Assessed by ITI (UK) Competent Body, NVLAP (USA) Accreditation Body & ACA/AUSTEL (Australia)
- Recognized/Listed by FCC (USA), Industry Canada (Canada)
- All test results contained in this engineering test report are traceable to National Institute of Standards and Technology (NIST)

6.9.4. Test Arrangement

The following drawing shows details of the test setup for radiated emissions measurements

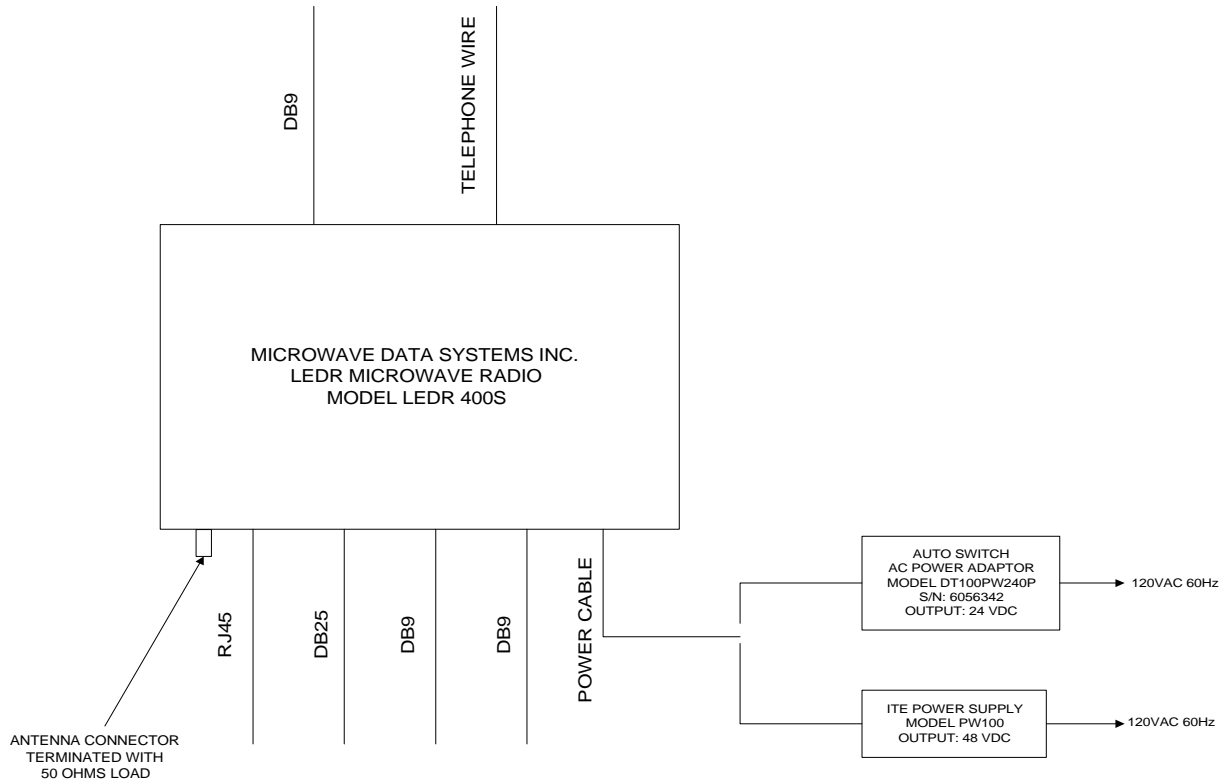

ULTRATECH GROUP OF LABS

3000 Bristol Circle, Oakville, Ontario, Canada L6H 6G4
Tel. #: 905-829-1570, Fax. #: 905-829-8050, Email: vhk.ultratech@sympatico.ca, Website: <http://www.ultratech-labs.com>

File #: MIC23-FTX
September 5, 2000

- Assessed by ITI (UK) Competent Body, NVLAP (USA) Accreditation Body & ACA/AUSTEL (Australia)
- Recognized/Listed by FCC (USA), Industry Canada (Canada)
- All test results contained in this engineering test report are traceable to National Institute of Standards and Technology (NIST)

6.9.5. Test Data

Remarks:

- The Radiated emissions were performed at 3 meters distance.

6.9.5.1. Near Lowest Frequency (409 MHz)

Fundamental Frequency: 409 MHz							
RF Output Power: 5.8 Watts Peak, 1 Watt Average							
Modulation: 32QAM modulation with random data @ 64 kbps							
FREQUENCY (MHz)	RF Field Level @ 3m (dBuV/m)	RF Power Level (dBm)	DETECTOR USED (PEAK/QP)	ANTENNA PLANE (H/V)	LIMIT @3m (dBm)	MARGIN (dB)	PASS/ FAIL
818	52.77	-44.73	PEAK	V	-13.0	-31.7	PASS
818	53.87	-43.63	PEAK	H	-13.0	-30.6	PASS
The emissions were scanned from 10 MHz to 5 GHz and all emissions less 40 dB below the limits were recorded.							

6.9.5.2. Near Middle Frequency (450.9 MHz)

Fundamental Frequency: 450.9 MHz							
RF Output Power: 4.4 Watts Peak, 1 Watt Average							
Modulation: 32QAM modulation with random data @ 64 kbps							
FREQUENCY (MHz)	RF Field Level @3m (dBuV/m)	RF Power Level (dBm)	DETECTOR USED (PEAK/QP)	ANTENNA PLANE (H/V)	LIMIT @3m (dBm)	MARGIN (dB)	PASS/ FAIL
901.8	50.75	-46.75	PEAK	V	-13.0	-33.8	PASS
901.8	49.35	-48.15	PEAK	H	-13.0	-35.2	PASS
The emissions were scanned from 10 MHz to 5 GHz and all emissions less 40 dB below the limits were recorded.							

6.9.5.3. Near Highest Frequency (510 MHz)

Fundamental Frequency: 510 MHz							
RF Output Power: 5.8 Watts Peak, , 1 Watt Average							
Modulation: 32QAM modulation with random data @ 64 kbps							
FREQUENCY (MHz)	RF Field Level @3m (dBuV/m)	RF Power Level (dBm)	DETECTOR USED (PEAK/QP)	ANTENNA PLANE (H/V)	LIMIT @3m (dBm)	MARGIN (dB)	PASS/ FAIL
1020	44.90	-52.60	PEAK	V	-13.0	-39.6	PASS
1020	45.94	-51.56	PEAK	H	-13.0	-38.6	PASS
The emissions were scanned from 10 MHz to 5 GHz and all emissions less 40 dB below the limits were recorded.							

6.9.6. Photographs of Test Setup

Please refer to Exhibit 10 Photos # 1 to # 2 for details of test setup.

ULTRATECH GROUP OF LABS

3000 Bristol Circle, Oakville, Ontario, Canada L6H 6G4
Tel. #: 905-829-1570, Fax. #: 905-829-8050, Email: vhk.ultratech@sympatico.ca, Website: <http://www.ultratech-labs.com>

File #: MIC23-FTX
September 5, 2000

- Assessed by ITI (UK) Competent Body, NVLAP (USA) Accreditation Body & ACA/AUSTEL (Australia)
- Recognized/Listed by FCC (USA), Industry Canada (Canada)
- All test results contained in this engineering test report are traceable to National Institute of Standards and Technology (NIST)

6.10. TRANSIENT FREQUENCY BEHAVIOR @ 90.214

6.10.1. Limits

Transient frequencies must be within the maximum frequency difference limits during the time intervals indicated:

Transient Frequency Behavior for equipment Designed to Operate on 25 KHz Channels

Time Interval ^{1,2}	Maximum Frequency Difference ³	All Equipment
		421 to 512 MHz
t1 ⁴	± 25 KHz	10.0 ms
t2	± 12.5 KHz	25.0 ms
t3 ⁴	± 25 KHz	10.0 ms

- (1) t_{on}: the instant when a 1 KHz test signal is completely suppressed, including any capture time due to phasing.
t₁: time period immediately after t_{on}
t₂: time period after t₁
t₃: time period from the instant when the transmitter is turned off until t_{off}
t_{off}: the instant when the 1 KHz test signal starts to rise.
- (2) During the time from the end of t₂ to the beginning of t₃, the frequency difference must not exceed the limits specified in @ 90.213
- (3) Difference between the actual transmitter frequency and assigned transmitter frequency.
- (4) If the transmitter carrier output power rating is 6 watts or less, the frequency difference during this time period may exceed the maximum frequency difference for this time period.

6.10.2. Method of Measurements

Refer to Exhibit 8, Sec. 8.6 of this test report and ANSI/TIA/EIA - 603 - 1992, Sec. 2.2.19, Page 83

6.10.3. Test Equipment List

Test Instruments	Manufacturer	Model No.	Serial No.	Frequency Range
RF Synthesized Signal Generator	Fluke	6061A	...	10 kHz – 1GHz 13 dBm output max. @ 50 Ohms
Communication Analyzer (Test Receiver)	Rohde & Schwarz	SMFP2	879988/05 7	400 GHz including SINAD, S/N, Modulation meters, AF & RF signal generators and etc....
Network Combiner	Mini-circuit	15542	...	DC to 22 GHz (7 dB insertion loss)
Digital Storage Scope	Phillips	3320A	DQ 646	DC - 5 MHz
67297 RF Detector,	Herotex	DZ122-553	63400	..

ULTRATECH GROUP OF LABS

3000 Bristol Circle, Oakville, Ontario, Canada L6H 6G4
Tel. #: 905-829-1570, Fax. #: 905-829-8050, Email: vhk.ultratech@sympatico.ca, Website: <http://www.ultratech-labs.com>

File #: MIC23-FTX
September 5, 2000

- Assessed by ITI (UK) Competent Body, NVLAP (USA) Accreditation Body & ACA/AUSTEL (Australia)
- Recognized/Listed by FCC (USA), Industry Canada (Canada)
- All test results contained in this engineering test report are traceable to National Institute of Standards and Technology (NIST)

6.10.4. Test Arrangement

The following drawings show details of the test setup for radiated emissions measurements

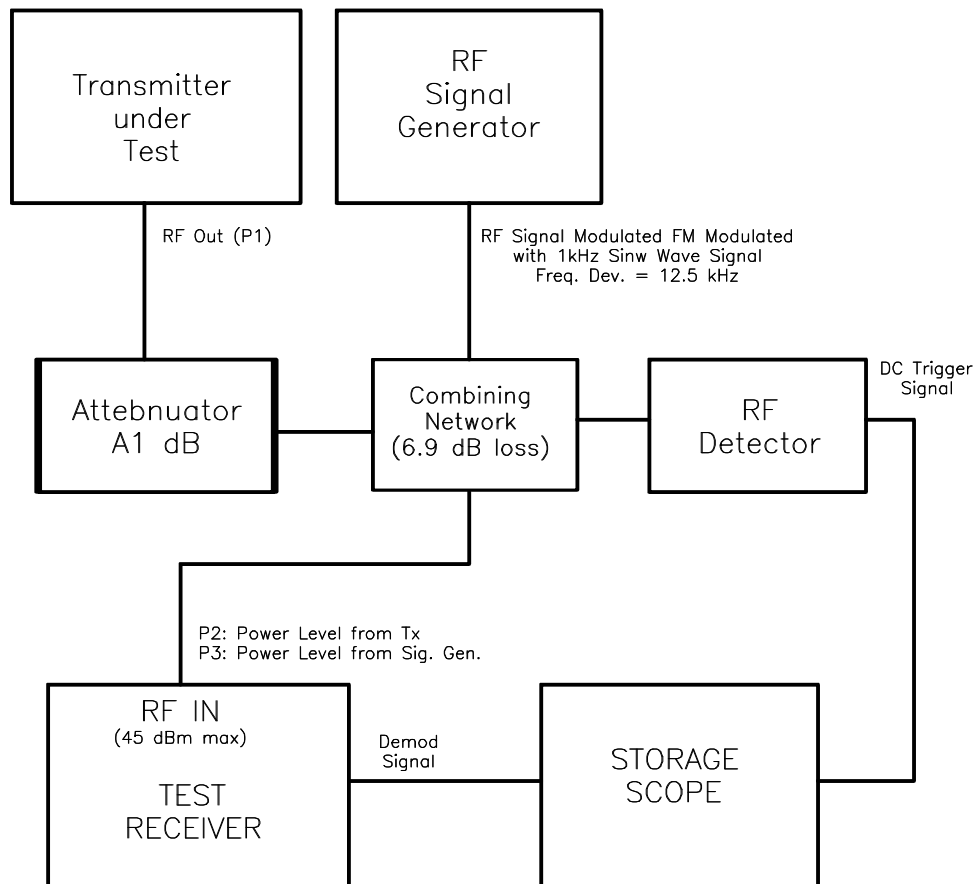

ULTRATECH GROUP OF LABS

3000 Bristol Circle, Oakville, Ontario, Canada L6H 6G4
Tel. #: 905-829-1570, Fax. #: 905-829-8050, Email: vhk.ultratech@sympatico.ca, Website: <http://www.ultratech-labs.com>

File #: MIC23-FTX
September 5, 2000

- Assessed by ITI (UK) Competent Body, NVLAP (USA) Accreditation Body & ACA/AUSTEL (Australia)
- Recognized/Listed by FCC (USA), Industry Canada (Canada)
- All test results contained in this engineering test report are traceable to National Institute of Standards and Technology (NIST)

6.10.5. Test Data

6.10.5.1. 25 kHz Channel Spacing Operation

6.10.5.1.1. Test Configuration #1: Unmodulated

Time Interval	Transient Frequency	Transient Frequency Limit
t1 (10 mS) Switch On Condition	0	25 kHz or no limit for RF Output PWR < 6 Watts
t2 (25 mS) Switch On Condition	0	12.5 kHz
After t2 (10 mS) Switch On Condition	0	FCC Limit = ± 1022.5 Hz (2.5 ppm @ 409 MHz)
Before t3 (10 mS) Switch Off Condition	0	FCC Limit = ± 1022.5 Hz (2.5 ppm @ 409 MHz)
t3 (10 mS) Switch Off Condition	0	25 kHz or no limit for RF Output PWR < 6 Watts

6.10.5.2. Test Configuration #2: 32 QAM modulation with random data @ 64 kbps

Time Interval	Transient Frequency	Transient Frequency Limit
t1 (10 mS) Switch On Condition	0	25 kHz or no limit for RF Output PWR < 6 Watts
t2 (25 mS) Switch On Condition	0	12.5 kHz
After t2 (10 mS) Switch On Condition	0	FCC Limit = ± 1022.5 Hz (2.5 ppm @ 409 MHz)
Before t3 (10 mS) Switch Off Condition	0	FCC Limit = ± 1022.5 Hz (2.5 ppm @ 409 MHz)
t3 (10 mS) Switch Off Condition	0	25 kHz or no limit for RF Output PWR < 6 Watts

6.10.6. Plots

Please refer to plots # 10 to 11 in Exhibit 9 for details of measurements

ULTRATECH GROUP OF LABS

3000 Bristol Circle, Oakville, Ontario, Canada L6H 6G4
Tel. #: 905-829-1570, Fax. #: 905-829-8050, Email: vhk.ultratech@sympatico.ca, Website: <http://www.ultratech-labs.com>

File #: MIC23-FTX
September 5, 2000

- Assessed by ITI (UK) Competent Body, NVLAP (USA) Accreditation Body & ACA/AUSTEL (Australia)
- Recognized/Listed by FCC (USA), Industry Canada (Canada)
- All test results contained in this engineering test report are traceable to National Institute of Standards and Technology (NIST)

EXHIBIT 7. MEASUREMENT UNCERTAINTY

The measurement uncertainties stated were calculated in accordance with the requirements of NIST Technical Note 1297 and NIS 81 (1994)

7.1. RADIATED EMISSION MEASUREMENT UNCERTAINTY

CONTRIBUTION (Radiated Emissions)	PROBABILITY DISTRIBUTION	UNCERTAINTY (+ dB)	
		3 m	10 m
Antenna Factor Calibration	Normal (k=2)	± 1.0	± 1.0
Cable Loss Calibration	Normal (k=2)	± 0.3	± 0.5
EMI Receiver specification	Rectangular	± 1.5	± 1.5
Antenna Directivity	Rectangular	+0.5	+0.5
Antenna factor variation with height	Rectangular	± 2.0	± 0.5
Antenna phase center variation	Rectangular	0.0	± 0.2
Antenna factor frequency interpolation	Rectangular	± 0.25	± 0.25
Measurement distance variation	Rectangular	± 0.6	± 0.4
Site imperfections	Rectangular	± 2.0	± 2.0
Mismatch: Receiver VRC $\Gamma_1 = 0.2$ Antenna VRC $\Gamma_R = 0.67(\text{Bi}) 0.3 (\text{Lp})$ Uncertainty limits $20\text{Log}(1 \pm \Gamma_1 \Gamma_R)$	U-Shaped	+1.1 -1.25	± 0.5
System repeatability	Std. Deviation	± 0.5	± 0.5
Repeatability of EUT		-	-
Combined standard uncertainty	Normal	+2.19 / -2.21	+1.74 / -1.72
Expanded uncertainty U	Normal (k=2)	+4.38 / -4.42	+3.48 / -3.44

Calculation for maximum uncertainty when 3m biconical antenna including a factor of k=2 is used:

$$U = 2u_c(y) = 2x(+2.19) = +4.38 \text{ dB} \quad \text{And} \quad U = 2u_c(y) = 2x(-2.21) = -4.42 \text{ dB}$$

ULTRATECH GROUP OF LABS

3000 Bristol Circle, Oakville, Ontario, Canada L6H 6G4
Tel. #: 905-829-1570, Fax. #: 905-829-8050, Email: vhk.ultratech@sympatico.ca, Website: <http://www.ultratech-labs.com>

File #: MIC23-FTX
September 5, 2000

- Assessed by ITI (UK) Competent Body, NVLAP (USA) Accreditation Body & ACA/AUSTEL (Australia)
- Recognized/Listed by FCC (USA), Industry Canada (Canada)
- All test results contained in this engineering test report are traceable to National Institute of Standards and Technology (NIST)

EXHIBIT 8. MEASUREMENT METHODS

8.1. EFFECTIVE RADIATED POWER (ERP) MEASUREMENTS

- The following shall be applied to the combination(s) of the radio device and its intended antenna(e).
- If the RF level is user adjustable, all measurements shall be made with the highest power level available to the user for that combination.
- The following method of measurement shall apply to both conducted and radiated measurements.
- The radiated measurements are performed at the Ultratech Calibrated Open Field Test Site.
- The measurement shall be performed using normal operation of the equipment with modulation.

Test procedure shall be as follows:

Step 1: Duty Cycle measurements

- Using a spectrum analyzer with the frequency span set to 0 Hz and the sweep time set at a suitable value to capture the envelope peaks and the duty cycle of the transmitter output signal;
- The duty cycle of the transmitter, $x = T_x \text{ on} / (T_x \text{ on} + T_x \text{ off})$ with $0 < x < 1$, is measure and recorded in the test report. For the purpose of testing, the equipment shall be operated with a duty cycle that is equal or more than 0.1.

Step 2: Calculation of Average EIRP. See Figure 1

- The average output power of the transmitter shall be determined using a wideband, calibrated RF power meter with the power sensor with an integration period that exceeds the repetition period of the transmitter by a factor 5 or more. The observed value shall be recorded as “A” (in dBm);
- The e.i.r.p. shall be calculated from the above measured power output “A”, the observed duty cycle x, and the applicable antenna assembly gain “G” in dBi, according to the formula:

$$\text{EIRP} = \text{A} + \text{G} + 10\log(1/x)$$

Figure 1.

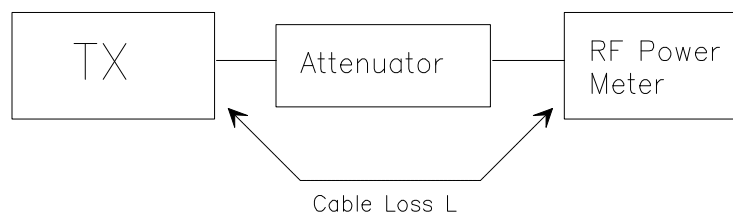

Step 3: Substitution Method. See Figure 2

- The measurements was performed in the absence of modulation (un-modulated)
- Test was performed at listed 3m open area test site (listed with FCC, IC, ITI, NVLAP, ACA & VCCI).
- The transmitter under test was placed at the specified height on a non-conducting turntable (80 cm height)
- The dipole test antenna was used and tuned to the transmitter carrier frequency.
- The spectrum analyzer was tuned to transmitter carrier frequency. The test antenna was lowered or raised from 1 to 4 meters until the maximum signal level was detected.
- The transmitter was rotated through 360° about a vertical axis until a higher maximum signal was received.
- The test antenna was lowered or raised again from 1 to 4 meters until a maximum was obtained. This level was recorded.
- The substitution dipole antenna and the signal generator replaced the transmitter and antenna under test in the same position, and the substitution dipole antenna was placed in vertical polarization. The test dipole antenna was lowered or raised as necessary to ensure that the maximum signal is stilled received.

ULTRATECH GROUP OF LABS

3000 Bristol Circle, Oakville, Ontario, Canada L6H 6G4
Tel. #: 905-829-1570, Fax. #: 905-829-8050, Email: vhk.ultratech@sympatico.ca, Website: <http://www.ultratech-labs.com>

File #: MIC23-FTX
September 5, 2000

- Assessed by ITI (UK) Competent Body, NVLAP (USA) Accreditation Body & ACA/AUSTEL (Australia)
- Recognized/Listed by FCC (USA), Industry Canada (Canada)
- All test results contained in this engineering test report are traceable to National Institute of Standards and Technology (NIST)

- (i) The input signal to the substitution antenna was adjusted in level until an equal or a known related level to that detected from the transmitter was obtained in the test receiver. The maximum carrier radiated power is equal to the power supply by the generator.
- (j) The substitution antenna gain and cable loss were added to the signal generator level for the corrected ERP level.
- (k) Repeat steps (c) to (j) with the substitution antenna oriented in horizontal polarization.
- (l) Actual gain of the EUT's antenna is the difference of the measured ERP and measured RF power at the RF port. Correct the antenna gain if necessary.

Figure 2

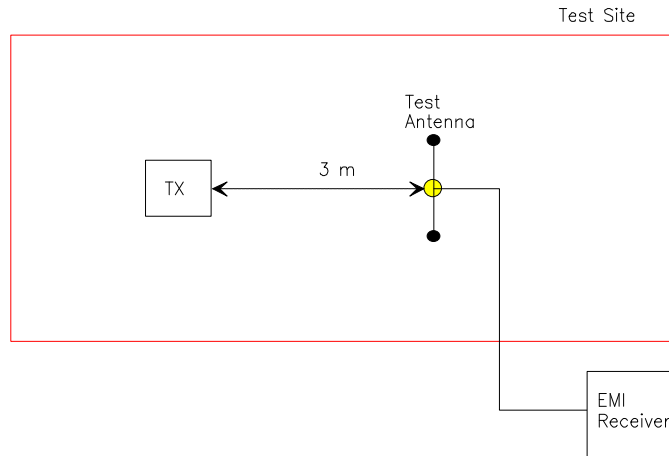
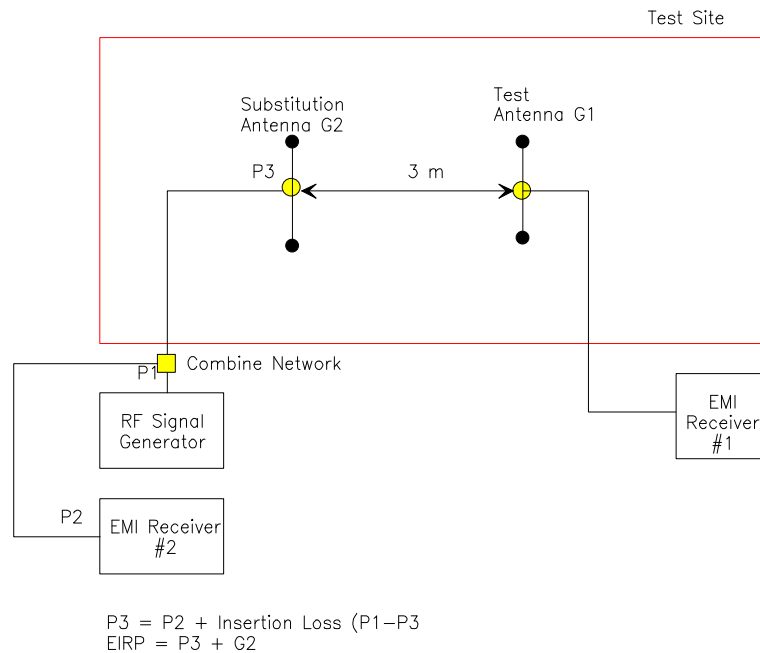

Figure 3



8.2. FREQUENCY STABILITY

Refer to FCC @ 2.995.

- (a) The frequency stability shall be measured with variation of ambient temperature as follows: From -30 to +50 centigrade except that specified in subparagraph (2) & (3) of this paragraph.
- (b) Frequency measurements shall be made at extremes of the specified temperature range and at intervals of not more than 10 centigrade through the range. A period of time sufficient to stabilize all of the components of the oscillator circuit at each temperature level shall be allowed prior to frequency measurement. The short term transient effects on the frequency of the transmitter due to keying (except for broadcast transmitters) and any heating element cycling normally occurring at each ambient temperature level also shall be shown. Only the portion or portions of the transmitter containing the frequency determining and stability circuitry need be subjected to the temperature variation test.
- (d) The frequency stability supply shall be measured with variation of primary supply voltage as follows:
 - (1) Vary primary supply voltage from 85 to 115 percent of the nominal value for other than hand carried battery equipment.
 - (2) For hand carried, battery powered equipment, reduce primary supply voltage to the battery operating end point which shall be specified by the manufacturer.
 - (3) The supply voltage shall be measured at the input to the cable normally provide with the equipment, or at the power supply terminals if cables are not normally provided. Effects on frequency of transmitter keying (except for broadcast transmitters) and any heating element cycling at the nominal supply voltage and at each extreme also shall be shown.
- (f) When deemed necessary, the Commission may require tests of frequency stability under conditions in addition to those specifically set out in paragraphs (a), (b), (c) and (d) of this section. (For example, measurements showing the effect of proximity to large metal objects, or of various types of antennas, may be required for portable equipment).

ULTRATECH GROUP OF LABS

3000 Bristol Circle, Oakville, Ontario, Canada L6H 6G4
Tel. #: 905-829-1570, Fax. #: 905-829-8050, Email: vhk.ultratech@sympatico.ca, Website: <http://www.ultratech-labs.com>

File #: MIC23-FTX
September 5, 2000

- Assessed by ITI (UK) Competent Body, NVLAP (USA) Accreditation Body & ACA/AUSTEL (Australia)
- Recognized/Listed by FCC (USA), Industry Canada (Canada)
- All test results contained in this engineering test report are traceable to National Institute of Standards and Technology (NIST)

8.3. EMISSION MASK

Voice or Digital Modulation Through a Voice Input Port @ 2.989(c)(i):- The transmitter was modulated by a 2.5 KHz tone signal at an input level 16 dB greater than that required to produce 50% modulation (e.g.: ± 2.5 KHz peak deviation at 1 KHz modulating frequency). The input level was established at the frequency of maximum response of the audio modulating circuit.

Digital Modulation Through a Data Input Port @ 2.989(h):- Transmitters employing digital modulation techniques - when modulated by an input signal such that its amplitude and symbol rate represent the maximum rated conditions under which the equipment will be operated. The signal shall be applied through any filter networks, pseudo-random generators or other devices required in normal service. Additionally, the Emission Masks shall be shown for operation with any devices used for modifying the spectrum when such devices are operational at the discretion of the user.

The following spectrum analyzer bandwidth shall be used for measurement of Emission Mask/Out-of-Band Emission Measurements:

- (1) For 25 kHz Channel Spacing: RBW = 300 Hz
- (2) For 12.5 kHz or 6.25 kHz Channel Spacings: RBW = 100 Hz

The all cases the Video Bandwidth shall be equal or greater than the measuring bandwidth.

8.4. SPURIOUS EMISSIONS (CONDUCTED)

With transmitter modulation characteristics described in Out-of-Band Emissions measurements @ 2.989, the transmitter spurious and harmonic emissions were scanned. The spurious and harmonic emissions were measured with the Spectrum Analyzer controls set as RBW = 30 kHz minimum, VBW \geq RBW and SWEEP TIME = AUTO). The transmitter was operated at a full rated power output, and modulated as follows:

FCC CFR 47, Para. 2.997 - Frequency spectrum to be investigated:- The spectrum was investigated from the lowest radio generated in the equipment up to at least the 10th harmonic of the carrier frequency or to the highest frequency practicable in the present state of the art of measuring techniques, whichever is lower. Particular attention should be paid to harmonics and subharmonics of the carrier frequency. Radiation at the frequencies of multiplier stages should be checked. The amplitude of spurious emissions which are attenuated more than 20 dB below the permissible value need not be reported.

FCC CFR 47, Para. 2.991 - Spurious Emissions at Antenna Terminal:- The radio frequency voltage or powers generated within the equipment and appearing on a spurious frequency shall be checked at the equipment output terminals when properly loaded with a suitable artificial antenna. Curves or equivalent data shall show the magnitude of the harmonic and other spurious emission that can be detected when the equipment is operated under the conditions specified in 2.989 as appropriate. The magnitude of spurious emissions which are attenuated more than 20 dB below the permissible value need not be specified.

ULTRATECH GROUP OF LABS

3000 Bristol Circle, Oakville, Ontario, Canada L6H 6G4
Tel. #: 905-829-1570, Fax. #: 905-829-8050, Email: vhk.ultratech@sympatico.ca, Website: <http://www.ultratech-labs.com>

File #: MIC23-FTX
September 5, 2000

- Assessed by ITI (UK) Competent Body, NVLAP (USA) Accreditation Body & ACA/AUSTEL (Australia)
- Recognized/Listed by FCC (USA), Industry Canada (Canada)
- All test results contained in this engineering test report are traceable to National Institute of Standards and Technology (NIST)

8.5. SPURIOUS EMISSIONS (RADIATED)

With transmitter modulation characteristics described in Out-of-Band Emissions measurements @ 2.989, the transmitter spurious and harmonic emissions were scanned. The spurious and harmonic emissions were measured with the Spectrum Analyzer controls set as RBW = 100 kHz minimum , VBW \geq RBW and SWEEP TIME = AUTO). The transmitter was operated at a full rated power output, and modulated as follows:

FCC CFR 47, Para. 2.997 - Frequency spectrum to be investigated:- The spectrum was investigated from the lowest radio generated in the equipment up to at least the 10th harmonic of the carrier frequency or to the highest frequency practicable in the present state of the art of measuring techniques, whichever is lower. Particular attention should be paid to harmonics and subharmonics of the carrier frequency. Radiation at the frequencies of multiplier stages should be checked. The amplitude of spurious emissions which are attenuated more than 20 dB below the permissible value need not be reported.

FCC CFR 47, Para. 2.993 - Field Strength Spurious Emissions

- (a) Measurements was made to detect spurious emissions radiated directly from the cabinet, control circuits, power leads, or intermediate circuit elements under normal conditions of installation and operation. Curves or equivalent data were supplied showing the magnitude of each harmonic and other spurious emission. For this test, single sideband, independent sideband, and controlled carrier transmitters shall be modulated under the conditions specified in paragraph 2.989(c) as appropriate. For equipment operating on frequencies below 1 GHz , an Open Field Test is normally required, with the measuring instrument antenna located in the far field at all test frequencies. In event it is either impractical or impossible to make open field measurements (e.g. a broadcast transmitter installed in a building) measurement will be accepted of the equipment as installed. Such measurements must be accompanied by a description of the site where the measurements were made showing the location of any possible source of reflections which might distort the field strength measurements. Information submitted shall include the relative radiated power of each spurious emission with the reference to the rated power output of the transmitter, assuming all emissions are radiated from half-wave dipole antennas.
- (b) Measurements specified in paragraph (a) of this section shall be made for the following equipment:
- (1) Those in which the spurious emission are required to be 60 dB or more below the mean power of the transmitter.
 - (2) All equipment operating on frequencies higher than 25 MHz
 - (3) All equipment where the antenna is an integral part of, and attached directly to the transmitter.
 - (4) Other types of equipment as required, when deemed necessary by the Commission.

Maximizing RF Emission Level:

- (a) The measurements was performed with standard modulation
- (b) Test was performed at listed 3m open area test site (listed with FCC, IC, ITI, NVLAP, ACA & VCCI).
- (c) The transmitter under test was placed at the specified height on a non-conducting turntable (80 cm height)
- (d) The biconilog Antenna (20 MHz to 1 GHz) or Horn Antenna (1 GHz to 18 GHz) was used for measuring.
- (e) The spectrum analyzer was tuned to transmitter carrier frequency. The test antenna was lowered or raised from 1 to 4 meters until the maximum signal level was detected.
- (f) The transmitter was rotated through 360° about a vertical axis until a higher maximum signal was received.
- (g) The test antenna was lowered or raised again from 1 to 4 meters until a maximum was obtained. This level was recorded.
- (h) The recorded reading was corrected to the true field strength level by adding the antenna factor, cable loss and subtracting the pre-amplifier gain.
- (i) The field strength level measured at 3m is converted to the power in dBm by subtracting a constant factor of 97.5 dB

ULTRATECH GROUP OF LABS

3000 Bristol Circle, Oakville, Ontario, Canada L6H 6G4
Tel. #: 905-829-1570, Fax. #: 905-829-8050, Email: vhk.ultratech@sympatico.ca, Website: <http://www.ultratech-labs.com>

File #: MIC23-FTX
September 5, 2000

- Assessed by ITI (UK) Competent Body, NVLAP (USA) Accreditation Body & ACA/AUSTEL (Australia)
- Recognized/Listed by FCC (USA), Industry Canada (Canada)
- All test results contained in this engineering test report are traceable to National Institute of Standards and Technology (NIST)

METHOD OF CALCULATION FOR TRANSMITTED POWER (P) FROM THE MEASURED FIELD STRENGTH LEVEL (E):

According to IEC 801-3, the power density can be calculated as follows:

$$S = P / (4 \times \text{PI} \times D^2)$$

Where: S: Power density in watts per square feet
P: Transmitted power in watts
PI: 13.1415
D: Distance in meters

The power density S (W/m²) and electric field E (V/m) is related by:

$$S = E^2 / (120 \times \text{PI})$$

Accordingly, the field intensity of isotropic radiator in free space can be expressed as follows:

$$E = (30 \times P)^{1/2} / D = 5.5 \times (P)^{1/2} / D$$

For Halfwave dipole antenna or other antennas correlated to dipole in direction of maximum radiation:

$$S = (1.64 \times P) / (4 \times \text{PI} \times D^2)$$
$$E = (49.2 \times P)^{1/2} / D = 7.01 \times (P)^{1/2} / D$$

$P = (E \times D / 7.01)^2$

Calculation of transmitted power P (dBm) given a measured field intensity E (dBμV/m):

$$\begin{aligned} P(W) &= [E(V/m) \times D / 7.01]^2 \\ P(mW) &= P(W) \times 1000 \\ \Rightarrow P(dBm) &= 10 \log P(mW) \\ &= 20 \log E(V/m) + 20 \log(D) - 20 \log(7.01) + 10 \log 1000 \\ &= E(dBV/m) + 20 \log D + 13 \\ &= E(dB\mu V/m) - 120 + 20 \log(D) + 13 \\ &= E(dB\mu V/m) + 20 \log(D) - 107 \end{aligned}$$

The Transmitted Power @ D = 3 Meters

$P(dBm) = E(dB\mu V/m) - 97.5$

ULTRATECH GROUP OF LABS

3000 Bristol Circle, Oakville, Ontario, Canada L6H 6G4
Tel. #: 905-829-1570, Fax. #: 905-829-8050, Email: vhk.ultratech@sympatico.ca, Website: <http://www.ultratech-labs.com>

File #: MIC23-FTX
September 5, 2000

- Assessed by ITI (UK) Competent Body, NVLAP (USA) Accreditation Body & ACA/AUSTEL (Australia)
- Recognized/Listed by FCC (USA), Industry Canada (Canada)
- All test results contained in this engineering test report are traceable to National Institute of Standards and Technology (NIST)

8.6. TRANSIENT FREQUENCY BEHAVIOR

1. Connect the transmitter under tests as shown in the above block diagram
2. Set the signal generator to the assigned frequency and modulate with a 1 kHz tone at ± 12.5 kHz deviation and its output level to be 50 dB below the transmitter rf output at the test receiver end.
3. Set the horizontal sweep rate on the storage scope to 10 milliseconds per division and adjust the display to continuously view the 1000 Hz tone from the Demodulator Output Port (DOP) of the Test Receiver. Adjust the vertical scale amplitude control of the scope to display the 1000 Hz at ± 4 divisions vertical Center at the display.
4. Adjust the scope so it will trigger on an increasing magnitude from the RF trigger signal of the transmitter under test when the transmitter was turned on. Set the controls to store the display.
5. The output at the DOP, due to the change in the ratio of the power between the signal generator input power and transmitter output power will, because of the capture effect of the test receiver, produce a change in display: For the first part of the sweep it will show the 1 kHz test signal. Then once the receiver's demodulator has been captured by the transmitter power, the display will show the frequency difference from the assigned frequency to the actual transmitter frequency versus time. The instant when the 1 kHz test signal is completely suppressed (including any capture time due to phasing) is considered to be t_{on} . The trace should be maintained within the allowed divisions during the period t_1 and t_2 .
6. During the time from the end of t_2 to the beginning of t_3 the frequency difference should not exceed the limits set by the FCC in Part 90.214 and the outlined in the Carrier Frequency Stability sections. The allowed limit is equal to FCC frequency tolerance limits specified in FCC 90.213.
7. Repeat the above steps when the transmitter was turned off for measuring t_3 .

ULTRATECH GROUP OF LABS

3000 Bristol Circle, Oakville, Ontario, Canada L6H 6G4
Tel. #: 905-829-1570, Fax. #: 905-829-8050, Email: vhk.ultratech@sympatico.ca, Website: <http://www.ultratech-labs.com>

File #: MIC23-FTX
September 5, 2000

- Assessed by ITI (UK) Competent Body, NVLAP (USA) Accreditation Body & ACA/AUSTEL (Australia)
- Recognized/Listed by FCC (USA), Industry Canada (Canada)
- All test results contained in this engineering test report are traceable to National Institute of Standards and Technology (NIST)

EXHIBIT 9. MEASUREMENT DATA PLOTS

ULTRATECH GROUP OF LABS

3000 Bristol Circle, Oakville, Ontario, Canada L6H 6G4
Tel. #: 905-829-1570, Fax. #: 905-829-8050, Email: vhk.ultratech@sympatico.ca, Website: <http://www.ultratech-labs.com>

File #: MIC23-FTX
September 5, 2000

- Assessed by ITI (UK) Competent Body, NVLAP (USA) Accreditation Body & ACA/AUSTEL (Australia)
- Recognized/Listed by FCC (USA), Industry Canada (Canada)
- *All test results contained in this engineering test report are traceable to National Institute of Standards and Technology (NIST)*

EXHIBIT 10. TEST SETUP PHOTOS

ULTRATECH GROUP OF LABS

3000 Bristol Circle, Oakville, Ontario, Canada L6H 6G4
Tel. #: 905-829-1570, Fax. #: 905-829-8050, Email: vhk.ultratech@sympatico.ca, Website: <http://www.ultratech-labs.com>

File #: MIC23-FTX
September 5, 2000

- Assessed by ITI (UK) Competent Body, NVLAP (USA) Accreditation Body & ACA/AUSTEL (Australia)
- Recognized/Listed by FCC (USA), Industry Canada (Canada)
- *All test results contained in this engineering test report are traceable to National Institute of Standards and Technology (NIST)*

EXHIBIT 11. EXTERNAL EUT PHOTOS

ULTRATECH GROUP OF LABS

3000 Bristol Circle, Oakville, Ontario, Canada L6H 6G4
Tel. #: 905-829-1570, Fax. #: 905-829-8050, Email: vhk.ultratech@sympatico.ca, Website: <http://www.ultratech-labs.com>

File #: MIC23-FTX
September 5, 2000

- Assessed by ITI (UK) Competent Body, NVLAP (USA) Accreditation Body & ACA/AUSTEL (Australia)
- Recognized/Listed by FCC (USA), Industry Canada (Canada)
- *All test results contained in this engineering test report are traceable to National Institute of Standards and Technology (NIST)*

EXHIBIT 12. INTERNAL EUT PHOTOS

ULTRATECH GROUP OF LABS

3000 Bristol Circle, Oakville, Ontario, Canada L6H 6G4
Tel. #: 905-829-1570, Fax. #: 905-829-8050, Email: vhk.ultratech@sympatico.ca, Website: <http://www.ultratech-labs.com>

File #: MIC23-FTX
September 5, 2000

- Assessed by ITI (UK) Competent Body, NVLAP (USA) Accreditation Body & ACA/AUSTEL (Australia)
- Recognized/Listed by FCC (USA), Industry Canada (Canada)
- *All test results contained in this engineering test report are traceable to National Institute of Standards and Technology (NIST)*

EXHIBIT 13. COVER LETTERS

ULTRATECH GROUP OF LABS

3000 Bristol Circle, Oakville, Ontario, Canada L6H 6G4

Tel. #: 905-829-1570, Fax. #: 905-829-8050, Email: vhk.ultratech@sympatico.ca, Website: <http://www.ultratech-labs.com>

File #: MIC23-FTX
September 5, 2000

- Assessed by ITI (UK) Competent Body, NVLAP (USA) Accreditation Body & ACA/AUSTEL (Australia)
- Recognized/Listed by FCC (USA), Industry Canada (Canada)
- *All test results contained in this engineering test report are traceable to National Institute of Standards and Technology (NIST)*

EXHIBIT 14. ATTESTATION STATEMENTS

None.

ULTRATECH GROUP OF LABS

3000 Bristol Circle, Oakville, Ontario, Canada L6H 6G4
Tel. #: 905-829-1570, Fax. #: 905-829-8050, Email: vhk.ultratech@sympatico.ca, Website: <http://www.ultratech-labs.com>

File #: MIC23-FTX
September 5, 2000

- Assessed by ITI (UK) Competent Body, NVLAP (USA) Accreditation Body & ACA/AUSTEL (Australia)
- Recognized/Listed by FCC (USA), Industry Canada (Canada)
- *All test results contained in this engineering test report are traceable to National Institute of Standards and Technology (NIST)*

EXHIBIT 15. APPLICATION FORMS

ULTRATECH GROUP OF LABS

3000 Bristol Circle, Oakville, Ontario, Canada L6H 6G4
Tel. #: 905-829-1570, Fax. #: 905-829-8050, Email: vhk.ultratech@sympatico.ca, Website: <http://www.ultratech-labs.com>

File #: MIC23-FTX
September 5, 2000

- Assessed by ITI (UK) Competent Body, NVLAP (USA) Accreditation Body & ACA/AUSTEL (Australia)
- Recognized/Listed by FCC (USA), Industry Canada (Canada)
- *All test results contained in this engineering test report are traceable to National Institute of Standards and Technology (NIST)*

EXHIBIT 16. ID LABEL/LOCATION INFO

ULTRATECH GROUP OF LABS

3000 Bristol Circle, Oakville, Ontario, Canada L6H 6G4
Tel. #: 905-829-1570, Fax. #: 905-829-8050, Email: vhk.ultratech@sympatico.ca, Website: <http://www.ultratech-labs.com>

File #: MIC23-FTX
September 5, 2000

- Assessed by ITI (UK) Competent Body, NVLAP (USA) Accreditation Body & ACA/AUSTEL (Australia)
- Recognized/Listed by FCC (USA), Industry Canada (Canada)
- *All test results contained in this engineering test report are traceable to National Institute of Standards and Technology (NIST)*

EXHIBIT 17. BLOCK DIAGRAM

ULTRATECH GROUP OF LABS

3000 Bristol Circle, Oakville, Ontario, Canada L6H 6G4

Tel. #: 905-829-1570, Fax. #: 905-829-8050, Email: vhk.ultratech@sympatico.ca, Website: <http://www.ultratech-labs.com>

File #: MIC23-FTX
September 5, 2000

- Assessed by ITI (UK) Competent Body, NVLAP (USA) Accreditation Body & ACA/AUSTEL (Australia)
- Recognized/Listed by FCC (USA), Industry Canada (Canada)
- *All test results contained in this engineering test report are traceable to National Institute of Standards and Technology (NIST)*

EXHIBIT 18. SCHEMATIC DIAGRAMS

ULTRATECH GROUP OF LABS

3000 Bristol Circle, Oakville, Ontario, Canada L6H 6G4
Tel. #: 905-829-1570, Fax. #: 905-829-8050, Email: vhk.ultratech@sympatico.ca, Website: <http://www.ultratech-labs.com>

File #: MIC23-FTX
September 5, 2000

- Assessed by ITI (UK) Competent Body, NVLAP (USA) Accreditation Body & ACA/AUSTEL (Australia)
- Recognized/Listed by FCC (USA), Industry Canada (Canada)
- *All test results contained in this engineering test report are traceable to National Institute of Standards and Technology (NIST)*

EXHIBIT 19. PARTS LIST/TUNE UP INFO

None.

ULTRATECH GROUP OF LABS

3000 Bristol Circle, Oakville, Ontario, Canada L6H 6G4
Tel. #: 905-829-1570, Fax. #: 905-829-8050, Email: vhk.ultratech@sympatico.ca, Website: <http://www.ultratech-labs.com>

File #: MIC23-FTX
September 5, 2000

- Assessed by ITI (UK) Competent Body, NVLAP (USA) Accreditation Body & ACA/AUSTEL (Australia)
- Recognized/Listed by FCC (USA), Industry Canada (Canada)
- *All test results contained in this engineering test report are traceable to National Institute of Standards and Technology (NIST)*

EXHIBIT 20. OPERATIONAL DESCRIPTION

ULTRATECH GROUP OF LABS

3000 Bristol Circle, Oakville, Ontario, Canada L6H 6G4
Tel. #: 905-829-1570, Fax. #: 905-829-8050, Email: vhk.ultratech@sympatico.ca, Website: <http://www.ultratech-labs.com>

File #: MIC23-FTX
September 5, 2000

- Assessed by ITI (UK) Competent Body, NVLAP (USA) Accreditation Body & ACA/AUSTEL (Australia)
- Recognized/Listed by FCC (USA), Industry Canada (Canada)
- *All test results contained in this engineering test report are traceable to National Institute of Standards and Technology (NIST)*

EXHIBIT 21. RF EXPOSURE INFO

Refer to user's manual.

ULTRATECH GROUP OF LABS

3000 Bristol Circle, Oakville, Ontario, Canada L6H 6G4
Tel. #: 905-829-1570, Fax. #: 905-829-8050, Email: vhk.ultratech@sympatico.ca, Website: <http://www.ultratech-labs.com>

File #: MIC23-FTX
September 5, 2000

- Assessed by ITI (UK) Competent Body, NVLAP (USA) Accreditation Body & ACA/AUSTEL (Australia)
- Recognized/Listed by FCC (USA), Industry Canada (Canada)
- *All test results contained in this engineering test report are traceable to National Institute of Standards and Technology (NIST)*

EXHIBIT 22. USER'S MANUAL

ULTRATECH GROUP OF LABS

3000 Bristol Circle, Oakville, Ontario, Canada L6H 6G4
Tel. #: 905-829-1570, Fax. #: 905-829-8050, Email: vhk.ultratech@sympatico.ca, Website: <http://www.ultratech-labs.com>

File #: MIC23-FTX
September 5, 2000

- Assessed by ITI (UK) Competent Body, NVLAP (USA) Accreditation Body & ACA/AUSTEL (Australia)
- Recognized/Listed by FCC (USA), Industry Canada (Canada)
- *All test results contained in this engineering test report are traceable to National Institute of Standards and Technology (NIST)*