

ENGINEERING TEST REPORT

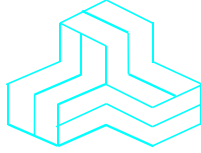

INET
Model No.: INET900

FCC ID: E5M-INET900

Applicant:

Microwave Data Systems Inc.
175 Science Parkway
Rochester, NY
USA, 14620

In Accordance With

FEDERAL COMMUNICATIONS COMMISSION (FCC)
PART 15, SUBPART C, SECTION 15.247
Frequency Hopping Spread Spectrum Transmitters
Operating in the Frequency band 902 - 928 MHz

UltraTech's File No.: MIC46-FTX

This Test report is Issued under the Authority of
Tri M. Luu, Professional Engineer,
Vice President of Engineering
UltraTech Group of Labs



Date: January 24, 2002

Report Prepared by: Dan Huynh

Tested by: Mr. Hung Trinh, EMI/RFI Technician

Issued Date: January 24, 2002

Test Dates: December 16 - 19, 2001

The results in this Test Report apply only to the sample(s) tested, and the sample tested is randomly selected.

UltraTech

3000 Bristol Circle, Oakville, Ontario, Canada, L6H 6G4
Telephone (905) 829-1570 Facsimile (905) 829-8050
Website: www.ultrat4ech-labs.com Email: vhk.ultratech@sympatico.ca

TABLE OF CONTENTS

EXHIBIT 1. SUBMITTAL CHECK LIST.....	1
EXHIBIT 2. INTRODUCTION	2
2.1. SCOPE.....	2
2.2. RELATED SUBMITTAL(S)/GRANT(S).....	2
2.3. NORMATIVE REFERENCES	3
EXHIBIT 3. PERFORMANCE ASSESSMENT	4
3.1. CLIENT INFORMATION	4
3.2. EQUIPMENT UNDER TEST (EUT) INFORMATION.....	4
3.3. EUT'S TECHNICAL SPECIFICATIONS.....	5
3.4. LIST OF EUT'S PORTS	5
3.5. ANCILLARY EQUIPMENT	6
EXHIBIT 4. EUT OPERATING CONDITIONS AND CONFIGURATIONS DURING TESTS.....	7
4.1. CLIMATE TEST CONDITIONS	7
4.2. OPERATIONAL TEST CONDITIONS & ARRANGEMENT FOR TESTS	7
EXHIBIT 5. SUMMARY OF TEST RESULTS	8
5.1. LOCATION OF TESTS	8
5.2. APPLICABILITY & SUMMARY OF EMC EMISSION TEST RESULTS	8
5.3. MODIFICATIONS INCORPORATED IN THE EUT FOR COMPLIANCE PURPOSES	8
EXHIBIT 6. MEASUREMENTS, EXAMINATIONS & TEST DATA FOR EMC EMISSIONS.....	9
6.1. TEST PROCEDURES	9
6.2. MEASUREMENT UNCERTAINTIES	9
6.3. MEASUREMENT EQUIPMENT USED.....	9
6.4. ESSENTIAL/PRIMARY FUNCTIONS AS DECLARED BY THE MANUFACTURER.....	9
6.5. UNLICENSED MODULAR TRANSMITTER APPROVAL REQUIREMENTS @ FCC PUBLIC NOTICE DA 00-1407 (JUNE 26, 2000).....	10
6.6. COMPLIANCE WITH FCC PART 15 – GENERAL TECHNICAL REQUIREMENTS.....	13
6.7. HOPPING CHANNEL CARRIER FREQUENCY CHARACTERISTICS [47 CFR §§ 15.247(A)(1) & (A)(1)(i)].....	17
6.7.1. <i>Limits</i>	17
6.7.2. <i>Method of Measurements</i>	17
6.7.3. <i>Test Arrangement</i>	18
6.7.4. <i>Test Equipment List</i>	18
6.7.5. <i>Test data</i>	19
6.8. PEAK OUTPUT POWER & EQUIVALENT ISOTROPIC RADIATED POWER (EIRP) [47 CFR § 15.247(B)]	20
6.8.1. <i>Limits</i>	20
6.8.2. <i>Method of Measurements</i>	20
6.8.3. <i>Test Arrangement</i>	20
6.8.4. <i>Test Equipment List</i>	20
6.8.5. <i>Test Data</i>	21
6.9. RF EXPOSURE REQUIRMENTS [47 CFR §§ 15.247(B)(4), 1.1310 & 2.1091].....	22
6.9.1. <i>Limits</i>	22

ULTRATECH GROUP OF LABS

3000 Bristol Circle, Oakville, Ontario, Canada L6H 6G4

Tel. #: 905-829-1570, Fax. #: 905-829-8050, Email: vic@ultratech-labs.com , Website: http://www.ultratech-labs.com

File #: MIC46-FTX
January 24, 2002

- Assessed by ITI (UK) Competent Body, NVLAP (USA) Accreditation Body & ACA/AUSTEL (Australia), VCCI (Japan)
- Accredited by Industry Canada (Canada) under ACC-LAB (Europe/Canada MRA and APEC/Canada MRA)
- Recognized/Listed by FCC (USA)
- All test results contained in this engineering test report are traceable to National Institute of Standards and Technology (NIST)

6.9.2.	Method of Measurements.....	22
6.9.3.	Test Data.....	24
6.10.	TRANSMITTER BAND-EDGE & SPURIOUS CONDUCTED EMISSIONS [47 CFR § 15.247(c)].....	25
6.10.1.	Limits.....	25
6.10.2.	Method of Measurements.....	25
6.10.3.	Test Arrangement.....	25
6.10.4.	Test Equipment List.....	25
6.10.5.	Test Data.....	26
6.11.	TRANSMITTER SPURIOUS RADIATED EMISSIONS AT 3 METERS [47 CFR §§ 15.247(c), 15.209 & 15.205].....	27
6.11.1.	Limits.....	27
6.11.2.	Method of Measurements.....	28
6.11.3.	Test Arrangement.....	28
6.11.4.	Test Equipment List.....	29
6.11.5.	Test Data.....	29
EXHIBIT 7.	MEASUREMENT UNCERTAINTY.....	31
7.1.	LINE CONDUCTED EMISSION MEASUREMENT UNCERTAINTY.....	31
7.2.	RADIATED EMISSION MEASUREMENT UNCERTAINTY.....	32
EXHIBIT 8.	MEASUREMENT METHODS.....	33
8.1.	GENERAL TEST CONDITIONS.....	33
8.1.1.	Normal temperature and humidity.....	33
8.1.2.	Normal power source.....	33
8.1.3.	Operating Condition of Equipment under Test.....	33
8.2.	METHOD OF MEASUREMENTS - AC MAINS CONDUCTED EMISSIONS.....	34
8.3.	EQUIVALENT ISOTROPIC RADIATED POWER (EIRP).....	35
8.4.	SPURIOUS EMISSIONS (CONDUCTED & RADIATED).....	38
8.4.1.	Band-Edge and Spurious Emissions (Conducted).....	38
8.4.2.	Spurious Emissions (Radiated).....	39
8.5.	ALTERNATIVE TEST PROCEDURES.....	41
8.5.1.	Peak Power Measurements.....	41
8.5.2.	Spurious RF conducted emissions.....	41

ULTRATECH GROUP OF LABS

3000 Bristol Circle, Oakville, Ontario, Canada L6H 6G4
Tel. #: 905-829-1570, Fax. #: 905-829-8050, Email: vic@ultratech-labs.com, Website: http://www.ultratech-labs.com

File #: MIC46-FTX
January 24, 2002

- Assessed by ITI (UK) Competent Body, NVLAP (USA) Accreditation Body & ACA/AUSTEL (Australia), VCCI (Japan)
- Accredited by Industry Canada (Canada) under ACC-LAB (Europe/Canada MRA and APEC/Canada MRA)
- Recognized/Listed by FCC (USA)
- All test results contained in this engineering test report are traceable to National Institute of Standards and Technology (NIST)

EXHIBIT 1. SUBMITTAL CHECK LIST

Annex No.	Exhibit Type	Description of Contents	Quality Check (OK)
--	Test Report	<ul style="list-style-type: none"> Exhibit 1: Submittal check lists Exhibit 2: Introduction Exhibit 3: Performance Assessment Exhibit 4: EUT Operation and Configuration during Tests Exhibit 5: Summary of test Results Exhibit 6: Measurement Data Exhibit 7: Measurement Uncertainty Exhibit 8: Measurement Methods 	OK
1	Test Report – Test Data Plots	<ul style="list-style-type: none"> 20 dB Bandwidth (Plots # 1 to 6) Channel Hopping Frequency Separation (Plots # 7) Average Time of Occupancy (Plots # 8 to 13) Band-Edge Spurious Emissions at Antenna Terminals (Plots #14 to 21) Spurious Emissions at Antenna Terminals (Plots # 22 to 30) Radiated Emissions (Plots # 31 to 38) 	OK
2	Test Setup Photos	Radiated Emissions Test Setup Photos	OK
3	External Photos of EUT	External EUT Photos	OK
4	Internal Photos of EUT	Internal EUT Photos	OK
5	Cover Letters	<ul style="list-style-type: none"> Letter from Ultratech for Certification Request Letter from the Applicant to appoint Ultratech to act as an agent Letter from the Applicant to request for Confidentiality Filing 	OK
6	Attestation Statements	--	--
7	ID Label/Location Info	<ul style="list-style-type: none"> ID Label Location of ID Label 	OK
8	Block Diagrams	Block Diagram	OK
9	Schematic Diagrams	Schematics	OK
10	Parts List/Tune Up Info	INET Bill of Materials	OK
11	Operational Description	MDS iNet 900 Theory of Operations	OK
12	RF Exposure Info	MPE Evaluation, see section 6.9 in Test Report	OK
13	Users Manual	MDS iNET 900 Wireless IP/Ethernet Transceiver	OK
14	Installation Guide	MDS iNET 900 Wireless IP/Ethernet Transceiver	OK

ULTRATECH GROUP OF LABS

3000 Bristol Circle, Oakville, Ontario, Canada L6H 6G4
 Tel. #: 905-829-1570, Fax. #: 905-829-8050, Email: vic@ultratech-labs.com , Website: http://www.ultratech-labs.com

File #: MIC46-FTX
 January 24, 2002

- Assessed by ITI (UK) Competent Body, NVLAP (USA) Accreditation Body & ACA/AUSTEL (Australia), VCCI (Japan)
- Accredited by Industry Canada (Canada) under ACC-LAB (Europe/Canada MRA and APEC/Canada MRA)
- Recognized/Listed by FCC (USA)
- All test results contained in this engineering test report are traceable to National Institute of Standards and Technology (NIST)

EXHIBIT 2. INTRODUCTION

2.1. SCOPE

Reference:	FCC Part 15, Subpart C, Section 15.247:2000
Title:	Telecommunication – 47 Code of Federal Regulations (CFR), Part 15
Purpose of Test:	To gain FCC Certification Authorization for Frequency Hopping Spread Spectrum Transmitters Operating in the Frequency Band 902 - 928 MHz .
Type of Certification:	<ul style="list-style-type: none">• Modular Transmitter Approval: This application is subject to the FCC certification for Fixed Base Station modular transceiver. This modular transmitter is clarified to comply with the requirements for Modular Approval specified in FCC Public Notice DA 00-1407. • Limitation of the FCC Modular Certification for Model INET900:<ol style="list-style-type: none">1) This modular transmitter is only allowed to be used in Microwave Data Systems Inc. (Marketing to the General Public is Prohibited) with professional installation. Therefore, the unique antenna coupler or permanently attached antenna is exempted2) This modular transmitter is only used for base station with the antenna located outdoor and a separation distance of at least 2 meters is maintained between the transmitter's radiating structure(s) and the body of the user or nearby persons.3) Installers and end-users must be provided with the appropriate information for satisfying RF exposure compliance.
Test Procedures:	Both conducted and radiated emissions measurements were conducted in accordance with American National Standards Institute ANSI C63.4 - American National Standard for Methods of Measurement of Radio-Noise Emissions from Low-Voltage Electrical and Electronic Equipment in the Range of 9 kHz to 40 GHz.
Environmental Classification:	[<input type="checkbox"/>] Residential [<input checked="" type="checkbox"/>] Light-industry, Commercial [<input checked="" type="checkbox"/>] Industry

2.2. RELATED SUBMITTAL(S)/GRANT(S)

None

ULTRATECH GROUP OF LABS

3000 Bristol Circle, Oakville, Ontario, Canada L6H 6G4

Tel. #: 905-829-1570, Fax. #: 905-829-8050, Email: vic@ultratech-labs.com, Website: <http://www.ultratech-labs.com>

File #: MIC46-FTX
January 24, 2002

- Assessed by ITI (UK) Competent Body, NVLAP (USA) Accreditation Body & ACA/AUSTEL (Australia), VCCI (Japan)
- Accredited by Industry Canada (Canada) under ACC-LAB (Europe/Canada MRA and APEC/Canada MRA)
- Recognized/Listed by FCC (USA)
- All test results contained in this engineering test report are traceable to National Institute of Standards and Technology (NIST)

2.3. NORMATIVE REFERENCES

Publication	Year	Title
47 CFR Parts 0-19	2000	Code of Federal Regulations – Telecommunication
ANSI C63.4	1992	American National Standard for Methods of Measurement of Radio-Noise Emissions from Low-Voltage Electrical and Electronic Equipment in the Range of 9 kHz to 40 GHz
CISPR 22 & EN 55022	1997 1998	Limits and Methods of Measurements of Radio Disturbance Characteristics of Information Technology Equipment
CISPR 16-1		Specification for Radio Disturbance and Immunity measuring apparatus and methods
FCC Public Notice DA 00-705	2000	Filing and Measurement Guidelines for Frequency Hopping Spread Spectrum Systems
FCC Public Notice DA 00-1407	2000	Part 15 Unlicensed Modular Transmitter Approval

ULTRATECH GROUP OF LABS

3000 Bristol Circle, Oakville, Ontario, Canada L6H 6G4
Tel. #: 905-829-1570, Fax. #: 905-829-8050, Email: vic@ultratech-labs.com, Website: <http://www.ultratech-labs.com>

File #: MIC46-FTX
January 24, 2002

- Assessed by ITI (UK) Competent Body, NVLAP (USA) Accreditation Body & ACA/AUSTEL (Australia), VCCI (Japan)
- Accredited by Industry Canada (Canada) under ACC-LAB (Europe/Canada MRA and APEC/Canada MRA)
- Recognized/Listed by FCC (USA)
- All test results contained in this engineering test report are traceable to National Institute of Standards and Technology (NIST)

EXHIBIT 3. PERFORMANCE ASSESSMENT

3.1. CLIENT INFORMATION

APPLICANT	
Name:	Microwave Data Systems Inc.
Address:	175 Science Parkway Rochester, NY USA, 14620
Contact Person:	Mr. Dennis McCarthy Agency Compliance Engineer Phone #: 585 242-8440 Fax #: 585 241-5590 Email Address: dmccarthy@microwavedata.com

MANUFACTURER	
Name:	Microwave Data Systems Inc.
Address:	175 Science Parkway Rochester, NY USA, 14620
Contact Person:	Mr. Dennis McCarthy Agency Compliance Engineer Phone #: 585 242-8440 Fax #: 585 241-5590 Email Address: dmccarthy@microwavedata.com

3.2. EQUIPMENT UNDER TEST (EUT) INFORMATION

The following information (with the exception of the Date of Receipt) has been supplied by the applicant.

Brand Name:	Microwave Data Systems Inc.
Product Name:	INET
Model Name or Number:	INET900
Serial Number:	Test Sample
Type of Equipment:	Frequency Hopping Spread Spectrum Transmitters
Input Power Supply Type:	External Regulated DC Sources
Primary User Functions of EUT:	Wireless Data Transfer

ULTRATECH GROUP OF LABS

3000 Bristol Circle, Oakville, Ontario, Canada L6H 6G4
Tel. #: 905-829-1570, Fax. #: 905-829-8050, Email: vic@ultratech-labs.com, Website: <http://www.ultratech-labs.com>

File #: MIC46-FTX
January 24, 2002

- Assessed by ITI (UK) Competent Body, NVLAP (USA) Accreditation Body & ACA/AUSTEL (Australia), VCCI (Japan)
- Accredited by Industry Canada (Canada) under ACC-LAB (Europe/Canada MRA and APEC/Canada MRA)
- Recognized/Listed by FCC (USA)
- All test results contained in this engineering test report are traceable to National Institute of Standards and Technology (NIST)

3.3. EUT'S TECHNICAL SPECIFICATIONS

TRANSMITTER	
Equipment Type:	<input type="checkbox"/> Portable <input type="checkbox"/> Mobile <input checked="" type="checkbox"/> Base Station (fixed use)
Intended Operating Environment:	<input type="checkbox"/> Residential <input checked="" type="checkbox"/> Commercial, light industry & heavy industry
Power Supply Requirement:	13.8 Vdc nominal
RF Output Power Rating:	1 Watt
Operating Frequency Range:	902 - 928 MHz
RF Output Impedance:	50 Ohms
Channel Spacing:	316.5 kHz
Duty Cycle:	Continuous
20 dB Bandwidth:	333
Modulation Type:	CPFSK
Channel Occupancy:	260 mili-seconds within 10 second period
Emission Designation:	Frequency Hopping Spread Spectrum
Oscillator Frequency(ies):	TCXO 16MHz, L.O. – 110.7MHz, 2 nd L.O. 100MHz
Antenna Connector Type:	Non-integral, Standard TNC connector (Professional Installation). Please refer to Installation Guide for detailed instruction of antenna installation and RF Exposure Warning.
Antenna Description:	Manufacturer: MDS ClearWave Antenna Type: Yagi P/N: 97-3662A13 Frequency Range: 890 – 960 MHz In/Out Impedance: 50 Ohms Gain: 8.65 dBi

3.4. LIST OF EUT'S PORTS

Port Number	EUT's Port Description	Number of Identical Ports	Connector Type	Cable Type (Shielded/Non-shielded)
1	LAN	1	RJ-45 Ethernet	Non-Shielded
2	COM1	1	DB9 Female	Shielded
3	COM2	1	DB9 Male	Shielded
4	Antenna	1	TNC	Shielded
5	Power	1	2 Pin Inline	Non-Shielded

ULTRATECH GROUP OF LABS

3000 Bristol Circle, Oakville, Ontario, Canada L6H 6G4
 Tel. #: 905-829-1570, Fax. #: 905-829-8050, Email: vic@ultratech-labs.com, Website: http://www.ultratech-labs.com

File #: MIC46-FTX
 January 24, 2002

- Assessed by ITI (UK) Competent Body, NVLAP (USA) Accreditation Body & ACA/AUSTEL (Australia), VCCI (Japan)
- Accredited by Industry Canada (Canada) under ACC-LAB (Europe/Canada MRA and APEC/Canada MRA)
- Recognized/Listed by FCC (USA)
- All test results contained in this engineering test report are traceable to National Institute of Standards and Technology (NIST)

3.5. ANCILLARY EQUIPMENT

The EUT was tested while connected to the following representative configuration of ancillary equipment necessary to exercise the ports during tests:

Ancillary Equipment # 1	
Description:	Laptop
Brand:	Toshiba
Model Name or Number:	1605CDS/4.3
Serial Number:	1027387CU
Connected to EUT's Port:	COM1

ULTRATECH GROUP OF LABS

3000 Bristol Circle, Oakville, Ontario, Canada L6H 6G4

Tel. #: 905-829-1570, Fax. #: 905-829-8050, Email: vic@ultratech-labs.com, Website: <http://www.ultratech-labs.com>

File #: MIC46-FTX
January 24, 2002

- Assessed by ITI (UK) Competent Body, NVLAP (USA) Accreditation Body & ACA/AUSTEL (Australia), VCCI (Japan)
- Accredited by Industry Canada (Canada) under ACC-LAB (Europe/Canada MRA and APEC/Canada MRA)
- Recognized/Listed by FCC (USA)
- All test results contained in this engineering test report are traceable to National Institute of Standards and Technology (NIST)

EXHIBIT 4. EUT OPERATING CONDITIONS AND CONFIGURATIONS DURING TESTS

4.1. CLIMATE TEST CONDITIONS

The climate conditions of the test environment are as follows:

Temperature:	21°C
Humidity:	51%
Pressure:	102 kPa
Power Input Source:	13.8 Vdc nominal

4.2. OPERATIONAL TEST CONDITIONS & ARRANGEMENT FOR TESTS

Operating Modes:	<ul style="list-style-type: none"> ▪ Each of lowest, middle and highest channel frequencies transmits continuously for emissions measurements. ▪ The EUT operates in normal Frequency Hopping mode for occupancy duration, and frequency separation.
Special Test Software & Hardware:	Special firmware and hardware provided by the Applicant are installed to allow the EUT to operate in hopping mode or at each channel frequency continuously. For example, the transmitter will be operated at each of lowest, middle and highest frequencies individually continuously during testing.
Transmitter Test Antenna:	The EUT is tested with the antenna fitted in a manner typical of normal intended use as non-integral antenna equipment.

Transmitter Test Signals	
Frequency Band(s):	902 - 928 MHz
Frequency(ies) Tested:	Lowest: 902.5000 MHz Middle: 915.1600 MHz Highest: 927.5035 MHz
RF Power Output (measured maximum output power):	30 dBm, 1Watt
Normal Test Modulation:	CPFSK
Modulating Signal Source:	Internal

ULTRATECH GROUP OF LABS

3000 Bristol Circle, Oakville, Ontario, Canada L6H 6G4
 Tel. #: 905-829-1570, Fax. #: 905-829-8050, Email: vic@ultratech-labs.com, Website: http://www.ultratech-labs.com

File #: MIC46-FTX
 January 24, 2002

- Assessed by ITI (UK) Competent Body, NVLAP (USA) Accreditation Body & ACA/AUSTEL (Australia), VCCI (Japan)
- Accredited by Industry Canada (Canada) under ACC-LAB (Europe/Canada MRA and APEC/Canada MRA)
- Recognized/Listed by FCC (USA)
- All test results contained in this engineering test report are traceable to National Institute of Standards and Technology (NIST)

EXHIBIT 5. SUMMARY OF TEST RESULTS

5.1. LOCATION OF TESTS

All of the measurements described in this report were performed at Ultratech Group of Labs located in the city of Oakville, Province of Ontario, Canada.

- AC Powerline Conducted Emissions were performed in UltraTech's shielded room, 16'(L) by 12'(W) by 12'(H).
- Radiated Emissions were performed at the Ultratech's 3 Meter Open Field Test Site (OFTS) situated in the Town of Oakville, province of Ontario.

The above sites have been calibrated in accordance with ANSI C63.4, and found to be in compliance with the requirements of Sec. 2.948 of the FCC Rules. The descriptions and site measurement data of the Oakville Open Field Test Site has been filed with FCC office (FCC File No.: 31040/SIT 1300B3) and Industry Canada office (Industry Canada File No.: IC2049). Last Date of Site Calibration: August 8, 2001.

5.2. APPLICABILITY & SUMMARY OF EMC EMISSION TEST RESULTS

FCC Paragraph	Test Requirements	Compliance (Yes/No)
Public Notice DA 00-1407	Part 15 Unlicensed Modular Transmitter Approval	Yes
15.107(a)	AC Power Line Conducted Emissions Measurements (Transmit & Receive)	N/A
15.247(a)(1) & 15.247(a)(1)(i)	Frequency Hopping Systems Characteristics	Yes
15.247(b)(2)	Peak Output Power	Yes
15.247(b)(4), 1.1307, 1.1310, 2.1091 & 2.1093	RF Exposure Limit	Yes
15.247(c)	Band-Edge and RF Conducted Spurious Emissions at the Transmitter Antenna Terminal	Yes
15.247(c), 15.209 & 15.205	Transmitter Radiated Emissions	Yes
The digital circuit portion of the EUT has been tested and verified to comply with FCC Part 15, Subpart B, Class A Digital Devices and the associated Radio Receiver operating in 902 - 928 MHz has also been tested and found to comply with FCC Part 15, Subpart B – Radio Receivers. The engineering test report can be provided upon FCC requests.		

5.3. MODIFICATIONS INCORPORATED IN THE EUT FOR COMPLIANCE PURPOSES

None

- Assessed by ITI (UK) Competent Body, NVLAP (USA) Accreditation Body & ACA/AUSTEL (Australia), VCCI (Japan)
- Accredited by Industry Canada (Canada) under ACC-LAB (Europe/Canada MRA and APEC/Canada MRA)
- Recognized/Listed by FCC (USA)
- All test results contained in this engineering test report are traceable to National Institute of Standards and Technology (NIST)

EXHIBIT 6. MEASUREMENTS, EXAMINATIONS & TEST DATA FOR EMC EMISSIONS

6.1. TEST PROCEDURES

This section contains test results only. Details of test methods and procedures can be found in Exhibit 8 of this report, ANSI C63-4:1992 and FCC Public Notice @ DA 00-705 (March 30, 2000) – Filing and Measurement Guidelines for Frequency Hopping Spread Spectrum Systems.

6.2. MEASUREMENT UNCERTAINTIES

The measurement uncertainties stated were calculated in accordance with requirements of UKAS Document NIS 81 with a confidence level of 95%. Please refer to Exhibit 7 for Measurement Uncertainties.

6.3. MEASUREMENT EQUIPMENT USED

The measurement equipment used complied with the requirements of the Standards referenced in the Methods & Procedures ANSI C64-3:1992, FCC 15.247 and CISPR 16-1.

6.4. ESSENTIAL/PRIMARY FUNCTIONS AS DECLARED BY THE MANUFACTURER

The essential function of the EUT is to correctly communicate data to and from radios over RF link.

ULTRATECH GROUP OF LABS

3000 Bristol Circle, Oakville, Ontario, Canada L6H 6G4

Tel. #: 905-829-1570, Fax. #: 905-829-8050, Email: vic@ultratech-labs.com, Website: <http://www.ultratech-labs.com>

File #: MIC46-FTX
January 24, 2002

- Assessed by ITI (UK) Competent Body, NVLAP (USA) Accreditation Body & ACA/AUSTEL (Australia), VCCI (Japan)
- Accredited by Industry Canada (Canada) under ACC-LAB (Europe/Canada MRA and APEC/Canada MRA)
- Recognized/Listed by FCC (USA)
- All test results contained in this engineering test report are traceable to National Institute of Standards and Technology (NIST)

6.5. UNLICENSED MODULAR TRANSMITTER APPROVAL REQUIREMENTS @ FCC PUBLIC NOTICE DA 00-1407 (JUNE 26, 2000)

In order to satisfy FCC requirements for equipment authorization for modular transmitters, the transmitters shall meet the following parameters:

Requirements for Modular Transmitters	Manufacturer's Clarification	Laboratory's Comments
(a) In order to be considered a transmitter module, the device must be complete RF transmitter, i.e., it must have its own reference oscillator (e.g., VCO), antenna, etc.... The only connectors to the module, if any, may be power supply and modulation/data inputs	✓ The transmitter is completed with its own reference oscillator and antenna.	Conform
	✓ Only connectors provide are dc supply, data and rf ports are provided with the modular transmitter	Conform
(b) Compliance with FCC RF Exposure requirements may, in some instances, limit the output power of a module and/or the final applications in which the approved module may be employed	✓ The radio is intended for use with fixed base stations only. It complies with MPE per 2.1091 & 1.1307	Conform
(c) While the applicant for a device into which an authorized module is installed is not required to obtain a new authorization for the module, this does not preclude the possibility that some other form of authorization or testing may be required for the device (e.g., a WLAN into which the authorized module is installed still be authorized as PC peripheral, subject to the appropriate equipment authorization)	✓ The equipment under test complies with FCC Part15, Subpart B, Class A – Unintentional radiators	Conform
(d) In the case of a modular transceiver, the modular approval policy only applies to the transmitter portion of such devices. Pursuant to section 15.101(b), the receiver portion will either be subject to Verification, or it will not be subject to any authorization requirements (unless it is a Scanning Receiver, in which case it is also subject to Certification, pursuant to Section 15.101(a)	✓ The receiver complies with FCC Part 15, Subpart B – Radio Receivers.	Conform
(e) The holder of the grant of equipment authorization (Grantee) of the module is responsible for the compliance of the module in its final configuration, provided that the OEM, integrator, and /or end user has complied with all of the instructions provided by the Grantee which indicate installation and/or operating conditions necessary for compliance.	End-users must comply with the following instruction stated in the users' manual:	
	✓ Labeling requirement for equipment using this modular transmitter. ✓ RF Exposure Warning for compliance with FCC Rules 2.1091 and 1.1307 when the radio is used in base system	Conform. Conform.

ULTRATECH GROUP OF LABS

3000 Bristol Circle, Oakville, Ontario, Canada L6H 6G4
 Tel. #: 905-829-1570, Fax. #: 905-829-8050, Email: vic@ultratech-labs.com, Website: http://www.ultratech-labs.com

File #: MIC46-FTX
 January 24, 2002

- Assessed by ITI (UK) Competent Body, NVLAP (USA) Accreditation Body & ACA/AUSTEL (Australia), VCCI (Japan)
- Accredited by Industry Canada (Canada) under ACC-LAB (Europe/Canada MRA and APEC/Canada MRA)
- Recognized/Listed by FCC (USA)
- All test results contained in this engineering test report are traceable to National Institute of Standards and Technology (NIST)

In order to obtain a modular transmitter approval, a cover letter requesting modular approval must be submitted and the numbered requirements identified below must be addressed in the application for equipment authorization:

Requirements for Modular Transmitters	Manufacturer's Clarification	Laboratory's Comments
1. The modulator transmitter must have its own RF shielding. This is intended to ensure that the module does not have to rely upon the shielding provided by the device into which it is installed in order for all modular transmitter emissions to comply with Part 15 limits. It is also intended to prevent coupling between the RF circuitry of the module and any wires or circuits in the device into which the module is installed. Such coupling may result in non-complaint operation.	The RF portion of the board is fully shielded.	Left for FCC Comments
2. The modular transmitter must have buffered modulation/data inputs (if such inputs are provided) to ensure that the module will comply with Part 15 requirements under conditions of excessive data rates or over-modulation.	Data buffering is provided via the on-board microprocessor. Data in excess of the channel capacity is buffered or refused to insure the limits of the channel.	Conform
3. The modular transmitter must have its own power supply regulation. This is intended to ensure that the module will comply with Part 15 requirements regardless of the design of the power supplying circuitry in the device into which the module is installed.	A switching regulator converts a 10v-30v DC input into a regulated internal 3.3v supply.	Conform
4. The modular transmitter must comply with the antenna requirements of section 15.203 and 15.204(c). The antenna must either be permanently attached or employ a "unique" antenna coupler (at all connections between the module and the antenna, including the cable). Any antenna used with the module must be approved with the module, either at the time of initial authorization or through a Class II permissive change. The "professional installation" provision of Section 15.203 may not be applied to modules.	MDS is applying for <i>Limited Modular Approval (LMA)</i> as defined in DA 00-1407. The module will be installed into enclosures designed and manufactured by MDS, hence assuring compliance of the end product. Therefore, MDS would like to apply for the waiver of permanently attached or unique antenna coupler. The antenna will be professionally installed for any OEM product.	Left for FCC Comments

ULTRATECH GROUP OF LABS

3000 Bristol Circle, Oakville, Ontario, Canada L6H 6G4
 Tel. #: 905-829-1570, Fax. #: 905-829-8050, Email: vic@ultratech-labs.com, Website: http://www.ultratech-labs.com

File #: MIC46-FTX
 January 24, 2002

- Assessed by ITI (UK) Competent Body, NVLAP (USA) Accreditation Body & ACA/AUSTEL (Australia), VCCI (Japan)
- Accredited by Industry Canada (Canada) under ACC-LAB (Europe/Canada MRA and APEC/Canada MRA)
- Recognized/Listed by FCC (USA)
- All test results contained in this engineering test report are traceable to National Institute of Standards and Technology (NIST)

Requirements for Modular Transmitters	Manufacturer's Clarification	Laboratory's Comments
<p>5. The modular transmitter must be tested in a stand-alone configuration, i.e., the module must not be inside another device during testing. This is intended to demonstrate that the module is capable of complying with Part 15 emission limits regardless of the device into which it is eventually installed. Unless the transmitter module will be battery powered, it must comply with the AC conducted requirements found in Section 15.207. AC or DC power lines and data input/output lines connected to the module must not contain ferrites, unless they will marketed with the module (see Section 15.27(a)). The length of these lines shall be length typical of actual use or, if that length is unknown, at least 10 centimeters to insure that there is no coupling between the case of the module and supporting equipment. Any accessories, peripherals, or support equipment connected to the module during testing shall be unmodified or commercially available (See Section 15.31(I)).</p>	<p>✓ The modular transmitter was tested in a stand-alone configuration</p>	<p>Conform</p>

ULTRATECH GROUP OF LABS

3000 Bristol Circle, Oakville, Ontario, Canada L6H 6G4
 Tel. #: 905-829-1570, Fax. #: 905-829-8050, Email: vic@ultratech-labs.com, Website: http://www.ultratech-labs.com

File #: MIC46-FTX
 January 24, 2002

- Assessed by ITI (UK) Competent Body, NVLAP (USA) Accreditation Body & ACA/AUSTEL (Australia), VCCI (Japan)
- Accredited by Industry Canada (Canada) under ACC-LAB (Europe/Canada MRA and APEC/Canada MRA)
- Recognized/Listed by FCC (USA)
- All test results contained in this engineering test report are traceable to National Institute of Standards and Technology (NIST)

6.6. COMPLIANCE WITH FCC PART 15 – GENERAL TECHNICAL REQUIREMENTS

FCC Section	FCC Rules	Manufacturer's Clarification
15.31	The hopping function must be disabled for tests, which should be performed with the EUT transmitting on the number of frequencies specified in this Section. The measurements made at the upper and lower ends of the band of operation should be made with the EUT tuned to the highest and lowest available channels.	Hopping function was disabled during testing
15.203	<p>Described how the EUT complies with the requirement that either its antenna is permanently attached, or that it employs a unique antenna connector, for every antenna proposed for use with the EUT.</p> <p>The exception is in those cases where EUT must be professionally installed. In order to demonstrate that professional installation is required, the following 3 points must be addressed:</p> <ul style="list-style-type: none"> • The application (or intended use) of the EUT • The installation requirements of the EUT • The method by which the EUT will be marketed 	<p>Application descriptions and installation requirements are provided in the product manual. (MDS INET 900 Installation Guide)</p> <p>MDS manufactures products which are sold by MDS's sales department to be used by industrial customers to provide data communication infrastructure, and as such the products are installed by professionals, not by ordinary consumers. Typical installations involve tower construction, antenna installation, feed line fabrication and routing which often is within conduit, radio installation, and power provisioning. Since the length and type of feedline varies widely, professional installation with a standard RF connection is a necessity.</p>
15.204	<p>Provided the information for every antenna proposed for use with the EUT:</p> <p>(a) type (e.g. Yagi, patch, grid, dish, etc...), (b) manufacturer and model number (c) gain with reference to an isotropic radiator</p>	Please refer to section 3.3 of this test report for details of antenna information
15.247(a)	Description of how the EUT meets the definition of a frequency hopping spread spectrum, found in Section 2.1. Based on the technical description.	The radio hops on 316.5 KHz channels using a pseudo-random sequence. It utilizes greater than 50 frequencies and uses each frequency less than 0.4 seconds within any 10 second period.

ULTRATECH GROUP OF LABS

3000 Bristol Circle, Oakville, Ontario, Canada L6H 6G4
 Tel. #: 905-829-1570, Fax. #: 905-829-8050, Email: vic@ultratech-labs.com, Website: http://www.ultratech-labs.com

File #: MIC46-FTX
 January 24, 2002

- Assessed by ITI (UK) Competent Body, NVLAP (USA) Accreditation Body & ACA/AUSTEL (Australia), VCCI (Japan)
- Accredited by Industry Canada (Canada) under ACC-LAB (Europe/Canada MRA and APEC/Canada MRA)
- Recognized/Listed by FCC (USA)
- All test results contained in this engineering test report are traceable to National Institute of Standards and Technology (NIST)

FCC Section	FCC Rules	Manufacturer's Clarification
15.247(a)	<p><u>Pseudo Frequency Hopping Sequence:</u> Describe how the hopping sequence is generated. Provide an example of the hopping sequence channels, in order to demonstrate that the sequence meets the requirements specified in the definition of a frequency hopping spread spectrum system, found in Section 2.1</p>	<p>The pseudo-random sequence is derived from a Linear Congruential Generator (LCG). $\text{rnd}(i+1) = (\text{rnd}(i)*b + a) \text{ mod } 128$ "a" and "b" are chosen based on system address (Network Name) and are qualified to guarantee a sequence of length 80. Skipped channels are removed from the sequence. Mapping of sequence index to frequency is based on $902.5\text{MHz} + \text{index} * 316.5\text{KHz}$, where index is a value between 0 and 79.</p> <p>A sample sequence is provided listed as ATTACHMENT #1.</p>
15.247(a)	<p><u>Equal Hopping Frequency Use:</u> Describe how each individual EUT meets the requirement that each of its hopping channels is used equally on average (e.g. that each new transmission event begins on the next channel in the hopping sequence after final channel used in the previous transmission events).</p>	<p>Average dwell time is controlled by the on-board microprocessor. Hopping is asynchronous to data input. Randomly presented data will be randomly distributed across all channels in the sequence.</p>
15.247(g)	<p>Describe how the EUT complies with the requirement that it be designed to be capable of operating as a true frequency hopping system</p>	<p>The radio will always hop on a minimum of 56 channels. Dwell time is an equal fixed duration on each channel. In the presence of continuous data all channels in the hop sequence will be used equally. This applies to a radio configured as either an Access Point or a remote.</p>
15.247(h)	<p>Describe how the EUT complies with the requirement that it not have the ability to coordinated with other FHSS is an effort to avoid the simultaneous occupancy of individual hopping frequencies by multiple transmitters</p>	<p>Hopping is statically determined based on system address and other configurable parameters. The radio does NOT alter this pattern based on channel occupancy or any other dynamic factors.</p>
Public Notice DA 00-705	<p><u>System Receiver Input Bandwidth:</u> Describe how the associated receiver(s) complies with the requirement that its input bandwidth (either RF or IF) matches the bandwidth of the transmitted signal.</p>	<p>The receiver has an IF bandwidth of 400 KHz, matching the bandwidth of the transmitted signal</p>
Public Notice DA 00-705	<p><u>System Receiver Hopping Capability:</u> Describe how the associated receiver(s) has the ability to shift frequencies in synchronization with the transmitted signals</p>	<p>Once synchronization is achieved, all radios hop in lock step together with the master. Timing adjustments to cover clock drift are made based on the measured arrival time of dedicated Beacon messages.</p>

ULTRATECH GROUP OF LABS

3000 Bristol Circle, Oakville, Ontario, Canada L6H 6G4
 Tel. #: 905-829-1570, Fax. #: 905-829-8050, Email: vic@ultratech-labs.com, Website: http://www.ultratech-labs.com

File #: MIC46-FTX
 January 24, 2002

- Assessed by ITI (UK) Competent Body, NVLAP (USA) Accreditation Body & ACA/AUSTEL (Australia), VCCI (Japan)
- Accredited by Industry Canada (Canada) under ACC-LAB (Europe/Canada MRA and APEC/Canada MRA)
- Recognized/Listed by FCC (USA)
- All test results contained in this engineering test report are traceable to National Institute of Standards and Technology (NIST)

ATTACHMENT #1

Sample Psuedo-Random Sequence (values 0-79)

<u>Index</u>	<u>Channel #</u>	<u>Frequency (Hz)</u>
[00]	28	911367582
[01]	18	908202562
[02]	72	925293667
[03]	62	922128648
[04]	65	923078153
[05]	45	916748115
[06]	32	912633589
[07]	67	923711157
[08]	22	909468570
[09]	25	910418076
[10]	76	926559675
[11]	47	917381118
[12]	66	923394655
[13]	05	904088037
[14]	27	911051080
[15]	36	913899597
[16]	07	904721041
[17]	26	910734578
[18]	70	924660663
[19]	73	925610169
[20]	53	919280130
[21]	40	915165605
[22]	75	926243173
[23]	30	912000585
[24]	33	912950091
[25]	55	919913134
[26]	74	925926671
[27]	13	906620053
[28]	00	902505527
[29]	35	913583095
[30]	44	916431613
[31]	15	907253056
[32]	34	913266593
[33]	78	927192679
[34]	04	903771535
[35]	61	921812146
[36]	48	917697620
[37]	38	914532601
[38]	41	915482107
[39]	63	922445149
[40]	21	909152068
[41]	08	905037543
[42]	43	916115111
[43]	01	902822029

ULTRATECH GROUP OF LABS

3000 Bristol Circle, Oakville, Ontario, Canada L6H 6G4

Tel. #: 905-829-1570, Fax. #: 905-829-8050, Email: vic@ultratech-labs.com, Website: <http://www.ultratech-labs.com>

File #: MIC46-FTX
January 24, 2002

- Assessed by ITI (UK) Competent Body, NVLAP (USA) Accreditation Body & ACA/AUSTEL (Australia), VCCI (Japan)
- Accredited by Industry Canada (Canada) under ACC-LAB (Europe/Canada MRA and APEC/Canada MRA)
- Recognized/Listed by FCC (USA)
- All test results contained in this engineering test report are traceable to National Institute of Standards and Technology (NIST)

[44]	52	918963628
[45]	23	909785072
[46]	42	915798609
[47]	03	903455033
[48]	12	906303551
[49]	02	903138531
[50]	69	924344161
[51]	56	920229636
[52]	46	917064616
[53]	49	918014122
[54]	71	924977165
[55]	29	911684084
[56]	16	907569558
[57]	51	918647126
[58]	06	904404539
[59]	09	905354045
[60]	60	921495644
[61]	31	912317087
[62]	50	918330624
[63]	11	905987049
[64]	20	908835566
[65]	10	905670547
[66]	77	926876177
[67]	64	922761651
[68]	54	919596632
[69]	57	920546138
[70]	79	927509180
[71]	37	914216099
[72]	24	910101574
[73]	59	921179142
[74]	14	906936554
[75]	17	907886060
[76]	68	924027659
[77]	39	914849103
[78]	58	920862640
[79]	19	908519064

ULTRATECH GROUP OF LABS

3000 Bristol Circle, Oakville, Ontario, Canada L6H 6G4

Tel. #: 905-829-1570, Fax. #: 905-829-8050, Email: vic@ultratech-labs.com, Website: <http://www.ultratech-labs.com>

File #: MIC46-FTX

January 24, 2002

- Assessed by ITI (UK) Competent Body, NVLAP (USA) Accreditation Body & ACA/AUSTEL (Australia), VCCI (Japan)
- Accredited by Industry Canada (Canada) under ACC-LAB (Europe/Canada MRA and APEC/Canada MRA)
- Recognized/Listed by FCC (USA)
- All test results contained in this engineering test report are traceable to National Institute of Standards and Technology (NIST)

6.7. HOPPING CHANNEL CARRIER FREQUENCY CHARACTERISTICS [47 CFR §§ 15.247(a)(1) & (a)(1)(i)]

6.7.1. Limits

- **FCC 47 CFR, Para 15.247(a)(1):** Frequency hopping systems shall have hopping channel carrier frequencies separated by a minimum of 25 kHz or the 20 dB bandwidth of the hopping channel, whichever is greater. The system shall hop to channel frequencies that are selected at the system hopping rate from a pseudorandomly ordered list of hopping frequencies. Each frequency must be used equally on the average by each transmitter. The system receivers shall have input bandwidths that match the hopping channel bandwidths of their corresponding transmitters and shall shift frequencies in synchronization with the transmitted signals.
- **FCC 47 CFR, Para 15.247(a)(1)(i):** For frequency hopping systems operating in the 902–928 MHz band: if the 20 dB bandwidth of the hopping channel is less than 250 kHz, the system shall use at least 50 hopping frequencies and the average time of occupancy on any frequency shall not be greater than 0.4 seconds within a 20 second period; if the 20 dB bandwidth of the hopping channel is 250 kHz or greater, the system shall use at least 25 hopping frequencies and the average time of occupancy on any frequency shall not be greater than 0.4 seconds within a 10 second period. The maximum allowed 20 dB bandwidth of the hopping channel is 500 kHz.

6.7.2. Method of Measurements

Refer to FCC 15.247(a)(1) & ANSI C63-4:1992 and Public Notice DA 00-705

Carrier Frequency Separation:

The hopping function of the EUT is enabled. Use the spectrum analyzer setting as follows:

- Span = wide enough to capture the peaks of two adjacent channels
- RBW = 1% of the span
- VBW = RBW
- Sweep = Auto
- Detector = peak
- Trace = max hold

Number of hopping frequency:

The hopping function of the EUT is enabled. Use the spectrum analyzer setting as follows:

- Span = the frequency band of operation
- RBW = 1% of the span
- VBW = RBW
- Sweep = Auto
- Detector = peak
- Trace = max hold

ULTRATECH GROUP OF LABS

3000 Bristol Circle, Oakville, Ontario, Canada L6H 6G4

Tel. #: 905-829-1570, Fax. #: 905-829-8050, Email: vic@ultratech-labs.com, Website: <http://www.ultratech-labs.com>

File #: MIC46-FTX
January 24, 2002

- Assessed by ITI (UK) Competent Body, NVLAP (USA) Accreditation Body & ACA/AUSTEL (Australia), VCCI (Japan)
- Accredited by Industry Canada (Canada) under ACC-LAB (Europe/Canada MRA and APEC/Canada MRA)
- Recognized/Listed by FCC (USA)
- All test results contained in this engineering test report are traceable to National Institute of Standards and Technology (NIST)

Time of Occupancy (Dwell Time):

The hopping function of the EUT is enabled. Use the spectrum analyzer setting as follows:

- Span = 0 Hz centered on a hopping channel
- RBW = 1 MHz
- VBW = RBW
- Sweep = as necessary to capture the entire dwell time per hopping channel
- Detector = peak
- Trace = max hold

If possible, use the marker-delta function to determine the dwell time. If this value varies with different modes of operation (e.g. data rate modulation format, etc.), repeat this test for each variation. The limit is specified in one of the subparagraphs of this Section. Submit this plot(s). An oscilloscope may be used instead of a spectrum analyzer.

20 dB Bandwidth:

Use the spectrum analyzer setting as follows:

- Span = approximately 2 to 3 times the 20 dB bandwidth, centered on a hopping channel
- RBW = 1% of the 20 dB bandwidth
- VBW = RBW
- Sweep = auto
- Detector = peak
- Trace = max hold
- The transmitter shall be transmitting at its maximum data rate.
- Allow the trace to stabilize.
- Use the marker-to-peak function to set the marker to the peak of the emission.
- Use the marker-delta function to measure 20 dB down on both sides of the emission.
- The 20 dB BW is the delta reading in frequency between two markers.

6.7.3. Test Arrangement

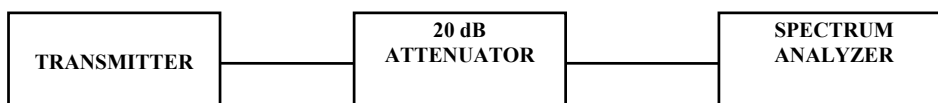

6.7.4. Test Equipment List

Test Instruments	Manufacturer	Model No.	Serial No.	Frequency Range
Spectrum Analyzer/ EMI Receiver	Advantest	R3271	15050203	100 Hz – 26.5 GHz
Attenuator	Weinschel Corp	24-20-34	BJ2357	DC – 8.5 GHz

ULTRATECH GROUP OF LABS

3000 Bristol Circle, Oakville, Ontario, Canada L6H 6G4
 Tel. #: 905-829-1570, Fax. #: 905-829-8050, Email: vic@ultratech-labs.com, Website: http://www.ultratech-labs.com

File #: MIC46-FTX
 January 24, 2002

- Assessed by ITI (UK) Competent Body, NVLAP (USA) Accreditation Body & ACA/AUSTEL (Australia), VCCI (Japan)
- Accredited by Industry Canada (Canada) under ACC-LAB (Europe/Canada MRA and APEC/Canada MRA)
- Recognized/Listed by FCC (USA)
- All test results contained in this engineering test report are traceable to National Institute of Standards and Technology (NIST)

6.7.5. Test data

➤ 20 dB Bandwidth Measurements

Channel Frequency (MHz)	20 dB Bandwidth (kHz)	Limit (kHz)	Pass/Fail
Modulation: 2-lever FSK at 512 kbps			
902.50	333	500	Pass
915.16	331	500	Pass
927.50	330	500	Pass
Modulation: 4-lever FSK at 512 kbps			
902.50	306	500	Pass
915.16	299	500	Pass
927.50	296	500	Pass

* Refer to test data plots # 1 to 6 in Annex 1 for detailed information of measurements

Test Description	FCC Specification	Measured Values	Comments
Channel Hopping Frequency Separation	Minimum of 25 kHz or 20dB BW whichever is greater.	317 kHz	Pass, refer to test data plots # 7 in Annex 1 for measurement data
Number hopping frequencies	At least 25 hopping frequencies	80 channels	Pass
20 dB BW of the hopping channel	500 kHz maximum	333 kHz	Pass
Average Time of Occupancy	Not greater than 0.4 seconds within 10 second period	260 mili-seconds within 10 second period	Pass, refer to test data plots # 8 to 13 in Annex 1 for measurement data

FCC Specification	Manufacturer's Explanation
FCC Requirement @ Section 15.247(a)(1): The system shall hop to channel frequencies that are selected at the system hopping rate from a pseudorandomly ordered list of hopping frequencies. Each frequency must be used equally on the average by each transmitter. The system receivers shall have input bandwidths that match the hopping channel bandwidths of their corresponding transmitters and shall shift frequencies in synchronization with the transmitted signals	Conform. Refer to section 6.6 of this report.
FCC Requirement @ Section 15.247(g): Describe how the EUT complies with the requirement that it be designed to be capable of operating as a true frequency hopping system	Conform. Refer to section 6.6 of this report.
FCC Requirement @ Section 15.247(h): Describe how the EUT complies with the requirement that it does not have the ability to coordinated with other FHSS is an effort to avoid the simultaneous occupancy of individual hopping frequencies by multiple transmitters	Conform. Refer to section 6.6 of this report.

ULTRATECH GROUP OF LABS

3000 Bristol Circle, Oakville, Ontario, Canada L6H 6G4
 Tel. #: 905-829-1570, Fax. #: 905-829-8050, Email: vic@ultratech-labs.com, Website: http://www.ultratech-labs.com

File #: MIC46-FTX
 January 24, 2002

- Assessed by ITI (UK) Competent Body, NVLAP (USA) Accreditation Body & ACA/AUSTEL (Australia), VCCI (Japan)
- Accredited by Industry Canada (Canada) under ACC-LAB (Europe/Canada MRA and APEC/Canada MRA)
- Recognized/Listed by FCC (USA)
- All test results contained in this engineering test report are traceable to National Institute of Standards and Technology (NIST)

6.8. PEAK OUTPUT POWER & EQUIVALENT ISOTROPIC RADIATED POWER (EIRP) [47 CFR § 15.247(b)]

6.8.1. Limits

- **47 CFR 15.247(b)(2):** 1 watt for systems employing at least 50 hopping channels; and, 0.25 watts for systems employing less than 50 hopping channels, but at least 25 hopping channels
- **47 CFR 15.247(b)(3):** If the antennas of directional gain greater than 6 dBi are used, the peak power from the intentional radiator shall be reduced below, as appropriate, by the amount in dB that the directional gain of the antenna exceeds 6 dBi.

6.8.2. Method of Measurements

Refer to Exhibit 8, Section 8.3 of this test report, 47 CFR 15.247(b)(2)&(3), and ANSI C63-4:1992

6.8.3. Test Arrangement

- Conducted Output Power at Antenna Terminals

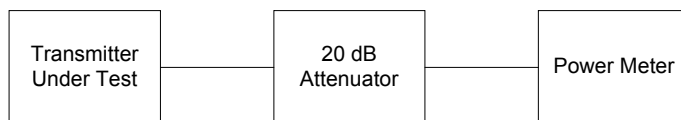

- For EIRP test arrangement, refer to section 8.3 of this test report for details

6.8.4. Test Equipment List

Test Instruments	Manufacturer	Model No.	Serial No.	Frequency Range
Power Meter	Hewlett Packard	436A	1725A02249	10 kHz – 50 GHz, sensor dependent
Power Sensor	Hewlett Packard	8481A	2702A68983	10 MHz – 18 GHz
Attenuator	Weinschel Corp	24-20-34	BJ2357	DC – 8.5 GHz
Spectrum Analyzer/ EMI Receiver	Advantest	R3271	15050203	100 Hz – 26.5 GHz
Dipole Antenna	EMCO	3121C	8907-440	30 MHz – 1 GHz
Dipole Antenna	EMCO	3121C	8907-434	30 MHz – 1 GHz
Synthesized Sweeper	Hewlett Packard	83752B	3610A00457	0.01 – 20 GHz

ULTRATECH GROUP OF LABS

3000 Bristol Circle, Oakville, Ontario, Canada L6H 6G4
 Tel. #: 905-829-1570, Fax. #: 905-829-8050, Email: vic@ultratech-labs.com, Website: http://www.ultratech-labs.com

File #: MIC46-FTX
 January 24, 2002

- Assessed by ITI (UK) Competent Body, NVLAP (USA) Accreditation Body & ACA/AUSTEL (Australia), VCCI (Japan)
- Accredited by Industry Canada (Canada) under ACC-LAB (Europe/Canada MRA and APEC/Canada MRA)
- Recognized/Listed by FCC (USA)
- All test results contained in this engineering test report are traceable to National Institute of Standards and Technology (NIST)

6.8.5. Test Data

6.8.5.1. Peak Power Measurements at Antenna Terminals

For systems employing at least 50 hopping channels:

Transmitter Channel	Frequency (MHz)	Peak Power P at Antenna Terminal (dBm)	Limit (dBm)
Lowest	902.5000	30.0	30.0
Middle	915.1600	30.0	30.0
Highest	927.5035	30.0	30.0

6.8.5.2. EIRP Measurements – Substitution Method

Frequency (MHz)	E-Field E1 in 100 kHz BW @ 3m (dBµV/m)	Antenna Polarization (V/H)	ERP Measured From Signal Generator (dBm)	Substitution Antenna Gain (dBi)	Measured Total EIRP (dBm)	EIRP LIMIT (dBm)
902.5000	133.09	V	32.3	1.8	34.5	36.0
	131.56	H	31.2	1.8	33.4	36.0
915.1600	131.56	V	31.8	2.4	34.0	36.0
	132.41	H	31.8	2.4	33.9	36.0
927.5035	132.38	V	32.4	2.8	34.6	36.0
	131.56	H	32.2	2.8	34.4	36.0

Note: Pasternack Enterprises RG214/U antenna cable was used to connect the MDS ClearWave Yagi Antenna. P/N: 97-3662A13 to the EUT for testing (minimum cable length of 3.13 Metres or 123 Inches).

ULTRATECH GROUP OF LABS

3000 Bristol Circle, Oakville, Ontario, Canada L6H 6G4
 Tel. #: 905-829-1570, Fax. #: 905-829-8050, Email: vic@ultratech-labs.com, Website: http://www.ultratech-labs.com

File #: MIC46-FTX
 January 24, 2002

- Assessed by ITI (UK) Competent Body, NVLAP (USA) Accreditation Body & ACA/AUSTEL (Australia), VCCI (Japan)
- Accredited by Industry Canada (Canada) under ACC-LAB (Europe/Canada MRA and APEC/Canada MRA)
- Recognized/Listed by FCC (USA)
- All test results contained in this engineering test report are traceable to National Institute of Standards and Technology (NIST)

6.9. RF EXPOSURE REQUIRMENTS [47 CFR §§ 15.247(b)(4), 1.1310 & 2.1091]

6.9.1. Limits

- **FCC 15.247(b)(4):** Systems operating under provisions of this section shall be operated in a manner that ensures that the public is not exposed to radio frequency energy levels in excess of the Commission’s guidelines. See @ 1.1307(b)(1).
- **FCC 1.1310:-** The criteria listed in the following table shall be used to evaluate the environmental impact of human exposure to radio-frequency (RF) radiation as specified in 1.1307(b).

TABLE 1—LIMITS FOR MAXIMUM PERMISSIBLE EXPOSURE (MPE)

Frequency range (MHz)	Electric field strength (V/m)	Magnetic field strength (A/m)	Power density (mW/cm ²)	Averaging time (minutes)
(A) Limits for Occupational/Controlled Exposures				
0.3–3.0	614	1.63	*(100)	6
3.0–30	1842/f	4.89/f	*(900/f ²)	6
30–300	61.4	0.163	1.0	6
300–1500	f/300	6
1500–100,000	5	6
(B) Limits for General Population/Uncontrolled Exposure				
0.3–1.34	614	1.63	*(100)	30
1.34–30	824/f	2.19/f	*(180/f ²)	30
30–300	27.5	0.073	0.2	30
300–1500	f/1500	30
1500–100,000	1.0	30

f = frequency in MHz

* = Plane-wave equivalent power density

NOTE 1 TO TABLE 1: Occupational/controlled limits apply in situations in which persons are exposed as a consequence of their employment provided those persons are fully aware of the potential for exposure and can exercise control over their exposure. Limits for occupational/controlled exposure also apply in situations when an individual is transient through a location where occupational/controlled limits apply provided he or she is made aware of the potential for exposure.

NOTE 2 TO TABLE 1: General population/uncontrolled exposures apply in situations in which the general public may be exposed, or in which persons that are exposed as a consequence of their employment may not be fully aware of the potential for exposure or can not exercise control over their exposure.

6.9.2. Method of Measurements

Refer to FCC @ 1.1310, 2.1091 and Public Notice DA 00-705 (March 30, 2000)

- Spread spectrum transmitters operating under section 15.247 are categorically from routine environmental evaluation to demonstrating RF exposure compliance with respect to MPE and/or SAR limits. These devices are not exempted from compliance (As indicated in Section 15.247(b)(4), these transmitters are required to operate in a manner that ensures that exposure to public users and nearby persons) does not exceed the Commission’s RF exposure guidelines (see Section 1.1307 and 2.1093). Unless a device operates at substantially low power levels, with a low gain antenna(s), supporting information is generally needed to establish the various potential operating configurations and exposure conditions of a transmitter and its antenna(s) in order to determine compliance with the RF exposure guidelines.
- In order to demonstrate compliance with MPE requirements (see Section 2.1091), the following information is typically needed:
 - (1) Calculation that estimates the minimum separation distance (20 cm or more) between an antenna and persons required to satisfy power density limits defined for free space.
 - (2) Antenna installation and device operating instructions for installers (professional/unskilled users), and the parties responsible for ensuring compliance with the RF exposure requirement
 - (3) Any caution statements and/or warning labels that are necessary in order to comply with the exposure limits
 - (4) Any other RF exposure related issues that may affect MPE compliance

ULTRATECH GROUP OF LABS

3000 Bristol Circle, Oakville, Ontario, Canada L6H 6G4

Tel. #: 905-829-1570, Fax. #: 905-829-8050, Email: vic@ultratech-labs.com, Website: http://www.ultratech-labs.com

File #: MIC46-FTX
 January 24, 2002

- Assessed by ITI (UK) Competent Body, NVLAP (USA) Accreditation Body & ACA/AUSTEL (Australia), VCCI (Japan)
- Accredited by Industry Canada (Canada) under ACC-LAB (Europe/Canada MRA and APEC/Canada MRA)
- Recognized/Listed by FCC (USA)
- All test results contained in this engineering test report are traceable to National Institute of Standards and Technology (NIST)

Calculation Method of RF Safety Distance:

$$S = PG/4\pi r^2 = EIRP/4\pi r^2$$

Where: P: power input to the antenna in mW
EIRP: Equivalent (effective) isotropic radiated power
S: power density mW/cm²
G: numeric gain of antenna relative to isotropic radiator
r: distance to centre of radiation in cm

$$r = \sqrt{EIRP/4\pi S}$$

FCC radio frequency exposure limits may not be exceeded at distances closer than r cm from the antenna of this device

- For portable transmitters (see Section 2.1093), or devices designed to operate next to a person's body, compliance is determined with respect to the SAR limit (define in the body tissues) for near-field exposure conditions. If the maximum average output power, operating condition configurations and exposure conditions are comparable to those of existing cellular and PCS phones., an SAR evaluation may be required in order to determine if such a device complies with SAR limit. When SAR evaluation data is not available, and the additional supporting information cannot assure compliance, the Commission may request that an SAR evaluation be performed, as provided for in Section 1.1307(d)

ULTRATECH GROUP OF LABS

3000 Bristol Circle, Oakville, Ontario, Canada L6H 6G4

Tel. #: 905-829-1570, Fax. #: 905-829-8050, Email: vic@ultratech-labs.com, Website: <http://www.ultratech-labs.com>

File #: MIC46-FTX
January 24, 2002

- Assessed by ITI (UK) Competent Body, NVLAP (USA) Accreditation Body & ACA/AUSTEL (Australia), VCCI (Japan)
- Accredited by Industry Canada (Canada) under ACC-LAB (Europe/Canada MRA and APEC/Canada MRA)
- Recognized/Listed by FCC (USA)
- All test results contained in this engineering test report are traceable to National Institute of Standards and Technology (NIST)

6.9.3. Test Data

The minimum separation distance between the antenna and bodies of users are calculated using the following formula:

RF EXPOSURE DISTANCE LIMITS: $r = (PG/4\pi S)^{1/2} = (EIRP/4\pi S)^{1/2}$

$S = 902/1500 \text{ mW/cm}^2$

$EIRP = 34.6 \text{ dBm} = 2884 \text{ mW max.}$

$r = (EIRP/4\pi S)^{1/2} = (2884/4\pi(902/1500))^{1/2} = 20 \text{ cm}$

Therefore, the minimum separation distance from users is 20 cm when used with the antenna specified in this test report.

Evaluation of RF Exposure Compliance Requirements	
RF Exposure Requirements	Compliance with FCC Rules
Minimum calculated separation distance between antenna and persons required: 20 cm	Manufacturer' instruction for separation distance between antenna and persons required: 2 Meters.
Antenna installation and device operating instructions for installers (professional/unskilled users), and the parties responsible for ensuring compliance with the RF exposure requirement	The end product in final installation will be maintained, such that full compliance are always ensured by the manufacturer (Microwave Data Systems Inc.)
Caution statements and/or warning labels that are necessary in order to comply with the exposure limits	Please refer to page iii of the Users Manual for RF Exposure Information
Any other RF exposure related issues that may affect MPE compliance	None.

ULTRATECH GROUP OF LABS

3000 Bristol Circle, Oakville, Ontario, Canada L6H 6G4
 Tel. #: 905-829-1570, Fax. #: 905-829-8050, Email: vic@ultratech-labs.com, Website: http://www.ultratech-labs.com

File #: MIC46-FTX
 January 24, 2002

- Assessed by ITI (UK) Competent Body, NVLAP (USA) Accreditation Body & ACA/AUSTEL (Australia), VCCI (Japan)
- Accredited by Industry Canada (Canada) under ACC-LAB (Europe/Canada MRA and APEC/Canada MRA)
- Recognized/Listed by FCC (USA)
- All test results contained in this engineering test report are traceable to National Institute of Standards and Technology (NIST)

6.10. TRANSMITTER BAND-EDGE & SPURIOUS CONDUCTED EMISSIONS [47 CFR § 15.247(c)]

6.10.1. Limits

In any 100 KHz bandwidth outside the operating frequency band, the radio frequency power that is produced by modulation products of the spreading sequence, the information sequence and the carrier frequency shall be at least 20 dB below that in any 100 KHz bandwidth within the band that contains the highest level of the desired power.

6.10.2. Method of Measurements

Refer to Exhibit 8, Section 8.4 of this test report, 47 CFR § 15.247(c) and ANSI C63-4:1992

6.10.3. Test Arrangement

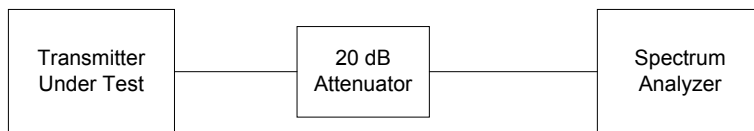

6.10.4. Test Equipment List

Test Instruments	Manufacturer	Model No.	Serial No.	Frequency Range
Spectrum Analyzer/ EMI Receiver	Advantest	R3271	15050203	100 Hz – 26.5 GHz
Attenuator	Weinschel Corp	24-20-34	BJ2357	DC – 8.5 GHz

ULTRATECH GROUP OF LABS

3000 Bristol Circle, Oakville, Ontario, Canada L6H 6G4

Tel. #: 905-829-1570, Fax. #: 905-829-8050, Email: vic@ultratech-labs.com, Website: <http://www.ultratech-labs.com>

File #: MIC46-FTX
January 24, 2002

- Assessed by ITI (UK) Competent Body, NVLAP (USA) Accreditation Body & ACA/AUSTEL (Australia), VCCI (Japan)
- Accredited by Industry Canada (Canada) under ACC-LAB (Europe/Canada MRA and APEC/Canada MRA)
- Recognized/Listed by FCC (USA)
- All test results contained in this engineering test report are traceable to National Institute of Standards and Technology (NIST)

6.10.5. Test Data

6.10.5.1. *Band-Edge Spurious Emissions During Hopping*

Test was performed with the following modulations:

- 1) 2-level CPFSK at 512 kbps data rate
- 2) 4-level CPFSK at 512 kbps data rate

Please refer to test data plots # 14 to 21 in Annex 1 for measurement results.

6.10.5.2. *Lowest Frequency (902.6 MHz)*

The emissions were scanned from 10 MHz to 10 GHz and no emission was found within 20 dB below the limit. Refer to test data plots # 22 to 24 in Annex 1 for measurement results.

6.10.5.3. *Middle Frequency (914.9 MHz)*

The emissions were scanned from 10 MHz to 10 GHz and no emission was found within 20 dB below the limit. Refer to test data plots # 25 to 27 in Annex 1 for measurement results.

6.10.5.4. *Highest Frequency (927.2 MHz)*

The emissions were scanned from 10 MHz to 10 GHz and no emission was found within 20 dB below the limit. Refer to test data plots # 28 to 30 in Annex 1 for measurement results.

ULTRATECH GROUP OF LABS

3000 Bristol Circle, Oakville, Ontario, Canada L6H 6G4

Tel. #: 905-829-1570, Fax. #: 905-829-8050, Email: vic@ultratech-labs.com, Website: <http://www.ultratech-labs.com>

File #: MIC46-FTX
January 24, 2002

- Assessed by ITI (UK) Competent Body, NVLAP (USA) Accreditation Body & ACA/AUSTEL (Australia), VCCI (Japan)
- Accredited by Industry Canada (Canada) under ACC-LAB (Europe/Canada MRA and APEC/Canada MRA)
- Recognized/Listed by FCC (USA)
- All test results contained in this engineering test report are traceable to National Institute of Standards and Technology (NIST)

6.11. TRANSMITTER SPURIOUS RADIATED EMISSIONS AT 3 METERS [47 CFR §§ 15.247(c), 15.209 & 15.205]

6.11.1. Limits

In any 100 KHz bandwidth outside the operating frequency band, the radio frequency power that is produced by modulation products of the spreading sequence, the information sequence and the carrier frequency shall be either at least 20 dB below that in any 100 KHz bandwidth within the band that contains the highest level of the desired power or shall not exceed the general levels specified in section 15.209(a), which lesser attenuation.

All other emissions inside restricted bands specified in section 15.205(a) shall not exceed the general radiated emission limits specified in section 15.209(a)

Remarks:

- Applies to harmonics/spurious emissions that fall in the restricted bands listed in section 15.205. The maximum permitted average field strength is listed in section 15.209.
- **47 CFR § 15.237(c):** The emission limits as specified above are based on measurement instrument employing an average detector. The provisions in section 15.35 for limiting peak emissions apply.

FCC CFR 47, Part 15, Subpart C, Para. 15.205(a) - Restricted Frequency Bands

MHz	MHz	MHz	GHz
0.090-0.110	16.42-16.423	399.9-410	4.5-5.15
¹ 0.495-0.505	16.69475-16.69525	608-614	5.35-5.46
2.1735-2.1905	16.80425-16.80475	960-1240	7.25-7.75
4.125-4.128	25.5-25.67	1300-1427	8.025-8.5
4.17725-4.17775	37.5-38.25	1435-1626.5	9.0-9.2
4.20725-4.20775	73-74.6	1645.5-1646.5	9.3-9.5
6.215-6.218	74.8-75.2	1660-1710	10.6-12.7
6.26775-6.26825	108-121.94	1718.8-1722.2	13.25-13.4
6.31175-6.31225	123-138	2200-2300	14.47-14.5
8.291-8.294	149.9-150.05	2310-2390	15.35-16.2
8.362-8.366	156.52475-156.52525	2483.5-2500	17.7-21.4
8.37625-8.38675	156.7-156.9	2655-2900	22.01-23.12
8.41425-8.41475	162.0125-167.17	3260-3267	23.6-24.0
12.29-12.293	167.72-173.2	3332-3339	31.2-31.8
12.51975-12.52025	240-285	3345.8-3358	36.43-36.5
12.57675-12.57725	322-335.4	3600-4400	(²)
13.36-13.41.			

¹ Until February 1, 1999, this restricted band shall be 0.490-0.510 MHz.

² Above 38.6

47 CFR § 15.209(a)

-- Field Strength Limits within Restricted Frequency Bands --

Frequency (MHz)	Field Strength (microvolts/meter)	Measurement Distance (meters)
0.009 - 0.490	2,400 / F (kHz)	300
0.490 - 1.705	24,000 / F (kHz)	30
1.705 - 30.0	30	30
30 - 88	100	3
88 - 216	150	3
216 - 960	200	3
Above 960	500	3

ULTRATECH GROUP OF LABS

3000 Bristol Circle, Oakville, Ontario, Canada L6H 6G4

Tel. #: 905-829-1570, Fax. #: 905-829-8050, Email: vic@ultratech-labs.com, Website: http://www.ultratech-labs.com

File #: MIC46-FTX

January 24, 2002

- Assessed by ITI (UK) Competent Body, NVLAP (USA) Accreditation Body & ACA/AUSTEL (Australia), VCCI (Japan)
- Accredited by Industry Canada (Canada) under ACC-LAB (Europe/Canada MRA and APEC/Canada MRA)
- Recognized/Listed by FCC (USA)
- All test results contained in this engineering test report are traceable to National Institute of Standards and Technology (NIST)

6.11.2. Method of Measurements

Refer to Exhibit 8, Section 8.4 of this test report and ANSI 63.4-1992, Para. 8 for detailed radiated emissions measurement procedures.

The following measurement procedures were also applied:

- Applies to harmonics/spurious that fall in the restricted bands listed in Section 15.205. the maximum permitted average field strength is listed in Section 15.209. A Pre-Amp and highpass filter are used for this measurement.
- For measurement below 1 GHz, set RBW = 100 KHz, VBW \geq 100 KHz, SWEEP=AUTO.
- For measurement above 1 GHz, set RBW = 1 MHz, VBW = 1 MHz (Peak) & VBW = 10 Hz (Average), SWEEP=AUTO.
- If the emission is pulsed, modified the unit for continuous operation, then use the settings above for measurements, then correct the reading by subtracting the peak-average correction factor derived from the appropriate duty cycle calculation. See Section 15.35(b) and (c).

6.11.3. Test Arrangement

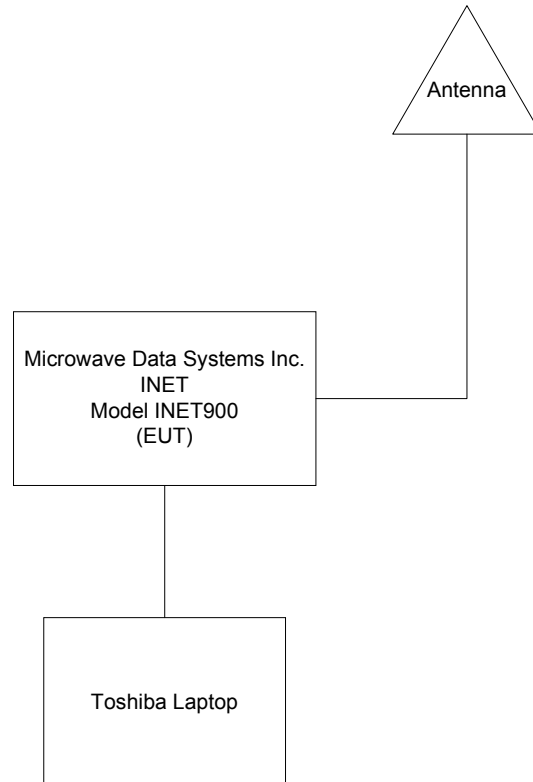

ULTRATECH GROUP OF LABS

3000 Bristol Circle, Oakville, Ontario, Canada L6H 6G4

Tel. #: 905-829-1570, Fax. #: 905-829-8050, Email: vic@ultratech-labs.com, Website: <http://www.ultratech-labs.com>

File #: MIC46-FTX
January 24, 2002

- Assessed by ITI (UK) Competent Body, NVLAP (USA) Accreditation Body & ACA/AUSTEL (Australia), VCCI (Japan)
- Accredited by Industry Canada (Canada) under ACC-LAB (Europe/Canada MRA and APEC/Canada MRA)
- Recognized/Listed by FCC (USA)
- All test results contained in this engineering test report are traceable to National Institute of Standards and Technology (NIST)

6.11.4. Test Equipment List

Test Instruments	Manufacturer	Model No.	Serial No.	Frequency Range
Spectrum Analyzer/ EMI Receiver	Advantest	R3271	15050203	100 Hz – 26.5 GHz
Microwave Amplifier	Hewlett Packard	8449B	3008A00769	1 GHz to 26.5 GHz
Biconilog Antenna	EMCO	3143	1029	20 MHz to 2 GHz
Horn Antenna	EMCO	3155	9701-5061	1 GHz – 18 GHz

6.11.5. Test Data

The following test results are the worst-case measurements:

Lowest Frequency (902.5000 MHz)

Frequency (MHz)	RF Peak Level (dB μ V/m)	RF Avg Level (dB μ V/m)	Antenna Plane (H/V)	Limit 15.209 (dB μ V/m)	Limit 15.247 (dB μ V/m)	Margin (dB)	Pass/Fail
902.5000	133.09	--	V	--	--	--	--
902.5000	131.56	--	H	--	--	--	--
2707.5000	50.84	42.31	V	54.0	113.1	-11.7	*Pass
2707.5000	48.31	37.91	H	54.0	113.1	-16.1	*Pass
3610.0000	57.28	45.22	V	54.0	113.1	-8.8	*Pass
3610.0000	52.66	43.59	H	54.0	113.1	-10.4	*Pass
4512.5000	52.00	41.15	V	54.0	113.1	-12.9	*Pass
4512.5000	50.47	39.22	H	54.0	113.1	-14.8	*Pass
5415.0000	56.78	48.20	V	54.0	113.1	-5.8	*Pass

The emissions were scanned from 10 MHz to 10 GHz and all emissions within 20 dB below the limits were recorded. Refer to test data plots # 31 & 32 in Annex 1 for band-edge emissions.

* Frequency in restricted bands, therefore FCC 15.209 limit applied.

ULTRATECH GROUP OF LABS

3000 Bristol Circle, Oakville, Ontario, Canada L6H 6G4
 Tel. #: 905-829-1570, Fax. #: 905-829-8050, Email: vic@ultratech-labs.com, Website: http://www.ultratech-labs.com

File #: MIC46-FTX
 January 24, 2002

- Assessed by ITI (UK) Competent Body, NVLAP (USA) Accreditation Body & ACA/AUSTEL (Australia), VCCI (Japan)
- Accredited by Industry Canada (Canada) under ACC-LAB (Europe/Canada MRA and APEC/Canada MRA)
- Recognized/Listed by FCC (USA)
- All test results contained in this engineering test report are traceable to National Institute of Standards and Technology (NIST)

Middle Frequency (915.1600 MHz)

Frequency (MHz)	RF Peak Level (dBµV/m)	RF Avg Level (dBµV/m)	Antenna Plane (H/V)	Limit 15.209 (dBµV/m)	Limit 15.247 (dBµV/m)	Margin (dB)	Pass/Fail
915.1600	131.56	--	V	--	--	--	--
915.1600	132.41	--	H	--	--	--	--
2745.4800	48.88	41.41	V	54.0	112.4	-12.6	*Pass
2745.4800	51.47	46.13	H	54.0	112.4	-7.9	*Pass
3660.6400	50.55	41.13	V	54.0	112.4	-12.9	*Pass
3660.6400	48.88	37.97	H	54.0	112.4	-16.0	*Pass
4575.8000	52.13	43.13	V	54.0	112.4	-10.9	*Pass
4575.8000	49.63	38.49	H	54.0	112.4	-15.5	*Pass

The emissions were scanned from 10 MHz to 10 GHz and all emissions within 20 dB below the limits were recorded. Refer to test data plots # 33 & 34 in Annex 1 for band-edge emissions.

* Frequency in restricted bands, therefore FCC 15.209 limit applied.

Highest Frequency (927.5035 MHz)

Frequency (MHz)	RF Peak Level (dBµV/m)	RF Avg Level (dBµV/m)	Antenna Plane (H/V)	Limit 15.209 (dBµV/m)	Limit 15.247 (dBµV/m)	Margin (dB)	Pass/Fail
927.5035	132.38	--	V	--	--	--	--
927.5035	131.56	--	H	--	--	--	--
2782.5105	52.06	46.13	V	54.0	112.4	-7.9	*Pass
2782.5105	48.94	42.47	H	54.0	112.4	-11.5	*Pass
3710.0140	54.13	48.78	V	54.0	112.4	-5.2	*Pass
3710.0140	52.84	47.29	H	54.0	112.4	-6.7	*Pass
4637.5175	52.56	44.40	V	54.0	112.4	-9.6	*Pass
4637.5175	50.19	39.23	H	54.0	112.4	-14.8	*Pass

The emissions were scanned from 10 MHz to 10 GHz and all emissions within 20 dB below the limits were recorded. Refer to test data plots # 35 - 38 in Annex 1 for band-edge emissions.

* Frequency in restricted bands, therefore FCC 15.209 limit applied.

ULTRATECH GROUP OF LABS

3000 Bristol Circle, Oakville, Ontario, Canada L6H 6G4
 Tel. #: 905-829-1570, Fax. #: 905-829-8050, Email: vic@ultratech-labs.com, Website: http://www.ultratech-labs.com

File #: MIC46-FTX
 January 24, 2002

- Assessed by ITI (UK) Competent Body, NVLAP (USA) Accreditation Body & ACA/AUSTEL (Australia), VCCI (Japan)
- Accredited by Industry Canada (Canada) under ACC-LAB (Europe/Canada MRA and APEC/Canada MRA)
- Recognized/Listed by FCC (USA)
- All test results contained in this engineering test report are traceable to National Institute of Standards and Technology (NIST)

EXHIBIT 7. MEASUREMENT UNCERTAINTY

The measurement uncertainties stated were calculated in accordance with the requirements of NIST Technical Note 1297 and NIS 81 (1994)

7.1. LINE CONDUCTED EMISSION MEASUREMENT UNCERTAINTY

CONTRIBUTION (Line Conducted)	PROBABILITY DISTRIBUTION	UNCERTAINTY (dB)	
		9-150 kHz	0.15-30 MHz
EMI Receiver specification	Rectangular	± 1.5	± 1.5
LISN coupling specification	Rectangular	± 1.5	± 1.5
Cable and Input Transient Limiter calibration	Normal (k=2)	± 0.3	± 0.5
Mismatch: Receiver VRC $\Gamma_1 = 0.03$ LISN VRC $\Gamma_R = 0.8$ (9 kHz) 0.2 (30 MHz) Uncertainty limits $20\text{Log}(1 \pm \Gamma_1 \Gamma_R)$	U-Shaped	± 0.2	± 0.3
System repeatability	Std. deviation	± 0.2	± 0.05
Repeatability of EUT	--	--	--
Combined standard uncertainty	Normal	± 1.25	± 1.30
Expanded uncertainty U	Normal (k=2)	± 2.50	± 2.60

Sample Calculation for Measurement Accuracy in 450 kHz to 30 MHz Band:

$$u_c(y) = \sqrt{\sum_{i=1}^m u_i^2(y)} = \pm \sqrt{(1.5^2 + 1.5^2)/3 + (0.5/2)^2 + (0.05/2)^2 + 0.35^2} = \pm 1.30 \text{ dB}$$

$$U = 2u_c(y) = \pm 2.6 \text{ dB}$$

ULTRATECH GROUP OF LABS

3000 Bristol Circle, Oakville, Ontario, Canada L6H 6G4
 Tel. #: 905-829-1570, Fax. #: 905-829-8050, Email: vic@ultratech-labs.com, Website: http://www.ultratech-labs.com

File #: MIC46-FTX
 January 24, 2002

- Assessed by ITI (UK) Competent Body, NVLAP (USA) Accreditation Body & ACA/AUSTEL (Australia), VCCI (Japan)
- Accredited by Industry Canada (Canada) under ACC-LAB (Europe/Canada MRA and APEC/Canada MRA)
- Recognized/Listed by FCC (USA)
- All test results contained in this engineering test report are traceable to National Institute of Standards and Technology (NIST)

7.2. RADIATED EMISSION MEASUREMENT UNCERTAINTY

CONTRIBUTION (Radiated Emissions)	PROBABILITY DISTRIBUTION	UNCERTAINTY (+ dB)	
		3 m	10 m
Antenna Factor Calibration	Normal (k=2)	± 1.0	± 1.0
Cable Loss Calibration	Normal (k=2)	± 0.3	± 0.5
EMI Receiver specification	Rectangular	± 1.5	± 1.5
Antenna Directivity	Rectangular	+0.5	+0.5
Antenna factor variation with height	Rectangular	± 2.0	± 0.5
Antenna phase center variation	Rectangular	0.0	± 0.2
Antenna factor frequency interpolation	Rectangular	± 0.25	± 0.25
Measurement distance variation	Rectangular	± 0.6	± 0.4
Site imperfections	Rectangular	± 2.0	± 2.0
Mismatch: Receiver VRC $\Gamma_1 = 0.2$ Antenna VRC $\Gamma_R = 0.67(Bi) 0.3 (Lp)$ Uncertainty limits $20\text{Log}(1 \pm \Gamma_1 \Gamma_R)$	U-Shaped	+1.1 -1.25	± 0.5
System repeatability	Std. Deviation	± 0.5	± 0.5
Repeatability of EUT		-	-
Combined standard uncertainty	Normal	+2.19 / -2.21	+1.74 / -1.72
Expanded uncertainty U	Normal (k=2)	+4.38 / -4.42	+3.48 / -3.44

Calculation for maximum uncertainty when 3m biconical antenna including a factor of k = 2 is used:

$$U = 2u_c(y) = 2x(+2.19) = +4.38 \text{ dB} \quad \text{And} \quad U = 2u_c(y) = 2x(-2.21) = -4.42 \text{ dB}$$

ULTRATECH GROUP OF LABS

3000 Bristol Circle, Oakville, Ontario, Canada L6H 6G4
 Tel. #: 905-829-1570, Fax. #: 905-829-8050, Email: vic@ultratech-labs.com, Website: http://www.ultratech-labs.com

File #: MIC46-FTX
 January 24, 2002

- Assessed by ITI (UK) Competent Body, NVLAP (USA) Accreditation Body & ACA/AUSTEL (Australia), VCCI (Japan)
- Accredited by Industry Canada (Canada) under ACC-LAB (Europe/Canada MRA and APEC/Canada MRA)
- Recognized/Listed by FCC (USA)
- All test results contained in this engineering test report are traceable to National Institute of Standards and Technology (NIST)

EXHIBIT 8. MEASUREMENT METHODS

8.1. GENERAL TEST CONDITIONS

The following test conditions shall be applied throughout the tests covered in this report.

8.1.1. Normal temperature and humidity

- Normal temperature: +15°C to +35°C
- Relative Humidity: +20% to 75%

The actual values during tests shall be recorded in the test report.

8.1.2. Normal power source

8.1.2.1. Mains Voltage

The nominal test voltage of the equipment to be connected to mains shall be the nominal mains voltage which is the declared voltage or any of the declared voltages for which the equipment was designed.

The frequency of test power source corresponding to the AC mains shall be between 59 Hz and 61 Hz.

8.1.2.2. Battery Power Source.

For operation from battery power sources, the nominal test voltage shall be as declared by the equipment manufacturer. This shall be recorded in the test report.

8.1.3. Operating Condition of Equipment under Test

- All tests were carried out while the equipment operated at the following frequencies:
 - The lowest operating frequency,
 - The middle operating frequency and
 - The highest operating frequency
- Modulation were applied using the Test Data sequence
- The transmitter was operated at the highest output power, or in the case the equipment able to operate at more than one power level, at the lowest and highest output powers

ULTRATECH GROUP OF LABS

3000 Bristol Circle, Oakville, Ontario, Canada L6H 6G4

Tel. #: 905-829-1570, Fax. #: 905-829-8050, Email: vic@ultratech-labs.com, Website: <http://www.ultratech-labs.com>

File #: MIC46-FTX
January 24, 2002

- Assessed by ITI (UK) Competent Body, NVLAP (USA) Accreditation Body & ACA/AUSTEL (Australia), VCCI (Japan)
- Accredited by Industry Canada (Canada) under ACC-LAB (Europe/Canada MRA and APEC/Canada MRA)
- Recognized/Listed by FCC (USA)
- All test results contained in this engineering test report are traceable to National Institute of Standards and Technology (NIST)

8.2. METHOD OF MEASUREMENTS - AC MAINS CONDUCTED EMISSIONS

- AC Mains conducted emissions measurements were performed in accordance with the standard against appropriate limits for each detector function.
- The test was performed in the shielded room, 16'(L) by 16'(W) by 12'(H).
- The test was performed over the frequency range from 450 kHz to 30 MHz to determine the line-to-ground radio noise voltage which was conducted from the EUT power-input terminals that were directly connected to a public power network.
- The EUT normally received power from another device that connects to the public utility ac power lines, measurements would be made on that device with the EUT in operation to ensure that the device continues to comply with the appropriate limits while providing the EUT with power.
- If the EUT operates only from internal or dedicated batteries, with no provisions for connection to the public utility ac power lines, AC Mains conducted measurements are not required.
- Table-top devices were placed on a platform of nominal size 1 m by 1.5m raised 80 cm above the conducting ground plane.
- The EUT current-carrying power lead, except the ground (safety) lead, was individually connected through a LISN to the power source. All unused 50-Ohm connectors of the LISN was terminated in 50-ohm when not connected to the measuring instruments.
- The line cord of the EUT connected to one LISN which was connected to the measuring instrument. Those power cords for the units of devices not under measurement were connected to a separate multiple ac outlet. Drawings and photographs of typically conducted emission test setups were shown in the Test Report. Each current-carrying conductor of the EUT shall be individually tested.
- The EUT was normally operated with a ground (safety) connection, the EUT was connected to the ground at the LISN through a conductor provided in the lead from the ac power mains to the LISN.
- The excess length of the power cord was folded back and forth in an 8-shape on a wooden strip with a vertical prong located on the top of the LISN case.
- The EUT was set-up in its typical configuration and operated in its various modes as described in 3.2 of the test report.
- A preliminary scan was made by using spectrum analyzer system with the detector function set to PEAK mode (9 KHz RBW, VBW > RBW), frequency span 450 kHz to 30 MHz.
- The maximum conducted emission for a given mode of operation was found by using the following step-by-step procedure:
 - Step1. Monitor the frequency range of interest at a fixed EUT azimuth.
 - Step2. Manipulate the system cables and peripheral devices to produce highest amplitude signal relative to the limit. Note the amplitude and frequency of the suspect signal.
 - Step3. The effects of various modes of operation is examined. This is done by varying equipment operation modes as step 2 is being performed.
 - Step4. After completing step 1 through 3, record EUT and peripheral device configuration, mode of operation, cable configuration, signal levels and frequencies for final test.
- Each highest signal level at the maximized test configuration was zoomed in a small frequency span on the spectrum analyzer's display (the manipulation of cables and peripheral devices and EUT operation modes might have to be repeated to obtain the highest signal level with the spectrum analyzer set to PEAK detector mode 10 KHz RBW and VBW > RBW). The spectrum analyzer was then set to CISPR QUASI-PEAK detector mode (9 KHz RBW, 1 MHz VBW) and AVERAGE detector mode (10 kHz RBW, 1 Hz VBW). The final highest RF signal levels and frequencies were record.

ULTRATECH GROUP OF LABS

3000 Bristol Circle, Oakville, Ontario, Canada L6H 6G4

Tel. #: 905-829-1570, Fax. #: 905-829-8050, Email: vic@ultratech-labs.com, Website: <http://www.ultratech-labs.com>

File #: MIC46-FTX
January 24, 2002

- Assessed by ITI (UK) Competent Body, NVLAP (USA) Accreditation Body & ACA/AUSTEL (Australia), VCCI (Japan)
- Accredited by Industry Canada (Canada) under ACC-LAB (Europe/Canada MRA and APEC/Canada MRA)
- Recognized/Listed by FCC (USA)
- All test results contained in this engineering test report are traceable to National Institute of Standards and Technology (NIST)

- **Broad-band ac Powerline conducted emissions:**- If the EUT exhibits ac Powerline conducted emissions that exceed the limit with the instrument set to the quasi-peak mode, then measurements should be made in the average mode. If the amplitude measured in the quasi-peak mode is at least 6 dB higher than the amplitude measured in the average mode, the level measured in quasi peak mode may be reduced by 13 dB before comparing it to the limit.

8.3. EQUIVALENT ISOTROPIC RADIATED POWER (EIRP)

- The following shall be applied to the combination(s) of the radio device and its intended antenna(e).
- If the RF level is user adjustable, all measurements shall be made with the highest power level available to the user for that combination.
- The following method of measurement shall apply to both conducted and radiated measurements.
- The radiated measurements are performed at the Ultratech Calibrated Open Field Test Site.
- The measurement shall be performed using normal operation of the equipment with modulation.

Test procedure shall be as follows:

Step 1: Duty Cycle measurements

- Using a spectrum analyzer with the frequency span set to 0 Hz and the sweep time set at a suitable value to capture the envelope peaks and the duty cycle of the transmitter output signal;
- The duty cycle of the transmitter, $x = \text{Tx on} / (\text{Tx on} + \text{Tx off})$ with $0 < x < 1$, is measure and recorded in the test report. For the purpose of testing, the equipment shall be operated with a duty cycle that is equal or more than 0.1.

Step 2: Calculation of Peak and Average EIRP

- The peak output power of the transmitter shall be determined using a wideband, calibrated RF Peak Power Meter with the power sensor with an integration period that exceeds the repetition period of the transmitter by a factor 5 or more. The observed value shall be recorded as “P” (in dBm);
- The Average EIRP shall be calculated from the above measured power output “A”, the observed duty cycle x, and the applicable antenna assembly gain “G” in dBi, according to the formula:

$$\text{Peak EIRP} = P + G$$

$$\text{Average EIRP} = \text{Peak EIRP} + 10\log(1/x)$$

Figure 1

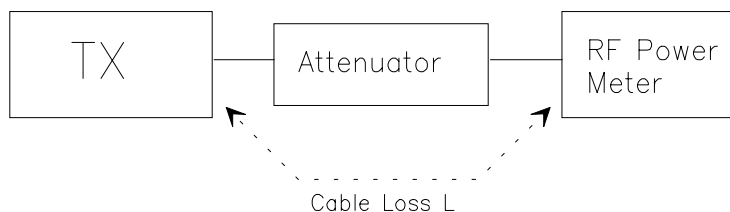

ULTRATECH GROUP OF LABS

3000 Bristol Circle, Oakville, Ontario, Canada L6H 6G4

Tel. #: 905-829-1570, Fax. #: 905-829-8050, Email: vic@ultratech-labs.com, Website: http://www.ultratech-labs.com

File #: MIC46-FTX
January 24, 2002

- Assessed by ITI (UK) Competent Body, NVLAP (USA) Accreditation Body & ACA/AUSTEL (Australia), VCCI (Japan)
- Accredited by Industry Canada (Canada) under ACC-LAB (Europe/Canada MRA and APEC/Canada MRA)
- Recognized/Listed by FCC (USA)
- All test results contained in this engineering test report are traceable to National Institute of Standards and Technology (NIST)

Step 3: Substitution Method. See Figure 2

- (a) The measurements was performed in the absence of modulation (un-modulated)
- (b) Test was performed at listed 3m open area test site (listed with FCC, IC, ITI, NVLAP, ACA & VCCI).
- (c) The transmitter under test was placed at the specified height on a non-conducting turntable (80 cm height)
- (d) The dipole test antenna was used and tuned to the transmitter carrier frequency.
- (e) The spectrum analyzer was tuned to transmitter carrier frequency. The test antenna was lowered or raised from 1 to 4 meters until the maximum signal level was detected.
- (f) The transmitter was rotated through 360° about a vertical axis until a higher maximum signal was received.
- (g) The test antenna was lowered or raised again from 1 to 4 meters until a maximum was obtained. This level was recorded.
- (h) The substitution dipole antenna and the signal generator replaced the transmitter and antenna under test in the same position, and the substitution dipole antenna was placed in vertical polarization. The test dipole antenna was lowered or raised as necessary to ensure that the maximum signal is stilled received.
- (i) The input signal to the substitution antenna was adjusted in level until an equal or a known related level to that detected from the transmitter was obtained in the test receiver. The maximum carrier radiated power is equal to the power supply by the generator.
- (j) The substitution antenna gain and cable loss were added to the signal generator level for the corrected ERP level.
- (k) Repeat steps (c) to (j) with the substitution antenna oriented in horizontal polarization.
- (l) Actual gain of the EUT's antenna is the difference of the measured ERP and measured RF power at the RF port. Correct the antenna gain if necessary.

Figure 2

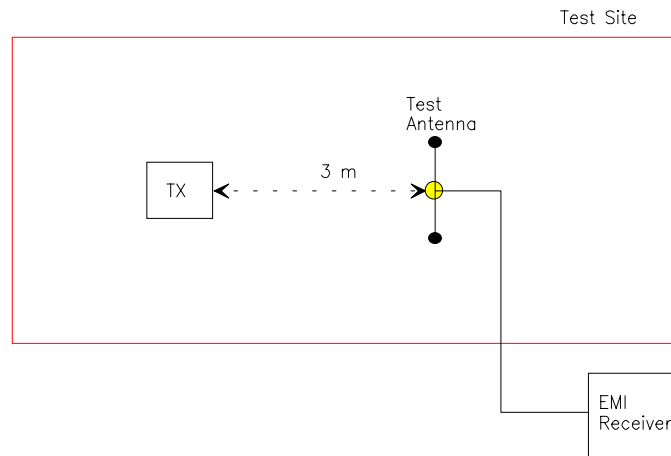

ULTRATECH GROUP OF LABS

3000 Bristol Circle, Oakville, Ontario, Canada L6H 6G4

Tel. #: 905-829-1570, Fax. #: 905-829-8050, Email: vic@ultratech-labs.com, Website: <http://www.ultratech-labs.com>

File #: MIC46-FTX
January 24, 2002

- Assessed by ITI (UK) Competent Body, NVLAP (USA) Accreditation Body & ACA/AUSTEL (Australia), VCCI (Japan)
- Accredited by Industry Canada (Canada) under ACC-LAB (Europe/Canada MRA and APEC/Canada MRA)
- Recognized/Listed by FCC (USA)
- All test results contained in this engineering test report are traceable to National Institute of Standards and Technology (NIST)

Figure 3

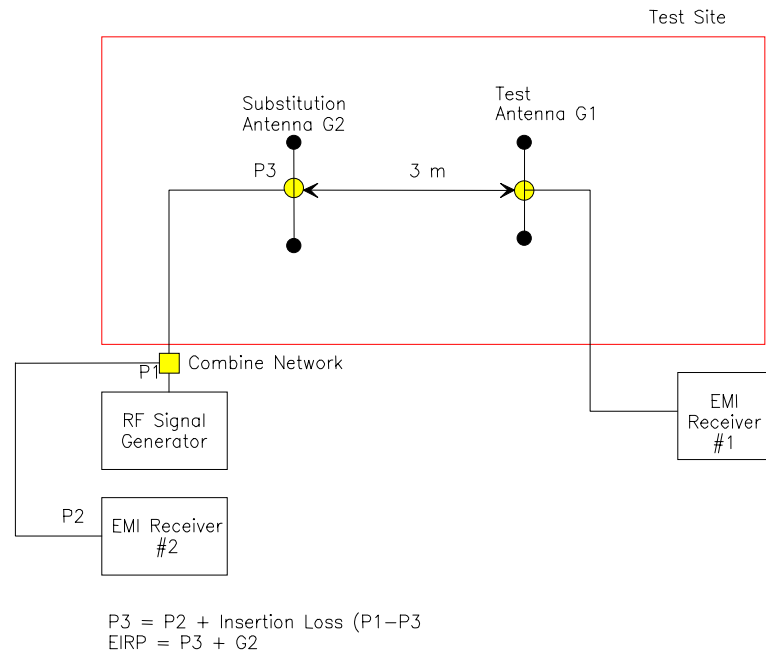

Use the following spectrum analyzer settings:

- Span = approximately 5 times the 20 dB BW, centered on a hopping channel
- RBW > 20 dB BW of the emission measured
- VBW = RBW
- Trace = max hold
- Allow the trace to stabilize
- Use the marker-to-marker function to set the marker to the peak of the emission.
- The indicated level is the peak output power (with the addition of the external attenuation and cable loss).
- The limit is specified in one of the subparagraphs of this Section.
- Submit this plot.
- A peak responding power meter may be used instead of a spectrum analyzer.

ULTRATECH GROUP OF LABS

3000 Bristol Circle, Oakville, Ontario, Canada L6H 6G4

Tel. #: 905-829-1570, Fax. #: 905-829-8050, Email: vic@ultratech-labs.com, Website: <http://www.ultratech-labs.com>

File #: MIC46-FTX
January 24, 2002

- Assessed by ITI (UK) Competent Body, NVLAP (USA) Accreditation Body & ACA/AUSTEL (Australia), VCCI (Japan)
- Accredited by Industry Canada (Canada) under ACC-LAB (Europe/Canada MRA and APEC/Canada MRA)
- Recognized/Listed by FCC (USA)
- All test results contained in this engineering test report are traceable to National Institute of Standards and Technology (NIST)

8.4. SPURIOUS EMISSIONS (CONDUCTED & RADIATED)

For both conducted and radiated measurements, the spurious emissions were scanned from the lowest frequency generated by the EUT or 10 MHz whichever is lower to 10th harmonic of the highest frequency generated by the EUT.

8.4.1. Band-Edge and Spurious Emissions (Conducted)

Band-Edge Compliance of RF Conducted Emissions:

Use the following spectrum analyzer settings:

- The radio was connected to the measuring equipment via a suitable attenuator.
- Span = wide enough to capture the peak level of the emission operating on the channel closest to the band-edge, as well as any modulation products which fall outside of the authorized band of operation.
- RBW = 1 % of the span
- VBW = RBW
- Sweep = auto
- Detector function = peak
- Trace = max hold
- Allow the trace to stabilize
- Set the marker on the emission at the band-edge, or on the highest modulation product outside of the band, if this level is greater than that at the band-edge
- Enable the marker-delta function, then use the marker-to-peak function to move the marker to the peak of the in-band emission.
- The marker-delta value now displayed must comply with the limit specified
- Now, using the same instrument settings, enable the hopping function of the EUT
- Allow the trace to stabilize
- Follow the same procedure listed above to determine if any spurious emissions cause by the hopping function also comply with the specify limits.
- Submit this plot

Spurious RF Conducted Emissions:

Use the following spectrum analyzer settings:

- The radio was connected to the measuring equipment via a suitable attenuator.
- Span = wide enough to capture the peak level of the in-band-emission and all spurious emissions (e.g. harmonics) from the lowest frequency generated in the EUT up through the 10th harmonic. Typically, several plots are required to cover this entire span.
- RBW = 100 kHz
- VBW = RBW
- Sweep = auto
- Detector function = peak
- Trace = max hold
- Allow the trace to stabilize
- Set the marker on the any spurious emission recorded. The level displayed must comply with the limit specified in this Section.
- Submit this plot

ULTRATECH GROUP OF LABS

3000 Bristol Circle, Oakville, Ontario, Canada L6H 6G4

Tel. #: 905-829-1570, Fax. #: 905-829-8050, Email: vic@ultratech-labs.com, Website: <http://www.ultratech-labs.com>

File #: MIC46-FTX
January 24, 2002

- Assessed by ITI (UK) Competent Body, NVLAP (USA) Accreditation Body & ACA/AUSTEL (Australia), VCCI (Japan)
- Accredited by Industry Canada (Canada) under ACC-LAB (Europe/Canada MRA and APEC/Canada MRA)
- Recognized/Listed by FCC (USA)
- All test results contained in this engineering test report are traceable to National Institute of Standards and Technology (NIST)

8.4.2. Spurious Emissions (Radiated)

- The radiated emission measurements were performed at the UltraTech's 3 Meter Open Field Test Site (OFTS) situated in the Town of Oakville, province of Ontario. The Attenuation Characteristics of OFTS have been filed to FCC, Industry Canada, ACA/Austel, NVLap and ITI.
- Radiated emissions measurements were made using the following test instruments:
 1. Calibrated EMCO BiconiLog antenna in the frequency range from 30 MHz to 2000 MHz.
 2. Calibrated Emco Horn antennas in the frequency range above 1000 MHz (1GHz - 40 GHz).
 3. The test is required for any spurious emission or modulation product that falls in a Restricted Band, as defined in Section 15.205. It must be performed with the highest gain of each type of antenna proposed for use with the EUT. Use the following spectrum analyzer settings:
 - RBW = 100 kHz for $f < 1\text{GHz}$ and RBW = 1 MHz for $f \geq 1\text{ GHz}$
 - VBW = RBW
 - Sweep = auto
 - Detector function = peak
 - Trace = max hold
 - Follows the guidelines in ANSI C63.4-1992 with respect to maximizing the emission by rotating the EUT, measuring the emission while the EUT is situated in three orthogonal planes (if appropriate), adjusting the measurement antenna height and polarization, etc.. A pre-amp and highpass filter are required for this test, in order to provide the measuring system with sufficient sensitivity.
 - Allow the trace to stabilize.
 - The peak reading of the emission, after being corrected by the antenna correction factor, cable loss, pre-amp gain, etc.... is the peak field strength which comply with the limit specified in Section 15.35(b)

Calculation of Field Strength:

The field strength is calculated by adding the calibrated antenna factor and cable factor, and subtracting the Amplifier gain (if any) from the measured reading. The basic equation with a sample calculation is as follows:

$$FS = RA + AF + CF - AG$$

Where FS = Field Strength
RA = Receiver/Analyzer Reading
AF = Antenna Factor
CF = Cable Attenuation Factor
AG = Amplifier Gain

Example: If a receiver reading of 60.0 dBuV is obtained, the antenna factor of 7.0 dB/m and cable factor of 1.0 dB are added, and the amplifier gain of 30 dB is subtracted. The actual field strength will be:

$$\begin{aligned} \text{Field Level} &= 60 + 7.0 + 1.0 - 30 = 38.0 \text{ dBuV/m.} \\ \text{Field Level} &= 10^{(38/20)} = 79.43 \text{ uV/m.} \end{aligned}$$

ULTRATECH GROUP OF LABS

3000 Bristol Circle, Oakville, Ontario, Canada L6H 6G4
Tel. #: 905-829-1570, Fax. #: 905-829-8050, Email: vic@ultratech-labs.com, Website: http://www.ultratech-labs.com

File #: MIC46-FTX
January 24, 2002

- Assessed by ITI (UK) Competent Body, NVLAP (USA) Accreditation Body & ACA/AUSTEL (Australia), VCCI (Japan)
- Accredited by Industry Canada (Canada) under ACC-LAB (Europe/Canada MRA and APEC/Canada MRA)
- Recognized/Listed by FCC (USA)
- All test results contained in this engineering test report are traceable to National Institute of Standards and Technology (NIST)

- Submit this test data
- Now set the VBW to 10Hz, while maintaining all of the other instrument settings. This peak level, once corrected, must comply with the limit specified in Section 15.209. If the dwell time per channel of the hopping signal is less than 100ms, then the reading obtained may be further adjusted by a “duty cycle correction factor”, derived from $10\log(\text{dwell time}/100\text{mS})$ in an effort to demonstrate compliance with the 15.209.
- Submit test data

Maximizing The Radiated Emissions:

- The frequencies of emissions was first detected. Then the amplitude of the emissions was measured at the specified measurement distance using required antenna height, polarization, and detector characteristics.
- During this process, cables and peripheral devices were manipulated within the range of likely configuration.
- For each mode of operation required to be tested, the frequency spectrum was monitored. Variations in antenna heights (from 1 meter to 4 meters above the ground plane), antenna polarization (horizontal plane and vertical plane), cable placement and peripheral placement were explored to produce the highest amplitude signal relative to the limit.

The maximum radiated emission for a given mode of operation was found by using the following step-by-step procedure:

- Step1: Monitor the frequency range of interest at a fixed antenna height and EUT azimuth.
- Step2: Manipulate the system cables to produce highest amplitude signal relative to the limit. Note the amplitude and frequency of the suspect signal.
- Step3: Rotate the EUT 360 degrees to maximize the suspected highest amplitude signal. If the signal or another at a different frequency is observed to exceed the previously noted highest amplitude signal by 1 dB or more, go back to the azimuth and repeat Step 2. Otherwise, orient the EUT azimuth to repeat the highest amplitude observation and proceed.
- Step4: Move the antenna over its full allowable range of travel (1 to 4 meters) to maximize the suspected highest amplitude signal. If the signal or another at a different frequency is observed to exceed the previously noted highest amplitude signal by 1 dB or more, return to Step 2 with the highest amplitude observation and proceed.
- Step5: Change the polarization of the antenna and repeat Step 2 through 4. Compare the resulting suspected highest amplitude signal with that found for the other polarization. Select and note the higher of the two signals. This signal is termed the highest observed signal with respect to the limit for this EUT operational mode.
- Step6: The effects of various modes of operation is examined. This is done by varying the equipment modes as steps 2 through 5 are being performed.
- Step7: After completing steps 1 through 6, record the final highest emission level, frequency, antenna polarization and detector mode of the measuring instrument.

ULTRATECH GROUP OF LABS

3000 Bristol Circle, Oakville, Ontario, Canada L6H 6G4

Tel. #: 905-829-1570, Fax. #: 905-829-8050, Email: vic@ultratech-labs.com, Website: <http://www.ultratech-labs.com>

File #: MIC46-FTX
January 24, 2002

- Assessed by ITI (UK) Competent Body, NVLAP (USA) Accreditation Body & ACA/AUSTEL (Australia), VCCI (Japan)
- Accredited by Industry Canada (Canada) under ACC-LAB (Europe/Canada MRA and APEC/Canada MRA)
- Recognized/Listed by FCC (USA)
- All test results contained in this engineering test report are traceable to National Institute of Standards and Technology (NIST)

8.5. ALTERNATIVE TEST PROCEDURES

If the antenna conducted tests cannot be performed on this device, radiated tests show compliance with the peak output power limit specified in Section 15.247(b) and the spurious RF conducted emission limit specified in Section 15.247(c) are acceptable. As stated previously, a pre-amp, and, in the later case, a high pass filter, are required for the following measurements:

8.5.1. Peak Power Measurements

Calculate the transmitter's peak power using the following equation:

$$E = 30PG/d$$
$$P = (Ed)^2/30G$$

Where:

- E: measured maximum fundamental field strength in V/m. Utilizing a RBW, the 20 dB bandwidth of the emission VBW >RBW, peak detector function. Follow the procedures in C63.4-1992 with respect to maximizing the emission
- G is numeric gain of the transmitting antenna with reference to an isotropic radiator
- D is the distance in meters from which the field strength was measured
- P is the distance in meters from which the field strength was measured

8.5.2. Spurious RF conducted emissions

To demonstrate compliance with the spurious RF conducted emission requirement of Section 15.247(c), use the following spectrum analyzer settings:

- Span = wide enough to fully capture the emission being measured
- RBW = 100 kHz
- Sweep = auto
- Detector function = peak
- Trace = max hold
- Measure the field strength of both the fundamental and all spurious emissions with these settings.
- Follow the procedures C62-4:1994 with respect to maximizing the emissions. The measured field strength of all spurious emissions must be below the measured field strength of the fundamental emission by the amount specified in Section 15.247©. Note that if the emission falls in a Restricted Band, as defined in Section 15.205, the procedure for measuring spurious radiated emissions listed above must be followed

ULTRATECH GROUP OF LABS

3000 Bristol Circle, Oakville, Ontario, Canada L6H 6G4

Tel. #: 905-829-1570, Fax. #: 905-829-8050, Email: vic@ultratech-labs.com, Website: <http://www.ultratech-labs.com>

File #: MIC46-FTX
January 24, 2002

- Assessed by ITI (UK) Competent Body, NVLAP (USA) Accreditation Body & ACA/AUSTEL (Australia), VCCI (Japan)
- Accredited by Industry Canada (Canada) under ACC-LAB (Europe/Canada MRA and APEC/Canada MRA)
- Recognized/Listed by FCC (USA)
- All test results contained in this engineering test report are traceable to National Institute of Standards and Technology (NIST)