

MDS OEM-L/ss

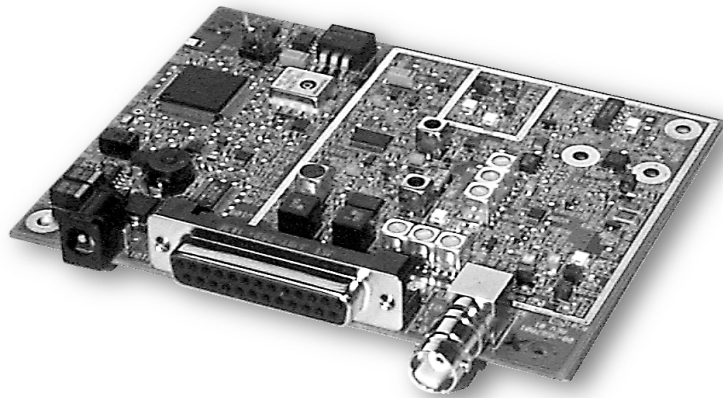

Data Transceiver

MDS 05-3624A01, Rev. A
JUNE 2000

QUICK START GUIDE

Below are the basic steps for installing the transceiver. Detailed instructions are given in “Installation Steps” on page 8 of this guide.

1. Install and connect the antenna system to the radio

- Use good quality, low loss coaxial cable. Keep the feedline as short as possible.
- Preset directional antennas in the direction of desired transmission.

2. Connect the data equipment to the radio’s INTERFACE connector

- Connection to the radio must be made with a DB-25 Male connector. Connections for typical systems are shown below.
- Connect only the required pins. Do not use a straight-through RS-232 cable with all pins wired.
- Verify the data equipment is configured as DTE. (By default, the radio is configured as DCE.)

The markup had a question about this figure. Please verify

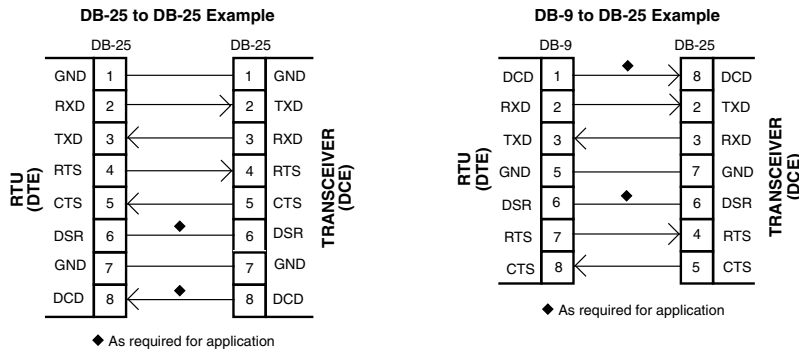

3. Apply DC power to the radio (10–30 Vdc @ 1.5 A minimum)

- Observe proper polarity.

4. Set the radio’s basic configuration with a Hand-Held Terminal (HHT)

- Set the transmit frequency (**TX xxx.xxx**).
- Set the receive frequency (**RX xxx.xxx**).
- Set the network address (**ADDR xxx**).
- Set/verify the data rate using the **BAUD** command. The default setting is **BAUD 9600 8N1**. (Refer to “TRANSCEIVER PROGRAMMING” on page 14 for command details.)

5. Verify proper operation by observing the LED display

- Refer to Table 5 on page 14 for a description of the status LEDs.
- Refine directional antenna headings for maximum receive signal strength using the **RSSI** command.

TABLE OF CONTENTS

1.0 GENERAL.....	1
1.1 Introduction	1
1.2 Differences Among Models	1
1.3 Applications	2
Point-to-Multipoint, Multiple Address Systems (MAS)	2
Point-to-Point System	3
Switched Carrier Operation	4
Single Frequency (Simplex) Operation	4
1.4 Model Number Codes	4
1.5 Accessories	5
2.0 GLOSSARY OF TERMS.....	5
3.0 INSTALLATION	8
3.1 Installation Steps	8
3.2 Mounting the Transceiver Board	9
3.3 Mounting the Enclosed Transceiver	10
3.4 Antennas and Feedlines	10
Feedlines	11
3.5 Power Connection	11
3.6 Data Interface Connections	12
3.7 Power Conservation	12
4.0 OPERATION	13
4.1 LED Indicators	14
5.0 TRANSCEIVER PROGRAMMING	14
5.1 Hand-Held Terminal Connection & Startup	15
5.2 Hand-Held Terminal Setup	16
5.3 Keyboard Commands	17
Entering Commands.....	17
Error Messages	17
5.4 Detailed Command Descriptions	19
ADDR [0–255]	19
AMASK [0000 0000–FFFF FFFF]	19
BAUD [xxxxx abc]	20
CTS [0–255]	20
CTSHOLD [0–60000]	21
DEVICE [DCE CTS KEY]	21
DKEY	21
INIT	22
KEY	22

OWM [XXX...]	22
OWN [XXX...]	22
PWR [L M H]	23
RSSI and RSSI!	23
RX [xxx.xxx]	23
RXTOT [NONE 1–255]	23
SER	24
SREV	24
STAT	24
TOT [1–255 ON OFF]	24
TX [xxx.xxx]	24
6.0 TROUBLESHOOTING	25
6.1 LED Indicators	25
6.2 Event Codes	25
Checking for Alarms—STAT command	25
Major Alarms vs. Minor Alarms	26
Event Code Definitions	26
7.0 TECHNICAL REFERENCE	28
7.1 OEM-L/ss Transceiver Specifications	28
7.2 Bench Testing Setup	29
7.3 Helical Filter Adjustment	30
7.4 Upgrading the Radio's Software	31
Using the Radio Software Upgrade Diskette	31
Using Radio Configuration Software	32
7.5 dBm-Watts-Volts Conversion Chart	33

Copyright Notice

This Installation and Operation Guide and all software described herein are protected by **copyright: ©2000 Microwave Data Systems**, a division of Adaptive Broadband Corporation. All rights reserved.

Microwave Data Systems reserves its right to correct any errors and omissions.

Operational Safety Notices



The radio equipment described in this guide uses radio frequency transmitters. Although the power level is low, the concentrated energy from a directional antenna may pose a health hazard. Do not allow people to come in close proximity to the front of the antenna when the transmitter is operating.

This manual is intended to guide a professional installer to install, operate and perform basic system maintenance on the described radio.

ISO 9001 Registration

Microwave Data Systems' adherence to this internationally accepted quality system standard provides one of the strongest assurances of product and service quality available.

MDS Quality Policy Statement

We, the employees of Microwave Data Systems, are committed to achieving total customer satisfaction in everything we do.

Total Customer Satisfaction in:

- Conception, design, manufacture and marketing of our products.
- Services and support we provide to our internal and external customers.

Total Customer Satisfaction Achieved Through:

- Processes that are well documented and minimize variations.
- Partnering with suppliers who are committed to providing quality and service.
- Measuring our performance against customer expectations and industry leaders.
- Commitment to continuous improvement and employee involvement.

Notice

While every reasonable effort has been made to ensure the accuracy of this manual, product improvements may result in minor differences between the manual and the product shipped to you. If you have additional questions or need an exact specification for a product, please contact our Customer Service Team using the information at the back of this guide. In addition, manual updates can often be found on the MDS Web site at www.microwavedata.com.

1.0 GENERAL

1.1 Introduction

This guide presents installation and operating instructions for the MDS OEM-L/ss family of digital radio transceivers. The radios can be purchased as compact, modular boards that can be completely integrated within remote terminal units (RTUs) and PLC equipment. They are also available packaged in their own enclosures.

These transceivers ([Figure 1](#)) are data telemetry radios designed to operate in a point-to-multipoint environment, such as electric utility Supervisory Control and Data Acquisition (SCADA) and distribution automation, gas field automation, water and wastewater SCADA, and on-line transaction processing applications. They use microprocessor control technology to provide highly reliable communications, even under adverse conditions.

MDS OEM-L/ss radios use continuous-phase frequency shift keying (CPFSK) modulation with root raised cosine filtering with 50% excess bandwidth. Domestic models employ a 4-level modem; ETSI models, a 2-level modem.

The transceiver is designed for trouble-free operation with data equipment provided by many other manufacturers, including remote terminal units (RTUs), programmable logic controllers (PLCs), flow computers, lottery terminals, automatic teller machines, and others.

NOTE: Some features may not be available on all radios, based on the options purchased and the applicable regulations for the region in which the radio will operate.

1.2 Differences Among Models

Since there are more than 2 models, I have made this section more generic. The specific frequency coverages can be listed in the specifications section.

---Van

The OEM-L/ss models are very similar in appearance and functionality. The major differences are over-the-air modem speed and frequency coverage. Domestic models are capable of 9600 bps transmission over the air; ETSI models, 4800 bps. This does *not* affect the local DATA INTERFACE port speed, however. All models accept asynchronous data between 1200 and 19200 bps. The frequency coverages are listed in the specifications. See “OEM-L/ss Transceiver Specifications” on page 28.

NOTE: The frequency coverage cannot be set or changed by the user; it is set at the factory.

Finally, there are some hardware and software differences among the OEM-L/ss models. The operating software is *not* interchangeable among MDS OEM-L/ss radios.

Where are the LEDs? I could not see anything that looked obvious. ---Van

LED INDICATORS (4)

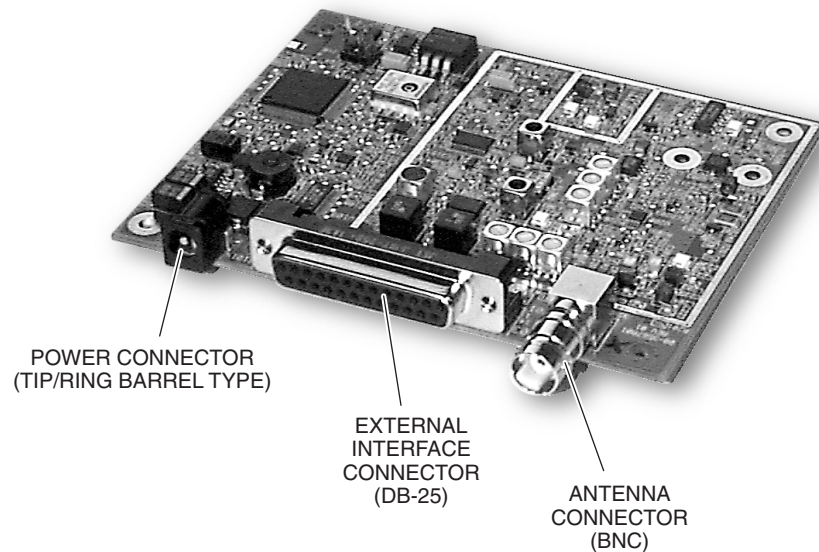

Figure 1. Transceiver Connectors and Indicators

1.3 Applications

Point-to-Multipoint, Multiple Address Systems (MAS)

This is the most common application of the transceiver. It consists of a central master station and several associated remote units as shown in [Figure 2](#). An MAS network provides communications between a central host computer and remote terminal units (RTUs) or other data collection devices. The operation of the radio system is transparent to the computer equipment.

Often, a radio system consists of many widely separated remote radios. A point-to-multipoint or SCADA (Supervisory Control and Data Acquisition) system may be a new installation for automatic, remote monitoring of gas wells, water tank levels, electric power distribution system control and measurement, etc.

The radio system may replace a network of remote monitors currently linked to a central location via leased telephone lines. At the central office of such a system, there is usually a large mainframe computer and some means of switching between individual lines coming from each remote monitor. In this type of system, there is a modulator/demodulator (modem) at the main computer and at each remote site, usually built into the remote monitor itself. Since the cost of leasing a dedicated-pair phone line is quite high, radio is often used as an alternative communication medium.

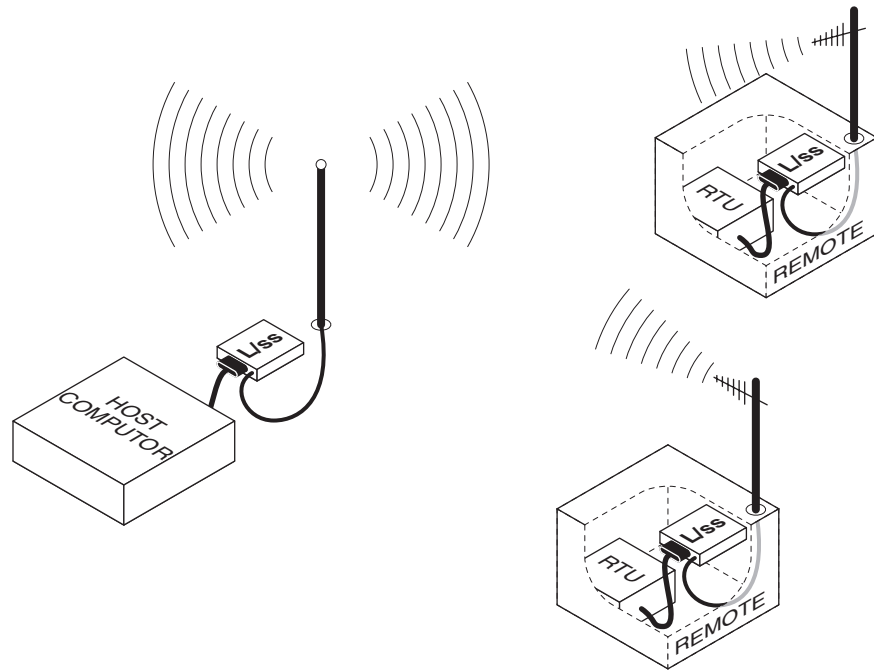

Figure 2. Typical MAS Point-to-Multipoint Network

Point-to-Point System

Where permitted, the transceiver may also be used in a point-to-point arrangement. A point-to-point system consists of just two radios—one serving as a master and the other as a remote—as shown in [Figure 3](#). It provides a simplex or half-duplex communications link for the transfer of data between two locations.

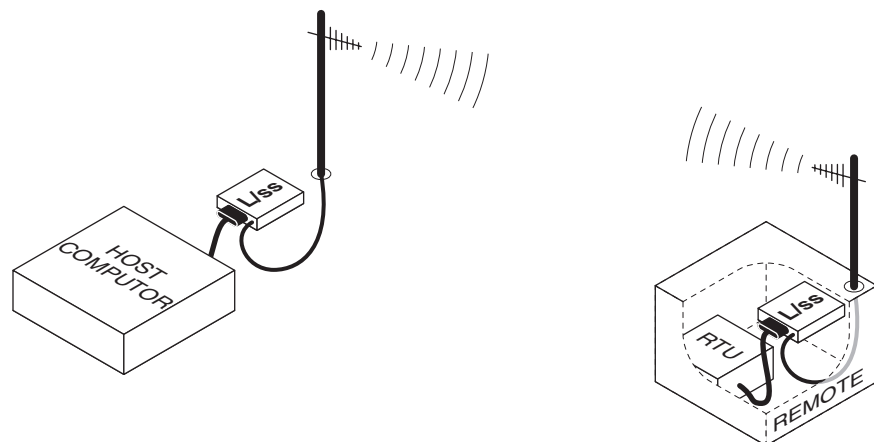

Figure 3. Typical Point-to-Point Link

Switched Carrier Operation

NOTE: MDS OEM-L/ss radios do not support full-duplex operation.

Switched Carrier operation is a half-duplex mode of operation where the master station transmitter is keyed to send data and unkeyed to receive. MDS OEM-L/ss radios operate in switched carrier mode and are keyed on data.

Single Frequency (Simplex) Operation

Single frequency operation (also known as simplex) is a special case of switched carrier operation. Single frequency operation is automatically selected whenever the transmit and receive frequencies are set to the same value.

1.4 Model Number Codes

This section/figure needs to be updated. ---Van

The radio model number is printed on the end of the radio enclosure, and provides key information about how the radio was configured when it was shipped from the factory. See [Figure 4](#) for an explanation of the model number characters.

THIS INFORMATION IS SUBJECT TO CHANGE.

DO NOT USE FOR PRODUCT ORDERING.

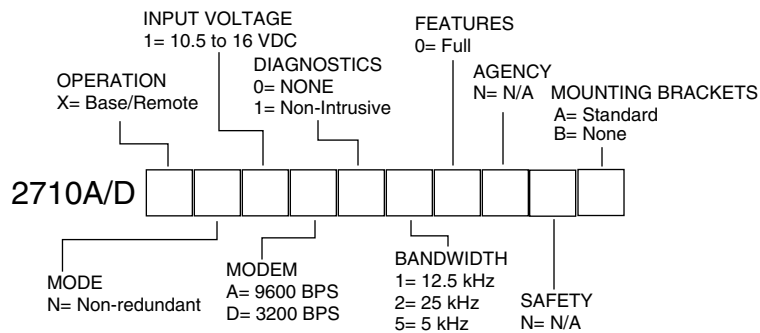

Figure 4. MDS OEM-L/ss Model Number Codes

1.5 Accessories

The transceiver can be used with one or more of the accessories listed in [Table 1](#). Contact Microwave Data Systems for ordering information.

Table 1. MDS OEM-L/ss Optional Accessories

Accessory	Description	MDS P/N
Hand-Held Terminal Kit (HHT)	Terminal that plugs into the radio for programming, diagnostics & control. Includes carrying case and cable set.	02-1501A01
RTU Simulator	Test unit that simulates data from a remote terminal unit. Comes with polling software that runs on a PC. Useful for testing radio operation.	03-2512A01
DB-9 to DB-25 adapter	Used to connect a PC to the radio's DATA INTERFACE port	??-????A??
Radio Configuration Software	Provides diagnostics of the transceiver (Windows-based PC required.)	03-3156A01

2.0 GLOSSARY OF TERMS

If you are new to digital radio systems, some of the terms used in this guide may be unfamiliar. The following glossary explains many of these terms and will prove helpful in understanding the operation of the transceiver.

Antenna System Gain—A figure, normally expressed in dB, representing the power increase resulting from the use of a gain-type antenna. System losses (from the feedline and coaxial connectors, for example) are subtracted from this figure to calculate the total antenna system gain.

Bit—The smallest unit of digital data, often represented by a one or a zero. Eight bits (plus start, stop, and parity bits) usually comprise a byte.

Bits-per-second—See *BPS*.

BPS—Bits-per-second. A measure of the information transfer rate of digital data across a communication channel.

Byte—A string of digital data usually made up of eight data bits and start, stop and parity bits.

Data Circuit-terminating Equipment—See *DCE*.

Data Communications Equipment—See *DCE*.

Data Terminal Equipment—See *DTE*.

dBi—Decibels referenced to an “ideal” isotropic radiator in free space. Frequently used to express antenna gain.

dBm—Decibels referenced to one milliwatt. An absolute unit used to measure signal power, as in transmitter power output, or received signal strength.

DCE—Data Circuit-terminating Equipment (or Data Communications Equipment). In data communications terminology, this is the “modem” side of a computer-to-modem connection. The MDS OEM-L/ss is a DCE device.

Decibel (dB)—A measure computed from the ratio between two signal levels. Frequently used to express the gain (or loss) of a system.

DTE—Data Terminal Equipment. A device that provides data in the form of digital signals at its output. Connects to the DCE device.

Equalization—The process of reducing the effects of amplitude, frequency or phase distortion with compensating networks.

Fade Margin—The greatest tolerable reduction in average received signal strength that will be anticipated under most conditions. Provides an allowance for reduced signal strength due to multipath, slight antenna movement, or changing atmospheric losses. A fade margin of 20 to 30 dB is usually sufficient in most systems.

Frame—A segment of data that adheres to a specific data protocol and contains definite start and end points. It provides a method of synchronizing transmissions.

Hardware Flow Control—A transceiver feature used to prevent data buffer overruns when handling high-speed data from the RTU or PLC. When the buffer approaches overflow, the radio drops the clear-to-send (CTS) line, which instructs the RTU or PLC to delay further transmission until CTS again returns to the high state.

Host Computer—The computer installed at the master station site, which controls the collection of data from one or more remote sites.

Latency—The delay (usually expressed in milliseconds) between when data is applied to TXD (Pin 2) at one radio, until it appears at RXD (Pin 3) at the other radio.

MAS—Multiple Address System. A radio system where a central master station communicates with several remote stations for the purpose of gathering telemetry data.

Master (Station)—Radio which is connected to the host computer. It is the point at which polling enters the network.

Multiple Address System—See *MAS*.

Payload data—This is the application’s user communication data which is sent over the radio network. It is the transfer of payload data that is the primary purpose of the radio communications network.

PLC—Programmable Logic Controller. A dedicated microprocessor configured for a specific application with discrete inputs and outputs. It can serve as a host or as an RTU.

Point-Multipoint System—A radio communications network or system designed with a central control station that exchanges data with a number of remote locations equipped with terminal equipment.

Poll—A request for data issued from the host computer (or master PLC) to a remote radio.

Programmable Logic Controller—See *PLC*.

Received Signal Strength Indication—See *RSSI*.

Redundant Operation—A station arrangement where *two* transceivers and two power supplies are available for operation, with automatic switchover in case of a failure.

Remote (Station)—A radio in a network that communicates with an associated master station.

Remote Terminal Unit—See *RTU*.

RSSI—Received Signal Strength Indication. A measure, in dB, of the strength of the signal received by a radio from an antenna. The radio must be calibrated for the RSSI value to be meaningful.

RTU—Remote Terminal Unit. A data collection device installed at a remote radio site.

SCADA—Supervisory Control And Data Acquisition. An overall term for the functions commonly provided through an MAS radio system.

Standing Wave Ratio—See *SWR*.

Supervisory Control And Data Acquisition—See *SCADA*.

SWR—Standing Wave Ratio. A parameter related to the ratio between forward transmitter power and the reflected power from the antenna system. As a general rule, reflected power should not exceed 10% of the forward power ($\approx 2:1$ SWR).

3.0 INSTALLATION

There are three main requirements for installing the transceiver—adequate and stable primary power, a good antenna system, and the correct data connections between the transceiver and the data device. MDS OEM-L/ss radios are available as stand-alone boards or in small enclosures. **Figure 5** shows the connections that are made to the stand-alone board.

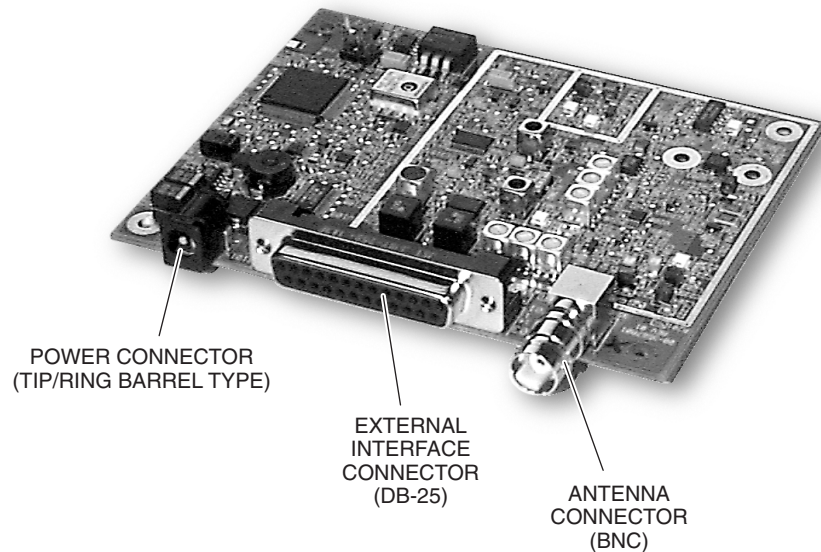

Figure 5. Connections to the Stand-Alone Board

3.1 Installation Steps

Below are the basic steps for installing the transceiver. In most cases, these steps alone are sufficient to complete the installation. More detailed explanations appear at the end of these steps.

1. Mount the transceiver to a stable surface using the brackets supplied with the radio.
2. Install the antenna and antenna feedline for the station. Preset directional antennas in the desired direction.
3. Measure and install the primary power for the radio.

NOTE: Use the radio in negative ground systems only.

4. Set the radio configuration. The transceiver is designed for quick installation with a minimum of software configuration required in most cases. The selections that *must* be made or verified for new installations are:
 - Transmit frequency
 - Receive frequency
 - Network address

The operating frequencies are not set at the factory unless they were specified at the time of order. Determine the transmit and receive frequencies to be used, and follow the steps below to program them.

5. Connect a hand-held terminal (HHT) to the DATA INTERFACE connector. When the HHT beeps, press **ENTER** to receive the ready “>” prompt.
 - a. Set the transmit frequency with the **TX xxx.xxx** command.
Press **ENTER** after the command.
 - b. Set the receive frequency with the **RX xxx.xxx** command.
Press **ENTER** after the command.
 - c. Set the network address with the **ADDR xxx** command.
Press **ENTER** after the command. After programming, the HHT reads **PROGRAMMED OK** to indicate successful entry.
6. Disconnect the HHT from the DATA INTERFACE connector.
7. Connect the data equipment to the transceiver’s DATA INTERFACE connector. Use only the required pins for the application—do *not* use a fully pinned (25 conductor) cable. Basic applications may require only the use of Pin 2 (transmit data—TXD), Pin 3 (Received Data—RXD) and Pin 7 (signal ground).

Additional connections may be required for some installations. Refer to the complete list of pin functions provided in [Table 4 on page 12](#).

3.2 Mounting the Transceiver Board

This is a placeholder for special mounting instructions of the stand-alone board, if necessary.

3.3 Mounting the Enclosed Transceiver

*Is Section 3.3 to be retained in this version of the manual?
---Van*

Figure 6 shows the mounting dimensions of the transceiver.

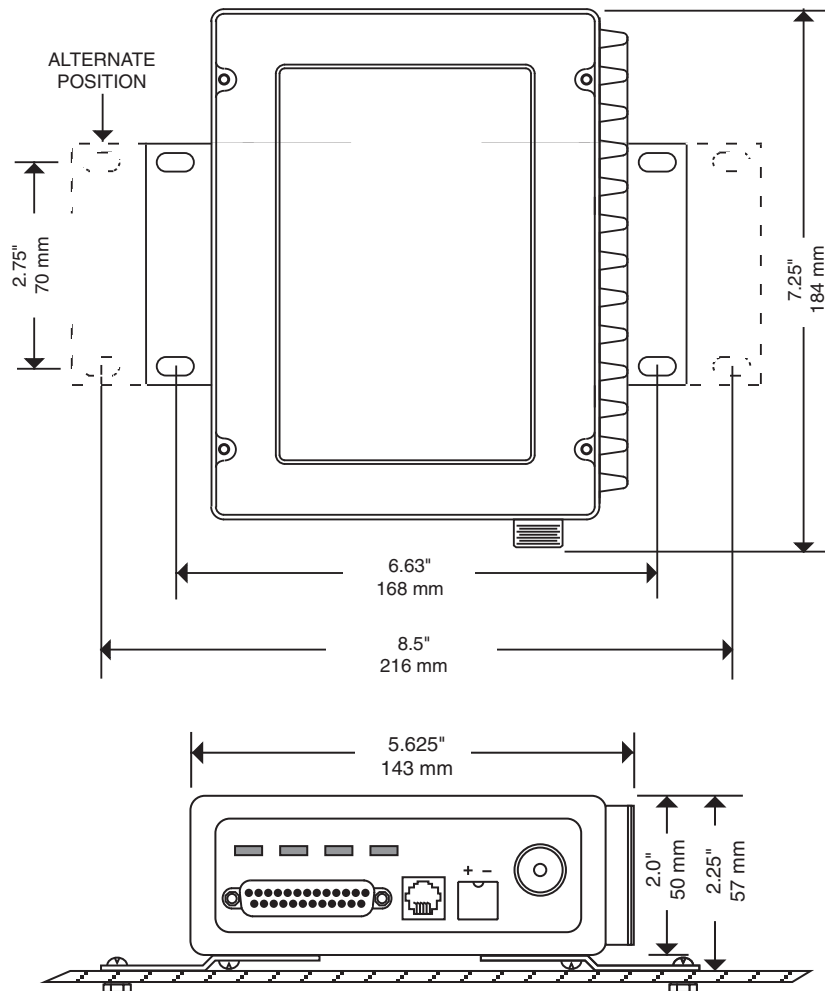

Figure 6. Transceiver Mounting Dimensions

3.4 Antennas and Feedlines

Antennas

The transceiver can be used with a number of antennas. The exact style depends on the physical size and layout of the radio system. At remote sites, a directional Yagi (Figure 7) or corner reflector antenna is generally recommended to minimize interference to and from other users. Antennas of this type are available from several manufacturers.

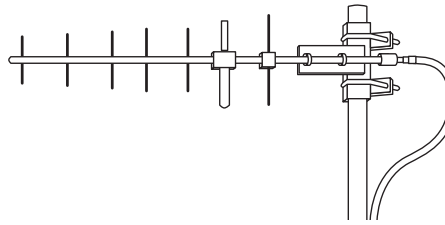

Figure 7. Typical Yagi Antenna (mounted to mast)

Feedlines

The selection of antenna feedline is very important. Poor quality cables should be avoided as they will result in power losses that may reduce the range and reliability of the radio system.

Table 2 shows the losses that will occur when using various lengths and types of cable at 200 MHz; **Table 3**, the losses at 400 MHz. Regardless of the type of cable used, it should be kept as short as possible to minimize signal loss.

Table 2. Length vs. Loss in Coaxial Cables at 200 MHz

Cable Type	3 Meters (10 Feet)	15 Meters (46 Feet)	30 Meters (91 Feet)	150 Meters (525 Feet)
RG-8A/U	0.32 dB	1.6 dB	3.2 dB	16 dB
1/2 inch HELIAX	0.10 dB	0.49 dB	0.98 dB	4.9 dB
7/8 inch HELIAX	0.05 dB	0.27 dB	0.54 dB	2.7 dB
1-1/4 inch HELIAX	0.04 dB	0.20 dB	0.40 dB	2.0 dB
1-5/8 inch HELIAX	0.03 dB	0.17 dB	0.33 dB	1.65 dB

Table 3. Length vs. Loss in Coaxial Cables at 400 MHz

Cable Type	10 Feet (3.05 Meters)	50 Feet (15.24 Meters)	100 Feet (30.48 Meters)	500 Feet (152.4 Meters)
RG-8A/U	0.51dB	2.53 dB	5.07 dB	25.35 dB
1/2 inch HELIAX	0.12 dB	0.76 dB	1.51 dB	7.55 dB
7/8 inch HELIAX	0.08 dB	0.42 dB	0.83 dB	4.15 dB
1-1/4 inch HELIAX	0.06 dB	0.31 dB	0.62 dB	3.10 dB
1-5/8 inch HELIAX	0.05 dB	0.26 dB	0.52 dB	2.60 dB

3.5 Power Connection

The transceiver can be operated from any well-filtered 10 to 30 Vdc power source. The power supply should be capable of providing at least 1 ampere of continuous current.

NOTE: The radio is designed for use only in negative ground systems.

3.6 Data Interface Connections

The transceiver's DATA INTERFACE connector is used to connect the transceiver to an external DTE data terminal that supports the EIA-232 (formally RS-232) format. The transceiver supports asynchronous data rates up to 19200 bps. The data rate at the DATA INTERFACE connector may differ from the data rate over the air.

Table 4 lists each pin on the DATA INTERFACE connector and describes its function.



Do not use a 25 wire (fully pinned) cable for connection to the DATA INTERFACE connector. Use *only* the required pins for the application. Damage may result if improper connections are made. For EIA-232 signaling, typical applications require the use of Pins 1 through 8 *only*.

3.7 Power Conservation

In some installations, such as at solar-powered sites, it may be necessary to keep the transceiver's power consumption to an absolute minimum. This can be accomplished by removing power from the radio. When power is restored, the radio is ready to receive data within 75 milliseconds.

Table 4. DATA INTERFACE Connector Pinouts

Pin Number	Input/Output	Pin Description
1	--	Protective Ground. Connects to ground (negative supply potential) on the radio's PC board and chassis.
2	IN	TXD—Transmitted Data. Accepts TX data from the connected device.
3	OUT	RXD—Received Data. Outputs received data to the connected device.
4	IN	RTS—Request-to-Send Input. Keys the transmitter when RTS is at logic high.
5	OUT	CTS—Clear-to-Send Output. Goes "high" after the programmed CTS delay time has elapsed (DCE) or keys an attached radio when RF data arrives (CTS KEY).
6	OUT	DSR—Data Set Ready. Provides a +6 Vdc DSR signal through a 2.5 kΩ resistor.
7	--	Signal Ground. Connects to ground (negative supply potential) at radio's PC board.
8	OUT	DCD—Data Carrier Detect. Goes "high" when the modem detects a data carrier from the master station.
9	--	Do not connect—Reserved for future use.

Table 4. DATA INTERFACE Connector Pinouts (Continued)

Pin Number	Input/Output	Pin Description
10	--	Do not connect—Reserved for future use.
11	OUT	Receive Audio Output. Connects to the audio input of an external (AFSK) modem. The output impedance is 600 Ω, and the level is factory set to suit most installations. Use Pin 7 for the modem's return lead.
12	--	Do not connect—Reserved for future use.
13	--	Do not connect—Reserved for future use.
14	--	Do not connect—Reserved for future use.
15	--	Do not connect—Reserved for future use.
16	--	Do not connect—Reserved for future use.
17	--	Do not connect—Reserved for future use.
18	IN/OUT	Accessory Power. Unregulated Input/Output. Provides a source of input power for low current accessories. Excessive drain on this connection will trip self-resetting fuse F1 on the transceiver PC board. The voltage at this pin will match the input voltage to the transceiver.
19	OUT	5.8 Vdc Regulated Output. Provides a source of regulated voltage at 100 mA for low power accessories.
20	--	Do not connect—Reserved for future use.
21	--	Do not connect—Reserved for future use.
22	--	Do not connect—Reserved for future use.
23	IN	Auto-Open. A logic high (>4.0 volts) on this pin enables the DATA INTERFACE for normal data operation. A logic low (<0.5 volts) on this pin disables data operation and enables diagnostic operation.
24	--	Do not connect—Reserved for future use.
25	OUT	Alarm. A logic low (less than 0.5 volts) on this pin indicates normal operation. A logic high (greater than 4 volts) indicates that some alarm condition is present. This pin can be used as an alarm output, provided the internal series resistance of 1 kΩ is considered.

4.0 OPERATION

In-service operation of the transceiver is completely automatic. Once the unit has been properly installed and configured, operator actions are limited to observing the front panel LED status indicators for proper operation.

If all parameters are correctly set, operation of the radio can be started by following these steps:

1. Apply DC power to the transceiver.

2. Observe the LED status panel for the proper indications ([Table 5](#)).
3. If not done earlier, refine the antenna heading of the station to maximize the received signal strength (RSSI) from the master station.

Use the **RSSI** command from an HHT connected to the radio's DATA INTERFACE connector.—See [Section 5.0, TRANSCIEVER PROGRAMMING](#). ~~This can also be done with a DC voltmeter as described in [Section 4.2, RSSI Measurement](#).~~

4.1 LED Indicators

[Table 5](#) describes the function of each status LED.



Table 5. LED Status Indicators

LED Name	Description
PWR	<ul style="list-style-type: none"> • Continuous—Power is applied to the radio, no problems detected. • Rapid flash (five times-per-second)—Fault indication. • Flashing once every second—Unit is not programmed. Radio is in Bootloader mode.
DCD	Flashing—Indicates the radio is receiving intermittent data frames.
TXD	An EIA-232 mark signal is being received at the DATA INTERFACE connector.
RXD	An EIA-232 mark signal is being sent out from the DATA INTERFACE connector.

5.0 TRANSCIEVER PROGRAMMING

Programming and control of the transceiver (administrative mode) is performed through the radio's DATA INTERFACE connector with an MDS Hand-Held Terminal (MDS P/N 02-1501A01). This section contains a reference chart ([Table 7](#)) followed by detailed descriptions for each user command.

NOTE: In addition to HHT control, Windows-based software is available (MDS P/N 03-3156A01) to allow diagnostics and programming using a personal computer. An installation booklet and on-line instructions are included with the software. Contact MDS for ordering information.

5.1 Hand-Held Terminal Connection & Startup

This section gives basic information for connecting and using the MDS Hand-Held Terminal. For more information about the terminal, refer also to the instructions included with each HHT kit.

The steps below assume that the HHT has been configured for use with the transceiver (80 character screen display). If the HHT was previously used with a different model transceiver, or if its default settings have been changed, refer to *Section 5.2, Hand-Held Terminal Setup* for setup details.

Follow these steps to connect the HHT:

1. Connect the HHT's coiled cord to the DATA INTERFACE (DB-25) connector on the radio as shown in [Figure 8](#). Pin 23 of the HHT cable must be grounded to enable the diagnostic channel. (See [Table 4](#).) This automatically places the radio into the control and programming mode.
2. When the HHT is connected, it runs through a brief self-check, ending with a beep. After the beep, press **ENTER** to obtain the ready ">" prompt.

I am guessing here about the look of the connector. If this is way off, I would like to look at the real thing during my next visit.
---Van

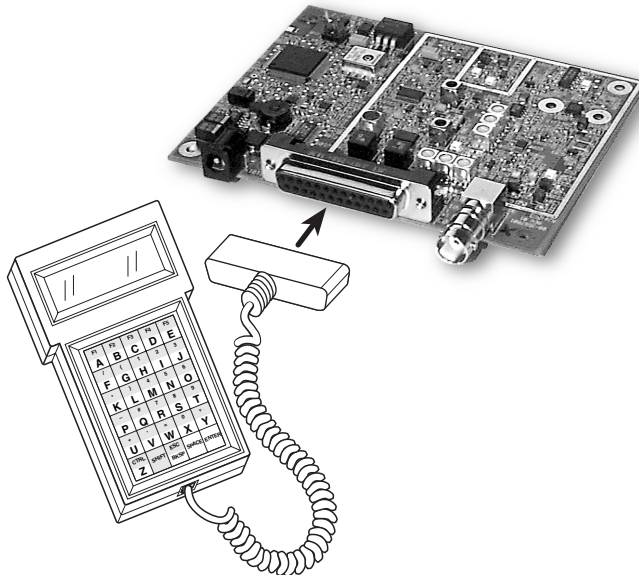

Figure 8. Hand-Held Terminal Connected to the Transceiver

5.2 Hand-Held Terminal Setup

The following is a set of instructions for re-initializing an HHT for use with the transceiver. These steps may be required if the HHT was previously used with a different radio, or if the HHT default settings have been inadvertently altered.

1. Plug the HHT into the DATA INTERFACE connector. Enable the setup mode by pressing the **SHIFT**, **CTRL** and **SPACE** keys in sequence. The display shown in [Figure 9](#) appears.

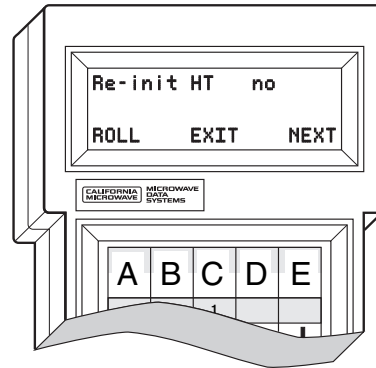

Figure 9. HHT Setup Display

2. The first of 15 menu items is displayed. Settings are reviewed by pressing the NEXT function controlled by the **E** key. Parameter settings are changed by pressing the ROLL function controlled by the **A** key.
3. Set up the HHT as listed in [Table 6](#).

Table 6. HHT Operational Settings

Parameter	Setting	Parameter	Setting
Re-init HT	NO	Scroll On	33rd
Baud Rate	9600	Cursor	ON
Comm bits	8,1,n	CRLF for CR	OFF
Parity Error	OFF	Self Test	FAST
Key Repeat	OFF	Key Beep	ON
Echo	OFF	Screen Size	80
Shift Keys	YES	Menu Mode	LONG
Ctl Chars	PROCS		

5.3 Keyboard Commands

Table 7 is a reference chart of software commands for the transceiver. Programmable information is shown in brackets [] following the command name. See *Section 5.4, Detailed Command Descriptions* for detailed command descriptions.

Entering Commands

To enter a command, type the command, followed by an **ENTER** key-stroke. For programming commands, the command is followed by **SPACE** and the appropriate information or values, then **ENTER**.

Here are some additional points to remember when using the HHT:

- Use the **SHIFT** key to access numbers; press again to return to letter mode.
- Use the **ESC/BKSP** key to edit information or commands entries.
- The flashing square cursor (▣) indicates that letter mode is selected.
- The flashing superscript rectangular cursor (≡) indicates that number mode is selected.

Error Messages

Listed below are some possible error messages that may be encountered when using the HHT:

UNKNOWN COMMAND—The command was not recognized. Refer to the command description for command usage information.

INCORRECT ENTRY—The command format or its associated values were not valid. Refer to the command description for command usage information.

COMMAND FAILED—The command was unable to successfully complete. This may indicate an internal software problem.

NOT PROGRAMMED—Software was unable to program the internal radio memory or the requested item was not programmed. This is a serious internal radio error. Contact MDS for assistance.

TEXT TOO LONG—Response to **OWN** or **OWM** command when too many characters have been entered. Refer to the command description for command usage information.

NOT AVAILABLE—The entered command or parameter was valid, but it referred to a currently unavailable choice. Refer to the command description for command usage information.

ACCESS DENIED—The command is unavailable to the user. Refer to the command descriptions for command information.

EEPROM FAILURE— The **INIT** command was unable to write to EEPROM. This is a serious internal radio error. Contact MDS for assistance.

Table 7. Command summary

Command name	Function
ADDR [0–255] <i>Details page 19</i>	Set or display the network address of the radio.
AMASK [0000 0000–FFFF FFFF] <i>Details page 19</i>	Set or display hex code identifying which events trigger an alarm.
BAUD [xxxxx abc] <i>Details page 20</i>	Set or display the DATA INTERFACE data rate and control bits.
CTS [0–255] <i>Details page 20</i>	Set or display the Clear-to-Send delay in milliseconds.
CTSHOLD [0–60000] <i>Details page 21</i>	Set or display the delay, in milliseconds, at the end of a CTS line response; CTS Key operation only.
DEVICE [DCE CTS KEY] <i>Details page 21</i>	Set or display the device behavior of the radio.
DKEY <i>Details page 21</i>	Dekey the radio (transmitter OFF). This is generally a radio test command.
INIT <i>Details page 22</i>	Set radio parameters to factory defaults.
KEY <i>Details page 22</i>	Key the radio (transmitter ON). This is generally used for radio testing.
OWM [XXX...] <i>Details page 22</i>	Set or display the owner's message.
OWN [XXX...] <i>Details page 22</i>	Set or display the owner's name.
PWR [L M H] <i>Details page 23</i>	Set or display the transmit power setting.
RSSI and RSSI! <i>Details page 23</i>	Display the Received Signal Strength Indication.
RX [xxx.xxx] <i>Details page 23</i>	Set or display the receive frequency.
RXTOT [NONE 1–255] <i>Details page 23</i>	Set or display the value of the receive time-out timer.
SER <i>Details page 24</i>	Display the radio serial number.
SREV <i>Details page 24</i>	Display the software revision level.

Table 7. Command summary (Continued)

Command name	Function
STAT <i>Details page 24</i>	Display the current alarm status.
TOT [1–255 ON OFF] <i>Details page 24</i>	Set or display the time-out timer status and the timer delay in milliseconds.
TX [xxx.xxx] <i>Details page 24</i>	Set or display the transmit frequency.

5.4 Detailed Command Descriptions

The only *critical* commands for most applications are transmit frequency (**TX xxx.xxx**), receive frequency (**RX xxx.xxx**), and network address (**ADDR xxx**). However, proper use of the additional commands allows you to tailor the transceiver for a specific use or conduct basic diagnostics on the radio. This section gives more detailed information for the user commands previously listed in [Table 7](#).

In many cases, the commands shown here can be used in two ways. First, you can type *only* the command name to view the currently programmed data. Secondly, you can set or change the existing data by typing the command, followed by a space, and then the desired entry. In the list below, allowable data values, if any, are shown in brackets following the command name. The separation of values by pipes (|) indicates that you can enter one of the values in the list.

ADDR [0–255]

The **ADDR** command displays or sets the network address of the radio. In order for all the radios in a network to communicate, their network addresses must be identical.

AMASK [0000 0000–FFFF FFFF]

The **AMASK** (alarm mask) command displays or sets which events cause the alarm output signal to be active. Normally, the mask is **FFFF FFFF**, meaning that any of the 32 possible events will activate the alarm output signal. No special configuration is required for typical applications.

Entering the **AMASK** command alone displays the current setting of alarm events in hexadecimal format.

Entering the **AMASK** command followed by an eight-digit hexadecimal number reprograms the specified events to trigger an alarm.

Each bit that is a ‘1’ identifies an associated alarm condition that can trigger the alarm output status line. Each bit that is a ‘0’ treats the associated alarm as irrelevant when deciding whether or not to assert the alarm output status line.

Thus, an eight-digit hexadecimal number can classify up to 32 events as alarm triggers for the alarm output status line. See [Table 8 on page 26](#) for a list of the event codes and their hex values. The hex value of the mask is simply the sum of the hex values of the event codes corresponding to the alarm triggering events.

BAUD [xxxxx abc]

This command sets (or displays) the communication attributes for the DATA INTERFACE port.

The first parameter (**xxxxx**) is baud rate. Baud rate is specified in bits-per-second (bps) and must be one of the following speeds: 1200, 2400, 4800, 9600, or 19200.

The second parameter of the **BAUD** command (**abc**) is a three-character block indicating how the data is encoded:

- a** = Data bits (7 or 8)
- b** = Parity (N for None, O for Odd, E for Even)
- c** = Stop bits (1 or 2)

The factory default setting is 9600 baud, 8 data bits, no parity, 1 start bit, and 1 stop bit (Example: **9600 8N1**).

NOTE: 7N1, 8O2, and 8E2 are invalid communication settings and are not supported by the transceiver.

CTS [0–255]

The **CTS** (clear-to-send) command sets or displays the timer value associated with the CTS line response. The command parameter ranges from 0 to 255 milliseconds.

For DCE operation (see **DEVICE** command), the timer specifies how long to wait after the RTS line goes high, before the radio asserts CTS and the DTE can transmit the data. A **CTS** value of zero keys the radio and asserts the CTS line immediately after the RTS line goes high.

For CTS Key operation (see **DEVICE** command), the timer specifies how long to wait after asserting the CTS, before sending data out the DATA INTERFACE port. A timer value of zero means that data will be sent out the data port without imposing a key-up delay. (Other delays may be present, based on selected radio operating parameters.)

CTSHOLD [0–60000]

For CTS Key operation (see **DEVICE** command), the **CTSHOLD** command sets or displays the timer value associated with the end of a CTS line response. The timer value specifies the length of time that CTS remains following the transmission of the last character from the RXD pin of the DATA INTERFACE port. The time is in milliseconds. The default value is 0, which means that CTS drops immediately after the last character is transmitted.

For DCE operation (see **DEVICE** command), this command has no effect. The response **CTSHOLD n/a** is displayed.

DEVICE [DCE | CTS KEY]

The **DEVICE** command sets or displays the device behavior of the radio. The command parameter is either **DCE** or **CTS KEY**.

The default selection is **DCE**. In this mode, CTS goes high following RTS, subject to the CTS programmable delay time. Keying is stimulated by the input of characters at the data port. Hardware flow control is implemented by signaling the CTS line if data arrives faster than it can be buffered and transmitted.

If **CTS KEY** is selected, the radio is assumed to be controlling another radio. The RTS line is ignored and the CTS line is used as a keyline control for the other radio. CTS is asserted immediately following the receipt of RF data, but data is not sent out the DATA INTERFACE port until the CTS programmable delay time has expired. (This gives the other radio time to key.)

DKEY

This command deactivates the transmitter after it has been keyed with the **KEY** command.

NOTE: The DKEY and KEY commands are *not* intended for normal operation. They are tools for field testing and installation.

INIT

The **INIT** command is used to re-initialize the radio's operating parameters to the factory defaults. This may be helpful when trying to resolve configuration problems that may have resulted from the entry of one or more improper command settings. Entry of this command allows you to get back to a known working state. The following changes to the radio are made when **INIT** is entered:

- **AMASK** is set to **FFFF FFFF**
- **BAUD** is set to 9600 baud, 8 data bits, no parity, and 1 stop bit (**9600 8N1**)
- **CTS** is set to **0**
- **CTSHOLD** is set to **0**
- **DEVICE** is set to **DCE**
- **PWR** is set to **H** [+33 dBm (2 watts)]
- **RXTOT** is set to **NONE**
- **TOT** is set to **OFF**

All other commands stay at their previously established settings.

KEY

This command activates the transmitter. The transmitter stays keyed until either the **DKEY** command is entered, or the transmitter time-out timer is enabled and times out. See also the **DKEY** and **TOT** commands.

NOTE: The **KEY** and **DKEY** commands are *not* intended for normal operation. They are tools for field testing and installation.

OWM [XXX...]

This is a command to display or set an owner's message. To program the owner's message, type **OWM** then the message, followed by **ENTER**. The maximum number of characters that can be entered is 30.

To display the owner's message, type **OWM** then **ENTER**. The owner's message appears on the display.

OWN [XXX...]

This is a command to display or set an owner's name. To program the owner's name, type **OWN** then the name, followed by **ENTER**. The maximum number of characters that can be entered is 30.

To display the owner's name, type **OWN** then **ENTER**. The owner's name appears on the display.

PWR [L | M | H]

NOTE: This function may not be available, depending on certification requirements for a particular region.

This command displays or sets the desired RF forward output power setting of the radio. The **PWR** command parameter is specified as **L** (low), **M** (medium), or **H** (high). The default setting is **H**. The values of **L**, **M**, and **H** are determined by factory calibration. Typically they are:

L = 20 dBm (100 mW)

M = 30 dBm (1 W)

H = 33 dBm (2 W)

RSSI and RSSI!

These commands continuously display the radio's Received Signal Strength Indication (RSSI) in dBm units. Incoming signal strengths from -50 dBm to -120 dBm are displayed.

The **RSSI** command causes the diagnostic port to enter an RSSI update mode. The port displays an updated RSSI output line at intervals of approximately 1 second. Press **ENTER** to terminate the display.

The **RSSI!** command displays a one-time reading of the RSSI at the diagnostic port.

NOTE: The RSSI reading is valid only if the unit has been properly calibrated.

RX [xxx.xxx]

It was unclear from the markup whether there should be something or nothing in the second paragraph under RX.

This command sets or displays the radio's receive frequency in MHz. The frequency must be an integer multiple of the step size and must be in the valid range. If the entered frequency is invalid, the HHT displays the message **INCORRECT ENTRY**.

There is no factory default. **RX** is factory set to customer order.

RXTOT [NONE | 1–255]

The **RXTOT** command sets or displays the receive time-out timer value in minutes. This timer triggers an alarm (event 12) if data is not detected within the specified time.

Entering the **RXTOT** command without a parameter displays the timer value in minutes. Entering the **RXTOT** command with a parameter ranging from 1 to 255 resets the timer in minutes. Entering the **RXTOT** command with the parameter **NONE** disables the timer.

SER

This command displays the radio's serial number as recorded at the factory.

SREV

This command displays the software revision level of the transceiver firmware.

STAT

This command displays the current alarm status of the transceiver.

If no alarms exist, the message **NO ALARMS PRESENT** appears at the top of the HHT display.

If an alarm does exist, a two-digit code (00–31) is displayed and the alarm is identified as **MAJOR** or **MINOR**. A brief description of the alarm code is also given. Detailed descriptions of event codes are provided in [Table 8 on page 26](#).

If more than one alarm exists, the word **MORE** appears at the bottom of the screen and additional alarms are viewed by pressing the **ENTER** key. Alarms are displayed in ascending order, major alarms before minor ones.

TOT [1–255 | ON | OFF]

This command sets or displays the transmitter time-out timer value (1–255 seconds), as well as the timer status (**ON** or **OFF**). The command parameter can be either the timer value or the status, but not both. The parameter **ON** enables the timer; **OFF** disables the timer.

If the timer is on, and the radio remains keyed for a longer duration than the **TOT** value, the transmitter is automatically unkeyed. When this happens, the radio must be commanded back to an unkeyed state before a new keying command is accepted.

By default the timer is **ON** and set to 30 seconds.

TX [xxx.xxx]

This command sets or displays the radio's transmit frequency in MHz. The frequency must be an integer multiple of the step size and must be in the valid range. If the entered frequency is invalid, the HHT displays the message **INCORRECT ENTRY**.

There is no factory default. **TX** is factory set to customer order.

It was unclear from the markup whether there should be something or nothing in the second paragraph under TX.

6.0 TROUBLESHOOTING

Successful troubleshooting of the radio system is not difficult, but it requires a logical approach. It is best to begin troubleshooting at the master station, as the rest of the system depends on the master for polling commands. If the master station has problems, the operation of the entire network can be compromised.

It is good practice to start by checking the simple things. For proper operation, all radios in the network must meet these basic requirements:

- Adequate and stable primary power. The radio contains an internal self-resetting fuse (4A). Remove and re-apply primary power to reset.
- Secure connections (RF, data, and power)
- An efficient and properly aligned antenna system with a good received signal strength (at least -90 dBm). It is possible for a system to operate with weaker signals, but reliability will be degraded.
- Proper programming of the transceiver's operating parameters (see [Section 5.0, TRANSCIVER PROGRAMMING](#)).
- The correct interface between the transceiver and the connected data equipment (correct cable wiring, proper data format, timing, etc.)

6.1 LED Indicators

The LED status indicators are an important troubleshooting tool and should be checked whenever a problem is suspected. [Table 5 on page 14](#) describes the function of each status LED.

6.2 Event Codes

When an alarm condition exists, the transceiver creates a code that can be read on an HHT connected to the DATA INTERFACE port. These codes can be very helpful in resolving many system difficulties. Refer to [Table 8](#) for a definition of the event codes.

Checking for Alarms—*STAT* command

To check for alarms, enter **STAT** on the HHT. If no alarms exist, the message **NO ALARMS PRESENT** appears at the top of the display ([Figure 10](#)).

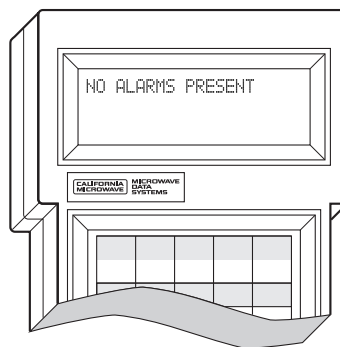

Figure 10. HHT Display in Response to STAT Command

If an alarm does exist, the **STAT** command displays a two-digit alarm code (00–31) and the event is identified as a Major or Minor Alarm. A brief description of the alarm is also given.

If more than one alarm exists, the word **MORE** appears at the bottom of the screen. To view additional alarms, press **[ENTER]**.

Major Alarms vs. Minor Alarms

Major Alarms—report serious conditions that generally indicate a hardware failure, or other abnormal conditions that will prevent (or seriously degrade) further operation of the transceiver. Major alarms generally indicate the need for factory repair. Contact MDS for further assistance.

Minor Alarms—report conditions that, under most circumstances will not prevent transceiver operation. These include out-of-tolerance conditions, baud rate mismatches, etc. The cause of these alarms should be investigated and corrected to prevent eventual system failure.

Event Code Definitions

Table 8 contains a listing of all event codes that may be reported by the transceiver.

Table 8. Event Codes

Event Code	Hex Value	Event Class	Description	STATUS Message
00	0000 0000	--	No alarms present.	NO ALARMS PRESENT
1–3	--	--	Not used.	--
04	0800 0000	Major	One or both of the internal programmable synthesizer loops is reporting an out-of-lock condition.	Synthesizer Out-of-Lock
5–7	--	--	Not used.	--
08	0080 0000	Major	The system is reporting that it has not been calibrated. Factory calibration is required for proper radio operation.	Radio Not Calibrated

Table 8. Event Codes (Continued)

Event Code	Hex Value	Event Class	Description	STATUS Message
09	--	--	Not used.	--
10	0020 0000	Major	The internal microcontroller was unable to properly program the system to the appropriate EEPROM defaults. A hardware problem may exist.	EEPROM Write Failure
11	--	--	Not used.	--
12	0008 0000	Major	Receiver time-out. No data received within the specified receiver time-out time.	Receiver time-out
13	0004 0000	Major	Transmitter time-out. The radio was keyed for a duration exceeding the time-out timer setting. (This alarm clears the next time the radio keys.)	Transmitter time-out
14–16	--	--	Not used.	--
17	0000 4000	Minor	A data parity fault has been detected on the DATA INTERFACE connector. This usually indicates a parity setting mismatch between the radio and the RTU.	Data Parity Error
18	0000 2000	Minor	A data framing error has been detected on the DATA INTERFACE connector. This may indicate a baud rate mismatch between the radio and the RTU.	Data Framing Error
19–30	--	--	Not used.	--

7.0 TECHNICAL REFERENCE

7.1 OEM-L/ss Transceiver Specifications

This section conforms with the specs literature Kevin sent me. Is there anything to add for this manual? ---Van

MODELS

MDS OEM-L2:	Licensed 220 MHz Transceiver
MDS OEM-L4:	Licensed 400 MHz Transceiver
MDS OEM-L9:	Licensed 900 MHz Transceiver
MDS OEM-SS9:	Frequency Hopping Spread Spectrum 900 MHz Transceiver

ENVIRONMENTAL

Temperature Range:	-30 to 60 degrees C
Humidity:	95% at 40 degrees C
Board Dimensions:	0.65" H x 4.60" W x 4.25" D 2 cm H x 11.7 cm W x 10.7 cm D
Weight:	0.2 pounds 0.09 kilograms
RF Connector:	BNC

TRANSMITTER

Power Output:	2 watts (+33 dBm) [1 watt (+30 dBm) for FHSS version]
Output Impedance:	50 Ω
Frequency Stability:	1.5 ppm
Transmitter Duty Cycle:	50%

RECEIVER

Type:	Double conversion superheterodyne
Sensitivity:	-108 dBm @ 1 x 10 ⁻⁶ BER
Adjacent Channel Performance:	60 dB EIA

DATA CHARACTERISTICS

Throughput:	9600 bps
Port Speed:	1200, 2400, 4800, 9600, 19200 bps programmable
Parity:	7/8 bit with or without Parity ASYNC
Modem:	Digital CPFSK

DIAGNOSTICS

Self Test:	Yes
Local RS-232 RSSI and Setup:	Yes
4 LED Display:	RS, TX, CD, and PWR

PRIMARY POWER

Voltage:	10 to 30 Vdc
TX Supply Current:	1.5 amps max

The specs literature Kevin sent me does not include 19200 bps, though it is in the specs document I was given. Has this changed? ---Van

Please verify primary power specs.

RX Supply Current:	<i>Operation</i> —< 60 mA (nominal) <i>Standby</i> —powered off (recovery time to receive ≤ 75 ms)
Fuse:	4 amp polyfuse, self-resetting, internal (remove preimary power to reset)
Reverse Polarity Protection:	Diode across primary input

7.2 Bench Testing Setup

Figure 11 shows a sample test setup that can be used to verify the basic operation of transceivers in a shop setting. The test can be performed with any number of remote radios by using a power divider with the required number of output connections.

The RTU simulator shown in the test setup (MDS Part No. 03-2512A01) is a microcontroller that emulates a remote terminal unit operating at 1200, 2400, 4800, or 9600 bps. Custom software is supplied with the RTU simulator that allows continuous polling of remote radios using an IBM-compatible personal computer. The software reports the number of polls sent, polls received, and the number of errors detected.

NOTE: It is very important to use attenuation between all units in the test setup. The amount of attenuation required will depend on the number of units being tested and the desired signal strength (RSSI) at each transceiver during the test. In no case should a signal greater than -50 dBm be applied to any transceiver in the test setup.

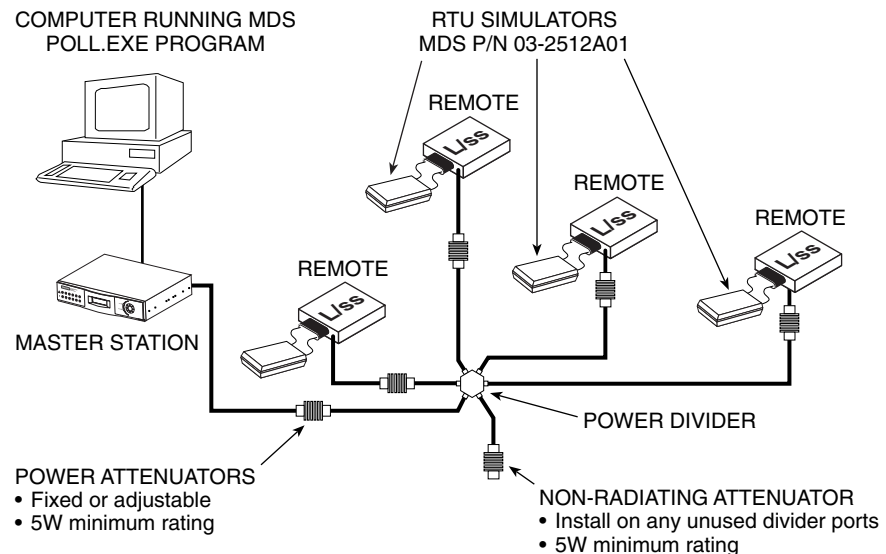

Figure 11. Typical setup for bench testing of radios

7.3 Helical Filter Adjustment

If the operating frequency of the radio is changed significantly, the helical filters should be adjusted for maximum received signal strength (RSSI). To adjust the filters, proceed as follows:

1. For enclosed units, remove the top cover from the transceiver by loosening the four screws and lifting straight up.
2. Locate the helical filters on the PC board. See [Figure 12](#).
3. Apply a steady signal to the radio at the programmed receive frequency (–80 dBm level recommended; no stronger than –60 dBm). This can be done with a signal generator or an over-the-air signal.
4. Measure the radio's RSSI using one of the following methods:
 - With an HHT (See [Section 5.0, TRANSCIEVER PROGRAMMING](#) on page 14).
 - With MDS Radio Configuration Software (See [Section 7.4, Upgrading the Radio's Software](#) on page 31).
 - With a voltmeter connected to Pin 21 of the DATA INTERFACE connector (See [Section 4.2, RSSI Measurement](#) on page 16).
5. With a non-metallic adjustment tool, adjust each section of the helical filter for maximum RSSI. Re-install the cover to the transceiver.

I am sure this figure needs changing. Can I call the helical adjustments out from the front cover image? Or do you want a diagram? ---Van

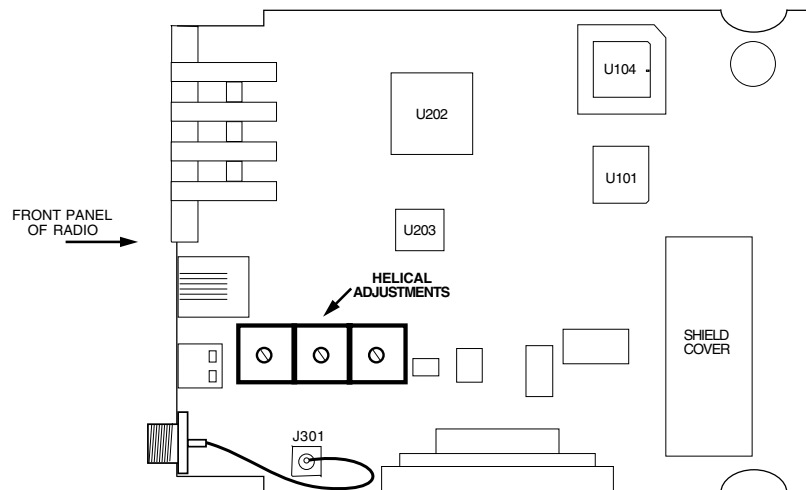

Figure 12. Helical Filter Location

7.4 Upgrading the Radio's Software

From time to time, new product features or software maintenance files may become available from MDS. This section describes the steps necessary to install new software into the transceiver using a PC connected to the radio's DATA INTERFACE port.

Upgrade software can be obtained in a number of ways. The MDS Web site at www.microwavedata.com contains an FTP area with software files for several radio models. You can browse the listings to see if there are files pertaining to your particular model. There is no charge for this service.

In addition, you can also contact MDS to request radio software. Software files can be sent to you via e-mail or on a 3.5" diskette. There may be a nominal charge for the software depending on the nature of the upgrade.

NOTE: Software upgrades are distributed as ASCII files with a ".S28" extension. These files use the Motorola S-record format.

Using the Radio Software Upgrade Diskette

A software upgrade diskette may be purchased from MDS to add new product features to the radio. The upgrade kit includes a diskette (MDS P/N 06-3501A01) with the most current radio software and an instruction booklet. Contact MDS for ordering information. When calling, please have the serial number(s) available for the radio(s) that you wish to upgrade.

The upgrade software can be run on an IBM-compatible computer connected to the radio's DATA INTERFACE port via a DB-9 to DB-25 adapter (MDS P/N ??-????A??). If desired, an adapter cable may be constructed from scratch using the information shown in [Figure 13](#).

Please verify the diagram. ---Van

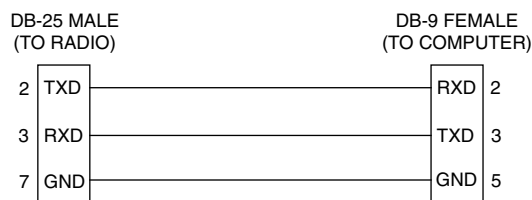

Figure 13. DB-25 to DB-9 Adapter Cable

To initiate the upgrade, insert the upgrade diskette in Drive A:. Set the working directory to **A:** (example: from a DOS prompt type **A:**). Next, type **UPGRADE** and press the **ENTER** key. (If you have the radio connected via the Com2 serial port, type **UPGRADE-2** instead.) The upgrade software will normally run automatically without any further prompts.

The radio's PWR LED will flash rapidly to confirm that a download is in process. The download takes about two minutes.

NOTE: If a software download fails, the radio is left unprogrammed and inoperative. This is indicated by the PWR LED flashing slowly (1 second on, 1 second off). This condition is only likely if a power failure occurred to the computer or radio during the downloading process. The download can be attempted again when the fault has been corrected.

Using Radio Configuration Software

If you already have software that you wish to download into the transceiver, Radio Configuration Software (MDS P/N 03-3156A01) may be used to perform the installation. To use this method, proceed as follows:

Connect a PC to the radio's DATA INTERFACE port via a DB-9 to DB-25 adapter (MDS P/N ??-????A??). If desired, an adapter cable may be constructed from scratch using the information shown in [Figure 13](#).

Run the Radio Configuration software. Under the **SYSTEM** menu, select **RADIO SOFTWARE UPGRADE**. Follow the prompts and online instructions to locate the desired software and complete the upgrade.

The radio's PWR LED will flash rapidly to confirm that a download is in process. The download takes about two minutes.

NOTE: If a software download fails, the radio is left unprogrammed and inoperative. This is indicated by the PWR LED flashing slowly (1 second on, 1 second off). This condition is only likely if a power failure occurred to the computer or radio during the downloading process. The download can be attempted again when the fault has been corrected.

INDEX

A

ACCESS DENIED error message 18

Accessories 5

Accessory Power pinout (Pin 18) 13

Alarms

alarm code definitions 26

major vs. minor 26

pinout (Pin 25) 13

using STAT command to display 24

AMASK command 19

Antenna

installation 8

RSSI command used to refine heading 14

system gain, defined 5

Yagi, illustrated 11

Antennas 10–11, ??–11

Applications 2

Multiple Address Systems (MAS) 2

point-to-multipoint system 2

point-to-point system 3

Auto-Open, pinout (Pin 23) 13

B

BAUD command 20

Bench testing (radio performance), 29

Bit, defined 5

Bits-per-second. See BPS

BPS (bits-per-second), defined 5

Byte, defined 5

C

Cable, loss due to length of coaxial 11

COMMAND FAILED error message 17

Command summary, table 18

Commands

AMASK (set/display alarm triggers) 19

BAUD (set/display rate, encoding) 20

CTS (set/display CTS line response timer) 20

DEVICE (set/display radio behavior) 21

DKEY (deactivate transmitter after KEY command) 21

entering on Hand-Held Terminal (HHT) 17

Hand-Held Terminal (HHT) 17

INIT (reinitialize radio to factory defaults) 22

KEY (activate transmitter) 22

OWM (set/display owner's message) 22

OWN (set/display owner's name) 22

PWR (set/display RF forward output power) 23

RSSI (display RSSI) 23

RX (set/display receive frequency) 23

RXTOT (set/display receive time-out timer value) 23

SER (display radio serial number) 24

SREV (display software revision level) 24

STAT (display current alarm status) 24

TOT (set/display time-out value and timer status) 24

TX (set/display transmit frequency) 24

Connections

for typical systems 2

Conversions, dBm-Watts-Volts 33

CTS command 20

CTS pinout (Pin 5) 12

D

Data interface

connector pinouts 12

installing connection 12

dB. See Decibel 6

dBi, defined 5

dBm, defined 6

DCD

LED 14

pinout (Pin 8) 12

DCE (Data Circuit-terminating Equipment), defined 6

Decibel (dB), defined 6

Description, product 1

Detailed 19

DEVICE command 21

Diagnostic Channel Enable, pinout (Pin 23) 13

Diagnostics

interface specifications 28

PC software used for 31

Differences between models 1

Display

alarm status (STAT command) 24

alarm triggers (AMASK command) 19

baud rate and encoding (BAUD command) 20

CTS line response timer (CTS command) 20

owner's message (OWM command) 22

owner's name (OWN command) 22

radio behavior (DEVICE command) 21

radio serial number (SER command) 24

receive frequency (RX command) 23

receive time-out timer value (RXTOT command) 23

RF forward output power (PWR command) 23

RSSI (RSSI command) 23

software revision level (SREV command) 24

time-out value and timer status (TOT command) 24

transmit frequency (TX command) 24

DKEY command 21

Downloading new software 31
DSR pinout (Pin 6) 12
DTE (Data Terminal Equipment), defined 6

E

EEPROM FAILURE error message 18
Enable/disable
 diagnostic channel, pinout (Pin 23) 13
Environment specifications 28
Equalization, defined 6
Error messages 17
 access denied 18
 command failed 17
 EEPROM failure 18
 incorrect entry 17
 not available 17
 not programmed 17
 text too long 17
 unknown command 17

F

Fade margin, defined 6
Feedlines 11
Filter, helical, adjustment 30
Frame, defined 6
Frequency
 adjusting helical filter when changed 30
 setting. See TX and RX commands

G

Glossary 5
Ground
 protective (Pin 1) 12
 signal (Pin 7) 12

H

Half-duplex 3
 switched carrier operation 4
Hand-Held Terminal (HHT) 5
 connected to transceiver, illustrated 15
 connection and startup 15
 display in response to STAT command, illustrated 26
 entering commands 17
 error messages displayed on 17
 keyboard commands 17
 operational settings, table 16
 reinitialization display, illustrated 16
 reinitializing 16
Hardware flow control, defined 6
Helical filter
 adjusting 30
 illustration 30
Host computer, defined 6

I

Illustrations

antenna, Yagi 11
DB-25 to DB-9 adapter cable 31
Hand-Held Terminal (HHT) connected to transceiver 15
Hand-Held Terminal (HHT) reinitialization display 16
Hand-Held Terminal display in response to STAT command 26
helical filter locations 30
MAS network 3
MDS 2710A/D model number codes 4
point-to-point link 3
remote station arrangement 8
transceiver connectors & indicators 2
transceiver mounting dimensions 10

INCORRECT ENTRY error message 17

INIT command 22

Installation 8–13

 antenna 8
 configuring transceiver 9
 DATA INTERFACE connection 9
 data interface connections 12
 power 8
 power connection 11
 quick start instructions. See inside front cover steps 8

K

KEY command 22

Keying

 continuously keyed versus switched carrier operation 4
 on data (DKEY command) 21
 switched carrier, defined 4

L

Latency, defined 6

LEDs

 DCD 14
 indicators, described 14
 PWR 14
 RXD 14
 RXD, Pin 3 12
 status indicators, illustrated 14
 TXD 14
 TXD, Pin 2 12

Loss. See Signal

M

MAS (Multiple Address System) 2

 defined 6
 illustration 3

Master Station

 defined 6
 keying behavior 4

MDS. See **Microwave Data Systems** 7
Microwave Data Systems, contacting 7
Model number codes 4
 MDS 2710A/D, illustrated 4

N

NOT AVAILABLE error message 17
NOT PROGRAMMED error message 17

O

Operation 13–??
 environment, specifications for 28
Output, 5.8 Vdc regulated, pinout (Pin 19) 13
OWM command 22
OWN command 22
Owner's message, set/display. See **OWM command**
Owner's name, set/display. See **OWN command**

P

Packaging for shipment. See **inside rear cover**
Payload data (defined) 7
Performance
 testing, 29
Pinouts on data interface 12
PLC (Programmable Logic Controller), defined 7
Point-to-multipoint
 defined 7
 system 2
Point-to-point
 link, illustrated 3
 system 3
Poll, defined 7
Power
 connection 11
 installing 8
 LED status indicator (PWR LED) 14
 RF, chart for converting dBm-Watts-Volts 33
Power attenuators, use of in testing 29
Procedures
 checking for alarms (STAT command) 25
 connecting Hand-Held Terminal (HHT) 15
 downloading new software 31
 entering commands using the Hand-Held Terminal (HHT) 17
 helical filter adjustment 30
 installation 8
 operation 13
 performance optimization 14
 reading LED status indicators 14
 resetting Hand-Held Terminal (HHT) 16
 troubleshooting 25–??
Product
 accessories 5
 description 1
 display radio serial number (SER command) 24
 model number codes 4

 returning for service. See **inside rear cover**
Programming, transceiver 14–18
PWR
 command 23
 LED 14

Q

Quick start instructions. See **inside front cover**

R

Radio
 Configuration Software 5, 31
 serial number, displaying (SER command) 24
Receive Audio Output pinout (Pin 11) 13
Received signal strength indication See **RSSI** 7
Receiver
 specifications 28
Redundant operation, defined 7
Remote
 Station, defined 7
 Station, illustrated 8
Resetting
 Hand-Held Terminal (HHT) (SHIFT,CTRL,SPACE keys) 16
 transceiver (INIT command) 22
Revision level
 display software (SREV command) 24
RMA number (returning product for service). See **inside rear cover**
RSSI
 adjusting helical filter for increased signal strength 30
 command 23
 command, used to refine antenna heading 14
 defined 7
RTS pinout (Pin 4) 12
RTU (Remote Terminal Unit)
 defined 7
RTU simulator, 29
RX command 23
RXD LED
 description 14
 Pin 3 12
RXTOT command 23

S

SCADA (Supervisory Control And Data Acquisition), defined 7
SER command 24
Set
 alarm triggers (AMASK command) 19
 receive time-out timer value (RXTOT command) 23
Signal
 ground (Pin 7) 12
 loss due to coaxial cable length, table 11
Simplex 3
 single-frequency operation 4
 special case of switched carrier operation 4
Software

- diagnostics and control used from PC 31
- display revision level 24
- upgrades (.S28 files) 31
- upgrading 31
- used for diagnostics and programming 14

Specifications

- diagnostics interface 28
- environment 28
- receiver 28
- transceiver 28–29
- transmitter 28
- transmitter system 28

SREV command 24

STAT command 24

SWR (Standing Wave Ratio), defined 7

T

Tables

- accessories 5
- alarm code definitions 26
- command summary 18
- conversions, dBm-Watts-Volts 33
- data interface connector pinouts 12
- Hand-Held Terminal (HHT) operational settings 16
- LED status indicators 14
- length vs. loss in coaxial cables 11

Technical reference 28–33

Technical reference,

- bench test setup, 29

Testing. See bench testing

TEXT TOO LONG error message 17

Timer, set/display time-out value and status (TOT command) 24

TOT command 24

Transceiver

- applications 2
- configuring for operation 9
- connectors and indicators, illustrated 2
- diagnostics using PC software 31
- dimensions, mounting 10
- mounting 8
- mounting enclosed version 10
- mounting standalone board 9
- programming 14–18
- specifications 28–29
- upgrading software 31

Transmitter

- specifications 28
- system specifications 28

Troubleshooting 25–??

- connecting Hand-Held Terminal (HHT) for displaying alarm codes 15
- returning product for service. See inside rear cover
- STAT command (Status) 25
- using PC software for 31

TX command 24

TXD LED

- description 14
- Pin 2 12

U

UNKNOWN COMMAND error message 17

IN CASE OF DIFFICULTY...

MDS products are designed for long life and trouble-free operation. However, this equipment, as with all electronic equipment may have an occasional component failure. The following information will assist you in the event that servicing becomes necessary.

FACTORY TECHNICAL ASSISTANCE

Technical assistance for MDS products is available from our Customer Support Team during business hours (8:00 A.M.–5:30 P.M. Eastern Time). When calling, please give the complete model number of the radio, along with a description of the trouble symptom(s) that you are experiencing. In many cases, problems can be resolved over the telephone, without the need for returning the unit to the factory.

Please use the following telephone numbers for product assistance:

716-242-9600 (Phone)

716-242-9620 (FAX)

FACTORY REPAIRS

Component-level repair of radio equipment is *not* recommended in the field. Many components are installed using surface mount technology, which requires specialized training and equipment for proper servicing. For this reason, the equipment should be returned to the factory for any PC board repairs. The factory is best equipped to diagnose, repair and align your radio to its proper operating specifications.

If return of the equipment is necessary, you will be issued a Returned Material Authorization (RMA) number. The RMA number will help expedite the repair so that the equipment can be repaired and returned to you as quickly as possible. Please be sure to include the RMA number on the outside of the shipping box, and on any correspondence relating to the repair. *No equipment will be accepted for repair without an RMA number.*

A statement should accompany the radio describing, in detail, the trouble symptom(s), and a description of any associated equipment normally connected to the radio. It is also important to include the name and telephone number of a person in your organization who can be contacted if additional information is required.

The radio must be properly packed for return to the factory. The original shipping container and packaging materials should be used whenever possible. All factory returns should be addressed to:

Adaptive Broadband Corporation
Customer Service Department
(RMA No. XXXX)
175 Science Parkway
Rochester, NY 14620 USA

When repairs have been completed, the equipment will be returned to you by the same shipping method used to send it to the factory. Please specify if you wish to make different shipping arrangements.



ADAPTIVE BROADBAND™

175 Science Parkway, Rochester, New York 14620
General Business: +1 (716) 242-9600
FAX: +1 (716) 242-9620
World Wide Web: <http://www.mdsroc.com/>

