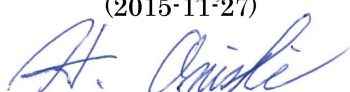

# TEST REPORT

Issued: November 27, 2015

Name and Address of the Customer:	KYOCERA Document Solutions Inc. 2-28, 1-Chome, Tamatsukuri, Chuo-ku, Osaka, 540-8585, Japan
Test Item:	RFID Module
Identification:	2RHA0943
Serial No.:	1, 2
FCC ID:	E522RHA0943
IC Certification Number:	1059B-2RHA0943
Sample No.:	1
Sample Receipt Date:	September 7, 2015
Test Specification:	47 CFR Part 15 Subpart C RSS-210 Issue 8, RSS-Gen Issue 4
Period of Testing:	September 7, 2015 - November 24, 2015
Test Result:	PASS

Representative Test Personnel:	 _____ (2015-11-27)	K. Miyaji (EMC Dept.) iNARTE : EMC-003627-NE
Reviewed by:	 _____ (2015-11-27)	H. Onishi (EMC Dept.) iNARTE : EMC-003318-NT

Other Aspects:	
Abbreviations:	PASS = passed FAIL = failed N/A = not applicable

Note:  
 This Test Report should not be reproduced except in full, without the written approval of Cosmos Corporation.  
 The test result of this Test Report is based on the tests made for sample provided, and it is not applicable to individual product identical to the sample or similar product.  
 The judgment of this test report validates the test item only specified in "4. Summary of Test Results".



Contents	Page
<b>1. General Information.....</b>	<b>3</b>
1.1 Test Methodology .....	3
1.2 Test Facility .....	3
1.3 Traceability .....	3
<b>2. Description of the Tested Sample .....</b>	<b>4</b>
2.1 Product Description .....	4
2.2 Antenna Description .....	4
2.3 EUT Description .....	4
<b>3. Test Condition (Manufacturer's Specification) .....</b>	<b>5</b>
3.1 Mode of Operation .....	5
3.2 Additional Equipment .....	5
3.3 Configuration .....	6
3.4 EUT Angle .....	8
<b>4. Summary of Test Results .....</b>	<b>9</b>
<b>5. Test Result .....</b>	<b>10</b>
5.1 AC Power Line Conducted Emission (15.207, RSS-Gen 8.8).....	10
5.1.1 Setting Remarks .....	10
5.1.2 Limit .....	10
5.1.3 Test Detail .....	11
5.2 Transmitter Spurious Emission (Radiated) (15.209, 15.225(d), RSS-Gen 8.9) .....	14
5.2.1 Setting Remarks .....	14
5.2.2 Limit .....	15
5.2.3 Test Detail .....	15
5.3 20 dB Bandwidth (15.215(c)) .....	19
5.3.1 Setting Remarks .....	19
5.3.2 Limit .....	19
5.3.3 Test Detail .....	19
5.4 Field Strength of Fundamental Emission (15.225(a) (b) (c) (d), RSS-210 A2.6) .....	21
5.4.1 Setting Remarks .....	21
5.4.2 Limit .....	21
5.4.3 Test Detail .....	22
5.5 Frequency Stability (15.225(e), RSS-210 A2.6).....	26
5.5.1 Setting Remarks .....	26
5.5.2 Limit .....	26
5.5.3 Test Detail .....	26
5.6 Occupied Bandwidth (RSS-Gen Annex A) .....	29
5.6.1 Setting Remarks .....	29
5.6.2 Test Detail .....	29
<b>6. List of Test and Measurement Instruments .....</b>	<b>31</b>
<b>7. Appendix.....</b>	<b>33</b>



## 1. General Information

### 1.1 Test Methodology

All measurement subject to the present test report is carried out according to the procedures in ANSI C63.10:2013.

### 1.2 Test Facility

The measurement was carried out at the following facility.

Cosmos Corporation EMC Lab. Oonoki  
3571-2 Oonoki, Watarai-cho, Watarai-gun, Mie-ken 516-2102, Japan

- Semi anechoic Chamber 3 m (COAC3M-01)
- Shielded Room (COSR-01)
- Measurement Room

Cosmos Corporation EMC Lab. Oonoki is accredited in accordance with the International Standard ISO/IEC 17025 by the following accreditation bodies and the test facility is registered by the following bodies.

Accreditation: A2LA Accredited Laboratory No. 2900.01  
VLAC Accredited Laboratory No. VLAC-039-2  
FCC Designation No. JP5182

Registration: Industry Canada Registration No. 3958B  
Nemko Laboratory Authorisation. No. ELA 621

### 1.3 Traceability

The calibration of measurement equipment used in the test subject to the present report is designed and operated to ensure that the measurement is traceable to national standards of measurement or equivalent abroad.



## 2. Description of the Tested Sample

### 2.1 Product Description

Manufacturer	KYOCERA Document Solutions Inc.
Model (referred to as the EUT)	2RHA0943
Hardware Version	A0943B
Software Version	S2RH_1000.X26.001.bin
Type of the Equipment	<input type="checkbox"/> Stand-alone <input type="checkbox"/> Combined Equipment <input checked="" type="checkbox"/> Plug-in Radio Device <input type="checkbox"/> Other ( )
Transmitter Type	<input type="checkbox"/> WLAN <input type="checkbox"/> Bluetooth ( ) <input type="checkbox"/> ZigBee <input checked="" type="checkbox"/> RFID <input type="checkbox"/> Other ( )
Nominal Voltage	DC 3.3/5 V
Type of Modulation	ASK
Emission Designator	6K93K1D
Antenna Type	<input checked="" type="checkbox"/> Integral Antenna <input type="checkbox"/> Dedicated External Antenna
Operating Frequency	13.56 MHz
Type of Power Source	<input type="checkbox"/> AC Mains <input type="checkbox"/> Dedicated AC Adaptor <input checked="" type="checkbox"/> DC Voltage <input type="checkbox"/> Battery
Type of Battery (if applicable)	N/A
Thermal Limitation	-20°C to 50°C

### 2.2 Antenna Description

Model	Gain	Antenna Type	Remarks
Un-specified *	-53 dBi	Loop antenna	---

Note:

\*: The antenna does not have model name, because the antenna is part of RF Module PCB.

### 2.3 EUT Description

Equipment under test is as follow:

Instrument	Model	Serial No.	Rating
RFID Module (EUT1)	2RHA0943	1	DC 3.3/5 V
RFID Module (EUT2)	2RHA0943	2	DC 3.3/5 V



### 3. Test Condition (Manufacturer's Specification)

#### 3.1 Mode of Operation

Mode of operation: RFID Operating

Note:

The EUT makes communication emission with the maximum RF power by a special test program. "Special test program" is that duty cycle is set 100% for a test, although it is less than 10% in normal operation.

The module has 4 antennas. This module outputs the power by switching 4 antennas.

However, we measured the only 1 antenna which was selected by manufacturer as worst case.

The test of Field Strength of Fundamental Emission was performed under the following condition:

Voltage: DC 3.3/5 V  $\pm$ 15%

The test of Frequency Stability was performed under the following condition:

Temperature: -20°C to +50°C

Voltage: DC 3.3/5 V  $\pm$ 15%

#### 3.2 Additional Equipment

The equipment was tested together with additional peripherals.

The following peripherals were used during the tests:

Instrument	Model	Serial No.	Manufacturer
Multi-Function Printer	TASKalfa 4011i	Z955100005	KYOCERA Document Solutions
Personal Computer	PP17L	CN-0N8719-48643-57F-1500	DELL
AC Adapter	HP-OQ065B83	CN-0N2765-47890-47D-8266	DELL
USB Mouse	M-BJ58	LNA30910367	Logitech
Jig	Un-specified	Un-specified	Un-specified

### 3.3 Configuration

	Instrument	Model	Cable	Length	Shield
<b>A</b>	EUT1 (RFID Module)	2RHA0943 (S/N:1)	<b>a</b> AC Power Cord	2.5 m	×
			<b>b</b> AC Power Cord	2.1 m	×
<b>B</b>	EUT2 (RFID Module)	2RHA0943 (S/N:1)	<b>c</b> AC Power Cord	2.1 m	×
			<b>d</b> AC Power Cord	0.9 m	×
<b>C</b>	Multi-Function Printer	TASKalfa 4011i	<b>e</b> DC Power Cord	1.9 m	○
<b>D</b>	Personal Computer	PP17L	<b>f</b> LAN Cable	2.0 m	×
<b>E</b>	AC Adapter	HP-OQ065B83	<b>g</b> USB Cable	2.0 m	○
<b>F</b>	USB Mouse	M-BJ58	<b>h</b> USB Cable	1.8 m	○
<b>G</b>	Jig	Un-specified	<b>i</b> USB Mouse Cable	1.8 m	○
			<b>j</b> Jig Cable	0.5 m	×

#### AC Power Line Conducted Emission

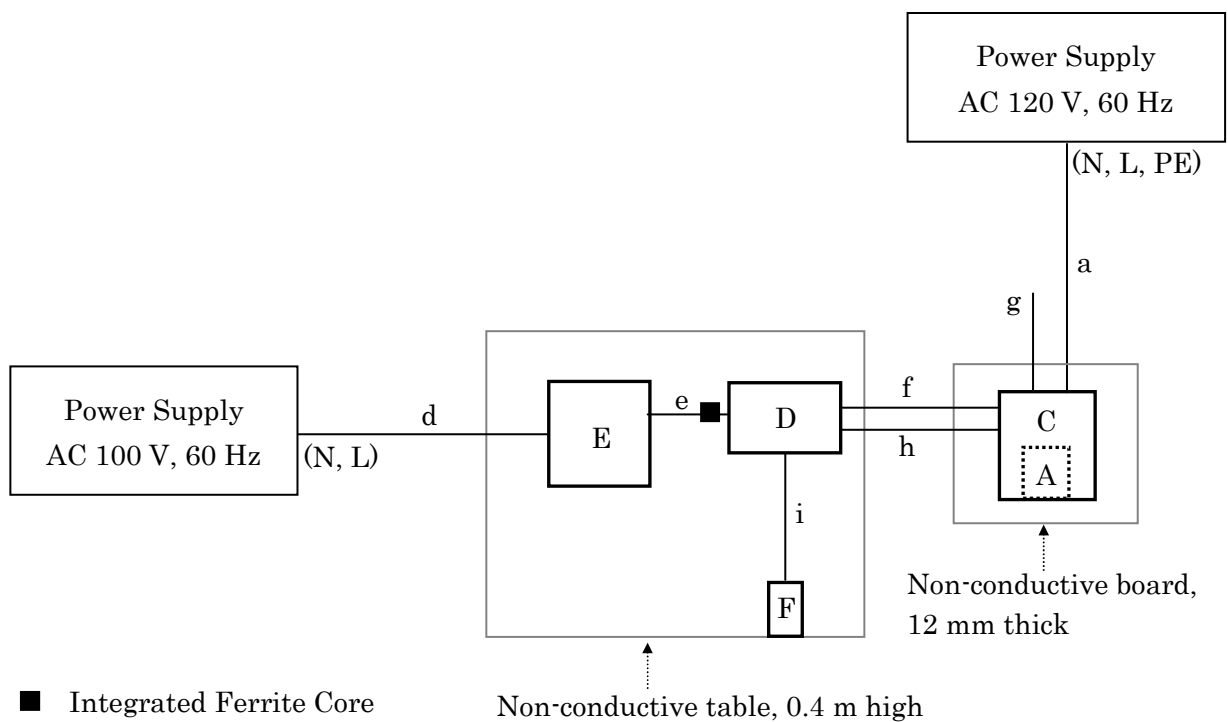

#### Excess cable arrangement

##### AC Power Line Conducted Emission

Symbol	Length	Position	Setting
a	0.4 m	Center	Bundle
e	0.35 m	Center	Bundle
f, h, i	0.3 m	Center	Bundle
g	0.35 m	End	Bundle and Hung

### 3.3 Configuration (Continued)

**Transmitter Spurious Emission (Radiated)**  
**Field Strength of Fundamental Emission (normal voltage only)**

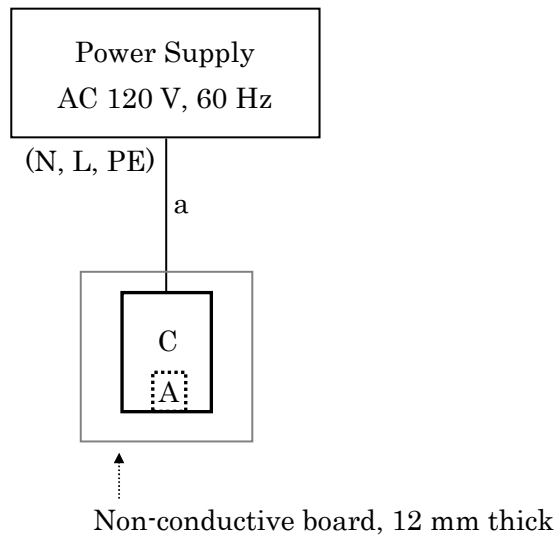

**20 dB Bandwidth / Frequency Stability / Occupied Bandwidth**

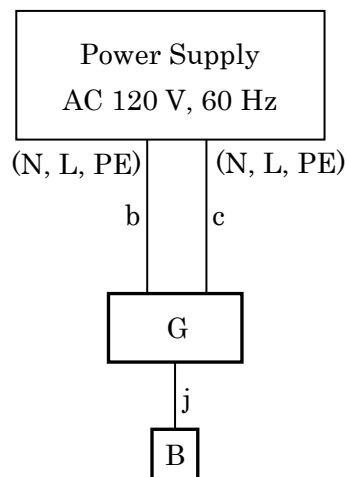

### 3.3 Configuration (Continued)

Field Strength of Fundamental Emission (normal and  $\pm 15\%$  voltage)

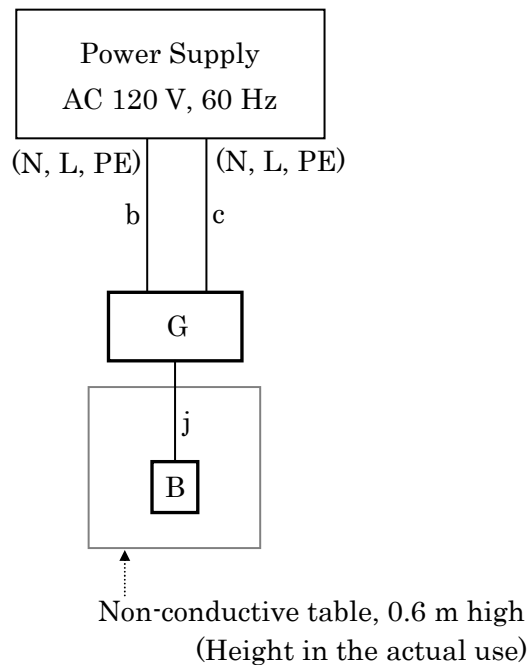

### 3.4 EUT Angle

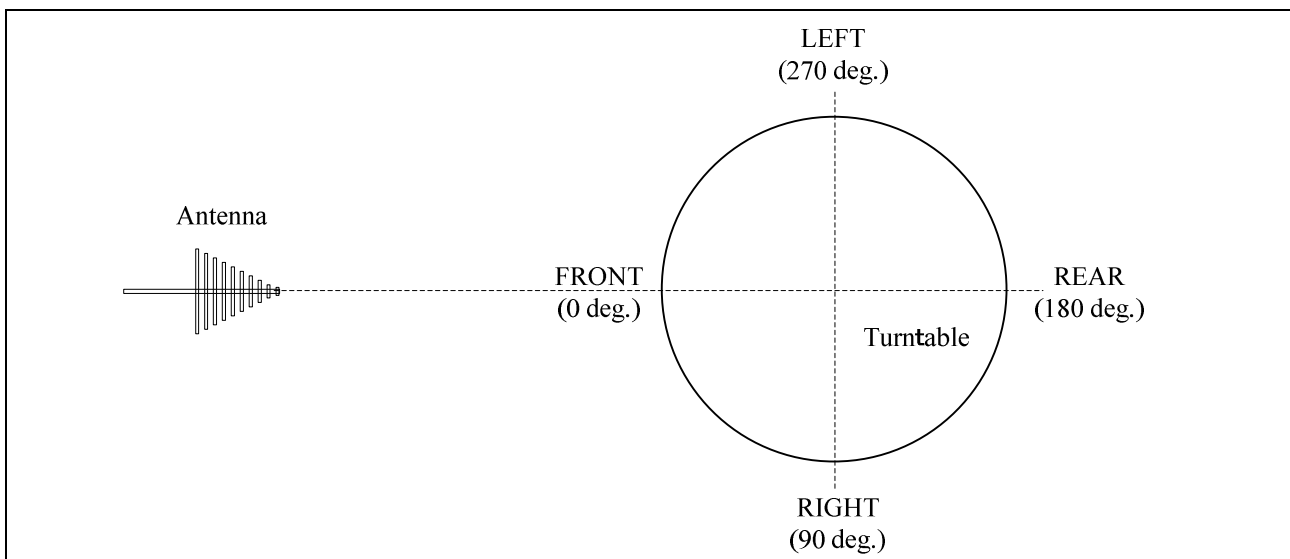





#### 4. Summary of Test Results

These test results are the test results of the condition specified with “3. Test Condition”.

FCC Section	IC Section	Test Item	FCC Result	IC Result
15.207	RSS-Gen 8.8	AC Power Line Conducted Emission	PASS	PASS
15.209, 15.225(d)	RSS-Gen 8.9	Transmitter Spurious Emission (Radiated)	PASS	PASS
15.215(c)	---	20 dB Bandwidth	PASS	---
15.225 (a) (b) (c) (d)	RSS-210 A2.6	Field Strength of Fundamental Emission	PASS	PASS
15.225(e)	RSS-210 A2.6	Frequency Stability	PASS	PASS
---	RSS-Gen Annex A	Occupied Bandwidth	---	PASS
---	RSS-Gen 7.1	Receiver Spurious Emission (Radiated)	---	N/A *

Note:

\*: This item does not apply because this device receives some data only while the radio waves are transmitted.



## 5. Test Result

### 5.1 AC Power Line Conducted Emission (15.207, RSS-Gen 8.8)

Result: PASS

#### 5.1.1 Setting Remarks

The conducted disturbance voltage of AC power line in the frequency range from 150 kHz to 30 MHz was measured in accordance with ANSI C63.10:2013.

The test setup was made in accordance with ANSI C63.10:2013 in a shielded room. The non-conductive board, 12 mm thick, was placed on the reference ground plane, and the EUT was put on the non-conductive board. The used Line Impedance Stabilizing Network (LISN) has a rated impedance of 50  $\Omega$ /50  $\mu$ H as specified in CISPR16-1-2. The test receiver with Quasi Peak and Average detector is in accordance with CISPR 16-1-1.

The conducted emission level is calculated by adding Cable Attenuation Factor and Insertion Loss of LISN.

Activate the EUT System and run the software prepared for the test.

Setting Condition of Test receiver

Frequency range	Detector	RBW
150 kHz to 30 MHz	Quasi Peak	9 kHz
	Average	9 kHz

#### 5.1.2 Limit

Frequency range	Conducted Limit [dB $\mu$ V]	
	Quasi Peak	Average
150 kHz to 500 kHz	66 to 56 *	56 to 46 *
500 kHz to 5 MHz	56	46
5 MHz to 30 MHz	60	50

Note:

\*: Decrease with the logarithm of the frequency.



### 5.1.3 Test Detail

Uncertainty of measurement result :  $\pm 3.45$  dB  
Date of testing : September 8, 2015  
Room temperature :  $23^{\circ}\text{C}$   
Relative humidity : 45%

#### Calculation

Result = Reading + c.f  
=  $36.2 + 10.4$   
= 46.6

Margin = Limit - Result  
=  $65.4 - 46.6$   
= 18.8

#### Note:

c.f (Correction Factor) = Cable Attenuation Factor + LISN Factor



5.1.3 Test Detail (Continued)

Test Data

\*\*\*\*\* Cosmos Corporation \*\*\*\*\*  
 <<Conducted Emission EP5/CE Ver 5.3.20>>

8 September, 2015 14:22  
 131221E FCC CE 03. dat

Limit : FCC 15.207  
 Model : 2RHA0943 / TASKalfa 4011i  
 Serial : 1 / Z955100005  
 Operater : K. Miyaji  
 Power : DC 3.3V, 5V / AC 120V, 60Hz  
 Temp., Humi. : 23 deg., 45%  
 Mode : RFID  
 Remark :  
 Remark :  
 Remark : RBW:9kHz

\*\*\*\*\*  
 Final Result

--- L1 Phase ---

No.	Frequency	Reading QP	Reading AV	c. f	Result QP	Result AV	Limit QP	Limit AV	Margin QP	Margin AV
	[MHz]	[dB(μV)]	[dB(μV)]	[dB]	[dB(μV)]	[dB(μV)]	[dB(μV)]	[dB(μV)]	[dB]	[dB]
1	0.1621	36.2	27.3	10.4	46.6	37.7	65.4	55.4	18.8	17.7
2	0.2434	32.1	23.5	10.3	42.4	33.8	62.0	52.0	19.6	18.2
3	0.667	25.7	17.4	10.3	36.0	27.7	56.0	46.0	20.0	18.3
4	4.377	15.2	8.3	10.8	26.0	19.1	56.0	46.0	30.0	26.9
5	13.560	21.1	17.2	11.8	32.9	29.0	60.0	50.0	27.1	21.0
6	20.720	18.6	10.5	12.0	30.6	22.5	60.0	50.0	29.4	27.5

--- L2 Phase ---

No.	Frequency	Reading QP	Reading AV	c. f	Result QP	Result AV	Limit QP	Limit AV	Margin QP	Margin AV
	[MHz]	[dB(μV)]	[dB(μV)]	[dB]	[dB(μV)]	[dB(μV)]	[dB(μV)]	[dB(μV)]	[dB]	[dB]
1	0.1614	39.4	28.2	10.5	49.9	38.7	65.4	55.4	15.5	16.7
2	0.2432	31.9	22.2	10.3	42.2	32.5	62.0	52.0	19.8	19.5
3	0.6665	26.3	17.6	10.3	36.6	27.9	56.0	46.0	19.4	18.1
4	3.633	15.1	8.3	10.7	25.8	19.0	56.0	46.0	30.2	27.0
5	13.560	18.4	15.9	11.7	30.1	27.6	60.0	50.0	29.9	22.4
6	21.117	19.6	11.3	11.9	31.5	23.2	60.0	50.0	28.5	26.8



### 5.1.3 Test Detail (Continued)

#### Test Data

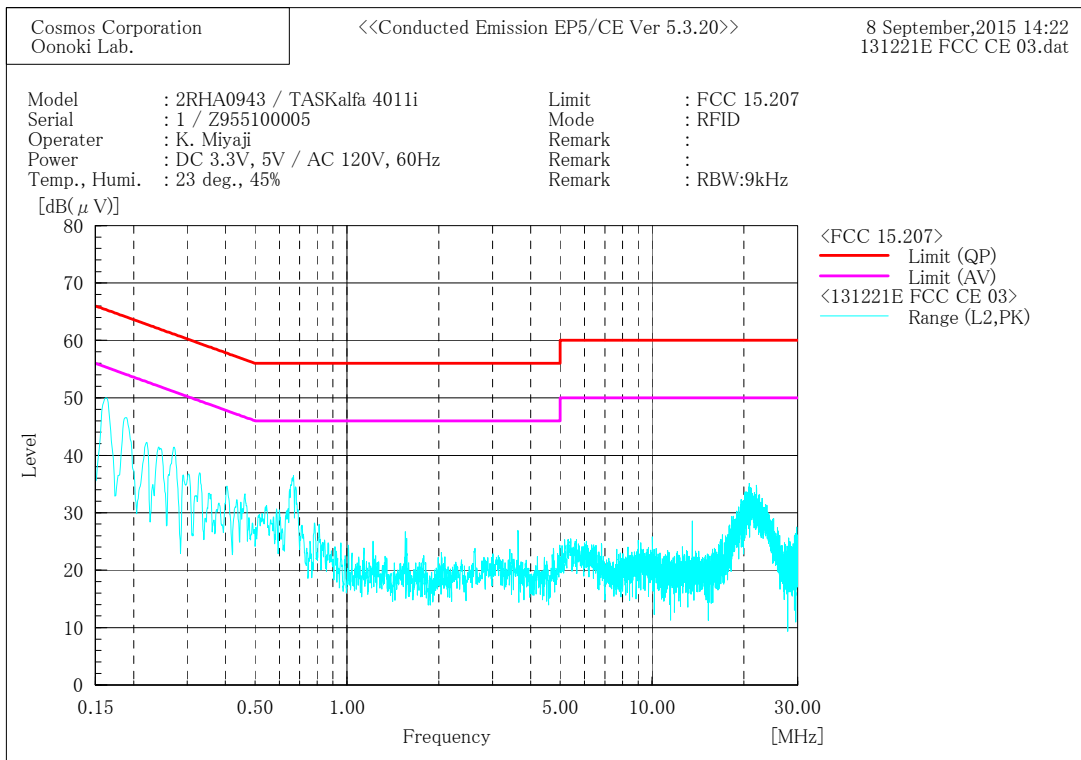
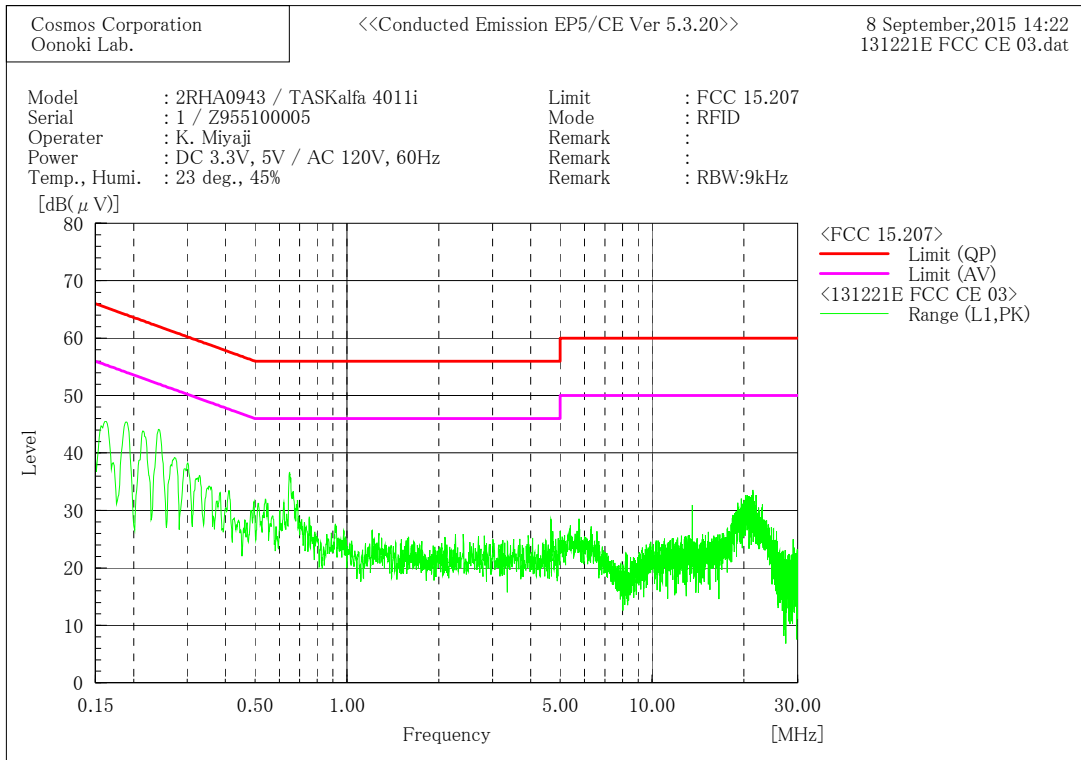



## 5.2 Transmitter Spurious Emission (Radiated) (15.209, 15.225(d), RSS-Gen 8.9)

Result: **PASS**

### 5.2.1 Setting Remarks

In the frequency range from 9 kHz to 1 GHz (over 10th harmonics), the electric field strength was measured in accordance with ANSI C63.10:2013.

The test setup was made in accordance with ANSI C63.10:2013 in a semi-anechoic chamber.

The non-conductive board, 12 mm thick, was placed on the turntable, and the EUT was put on the non-conductive board. The EUT was measured at 1 m to 4 m height of the antenna above 30 MHz.

The turntable was fully rotated. The highest radiation from the equipment was recorded. The measurement above 30 MHz was carried out with both horizontal and vertical antenna

polarization. The test receiver with Quasi Peak detector is in accordance with CISPR 16-1-1.

The measurement was carried out with the measuring distance of 3 m. Then the limit of 30 m distance below 30 MHz was converted to the limit of 3 m distance with the  $40\log(30\text{ m}/3\text{ m})$ .

Setting Condition of Test receiver

Frequency range	Detector	RBW
9 kHz to 90 kHz	Peak	200 Hz
	Average	200 Hz
90 kHz to 110 kHz	Quasi Peak	200 Hz
110 kHz to 150 kHz	Peak	200 Hz
	Average	200 Hz
150 kHz to 490 kHz	Peak	9 kHz
	Average	9 kHz
490 kHz to 30 MHz	Quasi Peak	9 kHz
30 MHz to 1 GHz	Quasi Peak	120 kHz



### 5.2.2 Limit

The emission limits shown in the following table are based on measurements employing a CISPR Quasi Peak detector except for the frequency bands 9 kHz to 90 kHz, 110 kHz to 490 kHz and above 1000 MHz. Radiated emission limits in these three bands are based on measurements employing an Average detector. The limit on Peak radio frequency emissions is 20 dB above the maximum permitted Average emission limit applicable to the equipment under test.

Frequency range	Field Strength (Distance)	
	[ $\mu$ V/m]	[dB $\mu$ V/m]
9 kHz to 490 kHz	2400/F (kHz) 266.6 to 4.89 (300 m)	128.5 to 93.8 (3 m)
490 kHz to 1.705 MHz	24000/F (kHz) 48.9 to 14.0 (30 m)	73.8 to 62.9 (3 m)
1.705 MHz to 30 MHz	30 (30 m)	69.5 (3 m)
30 MHz to 88 MHz	100 (3 m)	40.0 (3 m)
88 MHz to 216 MHz	150 (3 m)	43.5 (3 m)
216 MHz to 960 MHz	200 (3 m)	46.0 (3 m)
Above 960 MHz	500 (3 m)	53.9 (3 m)

### 5.2.3 Test Detail

Uncertainty of measurement result :  $\pm 5.08$  dB  
Date of testing : September 7, 2015  
Room temperature : 21 - 22°C  
Relative humidity : 41 - 45%

#### Calculation

$$\begin{aligned} \text{Result} &= \text{Reading} + \text{c.f} \\ &= 48.9 + 20.7 \\ &= 69.6 \end{aligned}$$

$$\begin{aligned} \text{Margin} &= \text{Limit} - \text{Result} \\ &= 132.7 - 69.6 \\ &= 63.1 \end{aligned}$$

Note:

[Below 30 MHz]

c.f (Correction Factor) = Cable Attenuation Factor + Antenna Factor

[Above 30 MHz]

c.f (Correction Factor) = Cable Attenuation Factor + Antenna Factor + Amplifier Gain



5.2.3 Test Detail (Continued)

<Below 30 MHz>  
 Worst Test Data (Antenna: 0°, Detector: Peak)

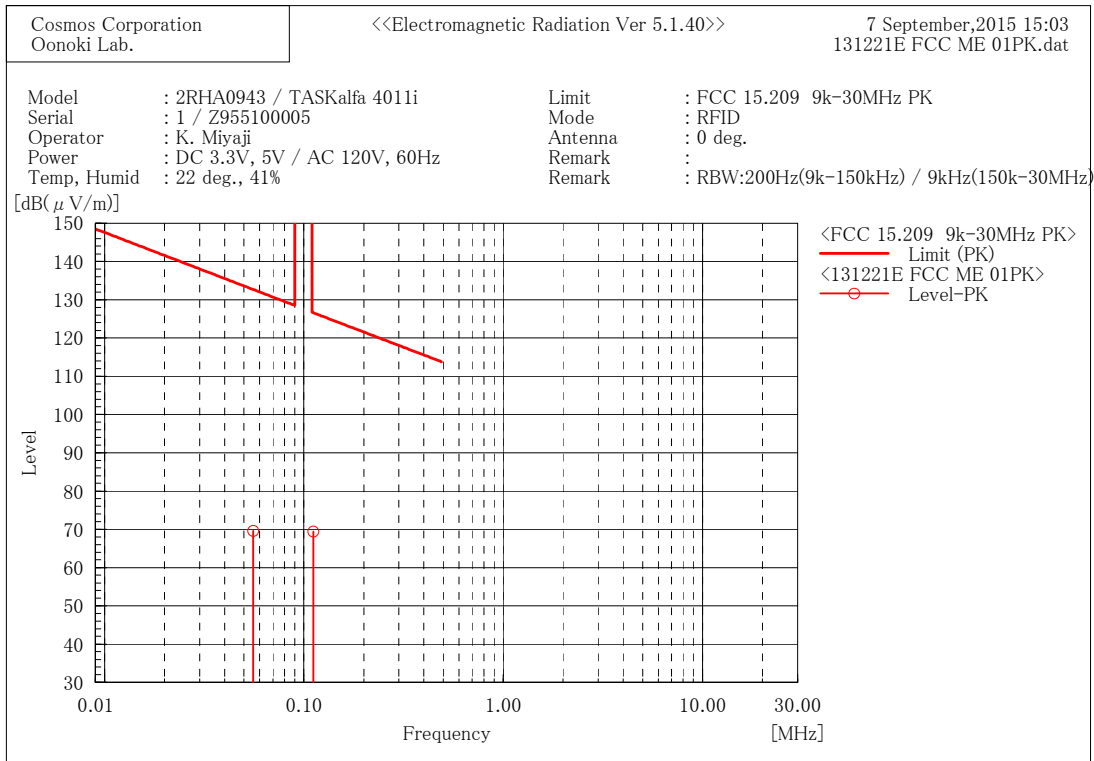

Final Result

No.	Frequency [MHz]	Reading [dB(μV)]	c. f [dB(1/m)]	Result [dB(μV/m)]	Limit [dB(μV/m)]	Margin [dB]	Angle [°]	Remark
1	0.0557	48.9	20.7	69.6	132.7	63.1	148.0	
2	0.1114	48.8	20.6	69.4	126.6	57.2	149.0	





5.2.3 Test Detail (Continued)

<Below 30 MHz>  
 Test Data (Antenna: 0°, Detector: Average)

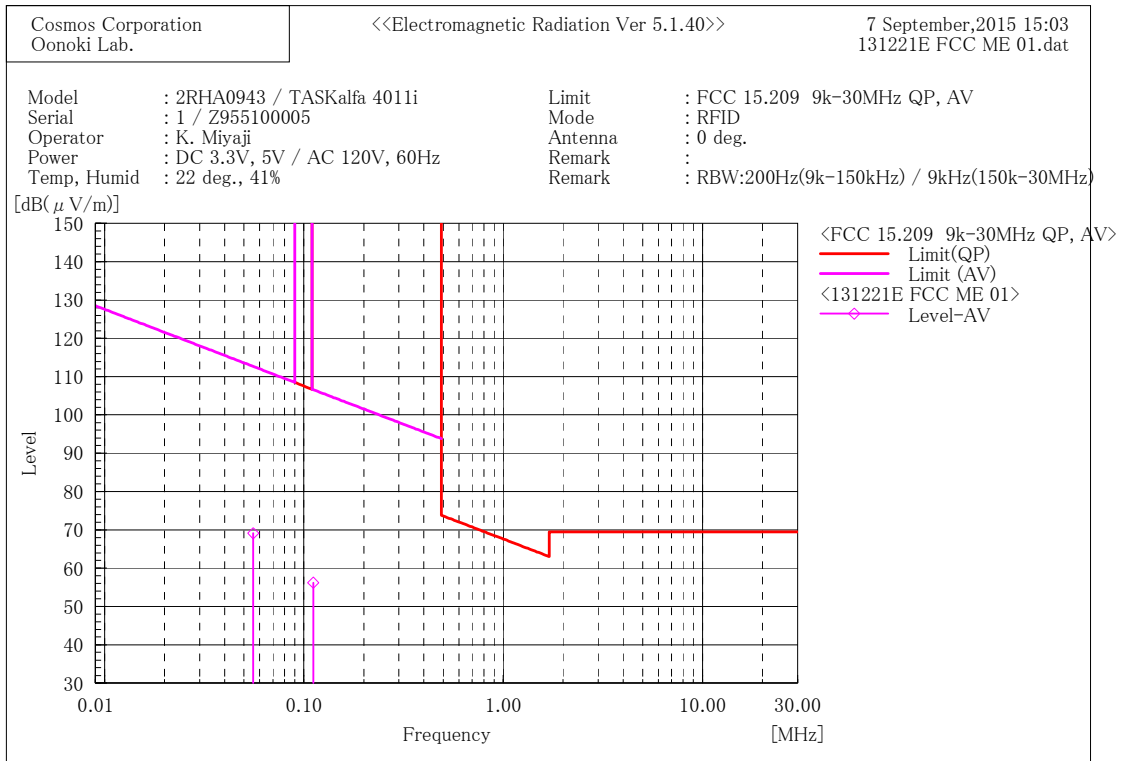

Final Result

No.	Frequency [MHz]	Reading AV [dB(μV)]	c. f [dB(1/m)]	Result AV [dB(μV/m)]	Limit AV [dB(μV/m)]	Margin AV [dB]	Angle [°]
1	0.0557	48.4	20.7	69.1	112.7	43.6	148.0
2	0.1114	35.6	20.6	56.2	106.6	50.4	149.0



### 5.2.3 Test Detail (Continued)

#### <Above 30 MHz> Test Data

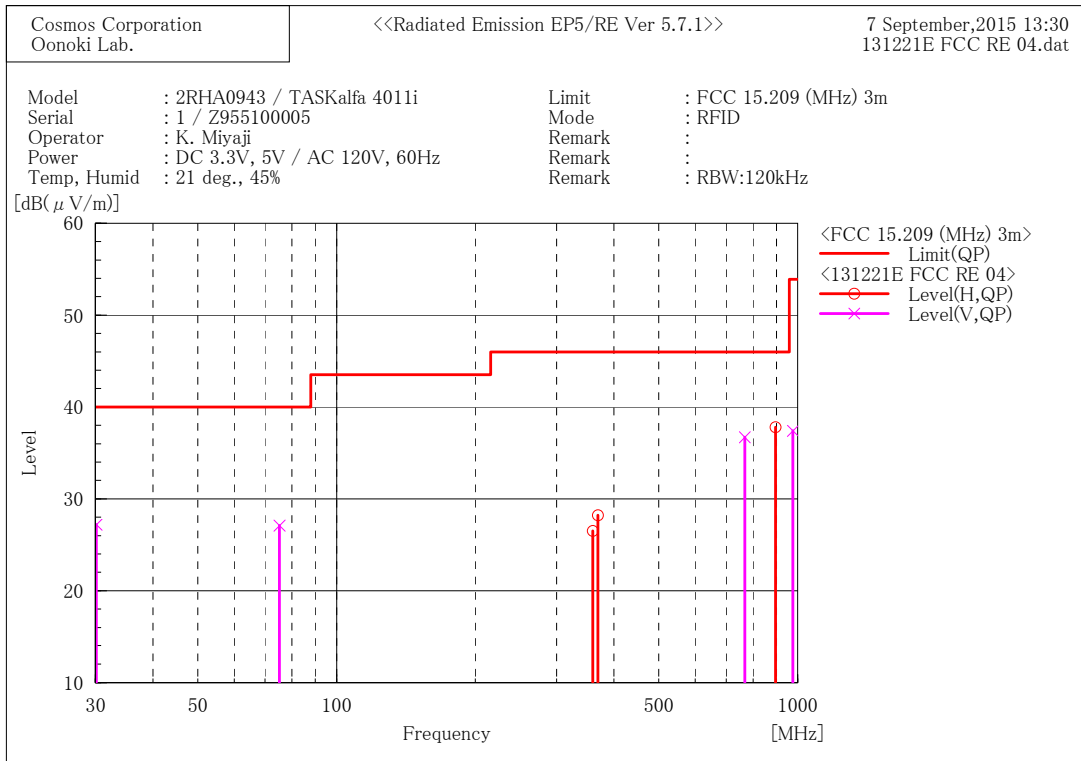

#### Final Result

##### --- Horizontal Polarization (QP)---

No.	Frequency [MHz]	Reading [dB(μV)]	c. f [dB(1/m)]	Result [dB(μV/m)]	Limit [dB(μV/m)]	Margin [dB]	Height [cm]	Angle [°]
1	359.542	31.9	-5.4	26.5	46.0	19.5	100.0	149.0
2	368.997	33.5	-5.3	28.2	46.0	17.8	100.0	163.0
3	894.972	33.5	4.3	37.8	46.0	8.2	143.0	328.0

##### --- Vertical Polarization (QP)---

No.	Frequency [MHz]	Reading [dB(μV)]	c. f [dB(1/m)]	Result [dB(μV/m)]	Limit [dB(μV/m)]	Margin [dB]	Height [cm]	Angle [°]
1	30.149	33.0	-5.8	27.2	40.0	12.8	100.0	194.0
2	75.186	44.0	-16.9	27.1	40.0	12.9	100.0	55.0
3	767.986	34.7	2.0	36.7	46.0	9.3	148.0	334.0
4	976.338	32.0	5.4	37.4	53.9	16.5	100.0	323.0



### 5.3 20 dB Bandwidth (15.215(c))

Result: PASS

#### 5.3.1 Setting Remarks

The both side of 20 dB down value from peak power were measured by using 20 dB bandwidth measurement function of the spectrum analyzer.

The spectrum analyzer is set as following:

- Resolution Bandwidth : 1% to 5% of the OBW (not less than 1 kHz)
- Video Bandwidth : greater than RBW
- Detector Mode : Peak
- Trace Mode : Max Hold

#### 5.3.2 Limit

Intentional radiators must be designed to ensure that the 20 dB bandwidth of the emission is contained within the frequency band designated in the rule section under which the equipment is operated.

#### 5.3.3 Test Detail

- Uncertainty of measurement result : ±0.011%
- Date of testing : November 24, 2015
- Room temperature : 22°C
- Relative humidity : 42%

<b>Measured Bandwidth [kHz]</b>
2.9

	<b>Edge of Bandwidth [MHz]</b>	<b>Limit [MHz]</b>	<b>Margin [kHz]</b>
Lower	13.5591	13.11	449
Higher	13.5620	14.01	448



### 5.3.3 Test Detail (Continued)

#### Test Data

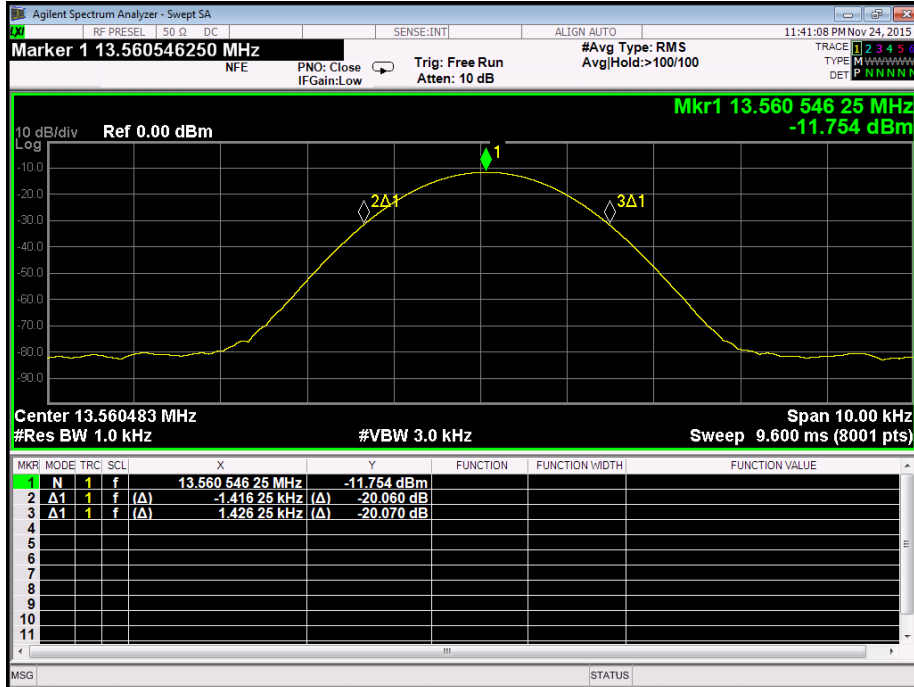



## 5.4 Field Strength of Fundamental Emission (15.225(a) (b) (c) (d), RSS-210 A2.6)

Result: PASS

### 5.4.1 Setting Remarks

The test setup was made in accordance with ANSI C63.10:2013 in a semi-anechoic chamber. The non-conductive board, 12 mm thick, was placed on the turntable, and the EUT was put on the non-conductive board. The turntable was fully rotated. The highest radiation from the equipment was recorded. The measurement was carried out with the measuring distance of 3 m. The test receiver with Quasi Peak detector is in accordance with CISPR 16-1-1. Then the limit of 30 m distance was converted to the limit of 3 m distance with the  $40\log(30\text{ m}/3\text{ m})$ .

### 5.4.2 Limit

Frequency range	Field Strength (Distance)	
	[ $\mu\text{V}/\text{m}$ ]	[dB $\mu\text{V}/\text{m}$ ]
13.553 MHz to 13.567 MHz	15848 (30 m)	123.9 (3 m)
13.410 MHz to 13.553 MHz and 13.567 MHz to 13.710 MHz	334 (30 m)	90.4 (3 m)
13.110 MHz to 13.410 MHz and 13.710 MHz to 14.010 MHz	106 (30 m)	80.5 (3 m)
Outside of 13.110 MHz to 14.010 MHz	30 (30 m)	69.5 (3 m)



### 5.4.3 Test Detail

Uncertainty of measurement result :  $\pm 4.64$  dB  
Date of testing : September 7, 2015      November 16, 2015  
Room temperature : 22°C      21°C  
Relative humidity : 41%      56%

#### Calculation

Result = Reading + c.f  
= 15.6 + 22.7  
= 38.3

Margin = Limit - Result  
= 69.5 - 38.3  
= 31.2

Result (3 m) = Reading + c.f  
= 40.9 + 22.2  
= 63.1

Result (30 m) = Result (3 m) - Conversion Factor  
= 63.1 - 40.0  
= 23.1

Margin = Limit - Result (30 m)  
= 83.9 - 23.1  
= 60.8

#### Note:

c.f (Correction Factor) = Cable Attenuation Factor + Antenna Factor



### 5.4.3 Test Detail (Continued)

[Test data of the module with the printer]  
**Worst Test Data (Antenna: 0°)**

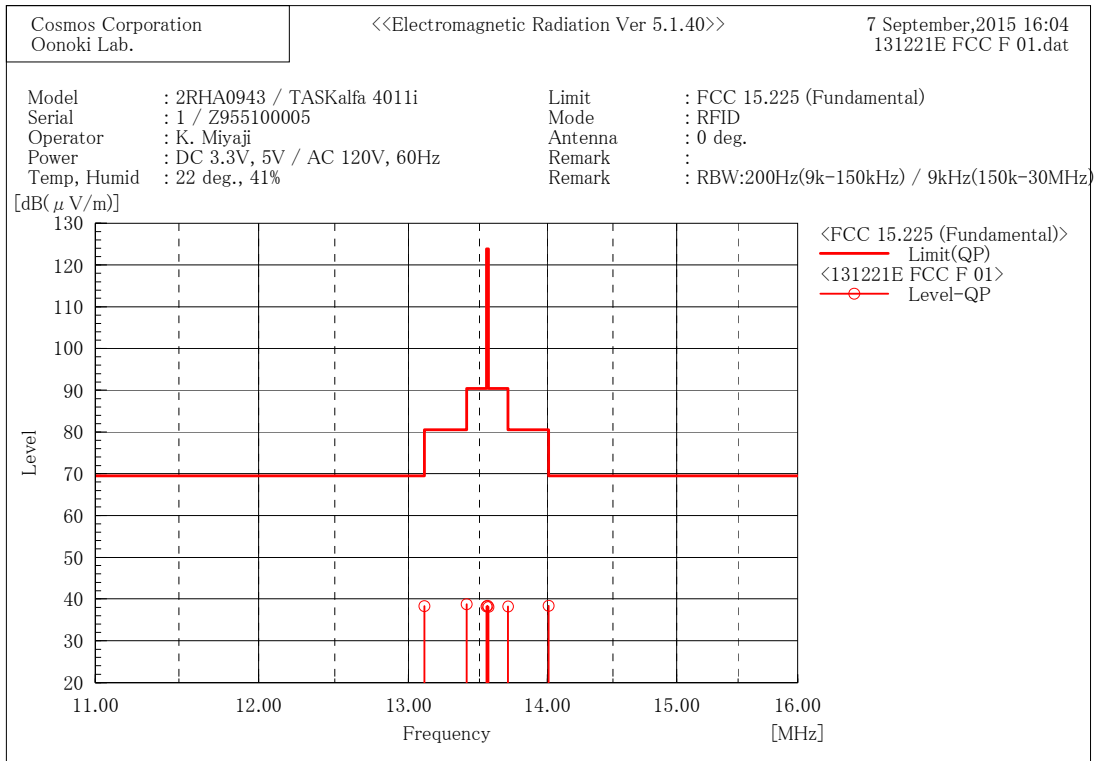

Final Result

No.	Frequency [MHz]	Reading [dB(μV)]	c. f [dB(1/m)]	Result [dB(μV/m)]	Limit [dB(μV/m)]	Margin [dB]	Angle [°]	Remark
1	13.110	15.6	22.7	38.3	69.5	31.2	37.0	
2	13.410	15.9	22.9	38.8	80.5	41.7	37.0	
3	13.553	15.2	23.0	38.2	90.4	52.2	37.0	
4	13.560	15.4	23.0	38.4	123.9	85.5	37.0	
5	13.567	15.1	23.0	38.1	90.4	52.3	37.0	
6	13.710	15.2	23.0	38.2	80.5	42.3	37.0	
7	14.010	15.2	23.2	38.4	69.5	31.1	37.0	



### 5.4.3 Test Detail (Continued)

[Test data of the module only]

**Test Data (Frequency Range: 13.553 MHz to 13.567 MHz)**

Frequency Range [MHz]	Measurement Frequency [MHz]	Power Supply Voltage [V]	Power Supply Voltage [V]	Antenna Polarization [deg.]	Reading [dBμV]	c.f. [dBBS/m]	Result [dBμV/m] (3m)	Conversion Factor [dB]	Result [dBμV/m] (30m)	Limit [dBμV/m]	Margin [dB]
13.553 - 13.567	13.560	2.805	4.25	90	40.9	22.2	63.1	40.0	23.1	83.9	60.8
	13.560		5.00	90	42.4	22.2	64.6	40.0	24.6	83.9	59.3
	13.560		5.75	90	43.7	22.2	65.9	40.0	25.9	83.9	58.0
	13.560	3.30	4.25	90	41.2	22.2	63.4	40.0	23.4	83.9	60.5
	13.560		5.00	90	42.2	22.2	64.4	40.0	24.4	83.9	59.5
	13.560		5.75	90	43.6	22.2	65.8	40.0	25.8	83.9	58.1
	13.560	3.795	4.25	90	41.5	22.2	63.7	40.0	23.7	83.9	60.2
	13.560		5.00	90	43.2	22.2	65.4	40.0	25.4	83.9	58.5
	13.560		5.75	90	44.5	22.2	66.7	40.0	26.7	83.9	57.2

**Test Data (Frequency Range: 13.410 MHz to 13.553 MHz)**

Frequency Range [MHz]	Measurement Frequency [MHz]	Power Supply Voltage [V]	Power Supply Voltage [V]	Antenna Polarization [deg.]	Reading [dBμV]	c.f. [dBBS/m]	Result [dBμV/m] (3m)	Conversion Factor [dB]	Result [dBμV/m] (30m)	Limit [dBμV/m]	Margin [dB]
13.41 - 13.553	13.553	2.805	4.25	90	26.8	22.2	49.0	40.0	9.0	50.4	41.4
	13.553		5.00	90	28.3	22.2	50.5	40.0	10.5	50.4	39.9
	13.553		5.75	90	29.5	22.2	51.7	40.0	11.7	50.4	38.7
	13.553	3.30	4.25	90	27.0	22.2	49.2	40.0	9.2	50.4	41.2
	13.553		5.00	90	27.9	22.2	50.1	40.0	10.1	50.4	40.3
	13.553		5.75	90	29.3	22.2	51.5	40.0	11.5	50.4	38.9
	13.553	3.795	4.25	90	27.3	22.2	49.5	40.0	9.5	50.4	40.9
	13.553		5.00	90	28.8	22.2	51.0	40.0	11.0	50.4	39.4
	13.553		5.75	90	30.1	22.2	52.3	40.0	12.3	50.4	38.1

**Test Data (Frequency Range: 13.567 MHz to 13.710 MHz)**

Frequency Range [MHz]	Measurement Frequency [MHz]	Power Supply Voltage [V]	Power Supply Voltage [V]	Antenna Polarization [deg.]	Reading [dBμV]	c.f. [dBBS/m]	Result [dBμV/m] (3m)	Conversion Factor [dB]	Result [dBμV/m] (30m)	Limit [dBμV/m]	Margin [dB]
13.567 - 13.71	13.567	2.805	4.25	90	29.3	22.2	51.5	40.0	11.5	50.4	38.9
	13.567		5.00	90	30.8	22.2	53.0	40.0	13.0	50.4	37.4
	13.567		5.75	90	32.0	22.2	54.2	40.0	14.2	50.4	36.2
	13.567	3.30	4.25	90	29.8	22.2	52.0	40.0	12.0	50.4	38.4
	13.567		5.00	90	30.8	22.2	53.0	40.0	13.0	50.4	37.4
	13.567		5.75	90	32.2	22.2	54.4	40.0	14.4	50.4	36.0
	13.567	3.795	4.25	90	30.2	22.2	52.4	40.0	12.4	50.4	38.0
	13.567		5.00	90	31.9	22.2	54.1	40.0	14.1	50.4	36.3
	13.567		5.75	90	33.2	22.2	55.4	40.0	15.4	50.4	35.0





5.4.3 Test Detail (Continued)

Test Data (Frequency Range: 13.110 MHz to 13.410 MHz)

Frequency Range [MHz]	Measurement Frequency [MHz]	Power Supply Voltage [V]	Power Supply Voltage [V]	Antenna Polarization [deg.]	Reading [dBμV]	c.f. [dBS/m]	Result [dBμV/m] (3m)	Conversion Factor [dB]	Result [dBμV/m] (30m)	Limit [dBμV/m]	Margin [dB]
13.11 - 13.41	13.41	2.805	4.25	90	4.8	22.2	27.0	40.0	-13.0	40.5	53.5
	13.41		5.00	90	4.8	22.2	27.0	40.0	-13.0	40.5	53.5
	13.41		5.75	90	4.8	22.2	27.0	40.0	-13.0	40.5	53.5
	13.41	3.30	4.25	90	4.8	22.2	27.0	40.0	-13.0	40.5	53.5
	13.41		5.00	90	4.8	22.2	27.0	40.0	-13.0	40.5	53.5
	13.41		5.75	90	4.8	22.2	27.0	40.0	-13.0	40.5	53.5
	13.41	3.795	4.25	90	4.8	22.2	27.0	40.0	-13.0	40.5	53.5
	13.41		5.00	90	4.8	22.2	27.0	40.0	-13.0	40.5	53.5
	13.41		5.75	90	4.8	22.2	27.0	40.0	-13.0	40.5	53.5

Test Data (Frequency Range: 13.710 MHz to 14.010 MHz)

Frequency Range [MHz]	Measurement Frequency [MHz]	Power Supply Voltage [V]	Power Supply Voltage [V]	Antenna Polarization [deg.]	Reading [dBμV]	c.f. [dBS/m]	Result [dBμV/m] (3m)	Conversion Factor [dB]	Result [dBμV/m] (30m)	Limit [dBμV/m]	Margin [dB]
13.71 - 14.01	13.71	2.805	4.25	90	4.8	22.3	27.1	40.0	-12.9	40.5	53.4
	13.71		5.00	90	4.8	22.3	27.1	40.0	-12.9	40.5	53.4
	13.71		5.75	90	4.8	22.3	27.1	40.0	-12.9	40.5	53.4
	13.71	3.30	4.25	90	4.8	22.3	27.1	40.0	-12.9	40.5	53.4
	13.71		5.00	90	4.8	22.3	27.1	40.0	-12.9	40.5	53.4
	13.71		5.75	90	4.8	22.3	27.1	40.0	-12.9	40.5	53.4
	13.71	3.795	4.25	90	4.8	22.3	27.1	40.0	-12.9	40.5	53.4
	13.71		5.00	90	4.8	22.3	27.1	40.0	-12.9	40.5	53.4
	13.71		5.75	90	4.8	22.3	27.1	40.0	-12.9	40.5	53.4

Test Data (Frequency Range: 12.660 MHz to 13.110 MHz)

Frequency Range [MHz]	Measurement Frequency [MHz]	Power Supply Voltage [V]	Power Supply Voltage [V]	Antenna Polarization [deg.]	Reading [dBμV]	c.f. [dBS/m]	Result [dBμV/m] (3m)	Conversion Factor [dB]	Result [dBμV/m] (30m)	Limit [dBμV/m]	Margin [dB]
12.66 - 13.11	13.11	2.805	4.25	90	4.8	22.2	27.0	40.0	-13.0	29.5	42.5
	13.11		5.00	90	4.8	22.2	27.0	40.0	-13.0	29.5	42.5
	13.11		5.75	90	4.8	22.2	27.0	40.0	-13.0	29.5	42.5
	13.11	3.30	4.25	90	4.8	22.2	27.0	40.0	-13.0	29.5	42.5
	13.11		5.00	90	4.8	22.2	27.0	40.0	-13.0	29.5	42.5
	13.11		5.75	90	4.8	22.2	27.0	40.0	-13.0	29.5	42.5
	13.11	3.795	4.25	90	4.8	22.2	27.0	40.0	-13.0	29.5	42.5
	13.11		5.00	90	4.8	22.2	27.0	40.0	-13.0	29.5	42.5
	13.11		5.75	90	4.8	22.2	27.0	40.0	-13.0	29.5	42.5

Test Data (Frequency Range: 14.010 MHz to 14.460 MHz)

Frequency Range [MHz]	Measurement Frequency [MHz]	Power Supply Voltage [V]	Power Supply Voltage [V]	Antenna Polarization [deg.]	Reading [dBμV]	c.f. [dBS/m]	Result [dBμV/m] (3m)	Conversion Factor [dB]	Result [dBμV/m] (30m)	Limit [dBμV/m]	Margin [dB]
14.01 - 14.46	14.01	2.805	4.25	90	4.8	22.3	27.1	40.0	-12.9	29.5	42.4
	14.01		5.00	90	4.8	22.3	27.1	40.0	-12.9	29.5	42.4
	14.01		5.75	90	4.8	22.3	27.1	40.0	-12.9	29.5	42.4
	14.01	3.30	4.25	90	4.8	22.3	27.1	40.0	-12.9	29.5	42.4
	14.01		5.00	90	4.8	22.3	27.1	40.0	-12.9	29.5	42.4
	14.01		5.75	90	4.8	22.3	27.1	40.0	-12.9	29.5	42.4
	14.01	3.795	4.25	90	4.8	22.3	27.1	40.0	-12.9	29.5	42.4
	14.01		5.00	90	4.8	22.3	27.1	40.0	-12.9	29.5	42.4
	14.01		5.75	90	4.8	22.3	27.1	40.0	-12.9	29.5	42.4



## 5.5 Frequency Stability (15.225(e), RSS-210 A2.6)

Result: PASS

### 5.5.1 Setting Remarks

The EUT was placed in an environmental test chamber, exposed in extreme temperatures until its temperature is stabilized. The measurement was carried out at every 10°C from -20°C to +50°C in the most common nominal supply voltage and the measurement was carried out at ±15% of rated voltage at 20°C.

### 5.5.2 Limit

The frequency stability of the carrier signal shall be maintained within ±0.01% of the operating frequency.

### 5.5.3 Test Detail

Uncertainty of measurement result : ±0.0021 Hz  
Date of testing : November 18 and 19, 2015  
Room temperature : Refer to Test Data

#### Calculation

Deviation [Hz] = Measured Frequency - Center Frequency  
= 13560430 - 13560000  
= 430

Deviation [ppm] = |Deviation [Hz]| ÷ Center Frequency × 1000000  
= |430| ÷ 13560000 × 1000000  
≐ 31.7

Margin = Limit - Deviation [ppm]  
= 100 - 31.7  
= 68.3



### 5.5.3 Test Detail (Continued)

Test Data

Temp [°C]	Operation Time	Measured Frequency [Hz]	Deviation [Hz]	Deviation [ppm]	Limit [ppm]	Margin [ppm]
50	Startup	13560430	430	31.7	100	68.3
	2 min	13560424	424	31.3	100	68.7
	5 min	13560422	422	31.1	100	68.9
	10 min	13560422	422	31.1	100	68.9
40	Startup	13560475	475	35.0	100	65.0
	2 min	13560468	468	34.5	100	65.5
	5 min	13560466	466	34.4	100	65.6
	10 min	13560465	465	34.3	100	65.7
30	Startup	13560518	518	38.2	100	61.8
	2 min	13560512	512	37.7	100	62.3
	5 min	13560509	509	37.6	100	62.4
	10 min	13560509	509	37.5	100	62.5
20	Startup	13560557	557	41.1	100	58.9
	2 min	13560557	557	41.1	100	58.9
	5 min	13560555	555	40.9	100	59.1
	10 min	13560554	554	40.9	100	59.1
10	Startup	13560593	593	43.7	100	56.3
	2 min	13560589	589	43.4	100	56.6
	5 min	13560588	588	43.3	100	56.7
	10 min	13560587	587	43.3	100	56.7
0	Startup	13560610	610	45.0	100	55.0
	2 min	13560609	609	44.9	100	55.1
	5 min	13560609	609	44.9	100	55.1
	10 min	13560608	608	44.9	100	55.1
-10	Startup	13560602	602	44.4	100	55.6
	2 min	13560605	605	44.6	100	55.4
	5 min	13560606	606	44.7	100	55.3
	10 min	13560606	606	44.7	100	55.3
-20	Startup	13560564	564	41.6	100	58.4
	2 min	13560571	571	42.1	100	57.9
	5 min	13560573	573	42.3	100	57.7
	10 min	13560573	573	42.3	100	57.7



**5.5.3 Test Detail (Continued)**

**Test Data**

Supply Voltage [V]	Supply Voltage [V]	Measured Frequency [Hz]	Deviation [Hz]	Deviation [ppm]	Limit [ppm]	Margin [ppm]
2.805	4.25	13560582	582	42.9	100	57.1
	5.00	13560585	585	43.2	100	56.8
	5.75	13560586	586	43.2	100	56.8
3.300	4.25	13560547	547	40.3	100	59.7
	5.00	13560554	554	40.9	100	59.1
	5.75	13560551	551	40.6	100	59.4
3.795	4.25	13560486	486	35.8	100	64.2
	5.00	13560488	488	36.0	100	64.0
	5.75	13560490	490	36.1	100	63.9

**Test Data**

Temp [°C]	Supply Voltage [V]	Supply Voltage [V]	Measured Frequency [Hz]	Deviation [Hz]	Deviation [ppm]	Limit [ppm]	Margin [ppm]
50	3.3	5	13560422	-133	9.8	100	90.2
20			13560554	reference value			
-20			13560573	19	1.4	100	98.6
20	2.805	4.25	13560582	27	2.0	100	98.0
		5.00	13560585	31	2.3	100	97.7
		5.75	13560586	32	2.4	100	97.6
	3.300	4.25	13560547	-8	0.6	100	99.4
		5.75	13560551	-3	0.2	100	99.8
	3.795	4.25	13560486	-69	5.1	100	94.9
		5.00	13560488	-67	4.9	100	95.1
		5.75	13560490	-65	4.8	100	95.2



## 5.6 Occupied Bandwidth (RSS-Gen Annex A)

Result: PASS

### 5.6.1 Setting Remarks

EUT directly connects to the spectrum analyzer via calibrated coaxial cable and 10 dB attenuator.  
The spectrum analyzer is set-up as following;

· Resolution Bandwidth	: Approx. 1% of the span
· Video Bandwidth	: $3 \times \text{RBW}$
· Sweep	: Auto
· Detector Mode	: RMS
· Trace Mode	: Max Hold

### 5.6.2 Test Detail

Uncertainty of measurement result	: $\pm 0.011\%$
Date of testing	: November 24, 2015
Room temperature	: $22^{\circ}\text{C}$
Relative humidity	: 42%



### 5.6.2 Test Detail (Continued)

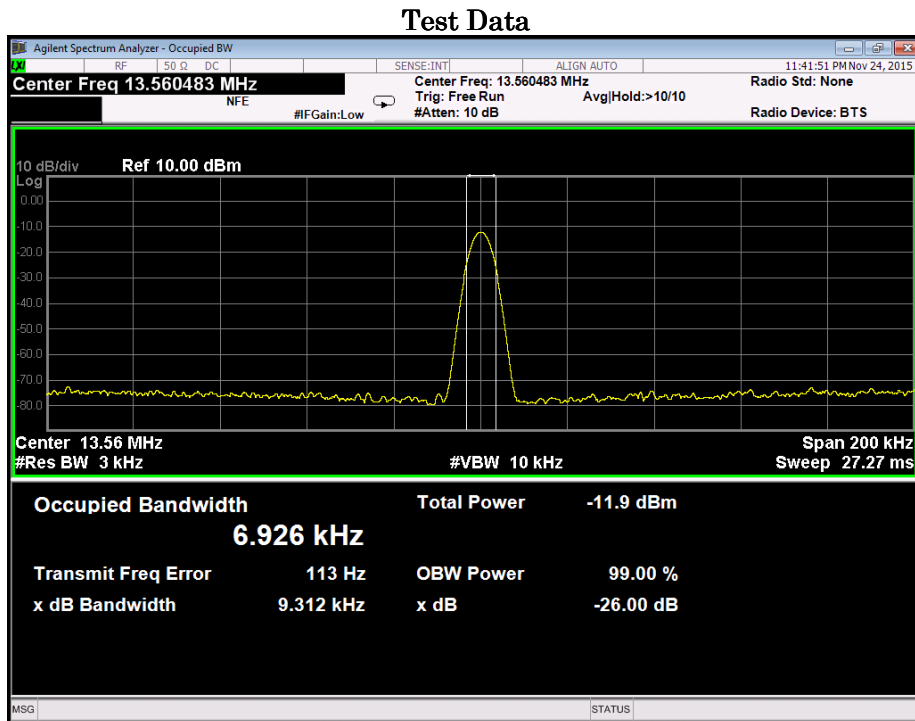



## 6. List of Test and Measurement Instruments

### AC Power Line Conducted Emission

Instruments	Manufacturer	Model	Serial No.	Calibrated Date/Until
EMI Test Receiver	Agilent Technologies	N9038A	MY54130015	2015/06/29 2016/06/28
Artificial-Mains Network /Highpass Filter /Attenuator 10 dB	Kyoritsu /Kyoritsu /TAMAGAWA	KNW-341C (F) /KFL-007 /CFA-03	8-1659-1 /8-1708-10 /---	2015/06/18 2016/06/17
Artificial-Mains Network /Highpass Filter /Attenuator 10 dB	Kyoritsu /Kyoritsu /JFW	KNW-341 F /KFL-007 / 50FP-010-H2	8S-2996-1 /8-1741-2 /---	2015/06/25 2016/06/24
RF Cable RF Selector (9 kHz to 30 MHz)	Fujikura	5D-2W	OC09	2015/05/11 2016/05/10
	SUHNER	RG223/U	OC10 OC11 OC12	
	TSJ	RFM-E121	03149	
50 Ω Terminator	RES-NET MICROWAVE	RCX6BM	---	2015/05/28 2016/05/27
Software	TOYO	EP5/CE (ver 5.4.40)	---	---

### Transmitter Spurious Emission (Radiated) (Below 30 MHz) Field Strength of Fundamental Emission

Instruments	Manufacturer	Model	Serial No.	Calibrated Date/Until
EMI Test Receiver	Agilent Technologies	N9038A	MY54130015	2015/06/29 2016/06/28
				2015/10/14 2016/10/13
Loop Antenna (9 kHz to 30 MHz)	SCHAFFNER	HLA6120	1137	2014/10/05 2015/10/04
				2015/11/06 2016/11/05
Anechoic Chamber 3 m	JSE	COAC3M-01	---	2015/05/07 2016/05/06
RF Cable RF Selector (9 kHz to 30 MHz)	Fujikura	5D-2W	OC09	2015/05/11 2016/05/10
	SUHNER	RG223/U	OC10 OC11 OC12	
	TSJ	RFM-E121	03149	
Software	TOYO	EP5/ME (ver 5.1.40)	---	---



## 6. List of Test and Measurement Instruments (Continued)

### Transmitter Spurious Emission (Radiated) (Above 30 MHz)

Instruments	Manufacturer	Model	Serial No.	Calibrated Date/Until
EMI Test Receiver	Agilent Technologies	N9038A	MY54130015	2015/06/29 2016/06/28
Pre-Amplifier (30 MHz to 1 GHz)	HEWLETT PACKARD	8447D OPT 010	2944A 07891	2015/03/13 2016/03/12
Biconical Antenna (30 MHz to 300 MHz)	SCHWARZBECK	VHBB9124 / BBA9106	9124-311	2015/08/31 2016/08/30
Log-Periodic Antenna (300 MHz to 1 GHz)	SCHWARZBECK	UHALP9108-A	0645	2015/08/31 2016/08/30
Anechoic Chamber 3 m	JSE	COAC3M-01	---	2015/05/07 2016/05/06
Attenuator 3 dB	JFW	50FP-003-H2	---	2015/03/13 2016/03/12
RF Cable RF Selector (30 MHz to 1 GHz)	Fujikura	8D-2W	OC14	2015/05/11 2016/05/10
	SUHNER	RG223/U	OC11	
		RG214/U	OC15 OC16	
		RG400/U	OC17	
	TSJ	RFM-E121	03149	
Software	TOYO	EP5/RE (ver 5.7.1)	---	---

### 20 dB Bandwidth / Frequency Stability / Occupied Bandwidth

Instruments	Manufacturer	Model	Serial No.	Calibrated Date/Until
EMI Test Receiver	Agilent Technologies	N9038A	MY54130015	2015/10/14 2016/10/13
Thermostatic Chamber	ESPEC	PU-2KP	14010409	2015/08/07 2016/08/06





## 7. Appendix

Refer to separated files for the following appendixes.

Appendix 1: Angle of EUT

Appendix 2: Photographs of EUT (RFID Module)

Appendix 3: Photographs of the Test Setup