

OMRON

Model **V640-HAM11-V4**
 Model **V640-HAM11-L-V2**
Amplifier Unit

INSTRUCTION SHEET

Thank you for selecting OMRON product. This sheet primarily describes precautions required in installing and operating the product.
 Before operating the product, read the sheet thoroughly to acquire sufficient knowledge of the product. For your convenience, keep the sheet at your disposal.

TRACEABILITY INFORMATION:
 Representative in EU: Omron Europe B.V., Wegalaan 67-69, 2132 JD Hoofddorp, The Netherlands
 Manufacturer: Omron Corporation, Shiokoji Horikawa, Shimogyo-ku, Kyoto 600-8530 JAPAN
 Ayabe Factory 3-2 Narutani, Nakayama-cho, Ayabe-shi, Kyoto 623-0105 JAPAN



© OMRON Corporation 2015 All Rights Reserved.

PRECAUTION FOR SAFE USE

- Ensure safety, be absolutely sure to follow the instructions below:
 - Never use the product in an environment where combustible or explosive gas is present.
 - Please separate from a high-pressure equipment and the power equipment to secure the safety of the operation and maintenance.
 - In the installation, please tighten the screw surely. (Recommended 1.2N·m)
 - Please do not insert foreign bodies such as water and the wires from the space of the case.
 - Please do not dismantle, repair or modify this product.
 - Please process as industrial waste when you abandon this product.
 - When you work on wiring and put on and take off cables, CIDRW head, please perform it after switching off this product.
 - Provide enough space around this product for ventilation.
 - Please avoid installing this product near the machinery (a heater, a transformer, large-capacity resistance) that has high the calorific value.
 - Please talk to our office by any chance after you cancel use immediately when you felt abnormality to this product, and having switched it off.

PRECAUTION FOR CORRECT USE

- About installation site

Do not install this product in the locations subject to the following conditions.

 - Place where direct sunshine strikes
 - Place with corroded gas, dust, metallic powder, and salinity
 - Place with condensation due to rapid temperature fluctuations.
 - Place with condensation due to high humidity.
 - Place where vibration and impact more than being provided by specification are transmitted directly to main body.
 - Place with spray of water, oil, and chemical medicine.
 - The working temperature is within the range stipulated in the specifications.
- About depository site
 - Please follow the save ambient temperature / humidity, and keep this product.
- About wiring
 - Use the power supply voltage specified in this document.
 - Ensure correct polarity when connecting to the +/- power supply terminals.
 - Do not run high-voltage lines and power lines though the same conduit.
 - To avoid static-induced failure, wear a wrist band or equivalent means to release a static charge before touching a terminal or a signal line within a connector.
 - When you put on and take off a CIDRW head, please do not add excessive power to a connector.
 - Please connect the correct CIDRW head to the amplifier unit.

- About cleaning
 - Use alcohol to clean this product.
 - NEVER use an organic solvent such as thinner, benzene, acetone or kerosene, as it will attack resin components or case coating.
- Power and Graound Cables
 - Use an appropriate ground. An insufficient ground can affect this product operation or result in damage to this product.
- About the communication range and time
 - Do the communication test with Transponder in the installation environment because the metal, noise and ambient temperature around CIDRW head damage to the communication range and time.
 - Install CIDRW head and ID tag in the appropriate distance because the communication range can change by the difference of ID tag specifications.
- About mounting
 - This product communicates with ID Tags using the 134 kHz frequency band. Some transceivers, motors, monitoring equipment, and power supplies (power supply ICs) generate electrical waves (noise) that interfere with communications with ID Tags. If you are using the product in the vicinity of any of these devices, check the effect on communications in advance.
 - In order to minimize the effects of noise, ground nearby metal bodies with a grounding resistance not exceeding 100 ohms.
 - When multiple CIDRW Heads are mounted next to each other, communications performance could be impaired by mutual interference. Read and follow the information in this manual on mutual interference when installing multiple heads.
 - When mounting CIDRW Heads, tighten the screws tightly. (Recommended 0.6N·m)

- Screw Locking Adhesive
 - Screw locking adhesive (screw lock) may cause deterioration and cracking of resin parts; do not use it for screws in resin parts or anywhere where resin washers are used.
- Communications with the Host Device
 - Communicate with the host device only after confirming that the CIDRW Controller has started. Also, unstable signals may occur at the host interface when the CIDRW Controller is started. When initializing operation, clear the reception buffer at the host device or take other suitable methods to clear unwanted signals.
- Startup precaution
 - Never turn OFF the power supply while the CIDRW Controller is starting, including when power is turned ON, when the mode is changed, or when the CIDRW Controller is being reset. Doing so may damage the CISRW Controller.
- About Transponder and RF module made by Texas Instruments Co.
 - We can't warrant the specifications of the communication with Transponder and RF module.
 - When the RF module is at fault, we can't analyze the RF module.
- The characteristics of the V640-HAM11-V3 / V640-HAM11-V4
 - It is a circuit, designed to communicate characteristics match, but because it is intended to carry out the communication with RF module and the transponder, can not be guaranteed.

General specifications

Characteristic	Specification	
	V640-HAM11-V4	V640-HAM11-L-V2
Supply voltage	24 VDC, +10%, -15%	
Current consumption	150 mA max	400 mA max
Protection rating	IP20 (IEC 60529)	
Ambient temperature	Operating: 0°C to +40°C Storage: -15°C to +65°C (No freezing, No dew condensation)	
Ambient humidity	Operating/Storage: 35% to 85% (No freezing, No dew condensation)	
Insulation resistance	20M Ω min. (100V DC for appliance) (between power supply terminal and frame grounding terminal)	
Dielectric	1000V AC (50/60Hz, for 1 min.) leak current consumption 5mA max. (between power supply terminal and frame grounding terminal)	
Vibration resistance	10 to 150Hz, 0.20mm double amplitude, acceleration 15m/s ² , with 10 sweeps of 8min each in 3 directions	
Shock resistance	150m/s ² , 3 times each in 6 directions	
Environmental pollution degree	Degree 2	
Over voltage category	Category I	
Mounting system	Secured with four M4 screws. (tightening torque: 1.2 N·m)	
CIDRW head	V640-HS61	V640-HS62
Applied standards	USA / Europe / Japan / Canada	

Names and functions

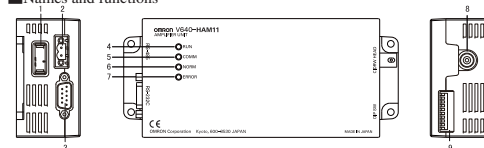

- RS-232C port (3)
This port is for connection to the host or the CIDRW controller: V700-L22 according to RS-232C interface standard.
- RS-485 port (2)
If two or more Amplifier units are connected to one RS-232C port of a host or a CIDRW controller: model V700-L22, this RS-485 port is connected to a RS-485 port on another amplifier unit. An RS-485 port (if any) on the host can be connected to this port. However the RS-232C port and the RS-485 port are unable to be used at the same time.
- CIDRW head connection port (8)
A port dedicated to connection of a CIDRW head.
- Status indicators (4-7)
Four indicator lamps (RUN, COMM, NORM, ERROR) indicate the current operating status of the amplifier unit.
- Setup DIP-SW (9)
This switch array allows the operator to assign ID No. to amplifier unit and define various operating conditions. DIP-SW settings: factory-setting is all OFF

No.	Description	Meaning (Content within a box represents factory-setting)
1	Node No.1	01~31 No. 1 is LSB, and No. 5 is MSB.
2	Node No.2	When all switches are ON, this amplifier unit selects 1:1 protocol.
3	Node No.3	
4	Node No.4	
5	Node No.5	
6	Baud rate setting 1	38400 / 19200 / 9600 / 4800bps
7	Baud rate setting 2	[ON,ON] / [ON,OFF] / [OFF,OFF] / [OFF,ON] : [No7, No6]
8	Reserved	Please turn off this SW.
9	Test mode	[OFF] / [ON]
10	RS-485 terminator	[OFF] / [ON]

- Set the RS-485 terminator setting to ON for the amplifier units on both ends of multidrop, and to OFF for other units. If only one amplifier unit is operated, set the terminator setting to ON.
- 24VDC power terminals (1)
Recommended cable : AWG20 - 24
Recommended connector : Model 1-178288-3 (Tyco Electronics Co.)
Recommended compression ring : Model 175217-3 (Tyco Electronics Co.)
(These connector and compression ring are supplied with model V640-A90.)
Recommended 24 V power supply : Model 58VS-01524(OMRON)

- Use the product below as a crimping tool for crimping the compression ring. Model 919601-1 (Tyco Electronics Co.)
- Cables for RS-485 port
Recommended cable : Model MVS 2CX0.55Q (Tachii Densen Co.)
Recommended compression ring : Molde A10.5-8WH (Phoenix Contact Co.)
- *The following product is recommended as a compression ring for connecting two cables to one terminal. Model AI-TWIN2 -0.5-8WH (Phoenix Contact Co.)
- *Use the product below as a crimping tool for crimping the compression ring. Model CRIMPFOX UD6 (Phoenix Contact Co.)

How to connect cables

- Fit a compression ring to the stripped section of each cable.
- Next, being sure of the connector orientation, insert each cable into a corresponding hole on the connector.
- Securely fasten each cable using the cable locking screw on the connector.
- An ordinary screwdriver whose shank is tapered at the tip does not go all the way into the hole. Use a miniature flat-blade screwdriver with a straight shank. Tighten the cable locking screws at an appropriated tightening torque (approx. 0.3 N·m).

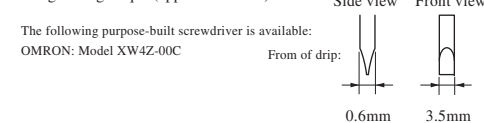

The following purpose-built screwdriver is available:
 OMRON: Model XW44Z-00C

- Connect the connector to the amplifier unit together with the cables. Match the orientation of amplifier unit side connector with that of cable side connector, insert the cable side connector all the way, and then tighten the connector lock screws.
- When removing the connector, fully loosen the two lock screws and draw out it straight by holding the protrusions on connector. If the connector does not easily come loose, draw it out while holding down the link unit proper.

Dimensions

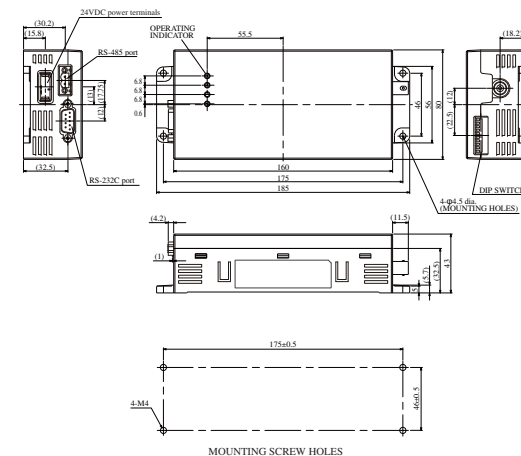

material PC+ABS (Unit: mm)

* Be sure to limit the tightening torque for the M4 screws as 1.2 N·m.

Suitability for Use

Omron Companies shall not be responsible for conformity with any standards, codes or regulations which apply to the combination of the Product in the Buyer's application or use of the Product. At Buyer's request, Omron will provide applicable third party certification documents identifying ratings and limitations of use which apply to the Product. This information by itself is not sufficient for a complete determination of the suitability of the Product in combination with the end product, machine, system, or other application or use. Buyer shall be solely responsible for determining appropriateness of the particular Product with respect to Buyer's application, product or system. Buyer shall take application responsibility in all cases.

NEVER USE THE PRODUCT FOR AN APPLICATION INVOLVING SERIOUS RISK TO LIFE OR PROPERTY WITHOUT ENSURING THAT THE SYSTEM AS A WHOLE HAS BEEN DESIGNED TO ADDRESS THE RISKS, AND THAT THE OMRON PRODUCT(S) IS PROPERLY RATED AND INSTALLED FOR THE INTENDED USE WITHIN THE OVERALL EQUIPMENT OR SYSTEM.
 See also Product catalog for Warranty and Limitation of Liability.

OMRON Corporation Industrial Automation Company
 Tokyo, JAPAN Contact: www.ia.omron.com

- Regional Headquarters
 - OMRON EUROPE B.V.
Sensor Business Unit
Carl-Benz-Str. 4, D-71154 Nufringen, Germany
Tel: (49) 7032-811-0/Fax: (49) 7032-811-199
 - OMRON ELECTRONICS LLC
2895 Greenspoint Parkway, Suite 200
Hoffman Estates, IL 60169 U.S.A.
Tel: (1) 847-843-7900/Fax: (1) 847-843-7787
 - OMRON ASIA PACIFIC PTE. LTD.
No. 438A Alexandra Road # 05-05/08 (Lobby 2),
Alexandra Technopark,
Singapore 119967
Tel: (65) 6855-3011/Fax: (65) 6835-2711
 - OMRON (CHINA) CO., LTD.
Room 2211, Bank of China Tower,
200 Yin Cheng Zhong Road,
FuDong New Area, Shanghai, 200120, China
Tel: (86) 21-5037-2222/Fax: (86) 21-5037-2200

Oct, 2014

法規と規格/Regulations and Standards

以下の海外法規、規格に対応しています。

The Products conform to the following regulations and standards.

1. 米国/The United States

FCC ID	アンテナユニット/Amplifier Unit	CIDRWヘッド/CIDRW Head
E4EV640HAM11V2	V640-HAM11-V4 V640-HAM11-ETN-V2	V640-HS61
E4EV640HAM11LV2	V640-HAM11-L-V2 V640-HAM11-L-ETN-V2	V640-HS62

FCC NOTICE

This device complies with part 15 of the FCC Rules. Operation is subject to the following two conditions:

- (1) This device may not cause harmful interference.
- (2) This device must accept any interference received, including interference that may cause undesired operation.

FCC WARNING

Changes or modifications not expressly approved by the party responsible for compliance could void the user's authority to operate the equipment. Do not remove the ferrite core (TDK Type ZCAT2035-0930A:V640-HS62) installed on the cables to suppress RF interference.

FCC Part15 subpart B

NOTICE

This equipment has been tested and found to comply with limits for a Class A digital device, pursuant to part15 of the FCC Rules. These limits are designed to provide reasonable protection against harmful interference when the equipment is operated in a commercial environment.

This equipment generates, uses and can radiate radio frequency energy and, if not installed and used in accordance with the instructions, may cause harmful interference to radio communications. Operation of this equipment in a residential area is likely to cause harmful interference in which case the user will be required to correct the interference at his own expense.

CAUTION

This device must be professionally installed.

2. カナダ Canada

IC ID	アンテナユニット/Amplifier Unit	CIDRWヘッド/CIDRW Head
850J-V640HAM11V2	V640-HAM11-V4 V640-HAM11-ETN-V2	V640-HS61
850J-V640HAM11L2	V640-HAM11-L-V2 V640-HAM11-L-ETN-V2	V640-HS62

This device complies with Industry Canada's licence-exempt RSSs.

Operation is subject to the following two conditions:

- (1) This device may not cause interference, and
- (2) This device must accept any interference, including interference that may cause undesired operation of the device.

Le présent appareil est conforme aux CNR d'Industrie Canada applicables aux appareils radio exempts de licence.

L'exploitation est autorisée aux deux conditions suivantes :

- (1) l'appareil ne doit pas produire de brouillage, et
- (2) l'utilisateur de l'appareil doit accepter tout brouillage radioélectrique subi, même si le brouillage est susceptible d'en compromettre le fonctionnement.

CAN ICES-3(A) / NMB-3(A)

WARNING

Changes or modifications not expressly approved by the party responsible for compliance for could void the user's authority to operate the equipment. Do not remove the ferrite core (TDK Type ZCAT2035-0930A:V640-HS62) installed on the cables to suppress RF interference.

Les changements ou modifications non expressément approuvés par la partie responsable de la conformité pourraient annuler l'autorité de l'utilisateur à utiliser l'équipement.

Ne pas retirer le noyau de ferrite (TDK type ZCAT2035-0930A: V640-HS62) installé sur les câbles pour supprimer les interférences RF.

CAUTION:

This device must be professionally installed.

Cet appareil doit être installé par un professionnel.