

RFID System

V680 Series

User's Manual

Amplifier and Antennas

V680-HA63A

V680-HS52

V680-HS63

ID Tags

V680-D1KP52MT

V680-D1KP66T

V680-D1KP66MT

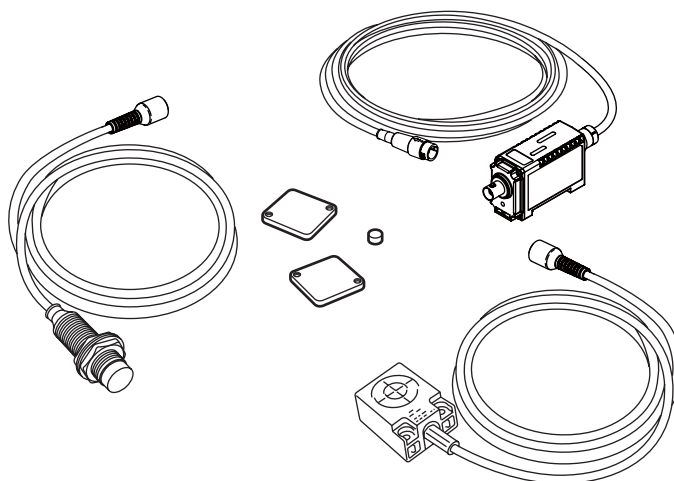

Introduction

Thank you for purchasing a V680-series RFID System. This manual describes the functions, performance, and application methods needed for optimum use of the V680-series RFID System.

Please observe the following items when using the RFID System.

- Allow the RFID System to be installed and operated only by qualified specialist with a sufficient knowledge of electrical systems.
- Read and understand this manual before attempting to use the RFID System and use the RFID System correctly.
- Keep this manual in a safe and accessible location so that it is available for reference when required.

| | | |
|--------------|-----------------------------------|--------------|
| Introduction | READ AND UNDERSTAND THIS DOCUMENT | Introduction |
| Section 1 | Product Overview | Section 1 |
| Section 2 | Specifications and Performance | Section 2 |
| Section 3 | Communications Specifications | Section 3 |
| Section 4 | Installation | Section 4 |
| Section 5 | Chemical Resistance | Section 5 |

RFID System

| | |
|---------------|-----------|
| V680-HA63A | Amplifier |
| V680-HS52 | Antenna |
| V680-HS63 | Antenna |
| V680-D1KP52MT | ID Tag |
| V680-D1KP66T | ID Tag |
| V680-D1KP66MT | ID Tag |

User's Manual

READ AND UNDERSTAND THIS DOCUMENT

Please read and understand this document before using the products. Please consult your OMRON representative if you have any questions or comments.

WARRANTY

OMRON's exclusive warranty is that the products are free from defects in materials and workmanship for a period of one year (or other period if specified) from date of sale by OMRON.

OMRON MAKES NO WARRANTY OR REPRESENTATION, EXPRESS OR IMPLIED, REGARDING NON-INFRINGEMENT, MERCHANTABILITY, OR FITNESS FOR PARTICULAR PURPOSE OF THE PRODUCTS. ANY BUYER OR USER ACKNOWLEDGES THAT THE BUYER OR USER ALONE HAS DETERMINED THAT THE PRODUCTS WILL SUITABLY MEET THE REQUIREMENTS OF THEIR INTENDED USE. OMRON DISCLAIMS ALL OTHER WARRANTIES, EXPRESS OR IMPLIED.

LIMITATIONS OF LIABILITY

OMRON SHALL NOT BE RESPONSIBLE FOR SPECIAL, INDIRECT, OR CONSEQUENTIAL DAMAGES, LOSS OF PROFITS OR COMMERCIAL LOSS IN ANY WAY CONNECTED WITH THE PRODUCTS, WHETHER SUCH CLAIM IS BASED ON CONTRACT, WARRANTY, NEGLIGENCE, OR STRICT LIABILITY.

In no event shall responsibility of OMRON for any act exceed the individual price of the product on which liability is asserted.

IN NO EVENT SHALL OMRON BE RESPONSIBLE FOR WARRANTY, REPAIR, OR OTHER CLAIMS REGARDING THE PRODUCTS UNLESS OMRON'S ANALYSIS CONFIRMS THAT THE PRODUCTS WERE PROPERLY HANDLED, STORED, INSTALLED, AND MAINTAINED AND NOT SUBJECT TO CONTAMINATION, ABUSE, MISUSE, OR INAPPROPRIATE MODIFICATION OR REPAIR.

SUITABILITY FOR USE

THE PRODUCTS CONTAINED IN THIS DOCUMENT ARE NOT SAFETY RATED. THEY ARE NOT DESIGNED OR RATED FOR ENSURING SAFETY OF PERSONS, AND SHOULD NOT BE RELIED UPON AS A SAFETY COMPONENT OR PROTECTIVE DEVICE FOR SUCH PURPOSES. Please refer to separate catalogs for OMRON's safety rated products.

OMRON shall not be responsible for conformity with any standards, codes, or regulations that apply to the combination of products in the customer's application or use of the product.

At the customer's request, OMRON will provide applicable third party certification documents identifying ratings and limitations of use that apply to the products. This information by itself is not sufficient for a complete determination of the suitability of the products in combination with the end product, machine, system, or other application or use.

The following are some examples of applications for which particular attention must be given. This is not intended to be an exhaustive list of all possible uses of the products, nor is it intended to imply that the uses listed may be suitable for the products:

- Outdoor use, uses involving potential chemical contamination or electrical interference, or conditions or uses not described in this document.
- Nuclear energy control systems, combustion systems, railroad systems, aviation systems, medical equipment, amusement machines, vehicles, safety equipment, and installations subject to separate industry or government regulations.
- Systems, machines, and equipment that could present a risk to life or property.

Please know and observe all prohibitions of use applicable to the products.

NEVER USE THE PRODUCTS FOR AN APPLICATION INVOLVING SERIOUS RISK TO LIFE OR PROPERTY WITHOUT ENSURING THAT THE SYSTEM AS A WHOLE HAS BEEN DESIGNED TO ADDRESS THE RISKS, AND THAT THE OMRON PRODUCT IS PROPERLY RATED AND INSTALLED FOR THE INTENDED USE WITHIN THE OVERALL EQUIPMENT OR SYSTEM.

PERFORMANCE DATA

Performance data given in this document is provided as a guide for the user in determining suitability and does not constitute a warranty. It may represent the result of OMRON's test conditions, and the users must correlate it to actual application requirements. Actual performance is subject to the OMRON Warranty and Limitations of Liability.

CHANGE IN SPECIFICATIONS

Product specifications and accessories may be changed at any time based on improvements and other reasons.

It is our practice to change model numbers when published ratings or features are changed, or when significant construction changes are made. However, some specifications of the product may be changed without any notice. When in doubt, special model numbers may be assigned to fix or establish key specifications for your application on your request. Please consult with your OMRON representative at any time to confirm actual specifications of purchased products.

DIMENSIONS AND WEIGHTS

Dimensions and weights are nominal and are not to be used for manufacturing purposes, even when tolerances are shown.

ERRORS AND OMISSIONS

The information in this document has been carefully checked and is believed to be accurate; however, no responsibility is assumed for clerical, typographical, or proofreading errors, or omissions.

PROGRAMMABLE PRODUCTS

OMRON shall not be responsible for the user's programming of a programmable product, or any consequence thereof.

COPYRIGHT AND COPY PERMISSION

This document shall not be copied for sales or promotions without permission. This document is protected by copyright and is intended solely for use in conjunction with the product. Please notify us before copying or reproducing this document in any manner, for any other purpose. If copying or transmitting this document to another, please copy or transmit it in its entirety.

Safety Precautions

Alert Symbols for Safe Use

The following symbols are used in this manual to indicate precautions that must be observed to ensure safe use of the V680-HS63, V680-HS52, and V680-HA63A. The precautions provided here contain important safety information. Be sure to observe these precautions.

The following signal words are used in this manual.



Indicates a potentially hazardous situation which, if not avoided, will result in minor or moderate injury, or may result in serious injury or death. Additionally, there may be significant property damage.

Meanings of Alert Symbols



Indicates general prohibitions for which there is no specific symbol.

Warning



These Products are not designed to be used either directly or indirectly in applications that detect human presence for the purpose of maintaining safety. Do not use these Products as a sensing means for protecting human lives.

Regulations and Standards

The V680-HS63, V680-HS52, and V680-HA63A conform to the following overseas regulations and standards.

1. FCC Rules (Federal Communications Commission)
This product complies with Part 15 Subpart C of the FCC Rules.
FCC ID: E4E6CYSIDV6800406

FCC NOTICE

This device complies with part 15 of the FCC Rules. Operation is subject to the following two conditions:

- (1) This device may not cause harmful interference.
- (2) This device must accept any interference received, including interference that may cause undesired operation.

FCC WARNING

Changes or modifications not expressly approved by the party responsible for compliance could void the user's authority to operate the equipment.

Do not remove the ferrite core (TDK Type ZCAT1730-0730A) installed on the cables to suppress RF interference.

2. EC Declaration of Conformity

Hereby, OMRON Corporation declares that this RFID System, Antenna V680-HS52, V680-HS63, and Amplifier V680-HA63A. Amplifier and Antenna are in compliance with essential requirements and other relevant provisions of Directive 1995/5/EC, and satisfy tests for the appropriate requirements of the following relevant standards.

Radio: EN 300 330-2V1.1.1 (06-2001)

EN 300 330-1V1.3.2 (12-2002)

EMC: EN 301 489-3V1.4.1 (08-2002)

EN 301 489-1V1.5.1 (11-2004)

Safety: EN 61010-1: 2001 (2nd Edition)



| | |
|-------------------|---|
| English | Hereby, Omron, declares that the RFID System, V680-HS52 Series, V680-HS63 Series, and V680-HA63A Series are in compliance with the essential requirements and other relevant provisions of Directive 1999/5/EC. |
| Finnish | Omron vakuuttaa täten että RFID Säännös, V680-HS52 Series, V680-HS63 Series, V680-HA63A Series tyyppinen laite on direktiivin 1999/5/EY oleellisten vaatimusten ja sitä koskevien direktiivin muiden ehtojen mukainen. |
| Dutch | Hierbij verklaart Omron dat het toestel de RFID Systeem, V680-HS52 'Serie, V680-HS63 'Serie, V680-HA63A 'Serie in overeenstemming is met de essentiële eisen en de andere relevante bepalingen van richtlijn 1999/5/EG. |
| French | Par la présente Omron déclare que la RFID Système, V680-HS52 Série, V680-HS63 Série, V680-HA63A Série sont conforme aux exigences essentielles et aux autres dispositions pertinentes de la directive 1999/5/CE. |
| Swedish | Härmed intygar Omron att den RFID System, V680-HS52 Serie, V680-HS63 Serie, V680-HA63A Serie står i överensstämmelse med de väsentliga egen-skapskrav och övriga relevanta bestämmelser som framgår av direktiv 1999/5/EG. |
| Danish | Undertegnede Omron erklærer herved, at følgende den RFID System, V680-HS52 Serie, V680-HS63 Serie, 680-HA63A Serie overholder de væsentlige krav og øvrige relevante krav i direktiv 1999/5/EF. |
| German | Hiermit erkläre Omron, die RFID System, V670-H11 Serie, V680-HS63 Serie, V680-HA63A Serie in Übereinstimmung mit den grundlegenden Anforderungen und den anderen relevanten Vorschriften der Richtlinie 1999/5/EG befindet. (BMW) |
| Greek | ΜΕ ΤΗΝ ΠΑΡΟΥΣΑ ΟΜΡΟΝ ΔΗΛΩΝΕΙ ΡFID ΟΥΟΓΗΜΑ, V680-HS52 ΟΕΙΡΑ, V680-HS63 ΟΕΙΡΑ, V680-HA63A ΟΕΙΡΑ ΣΥΜΜΟΡΦ ΟΝΕΤΑΙ ΠΡΟΣ ΤΙΣ ΟΥΣΙΟΔΕΙΣ ΑΠΑΙΤΗΣΕΙΣ ΚΑΙ ΤΙΣ ΛΟΙΠΕΣ ΣΧΕΤΙΚΕΣ ΔΙΑΤΑΞΕΙΣ ΤΗΣ ΟΑΗΓΙΑΣ 1999/5/ΕΚ. |
| Italian | Con la presente Omron dichiara che la RFID Sistema, V680-HS52 Serie, V680-HS63 Serie, V680-HA63A Serie sono conforme ai requisiti essenziali ed alle altre disposizioni pertinenti stabilite dalla direttiva 1999/5/CE. |
| Spanish | Por medio de la presente Omron declara que el RFID Sistema, V680-HS52 Serie, V680-HS63 Serie, V680-HA63A Serie esta conforme a los requisitos esenciales y cualesquiera otras disposiciones aplicables o exigibles de la Directiva 1999/5/CE. |
| Portuguese | Omron declara que a RFID Sistema, V680-HS52 Série, V680-HS63 Série, V680-HA63A Série ser conforme com os requisitos essenciais e outras disposições da Directiva 1999/5/CE. |
| Romanian | Prin prezenta, Omron declară că acest V680-HS52, V680-HS63, V680-HA63A este conform cu cerințele principale și cu celelalte prevederi relevante ale Directivei 1999/5/EC. |

Changes or modifications not expressly approved by the party responsible for compliance could void the user's authority to operate the equipment.

Do not remove the ferrite core (TDK Type ZCAT1730-0730A) installed on the cables to suppress RF interference.

3. Japan Radio Law

Equipment using high frequencies: Inductive Reading/Writing Communications Equipment

Conforming standards: Inductive Reading/Writing Communications Equipment; Standard: ARIB STD-T82

Precautions for Safe Use

Be sure to observe the following precautions to ensure safe use of the Products.

1. Do not use the Products in environments with flammable, explosive, or corrosive gasses.
2. Do not attempt to disassemble, repair, or modify any Product.
3. Tighten mounting screws securely.
4. If any cable has a locking mechanism, make sure that it has been locked before using the cable.
5. Do not allow water or pieces of wire to enter from openings in the case. Doing so may cause fire or electric shock.
6. Turn OFF the Controller power supply before mounting or removing an Antenna or Amplifier.
7. If an error is detected in any Product, immediately stop operation and turn OFF the power supply. Consult with an OMRON representative.
8. Dispose of the Products as industrial waste.
9. Observe all warnings and precautions given in the body of this manual.
10. Do not touch the product immediately after usage at high temperatures. Doing so may occasionally result in burning.

Precautions for Correct Use

Always observe the following precautions to prevent operation failures, malfunctions, and adverse effects on performance and equipment.

1. Installation Environment

Do not use the Products in the following locations.

- Locations exposed to corrosive gases, dust, metallic powder, or salts
- Locations not within the specified operating temperature range
- Locations subject to rapid changes in temperature or condensation
- Locations not within the specified humidity range
- Locations subject to direct vibration or shock outside the specified ranges
- Locations subject to spray of water, oil, or chemicals

2. Installation

The Products communicate with Tags using the 13.56-MHz frequency band. Some motors, inverters, and switching power supplies generate noise that can affect communications with the Tags and cause errors. If such devices are located near the Tags, always test operation in advance to confirm whether the system will be affected.

- Observe the following precautions to minimize the effects of normal noise.
 - (1) Ground all metal objects in the vicinity of the Products to 100 Ω or less.
 - (2) Do not use the Products near high-voltage or high-current lines.
- Do not use non-waterproof Products in an environment where mist is present.
- Do not expose the Products to chemicals that adversely affect the Product materials.
- When mounting the Products, tighten the screws to the following torques.
 - V680-HS63: 1.2 N·m
 - V680-HS52: 40 N·m
- If multiple Antennas are mounted near each other, communications performance may decrease due to mutual interference. Refer to *Installing Antennas on page 32* and check to make sure there is no mutual interference.
- Depending on the operating environment, the case surface may become fogged, but basic performance will not be affected.

3. Storage

Do not store the Products in the following locations.

- Locations exposed to corrosive gases, dust, metallic powder, or salts
- Locations not within the specified storage temperature range
- Locations subject to rapid changes in temperature or condensation
- Locations not within the specified storage humidity range
- Locations subject to direct vibration or shock outside the specified ranges
- Locations subject to spray of water, oil, or chemicals

4. Cleaning

- Do not clean the Products with paint thinner or the equivalent. Paint thinner or the equivalent will dissolve the resin materials and case coating.

Meanings of Symbols



CHECK!

Indicates particularly important points related to a function, including precautions and application advice.



Indicates page numbers containing relevant information.

Table of Contents

| | |
|---|-----------|
| Safety Precautions | 3 |
| Regulations and Standards | 3 |
| Precautions for Safe Use | 5 |
| Precautions for Correct Use | 6 |
| Meanings of Symbols | 7 |
| Table of Contents | 9 |
| Section 1 Product Overview | 11 |
| Features | 12 |
| Product Configuration | 13 |
| Section 2 Specifications and Performance | 15 |
| Antennas with Separate Amplifier | 16 |
| Amplifier | 20 |
| Tags | 23 |
| Section 3 Communications Specifications | 27 |
| Communications Distances | 28 |
| Section 4 Installation | 31 |
| Installing Antennas | 32 |
| Mounting Amplifiers | 33 |
| Installing Tags | 37 |
| Section 5 Chemical Resistance | 39 |
| Chemical Resistance of the Antennas | 40 |
| Chemical Resistance of Tags | 41 |
| Revision History | 44 |

Section 1

Product Overview

| | |
|-------------------------|----|
| ▣ Features | 12 |
| ▣ Product Configuration | 13 |

Features

The V680-series RFID System actively supports many different types of system, such as distributed-control systems and many-product, small-lot production systems, with non-contact data communications using electromagnetic induction.

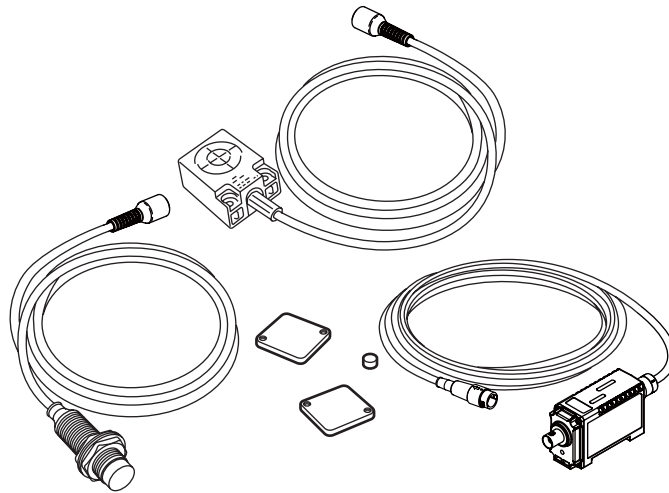

■ Non-contact Data Communications

The V680 Series uses electromagnetic induction to enable non-contact, bi-directional data communications between Antennas and Tags.

■ EEPROM Memory

EEPROM (non-volatile memory) is used for Tag memory. No battery is required, so there is no need to be concerned about battery service life.

■ CRC Used for Transmission Error Detection

A bi-directional 16-bit CRC (Cyclic Redundancy Check) has been added as the error detection method for wire transmissions between ID Controllers and Antennas, and for wireless transmissions between Antennas and Tags. This method maintains superior communications reliability even where problems such as noise occur.

■ One Kilobyte of Memory

Tags have one kilobyte of memory. In addition to the ID data required on-site, data such as model numbers and inspection information can be input.

■ Long Service Life of 100,000 Data Rewrites at Normal Temperatures

When the Tag is used at temperatures of up to 25°C, each bit of EEPROM data can be rewritten up to 100,000 times.

■ Superior Environmental Resistance and High Reliability

Antennas and Tags now have greater environmental resistance and are not affected by vibration, oil, or water.

Product Configuration

A V680-series RFID System consists of an ID Controller, one or more Amplifiers, one or two Antennas, and Tags. Select the models suitable for the application.

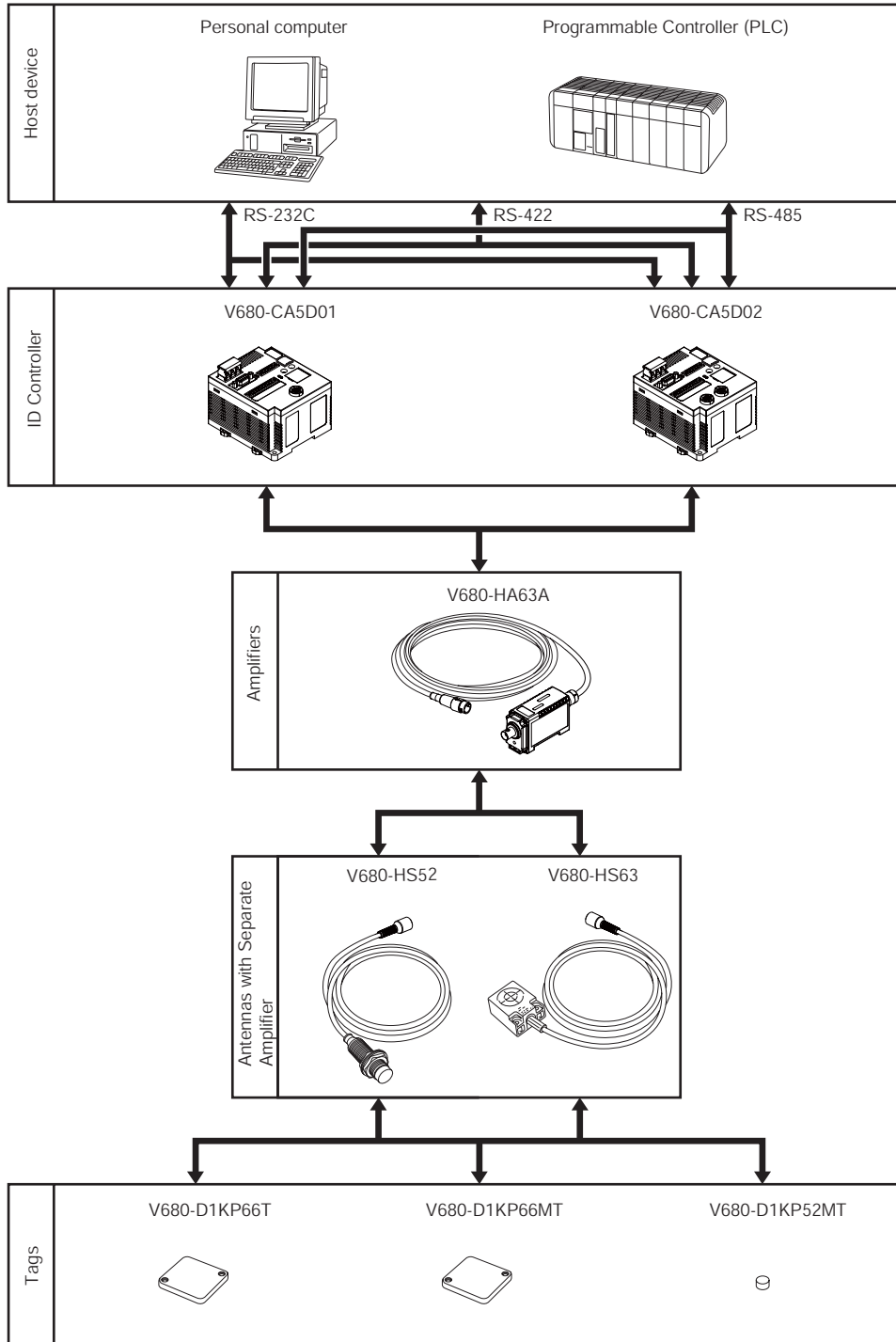

MEMO

Section 2

Specifications and Performance

| | |
|------------------------------------|----|
| ☒ Antennas with Separate Amplifier | 16 |
| ☒ Amplifier | 20 |
| ☒ Tags | 23 |

Antennas with Separate Amplifier

V680-HS63

General Specifications

| Item | Model | V680-HS63-W (Standard cable, waterproof connector) | V680-HS63-R (Flexible cable, non-waterproof connector) |
|-------------------------------|-------|--|---|
| Ambient operating temperature | | -10 to 60°C (with no icing) | |
| Ambient storage temperature | | -25 to 75°C (with no icing) | |
| Ambient operating humidity | | 35% to 95% (with no condensation) | |
| Insulation resistance | | 20 MΩ min. (at 500 VDC) between cable terminals and case | |
| Dielectric strength | | 1,000 VAC, 50/60Hz for 1 min between cable terminals and case | |
| Degree of protection | | IP67G (Head) Note: The connector specifications are IP67 and IP65. | IP67G (Head) Note: The connectors are not waterproof. |
| Vibration resistance | | 10 to 500 Hz, 1.5-mm double amplitude, acceleration: 100 m/s ² , 10 sweeps in each of 3 axis directions (up/down, left/right, and forward/backward) for 11 minutes each | |
| Shock resistance | | 500 m/s ² , 3 times each in 6 directions (Total: 18 times) | |
| Dimensions | | 40 × 53 × 23 mm | |
| Material | | ABS resin case, epoxy resin filler | |
| Weight | | Approx. 850 g (with 12.5 m cable) | |
| Cable length | | Standard lengths of 2 and 12.5 m | |

Dimensions

V680-HS63-W

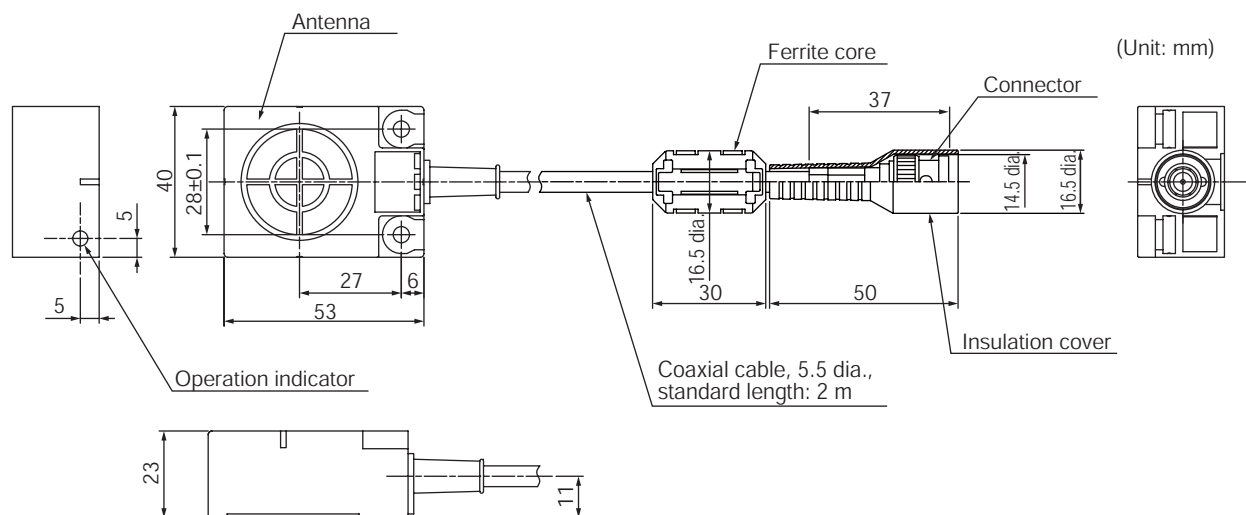

Note: Mounting Hole Dimensions

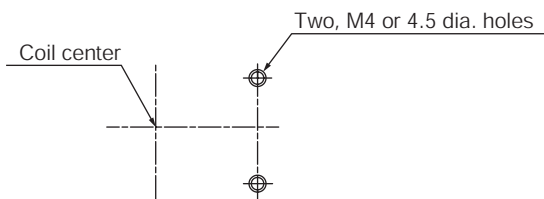

| | |
|---------------|-------------|
| Case material | ABS resin |
| Fill resin | Epoxy resin |
| Cable | PVC (gray) |

• V680-HS63-R

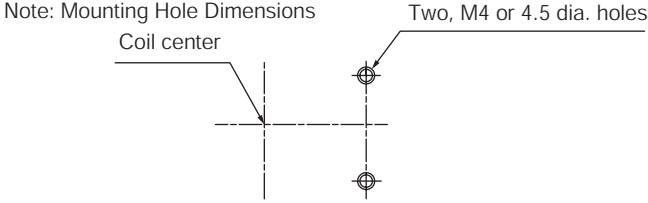
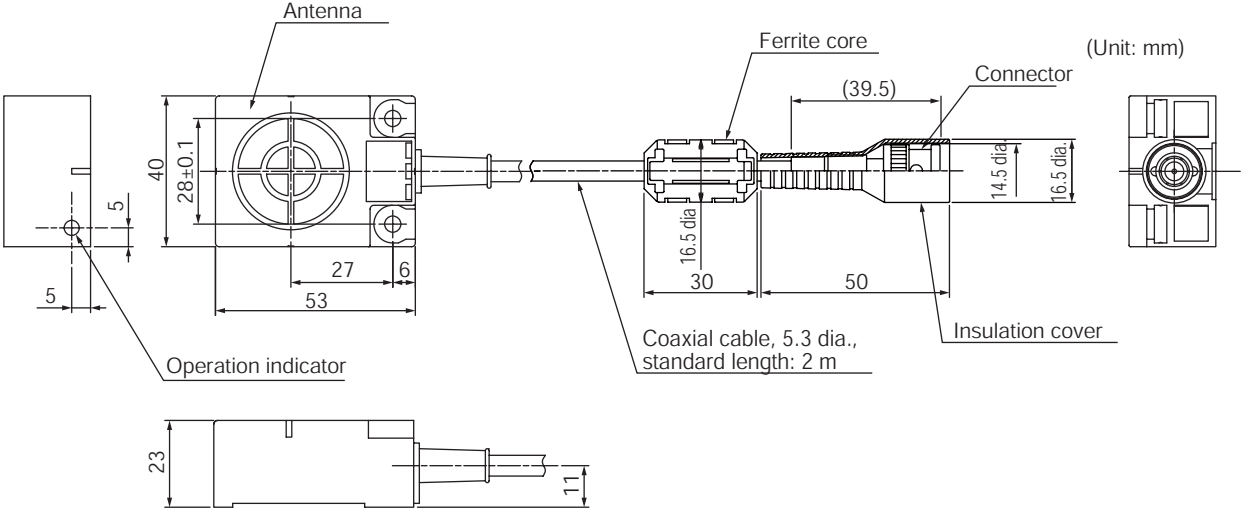

| | |
|---------------|-------------|
| Case material | ABS resin |
| Fill resin | Epoxy resin |
| Cable | PVC (black) |

V680-HS52

General Specifications

| Item | Model | V680-HS52-W (Standard cable, waterproof connector) | V680-HS52-R (Flexible cable, non-waterproof connector) |
|-------------------------------|-------|---|---|
| Ambient operating temperature | | -10 to 60°C (with no icing) | |
| Ambient storage temperature | | -25 to 75°C (with no icing) | |
| Ambient operating humidity | | 35% to 95% (with no condensation) | |
| Insulation resistance | | 20 MΩ min. (at 500 VDC) between connector terminals and case | |
| Dielectric strength | | 1,000 VAC, 50/60 Hz for 1 min between connector terminals and case | |
| Degree of protection | | IP67G (Head) Note: The connector specifications are IP67 and IP65. | IP67G (Head) Note: The connectors are not waterproof. |
| Dielectric strength | | 10 to 500 Hz, 1.5-mm double amplitude, acceleration: 100 m/s ² , 10 sweeps in each of 3 axis directions (up/down, left/right, and forward/backward) for 8 minutes each | |
| Shock resistance | | 500 m/s ² , 3 times each in 6 directions (Total: 18 times) | |
| Dimensions | | M22 × 65 mm | |
| Material | | ABS resin, brass, and epoxy resin filler | |
| Weight | | Approx. 850 g (with 12.5 m cable) | |
| Cable length | | Standard lengths of 2 and 12.5 m | |

Dimensions

• V680-HS52-W

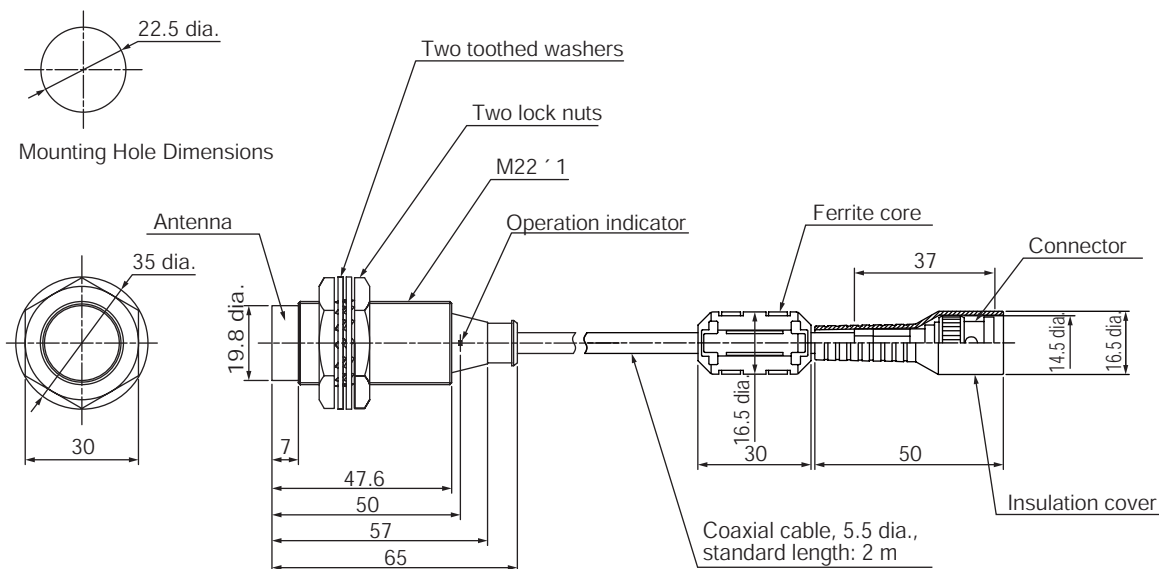

| | |
|------------------------|-------------|
| Case material | Brass |
| Communications surface | ABS resin |
| Fill resin | Epoxy resin |
| Cable | PVC (gray) |

• V680-HS52-R

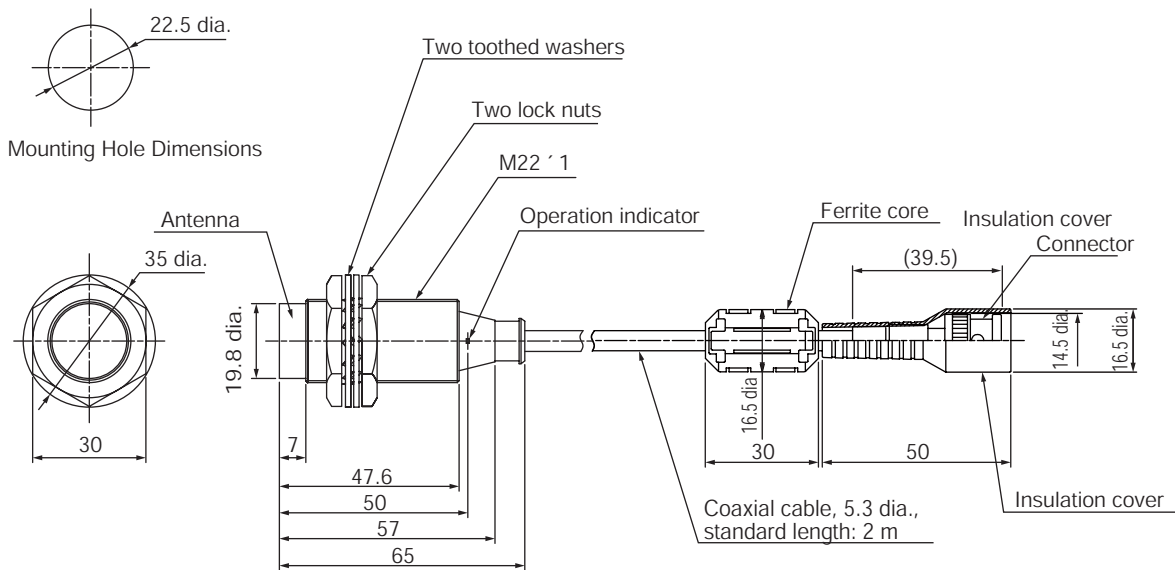

| | |
|------------------------|-------------|
| Case material | Brass |
| Communications surface | ABS resin |
| Fill resin | Epoxy resin |
| Cable | PVC (black) |

Amplifier

V680-HA63A

General Specifications

| Item | Model | V680-HA63A |
|-------------------------------|-------|--|
| Ambient operating temperature | | -10 to 55°C (with no icing) |
| Ambient storage temperature | | -25 to 65°C (with no icing) |
| Ambient operating humidity | | 35% to 85% (with no condensation) |
| Insulation resistance | | 20 MΩ min. (at 500 VDC) between cable terminals and case |
| Dielectric strength | | 1,000 VAC, 50/60 Hz for 1 minute between cable terminals and case. |
| Degree of protection | | IP67, IP65 (IEC 60529) Note: Not including connector at Controller end. (When V680-HS63-W or V680-HS52-W is connected) |
| | | IP40 (IEC 60529) (When V680-HS63-R or V680-HS52-R is connected) |
| Dielectric strength | | Destruction: 10 to 500 Hz, 1.5-mm double amplitude, acceleration:100 m/s ² , 10 sweeps in each of 3 axis directions (up/down, left/right, and forward/backward) for 11 minutes each |
| Shock resistance | | Destruction: 500 m/s ² , 3 times each in 6 directions (Total: 18 times) |
| Dimensions | | 25 × 40 × 65 mm (Not including protrusions.) |
| Materials | | PC |
| Weight | | Approx. 850 g (with 10 m cable) |
| Cable length | | Standard lengths of 5 and 10 m |

Note: The maximum total cable extension is 50 m (including the Amplifier cable). A maximum of two extension cables can be connected.

Dimensions

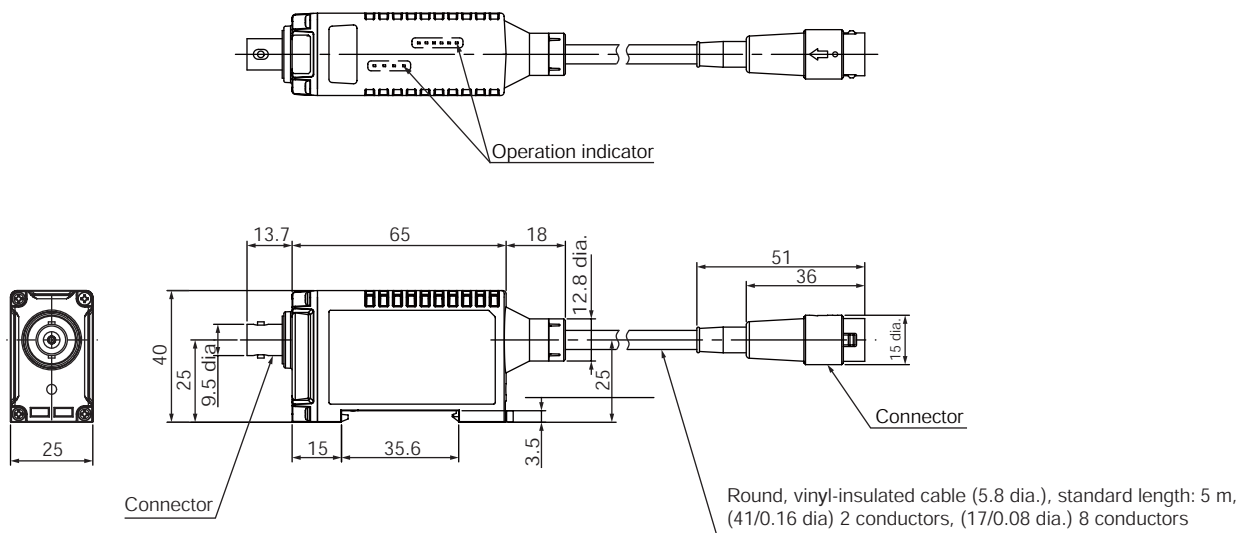

| | |
|---------------|----------|
| Case material | PC resin |
| Cable | PVC |

Nomenclature

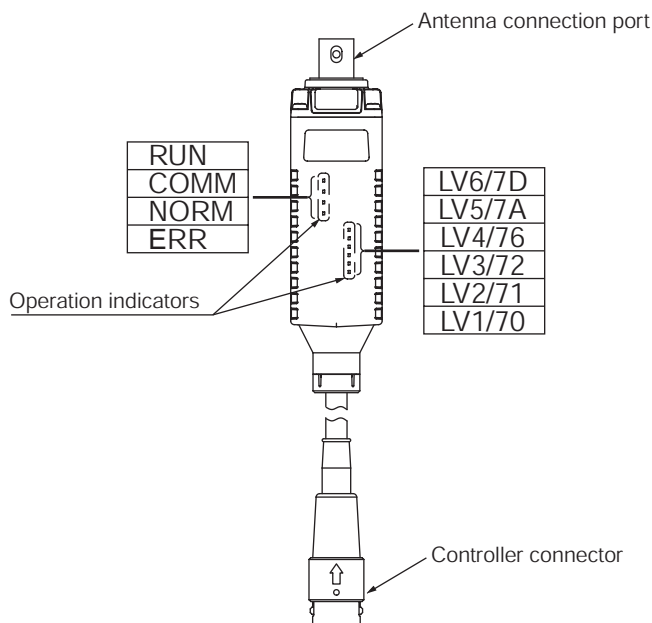

■ Antenna Connection Port

The Antenna connection port is connected a V680-series Antenna.

■ Controller Connector

The Controller connector is connected to Antenna connection port on the Controller.

■ Operation Indicators (LEDs)

| Name | Color | Meaning |
|--------|--------|--|
| RUN | Green | Lit when the power is ON. |
| COMM | Yellow | Lit when a command is being sent. |
| NORM | Green | Lit when communications with a Tag are normal in Normal Communications Mode. |
| ERR | Red | Lit when an error occurs in communications with a Tag in Normal Communications Mode. |
| LV6/7D | Yellow | Maintenance Mode: Lit at distance or speed level 6. Normal Communications Mode: Lit when a write protection error occurs. |
| LV5/7A | Yellow | Maintenance Mode: Lit at distance or speed level 5 or higher. Normal Communications Mode: Lit when an address error occurs. |
| LV4/76 | Yellow | Maintenance Mode: Lit at distance or speed level 4 or higher. Normal Communications Mode: Lit when a Tag memory error occurs. |
| LV3/72 | Yellow | Maintenance Mode: Lit at distance or speed level 3 or higher. Normal Communications Mode: Lit when a no Tag error occurs. |
| LV2/71 | Yellow | Maintenance Mode: Lit at distance or speed level 2 or higher. Normal Communications Mode: Lit when a verification error occurs. |
| LV1/70 | Yellow | Maintenance Mode: Lit at distance or speed level 1 or higher. Normal Communications Mode: Lit when a Tag communications error occurs. |

Cables

Specifications

| Item | Model | V700-A43/V700-A44 |
|-----------------------|-------|---|
| Number of conductors | | 10 |
| Insulation resistance | | 5 MΩ min. (at 500 VDC) between terminals and sheath |
| Dielectric strength | | 500 VAC, 1 min |

Dimensions

| Item | Model | V700-A43 | V700-A44 |
|-------------|-------|---------------|-----------------|
| Length (L1) | | Approx. 10m | Approx. 20 m |
| Weight | | Approx. 700 g | Approx. 1,350 g |

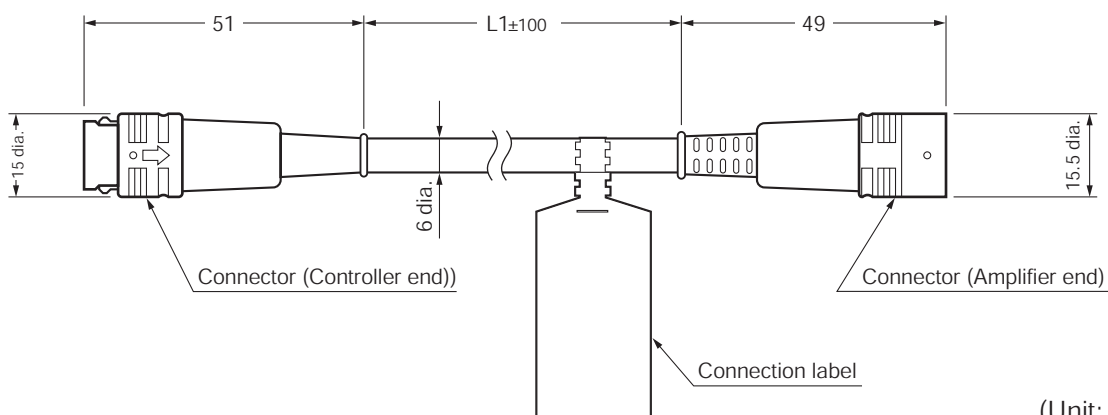

| | |
|-----------------|-----|
| Casing material | PVC |
|-----------------|-----|

Tags

Specifications and Dimensions

■ V680-D1KP52MT

• General Specifications

| Item | Model | 680-D1KP52MT |
|--|-------|---|
| Memory capacity | | 1,000 bytes (user area) |
| Memory type | | EEPROM |
| Data backup time | | 10 years after writing |
| Data overwrite count | | 100,000 times per address (25°C) |
| Ambient operating temperature when communicating | | -25 to 85°C (with no icing) |
| Ambient operating temperature when not communicating | | -40 to 125°C (with no icing) Heat resistance (See note.): Thermal cycle of -10 and 150°C for 1,000 cycles of 30 min each High-temperature storage: 1,000 hours at 150°C |
| Ambient storage temperature | | -40 to 125°C (with no icing) |
| Ambient operating humidity | | 35% to 95% |
| Degree of protection | | IP68 (IEC 60529) IP67G (JEM standards) |
| Vibration resistance | | Destruction: 10 to 2,000 Hz, 1.5-mm double amplitude, acceleration: 150 m/s ² , 10 sweeps each in X, Y, and Z directions for 15 minutes each |
| Shock resistance | | Destruction: 500 m/s ² , 3 times each in X, Y, and Z directions (Total: 18 times) |
| Dimensions | | 8 dia. × 5 mm |
| Materials | | Case: PPS resin, Fill resin: Epoxy resin |
| Weight | | Approx. 0.5 g |
| Metal countermeasures | | Yes |

Note: For heat resistance at 150°C, the Tags were left standing at 150°C for 1,000 hours and then subjected to thermal shock for 1,000 cycles of 30 minutes each at -10 and 150°C. (There were no failures in 22 samples.)

• Dimensions

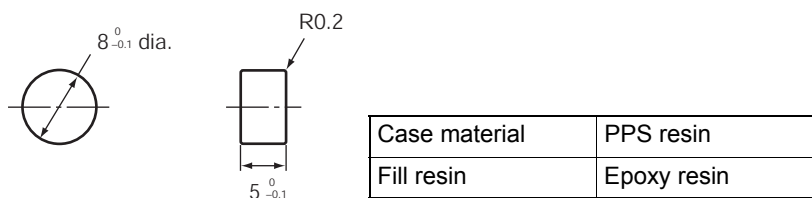

■ V680-D1KP66T/MT

• General Specifications

| Item | Model | V680-D1KP66T | V680-D1KP66MT |
|--|-------|---|---------------|
| Memory capacity | | 1,000 bytes (user area) | |
| Memory type | | EEPROM | |
| Data backup time | | 10 years after writing | |
| Data overwrite count | | 100,000 times per address (25°C) | |
| Ambient operating temperature when communicating | | -25 to 85°C (with no icing) | |
| Ambient operating temperature when not communicating | | -40 to 125°C (with no icing) Heat resistance (See note.): Thermal cycle of -10 and 150°C for 1,000 cycles of 30 min each High-temperature storage: 1,000 hours at 150°C | |
| Ambient storage temperature | | -40 to 125°C (with no icing) | |
| Ambient operating humidity | | 35% to 95% | |
| Degree of protection | | IP68 (IEC 60529) IP67G (JEM standards) | |
| Vibration resistance | | Destruction: 10 to 2,000 Hz, 1.5-mm double amplitude, acceleration: 150 m/s ² , 10 sweeps each in X, Y, and Z directions for 15 minutes each | |
| Shock resistance | | Destruction: 500 m/s ² , 3 times each in X, Y, and Z directions (Total: 18 times) | |
| Dimensions | | 34 × 34 × 3.5 mm | |
| Materials | | Case: PPS resin | |
| Weight | | Approx. 6 g | Approx. 7.5 g |
| Metal countermeasures | | None | Yes |

Note: For heat resistance at 150°C, Tags were left standing at 150°C for 1,000 hours and also subjected to thermal shock for 1,000 cycles of 30 minutes each at -10°C and 150°C. (There were no failures in 22 samples.)

The V680-D1KP66MT is designed to be mounted directly to metal. The V680-D1KP66T and V680-D1KP66MT markings are shown in the following diagrams.

● V680-D1KP66MT



● V680-D1KP66T

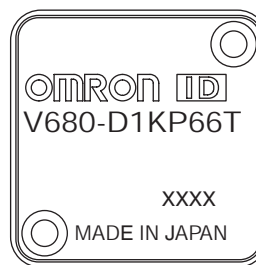

The side with the markings is the communications surface. Mount the Tag with this side facing the Antenna.

• Dimensions

V680-D1KP66T/MT

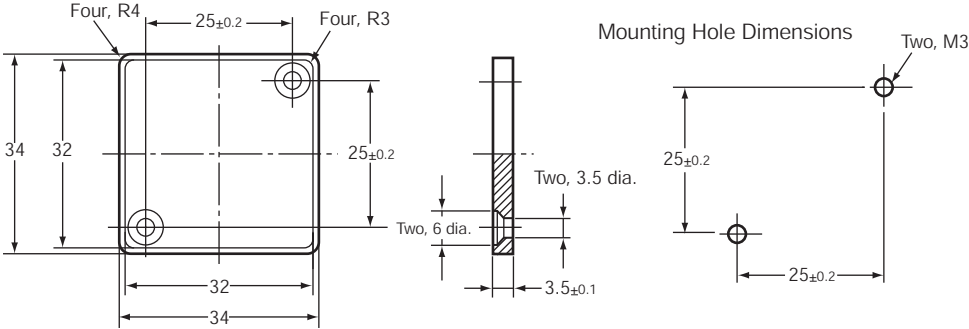

| | |
|---------------|-----------|
| Case material | PPS resin |
|---------------|-----------|

V600-A86 Attachment

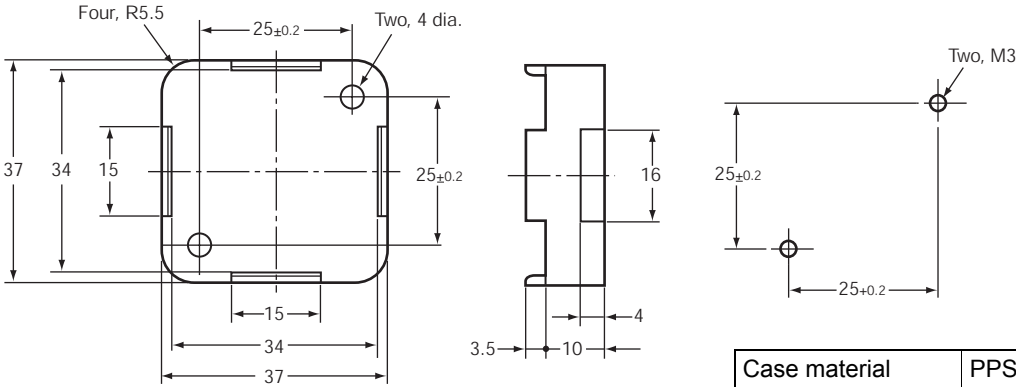

| | |
|---------------|-----------|
| Case material | PPS resin |
|---------------|-----------|

MEMO

Section 3

Communications Specifications

 Communications Distances

28

Communications Distances

V680-D1KP52MT

■ Communications Distance Specifications (Certified Performance)

| Amplifier | Antenna | ID Tag | Communications distance | |
|------------|-----------|---|-------------------------|--------------------------------------|
| V680-HA63A | V680-HS52 | V680-D1KP52MT | Read | 0 to 9.0 mm (Axis offset: ± 2) |
| | | | Write | 0 to 8.5 mm (Axis offset: ± 2) |
| | V680-HS52 | V680-D1KP52MT embedded in metal (steel) | Read | 0 to 4.5 mm (Axis offset: ± 2) |
| | | | Write | 0 to 4.0 mm (Axis offset: ± 2) |
| | V680-HS63 | V680-D1KP52MT | Read | 0 to 12.0 mm (Axis offset: ± 2) |
| | | | Write | 0 to 9.5 mm (Axis offset: ± 2) |

• Measurement Conditions

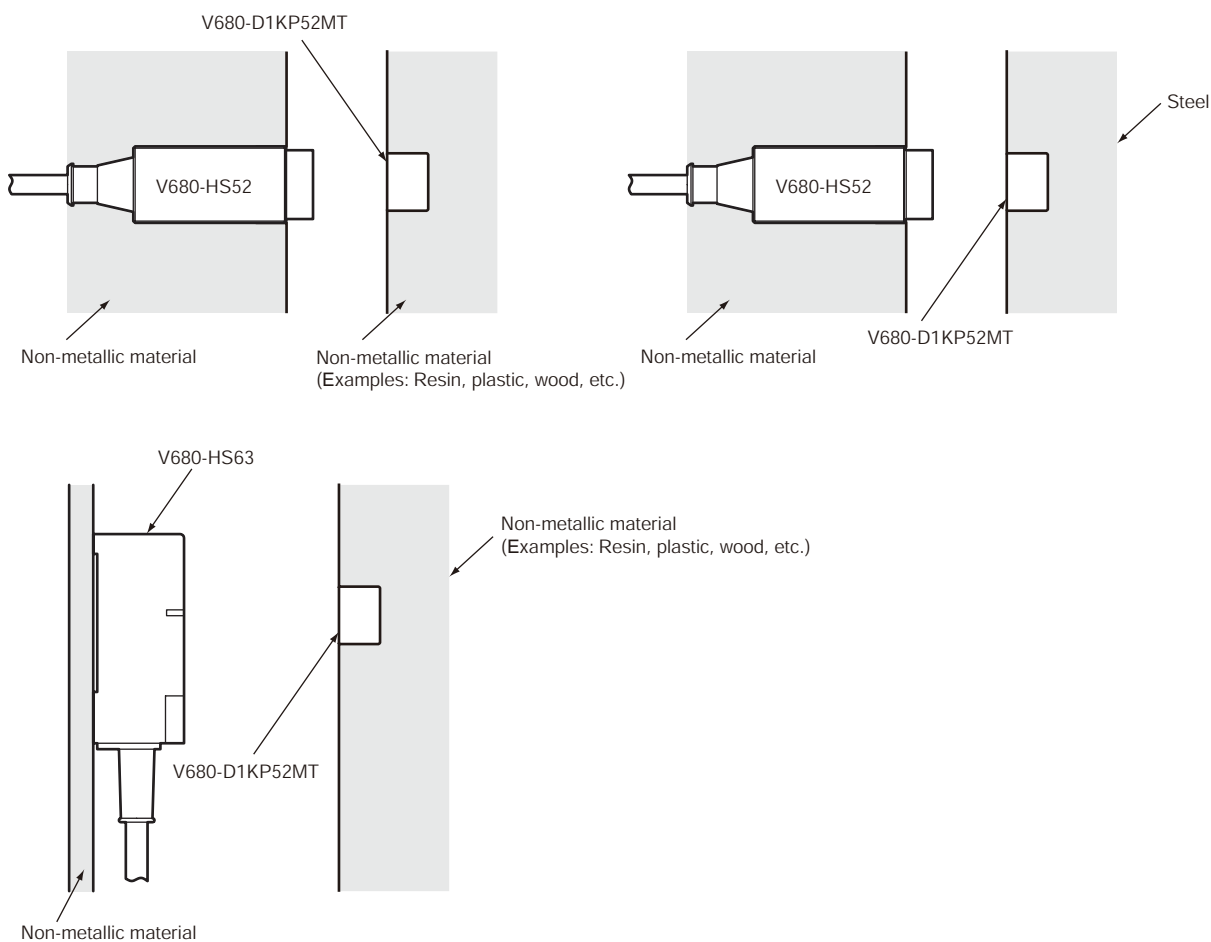

V680-D1KP66T

■ Communications Distance Specifications (Certified Performance)

| Amplifier | Antenna | ID Tag | Communications distance | |
|------------|-----------|--------------|-------------------------|---------------------------------|
| V680-HA63A | V680-HS52 | V680-D1KP66T | Read | 0 to 17.0 mm (Axis offset: ±2) |
| | | | Write | 0 to 17.0 mm (Axis offset: ±2) |
| | V680-HS63 | V680-D1KP66T | Read | 0 to 30.0 mm (Axis offset: ±10) |
| | | | Write | 0 to 25.0 mm (Axis offset: ±10) |

• Measurement Conditions

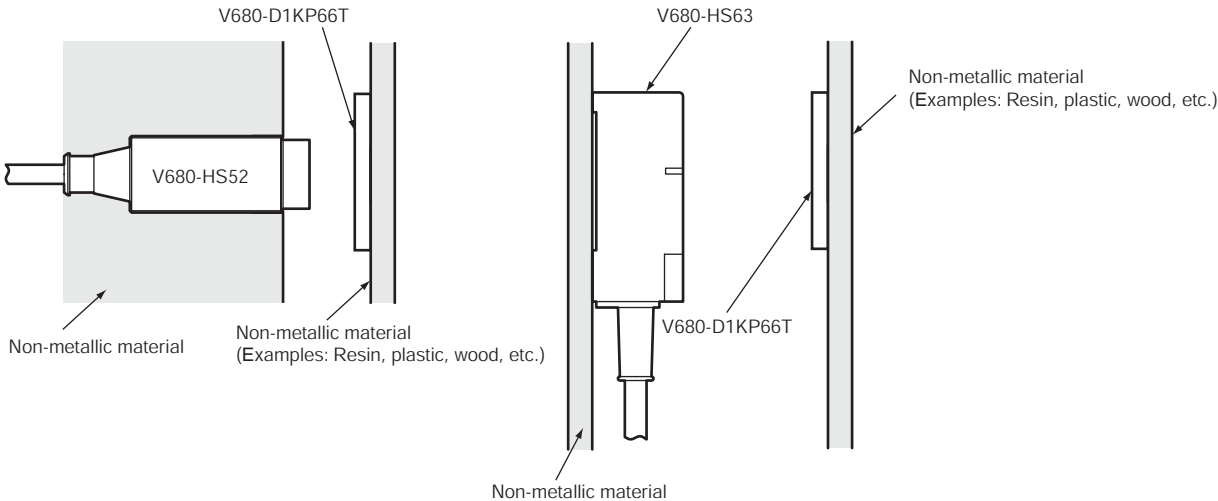

V680-D1KP66MT

■ Communications Distance Specifications (Certified Performance)

| Amplifier | Antenna | ID Tag | Communications Distance | |
|------------|-----------|---|-------------------------|---------------------------------------|
| V680-HA63A | V680-HS52 | V680-D1KP66MT with metal on back surface (steel) | Read | 0 to 16.0 mm (Axis offset: ± 2) |
| | | | Write | 0 to 14.0 mm (Axis offset: ± 2) |
| | V680-HS63 | V680-D1KP66MT with metal on back surface (steel) | Read | 0 to 25.0 mm (Axis offset: ± 10) |
| | | | Write | 0 to 20.0 mm (Axis offset: ± 10) |

• Measurement Conditions

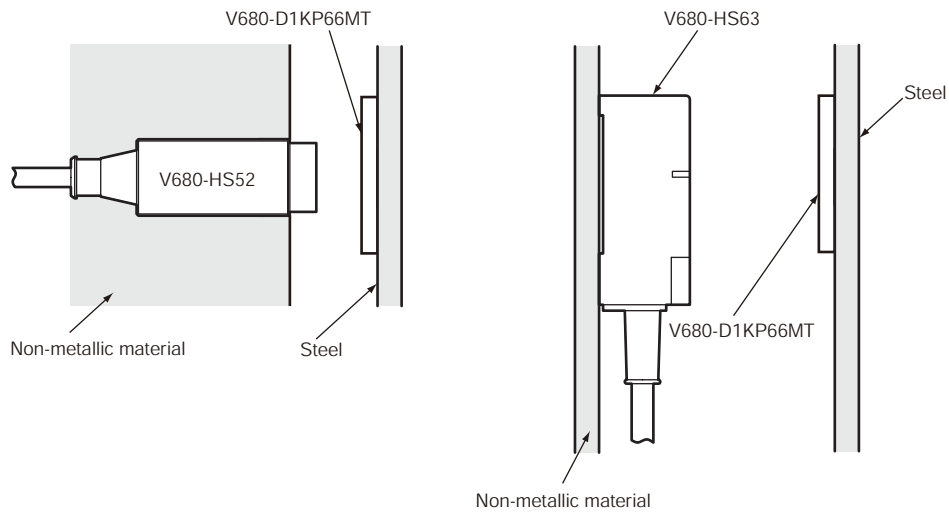

Section 4 Installation

| | |
|-----------------------|----|
| ☒ Installing Antennas | 32 |
| ☒ Mounting Amplifiers | 33 |
| ☒ Installing Tags | 37 |

Installing Antennas

V680-HS63

Installation from the Front

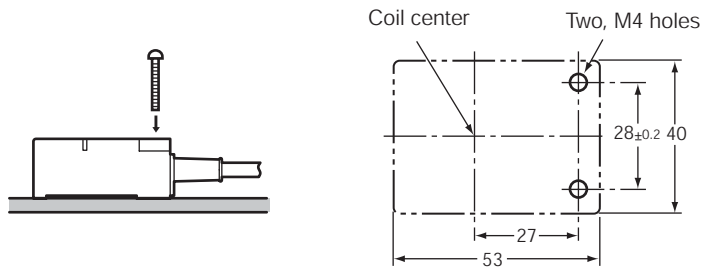

Installation from the Back

Insert the nuts that come with the Antenna into sections A.

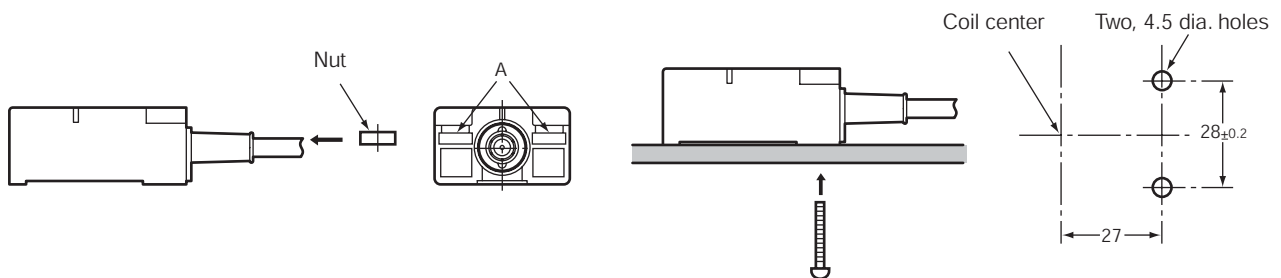

Securely tighten screws to a maximum torque of 1.2 N-m.

CHECK!

V680-HS52

Install the Antenna using the nuts and toothed washers that are provided on both sides of the mounting material, as shown in the diagram below.



When the Antenna is mounted to a metal object, the communications distance will be reduced by approximately 10% compared with mounting to a non-metallic object. For details on the effect of metal surrounding the Antenna, refer to *Effect of Surrounding Metals on the Antenna (Reference)* on page 35.

CHECK!



P.35

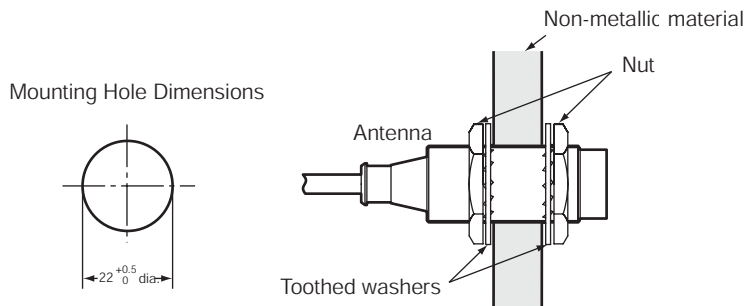

Securely tighten the screws to a maximum torque of 40 N-m.

CHECK!

Mounting Amplifiers

V680-HA63A

■ Mounting to DIN Track

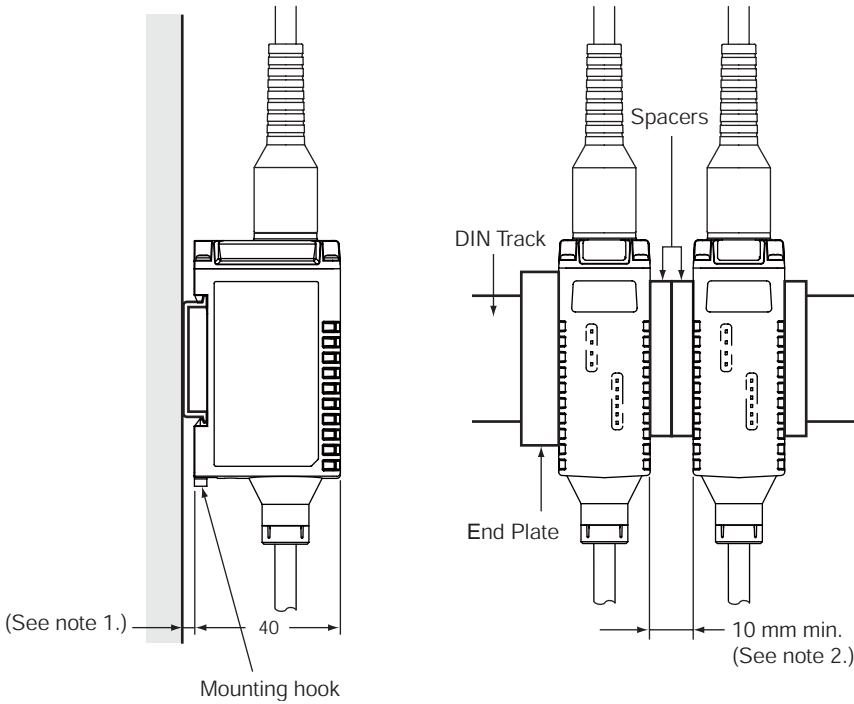

- Note** 1. Consider the height of the DIN Track.
 2. Provide a space of at least 10 mm (i.e., at least two spacers) and attach them securely.

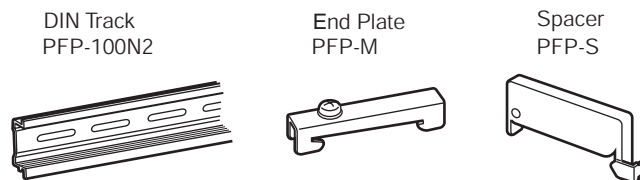
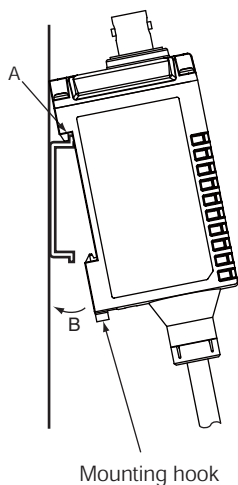

1. When mounting the Amplifier to a DIN Track, first hook section A to the Track and then press in direction B.
2. To remove the Amplifier from the DIN Track, first pull out the mounting hook.

Amplifier Cable Bending Radius

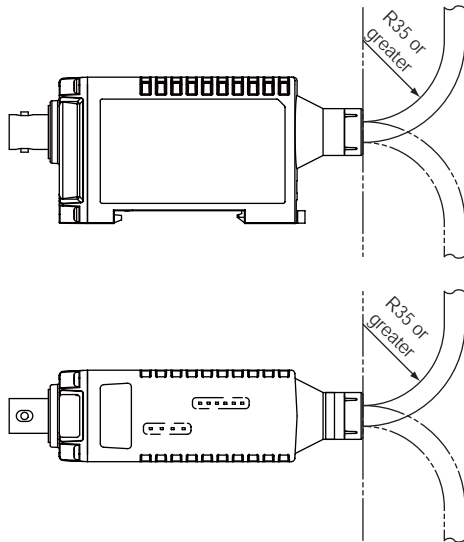

Do not bend the cable past a bending radius of 35 mm.

Attaching/Removing V680-HA63A/-HS63/-HS52 Connectors

■ Attaching the Connector

1. Hold the Antenna connector, align the key, and insert the connector into the Amplifier connector.
2. Turn the connector clockwise to lock it in place.

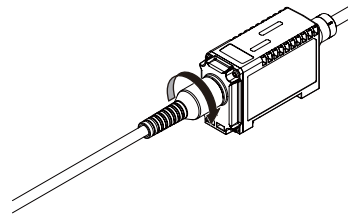
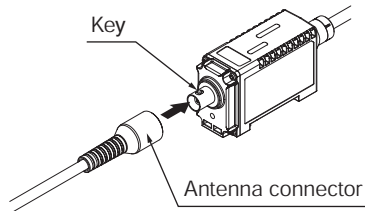

■ Removing the Connector

1. Turn the connector counterclockwise to release the lock.
2. Pull the Antenna connector straight out.

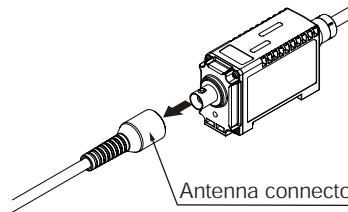
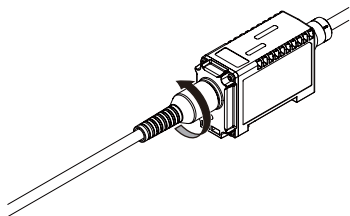

CHECK!

The connector will not come out unless the lock is first released by turning the connector. To remove the cable, release the lock and pull on the connector. Pulling the cable without releasing the lock may break or damage the cable.

Effect of Surrounding Metals on the Antenna (Reference)

■ V680-HS63

In addition to surface mounting, it is also possible to embed the V680-HS63 in a metal casing to protect it from being struck by other objects. To prevent malfunctioning, allow a space of at least 30 mm between the Antenna and the sides of the metal casing. If the space is less than 30 mm, the read/write distance will be greatly diminished. In addition, the height of metal casing must not exceed that of the Antenna.

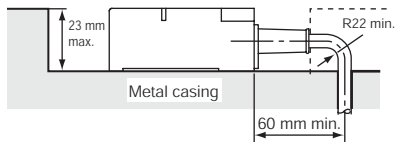

- Note**
1. Do not bend the cable into a curve tighter than 22 mm in radius.
 2. The communications distance will be reduced significantly if the Antenna is installed closer than 30 mm to metal surfaces.

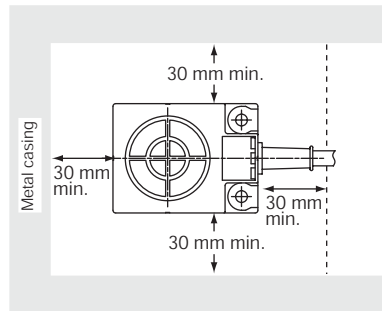

■ V680-HS52

When embedding the Antenna in metal, be sure the metal does not extend beyond the tip of the Antenna.

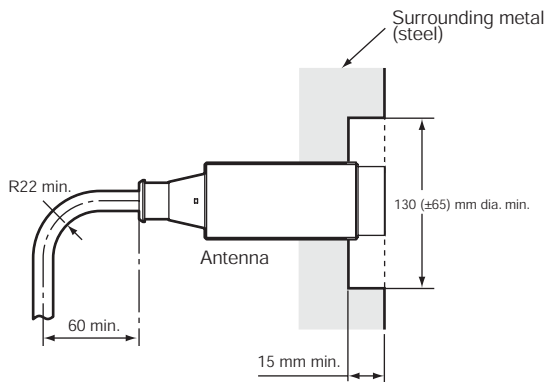

Do not bend the cable into a curve tighter than 22 mm in radius.

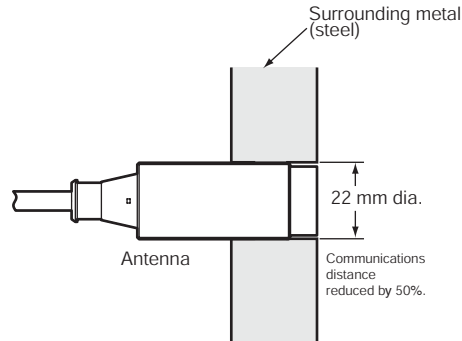

If the metal around the Antenna reaches the coil surface, the communications distance will be reduced by approximately 50% compared with mounting to a non-metallic surface.

Mutual Interference between Antennas (Reference)

To prevent malfunctioning due to mutual interference when using more than one Antenna, leave sufficient space between them as shown in the following diagrams.

■ V680-HS63

- Installing the Antennas Facing Each Other

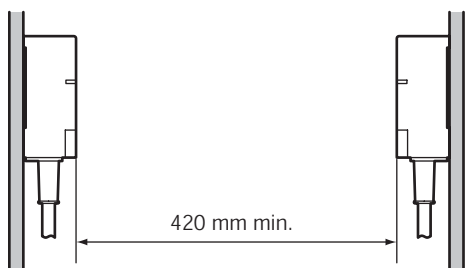

- Installing the Antennas in Parallel

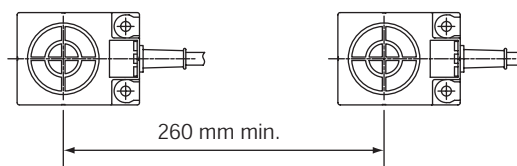

■ V680-HS52

- Installing the Antennas Facing Each Other

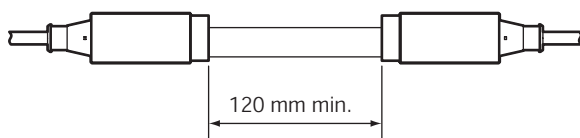

- Installing the Antennas in Parallel

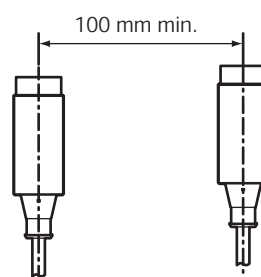

Installing Tags

V680-D1KP52MT

Mutual Interference with Tags (Reference)

Provide the mounting distances indicated below to prevent malfunctions due to mutual interference when using more than one Tag.

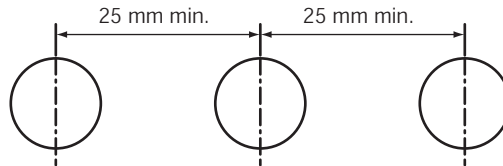

V680-D1KP66T

Tag Installation Direction

Secure the Tag with M3 screws. Tighten the screws to a torque of 0.3 to 0.5 N·m.

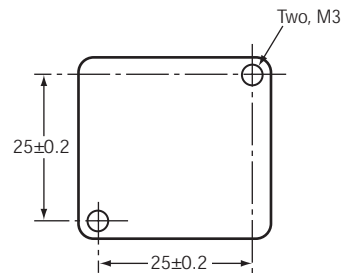

Mutual Interference with Tags (Reference)

To prevent malfunctioning due to mutual interference when using more than one Tag, leave sufficient space between them as shown in the following diagram.

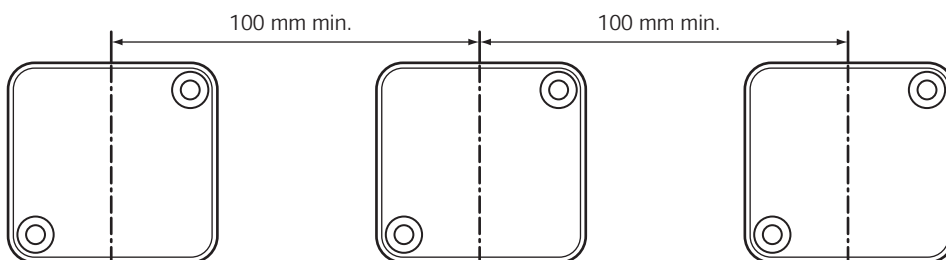

V680-D1KP66MT

■ Tag Installation Direction

Mount the V680-D1KP66MT to a metal surface, and secure the Tag with M3 screws. Tighten the screws to a torque of 0.3 to 0.5 N·m.

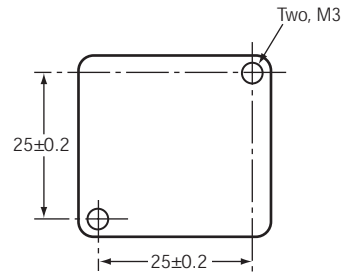

■ Mutual Interference with Tag (Reference)

To prevent malfunctioning due to mutual interference when using more than one Tag, leave sufficient space between them as shown in the following diagram.

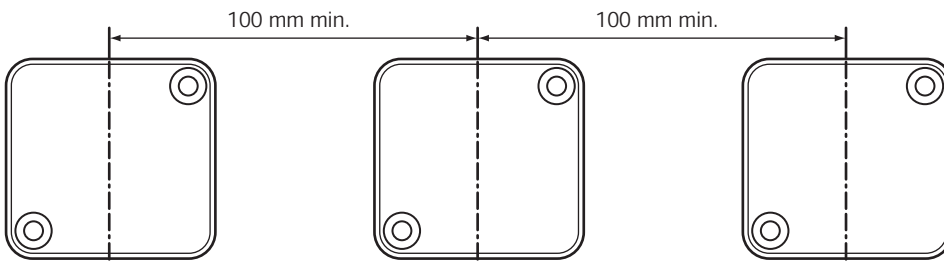

Section 5

Chemical Resistance

| | |
|---------------------------------------|----|
| ☒ Chemical Resistance of the Antennas | 40 |
| ☒ Chemical Resistance of Tags | 41 |

Chemical Resistance of the Antennas

Applicable Models

V680-HS63-W/R V680-HS52-W/R

ABS resin is used for case material and epoxy resin for filling material. Refer to the following lists and do not use chemicals that affect ABS and epoxy resin.

Chemicals That Cause Deformations, Cracks, Etc.

| ABS resin | Epoxy resin |
|--|---|
| Trichlene, acetone, xylene, toluene, gasoline, creosol, methylene chloride, phenol, cyclohexane, aqua regia, chromic acid, sulfuric acid (90% RT), methyl ethyl ketone, aniline, nitrobenzine, monochlorobenzine, pyridine, nitric acid (60% RT), formic acid (80% RT) | Aqua regia, chromic acid, sulfuric acid (90% RT), nitric acid (60% RT), ammonia solution, acetone, methylene chloride, phenol |

Chemicals That May Cause Discoloration, Swelling, Etc.

| ABS resin | Epoxy resin |
|---|--|
| Hydrochloric acid, alcohol, Freon, sodium hydroxide, hydrogen peroxide, benzene, sulfuric acid (10% RT), nitric acid (10% RT), phosphoric acid (85% RT), ammonia solution | Sulfuric acid (10% RT), nitric acid (10% RT), hydrochloric acid (30% RT), acetic acid (50% RT), oxalic acid, calcium hydroxide, benzene, creosol, alcohol, cyclohexane, toluene, xylene, benzene, grease |

Chemicals That Do Not Affect ABS Resin or Epoxy Resin

| ABS resin | Epoxy resin |
|--|---|
| Ammonia, kerosine, mineral oil, developer, Yushiroken S50, Chemi-Cool Z, Velocity No. 3, Yushiroken EEE-30Y, petroleum, grease, acetic acid, oxalic acid, calcium hydroxide, phosphoric acid (30% RT), hydrochloric acid (10% RT), potassium hydroxide | Ammonia, hydrochloric acid (10% RT), potassium hydroxide, petroleum, gasoline, Yushiroken S50, Chemi-Cool Z, Velocity No. 3, Yushiroken EEE-30Y |

Note: The above results are from tests conducted at room temperature (23°C). Even if the chemicals do not affect the ABS or epoxy resins at room temperature, they may affect the resins at higher or lower temperatures. Check the chemicals carefully in advance.

Chemical Resistance of Tags

Applicable Models

V680-D1KP66T/MT

| Chemical | | At room temperature | At 90°C |
|----------------------------|-----|---------------------|---------|
| Hydrochloric acid | 37% | A | A |
| | 10% | A | A |
| Sulfuric acid | 98% | A | B |
| | 50% | A | A |
| | 30% | A | A |
| | 3% | A | A |
| Nitric acid | 60% | B | C |
| | 40% | A | B |
| | 10% | A | A |
| Hydrogen fluoride solution | 40% | A | A |
| Chromic acid | 40% | A | A |
| Hydrogen peroxide solution | 28% | A | B |
| | 3% | A | A |
| Sodium hydroxide solution | 60% | A | A |
| | 10% | A | A |
| | 1% | A | A |
| Ammonia solution | 28% | A | B |
| | 10% | A | B |
| Sodium chloride | 10% | A | A |
| Sodium carbonate | 20% | A | A |
| | 2% | A | A |

| Chemical | | At room temperature | At 90°C |
|----------------------------|-----|---------------------|---------|
| Sodium hypochlorite | | A | A |
| Phenol solution | 5% | A | A |
| Glacial acetic acid | | A | A |
| Acetic acid | | A | A |
| Oleic acid | | A | A |
| Methyl alcohol | 95% | A | A |
| Ethyl alcohol | 95% | A | A |
| Ethyl acetate | | A | A |
| Sebacic acid diethyl-hexyl | | A | A |
| Acetone | | A | A |
| Diethyl ether | | A | A |
| n-heptane | | A | A |
| 2-2-4 trimethylpentane | | A | A |
| Benzene | | A | A |
| Toluene | | A | A |
| Aniline | | A | A |
| Mineral oil | | A | A |
| Gasoline | | A | A |
| Insulating oil | | A | A |
| Dichloroethylene | | A | A |
| Carbon tetrachloride | | A | A |

A: Has no adverse effect, B: May cause discoloration, swelling, etc., C: Causes deformation, cracks, etc.



CHECK!

The above table shows the extent of changes in PPS resin exposed to each chemical at room temperature and at 90°C. If actual chemicals, concentrations, and temperatures are different from those shown in the tables, always conduct tests under the actual conditions in which the Tags are to be used.

Applicable Model

V680-D1KP52MT

PPS resin is used for case material and epoxy resin for filling material. Refer to the following lists and do not use chemicals that affect PPS and epoxy resin.

Chemicals That Cause Deformations, Cracks, Etc.

| PPS resin | Epoxy resin |
|------------|---|
| Aqua regia | Aqua regia, chromic acid, sulfuric acid (90% RT), nitric acid (60% RT), ammonia solution, acetone, methylene chloride, phenol |

Chemicals That May Cause Discoloration, Swelling, Etc.

| PPS resin | Epoxy resin |
|----------------------|--|
| Nitric acid (60% RT) | Sulfuric acid (10% RT), nitric acid (10% RT), hydrochloric acid (30% RT), acetic acid (50% RT), oxalic acid, calcium hydroxide, benzene, creosol, alcohol, cyclohexane, toluene, xylene, benzene, grease |

Chemicals that Do Not Affect PPS Resin or Epoxy Resin

| PPS resin | Epoxy resin |
|--|--|
| Hydrochloric acid (37%RT), sulfuric acid (98%RT), nitric acid (40%RT), Hydrogen fluoride solution (40%RT), chromic acid (40%RT), hydrogen peroxide (28%RT), sodium hydroxide solution (60%RT), ammonia solution (28%RT), sodium chloride (10%RT), sodium carbonate (20%RT), sodium hypochlorite, phenol solution (5%RT), glacial acetic acid, acetic acid, oleic acid, Methyl alcohol (95%RT), ethyl alcohol (95%RT), Ethyl acetate, sebacic acid, diethylhexyl, acetone, diethyl ether, n-heptane, 2-2-4 trimethylpentane, benzene, toluene, aniline, mineral oil, gasoline, insulating oil, dichloroethylene, carbon tetrachloride | Ammonia, hydrochloric acid (10% RT), potassium hydroxide, petroleum, gasoline, Yushiroken S50, Chemi-Cool Z, Velocity No. 3, Yushiroken EEE-30Y, methyl ethyl ketone, sodium hydroxide (10%RT) |

Note: The above results are from tests conducted at room temperature (23°C). Even if the chemicals do not affect the PPS or epoxy resins at room temperature, they may affect the resins at higher or lower temperatures. Check the chemicals carefully in advance.

MEMO

Revision History

A manual revision code appears as a suffix to the catalog number at the bottom of the front and rear pages.

Cat. No.: Z248-E1-01

↑
Revision code

| Revision code | Date | Revised contents |
|---------------|--------------|---------------------|
| 01 | October 2006 | Original production |