



RADIO TEST REPORT

Test Report No. : 28DE0079-HO-01-A

Applicant : OMRON Corporation
Type of Equipment : Radio Frequency Identification System (RFID System)
Model No. : DeviceNet ID Slave : V680-HAM42-DRT
Antenna : V680-HS65-W, V680-HS63-W,
V680-HS52-W, V680-HS51
Test regulation : FCC Part 15 Subpart C: 2008
Section 15.207 and 15.225
FCC ID : E4E6CYSIDV6800108
Test Result : Complied

1. This test report shall not be reproduced in full or partial, without the written approval of UL Japan, Inc.
2. The results in this report apply only to the sample tested.
3. This sample tested is in compliance with above regulation.
4. The test results in this report are traceable to the national or international standards.

Date of test: December 13, 2007 to February 2, 2008

Tested by:

Kazufumi Nakai
EMC Services

Shinya Watanabe
EMC Services

Approved by :

Mitsuru Fujimura
Assistant Manager of EMC Services

NVLAP LAB CODE: 200572-0

This laboratory is accredited by the NVLAP LAB CODE 200572-0, U.S.A. The tests reported herein have been performed in accordance with its terms of accreditation.
*As for the range of Accreditation in NVLAP, you may refer to the WEB address, <http://uljapan.co.jp/emc/nvlap.htm>

UL Japan, Inc.

Head Office EMC Lab.

4383-326 Asama-cho, Ise-shi, Mie-ken 516-0021 JAPAN

Telephone : +81 596 24 8116

Facsimile : +81 596 24 8124

MF060b (09.01.08)

CONTENTS	PAGE
SECTION 1: Customer information	3
SECTION 2: Equipment under test (E.U.T.)	3
SECTION 3: Test specification, procedures & results	5
SECTION 4: Operation of E.U.T. during testing	9
SECTION 5: Conducted emission	14
SECTION 6: Radiated emission (Fundamental , Spurious Emission and Spectrum Mask)..	15
SECTION 7: 20dB Bandwidth.....	16
SECTION 8: Frequency Tolerance	16
SECTION 9: 99% Occupied Bandwidth	16
APPENDIX 1: Photographs of test setup.....	17
Conducted emission	17
Radiated emission	21
Worst Case Position.....	25
APPENDIX 2: Data of EMI test	30
Conducted emission	30
Radiated emission(Fundamental emission and Spectrum Mask)	39
Radiated emission (Spurious emission : below 30MHz)	47
Radiated emission (Spurious emission: above 30MHz)	55
20dB Bandwidth.....	63
99% Occupied Bandwidth	64
Frequency Tolerance	65
APPENDIX 3: Test instruments	66

SECTION 1: Customer information

Company Name : OMRON Corporation
Brand or Trade name : OMRON
Address : 3-2, NARUTANI, NAKAYAMA-CHO, AYABE-SHI, KYOTO, 623-0105
Japan
Telephone Number : +81-773-42-6662
Facsimile Number : +81-773-42-6135
Contact Person : Toshiya Kitagawa

SECTION 2: Equipment under test (E.U.T.)

2.1 Identification of E.U.T.

Type of Equipment : Radio Frequency Identification System (RFID System)
Model No. : DeviceNet ID Slave: V680-HAM42-DRT
Antenna: V680-HS65-W, V680-HS63-W, V680-HS52-W, V680-HS51
Serial No. : V680-HAM42-DRT: 6
V680-HS65-W: D1 (2.0m), A-7 (12.5m)
V680-HS63-W: D3 (2.0m), D1 (12.5m)
V680-HS52-W: D2 (2.0m), 2 (12.5m)
V680-HS51: 10
Rating : DC 24.0V
Country of Manufacture : Japan
Receipt Date of Sample : December 8, 2007
Condition of EUT : Production prototype
(Not for Sale: This sample is equivalent to mass-produced items.)
Modification of EUT : No modification by the test lab.

2.2 Product Description

Model No: V680-HAM42-DRT / V680-HS65-W, V680-HS63-W, V680-HS52-W, V680-HS51 (referred to as EUT in this report) is DeviceNet ID Slave / Antenna (Radio Frequency Identification System (RFID System)).
The clock frequency of EUT is 16MHz (CPU) and 13.56MHz (Radio).

Equipment Type : Transceiver
Frequency band : 13.553 to 13.567 MHz
Frequency of Operation : 13.56 MHz
Type of modulation : ASK
Power control : N/A
Mode of operation : Simplex
Antenna Type : Loop Antenna
Method of Frequency Generation : Crystal
Operating voltage : DC 6.0V and 5.0V

UL Japan, Inc.

Head Office EMC Lab.

4383-326 Asama-cho, Ise-shi, Mie-ken 516-0021 JAPAN

Telephone : +81 596 24 8116

Facsimile : +81 596 24 8124

Variant models:

	Model	Differences
Antenna (HS6 series)	V680-HS65-W, V680-HS63-W (tested model)	Standard cable (watertight connector)
	V680-HS65-R, V680-HS63-R	Flexible cable (Non-watertight connector)
Antenna (HS5 series)	V680-HS52-W (tested model)	Standard cable (watertight connector)
	V680-HS52-R	Flexible cable (Non-watertight connector)

SECTION 3: Test specification, procedures & results

3.1 Test Specification

Test Specification : FCC Part15 Subpart C 2008, final revised on January 30, 2008

Title : FCC 47CFR Part15 Radio Frequency Device Subpart C Intentional Radiators
Section 15.207 Conducted limits
Section 15.225 Operation within the band 13.110-14.010MHz

*The revision on January 30, 2008 does not influence the test specification applied to the EUT.

FCC 15.31 (e)

This EUT provides stable voltage(DC6.0V and 5.0V) constantly to RF Module regardless of input voltage. Therefore, this EUT complies with the requirement.

FCC Part 15.203 Antenna requirement

The EUT has an external and particular antenna connector, but it is installed by the professionals. Therefore, the equipment complies with the antenna requirement of Section 15.203.

UL Japan, Inc.

Head Office EMC Lab.

4383-326 Asama-cho, Ise-shi, Mie-ken 516-0021 JAPAN

Telephone : +81 596 24 8116

Facsimile : +81 596 24 8124

3.2 Procedures and results

No.	Item	Test Procedure	Specification	Remarks	Deviation	Worst margin	Results
1	Conducted emission	<FCC> ANSI C63.4:2003 7. AC powerline conducted emission measurements <IC> RSS-Gen 7.2.2	<FCC> Section 15.207 <IC> RSS-Gen 7.2.2	-	N/A	[AV] 5.4dB 27.12024MHz, N 27.11968MHz, L [QP] 7.5dB 0.39092MHz, L	Complied
2	Electric Field Strength of Fundamental Emission	<FCC> ANSI C63.4:2003 13. Measurement of intentional radiators <IC> RSS-Gen 4.8, 4.11	<FCC> Section 15.225(a) <IC> RSS-210 A2.6	Radiated	N/A	47.3dB, 13.56000MHz, QP, 0deg.	Complied
3	Spectrum Mask	<FCC> ANSI C63.4:2003 13. Measurement of intentional radiators <IC> RSS-Gen 4.9, 4.11	<FCC> Section 15.225(b)(c) <IC> RSS-210 A2.6	Radiated	N/A	28.7dB, 13.55300MHz, QP, 0deg.	Complied
4	20dB Bandwidth	<FCC> ANSI C63.4:2003 13. Measurement of intentional radiators <IC> -	<FCC> Section15.215(c) <IC> -	Radiated	N/A	See data	Complied
5	Electric Field Strength of Spurious Emission	<FCC> ANSI C63.4:2003 13. Measurement of intentional radiators <IC> RSS-Gen 4.9, 4.11	<FCC> Section15.209, Section 15.225 (d) <IC> RSS-210 A2.6	Radiated	N/A	7.0dB 431.602MHz, Horizontal, QP	Complied
6	Frequency Tolerance	<FCC> ANSI C63.4:2003 13. Measurement of intentional radiators <IC> RSS-Gen 4.7	<FCC> Section15.225(e) <IC> RSS-210 A2.6	Radiated	N/A	See data	Complied

Note: UL Japan, Inc.'s EMI Work Procedures No.QPM05 and QPM15

*These tests were performed without any deviations from test procedure except for additions or exclusions.

3.3 Addition to standards

No.	Item	Test Procedure	Specification	Remarks	Deviation	Worst margin	Results
1	99% Occupied Band Width	<IC> RSS-Gen 4.6.1	<IC> RSS-Gen 4.6.1	Radiated	N/A	N/A	Complied

UL Japan, Inc.

Head Office EMC Lab.

4383-326 Asama-cho, Ise-shi, Mie-ken 516-0021 JAPAN

Telephone : +81 596 24 8116

Facsimile : +81 596 24 8124

3.4 Uncertainty

The following uncertainties have been calculated to provide a confidence level of 95% using a coverage factor k=2.

Test room	Conducted emission	Radiated emission (10m*)			Radiated emission (3m*)			Radiated emission (3m*)	
	150kHz-30MHz	9kHz-30MHz	30MHz-300MHz	300MHz-1GHz	9kHz-30MHz	30MHz-300MHz	300MHz-1GHz	1GHz-18GHz	18GHz-40GHz
No.1 semi-anechoic Chamber (±)	3.7dB	3.1dB	4.7dB	4.4dB	3.2dB	3.7dB	4.4dB	5.9dB	6.1dB
No.2 semi-anechoic chamber (±)	3.7dB	-	-	-	3.2dB	4.3dB	3.9dB	5.9dB	6.1dB
No.3 semi-anechoic chamber (±)	3.7dB	-	-	-	3.2dB	4.2dB	4.4dB	5.9dB	6.1dB
No.4 semi-anechoic chamber (±)	3.7dB	-	-	-	3.2dB	4.2dB	4.4dB	5.9dB	6.1dB

*10m/3m = Measurement distance

Conducted emission test

The data listed in this test report has enough margin, more than the site margin.

Radiated emission test(3m)

The data listed in this test report has enough margin, more than the site margin.

Other test except Conducted Emission and Spurious Emission (Radiated)

The measurement uncertainty for this test is 3.0dB.

The data listed in this test report has enough margin, more than the site margin.

UL Japan, Inc.

Head Office EMC Lab.

4383-326 Asama-cho, Ise-shi, Mie-ken 516-0021 JAPAN

Telephone : +81 596 24 8116

Facsimile : +81 596 24 8124

3.5 Test Location

UL Japan, Inc. Head Office EMC Lab. *NVLAP Lab. code: 200572-0
4383-326 Asama-cho, Ise-shi, Mie-ken 516-0021 JAPAN
Telephone : +81 596 24 8116 Facsimile : +81 596 24 8124

	FCC Registration Number	IC Registration Number	Width x Depth x Height (m)	Size of reference ground plane (m) / horizontal conducting plane	Other rooms
No.1 semi-anechoic chamber	313583	IC4247	19.2 x 11.2 x 7.7m	7.0 x 6.0m	No.1 Power source room
No.2 semi-anechoic chamber	655103	IC4247-2	7.5 x 5.8 x 5.2m	4.0 x 4.0m	-
No.3 semi-anechoic chamber	148738	IC4247-3	12.0 x 8.5 x 5.9m	6.8 x 5.75m	No.3 Preparation room
No.3 shielded room	-	-	4.0 x 6.0 x 2.7m	N/A	-
No.4 semi-anechoic chamber	134570	IC4247-4	12.0 x 8.5 x 5.9m	6.8 x 5.75m	No.4 Preparation room
No.4 shielded room	-	-	4.0 x 6.0 x 2.7m	N/A	-
No.5 semi-anechoic chamber	-	-	6.0 x 6.0 x 3.9m	6.0 x 6.0m	-
No.6 shielded room	-	-	4.0 x 4.5 x 2.7m	4.75 x 5.4 m	-
No.6 measurement room	-	-	4.75 x 5.4 x 3.0m	4.75 x 4.15 m	-
No.7 shielded room	-	-	4.7 x 7.5 x 2.7m	4.7 x 7.5m	-
No.8 measurement room	-	-	3.1 x 5.0 x 2.7m	N/A	-
No.9 measurement room	-	-	8.0 x 4.5 x 2.8m	N/A	-
No.10 measurement room	-	-	2.6 x 2.8 x 2.5m	2.4 x 2.4m	-
No.11 measurement room	-	-	3.1 x 3.4 x 3.0m	2.4 x 3.4m	-

* Size of vertical conducting plane (for Conducted Emission test) : 2.0 x 2.0m for No.1, No.2, No.3, and No.4 semi-anechoic chambers and No.3 and No.4 shielded rooms.

3.6 Test set up, Test instruments and Data of EMI

Refer to APPENDIX 1 to 3.

SECTION 4: Operation of E.U.T. during testing

4.1 Operating Modes

The EUT was operated in a manner similar to typical use during the tests.

The mode is used :

1. Transmitting 13.56MHz With Tag and Communication with the peripherals*1)
2. Transmitting 13.56MHz Without Tag and Communication with the peripherals*1)
3. Transmitting 13.56MHz With Tag*2)
4. Transmitting 13.56MHz Without Tag*2)

*1): for Conducted emission

*2): other tests except Conducted emission

*EUT transmits and receives the data from tag simultaneously.

Justification: The system was configured in typical fashion (as a customer would normally use it) for testing.

Frequency Tolerance:

Temperature for the extreme tests : -30 deg.C.(minimum) to + 50deg.C.(maximum)

Voltage for the extreme tests : Vnom: DC 24.0V, Vmin: 20.4V, Vmax: 27.6V

*Voltage extreme tests were performed, although this EUT provides stable voltage (DC6.0V and 5.0V) constantly to RF Module regardless of input voltage.

UL Japan, Inc.

Head Office EMC Lab.

4383-326 Asama-cho, Ise-shi, Mie-ken 516-0021 JAPAN

Telephone : +81 596 24 8116

Facsimile : +81 596 24 8124

4.2 Configuration and peripherals

[Conducted Emission]

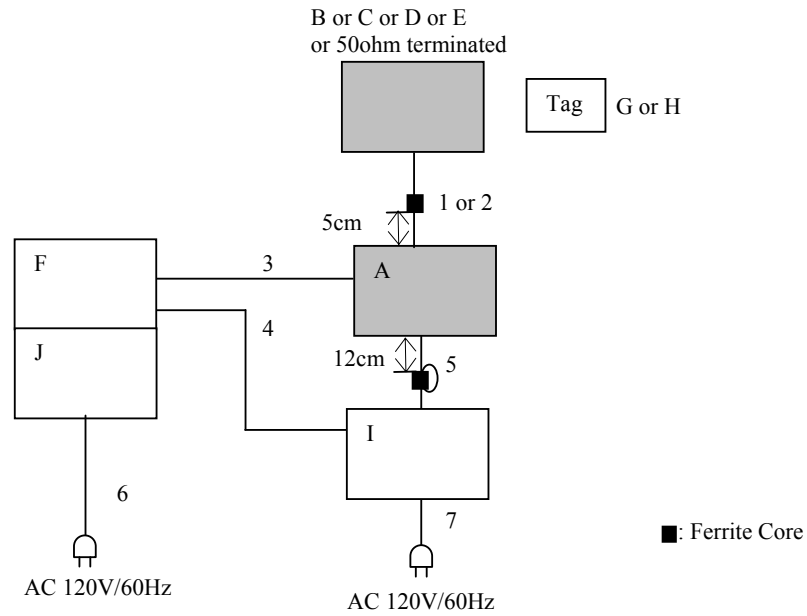

- * Cabling and setup were taken into consideration and test data was taken under worse case conditions.
- * For length and material (between -W and -R) of Antenna Cable, the worse case at each test was used.

Description of EUT and Support equipment

No.	Item	Model number	Serial number	Manufacturer	Remark
A	DeviceNet ID Slave	V680-HAM42-DRT	6	OMRON	EUT
B	Antenna	V680-HS65-W	D1(2.0m) or A-7(12.5m)	OMRON	EUT
C	Antenna	V680-HS63-W	D3(2.0m) or D1(12.5m)	OMRON	EUT
D	Antenna	V680-HS52-W	D2(2.0m) or 2(12.5m)	OMRON	EUT
E	Antenna	V680-HS51	10	OMRON	EUT
F	PLC	CJ1 Series	D2	OMRON	-
G	Tag	V680-D2KF67	2	OMRON	for V680-HS65-W and V680-HS63-W
H	Tag	V680-D2K52M	31	OMRON	for V680-HS52-W and V680-HS51
I	Power Supply Unit	S8VS-03024	-	OMRON	-
J	Power Supply Unit	CJ1W-PA205R	-	OMRON	-

List of cables used

No.	Name	Length (m)	Shield		Remark
			Cable	Connector	
1	Antenna Cable	2.0m	Shielded	Shielded	for V680-HS51 One Ferrite Core (model:ZCAT1525-0430, made by TDK, 1 turn) for V680-HS65-W, V680-HS63-W, V680-HS52-W One Ferrite Core (model:ZCAT1730-0730, made by TDK, 1 turn)
2	Antenna Cable	12.5m	Shielded	Shielded	for V680-HS65-W, V680-HS63-W, V680-HS52-W One Ferrite Core (model:ZCAT1730-0730, made by TDK, 1 turn)
3	DeviceNet Cable	2.0m	Unshielded	Unshielded	-
4	DC Supply Cable	0.1m	Unshielded	Unshielded	-
5	DC Supply Cable	0.8m	Unshielded	Unshielded	One Ferrite Core (model:ZCAT2032-0930, made by TDK, 2 turns)
6	AC Supply Cable	1.8m	Unshielded	Unshielded	-
7	AC Supply Cable	1.8m	Unshielded	Unshielded	-

UL Japan, Inc.

Head Office EMC Lab.

4383-326 Asama-cho, Ise-shi, Mie-ken 516-0021 JAPAN

Telephone : +81 596 24 8116

Facsimile : +81 596 24 8124

[Other tests except Conducted Emission]

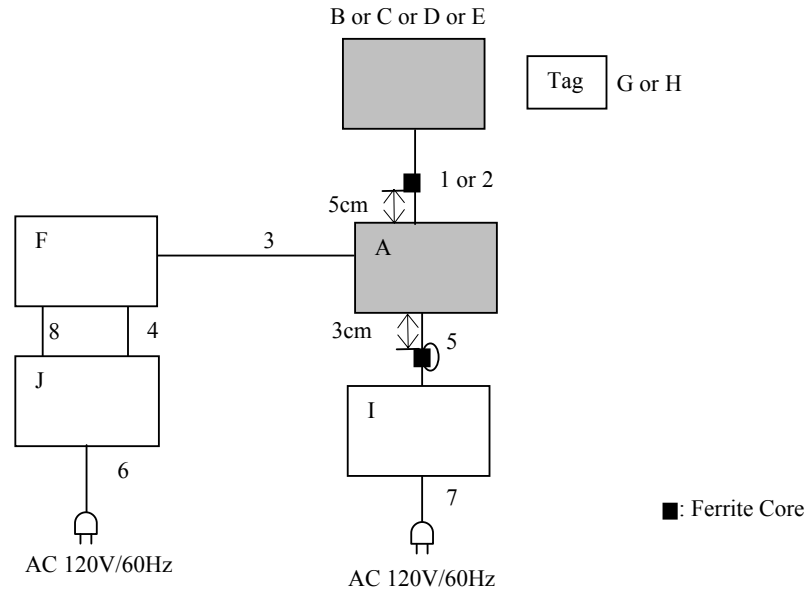

- * Cabling and setup were taken into consideration and test data was taken under worse case conditions.
- * For length and material (between -W and -R) of Antenna Cable, the worse case at each test was used.

Description of EUT and Support equipment

No.	Item	Model number	Serial number	Manufacturer	Remark
A	DeviceNet ID Slave	V680-HAM42-DRT	6	OMRON	EUT
B	Antenna	V680-HS65-W	D1(2.0m) or A-7(12.5m)	OMRON	EUT
C	Antenna	V680-HS63-W	D3(2.0m) or D1(12.5m)	OMRON	EUT
D	Antenna	V680-HS52-W	D2(2.0m) or 2(12.5m)	OMRON	EUT
E	Antenna	V680-HS51	10	OMRON	EUT
F	PLC	CJ1 Series	D2	OMRON	-
G	Tag	V680-D2KF67	2	OMRON	for V680-HS65-W and V680-HS63-W
H	Tag	V680-D2K52M	31	OMRON	for V680-HS52-W and V680-HS51
I	Power Supply Unit	S8VS-03024	-	OMRON	-
I	Power Supply Unit	S8VS-03024	-	OMRON	-

List of cables used

No.	Name	Length (m)	Shield		Remark
			Cable	Connector	
1	Antenna Cable	2.0m	Shielded	Shielded	for V680-HS51 One Ferrite Core (model:ZCAT1525-0430, made by TDK, 1 turn) for V680-HS65-W, V680-HS63-W, V680-HS52-W One Ferrite Core (model:ZCAT1730-0730, made by TDK, 1 turn)
2	Antenna Cable	12.5m	Shielded	Shielded	for V680-HS65-W, V680-HS63-W, V680-HS52-W One Ferrite Core (model:ZCAT1730-0730, made by TDK, 1 turn)
3	DeviceNet Cable	2.0m	Unshielded	Unshielded	-
4	DC Supply Cable	0.3m	Unshielded	Unshielded	-
5	DC Supply Cable	0.8m	Unshielded	Unshielded	One Ferrite Core (model:ZCAT2032-0930, made by TDK, 2 turns)
6	AC Supply Cable	1.8m	Unshielded	Unshielded	-
7	AC Supply Cable	1.8m	Unshielded	Unshielded	-
8	AC Supply Cable	0.2m	Unshielded	Unshielded	-

UL Japan, Inc.

Head Office EMC Lab.

4383-326 Asama-cho, Ise-shi, Mie-ken 516-0021 JAPAN

Telephone : +81 596 24 8116

Facsimile : +81 596 24 8124

SECTION 5: Conducted emission

5.1 Operating environment

Test place : No.2 semi anechoic chamber.
Temperature : See data
Humidity : See data

5.2 Test configuration

EUT was placed on a urethane platform of nominal size, 0.5m by 1.0m, raised 80cm above the conducting ground plane. The rear of tabletop was located 40cm to the vertical conducting plane. The rear of EUT and its peripherals was aligned and flushed with rear of tabletop. All other surfaces of tabletop were at least 80cm from any other grounded conducting surface. EUT was located 80cm from LISN/AMN and excess AC cable was bundled in center. I/O cables that were connected to the peripherals were bundled in center. They were folded back and forth forming a bundle 30cm to 40cm long and were hanged at a 40cm height to the ground plane. Each EUT current-carrying power lead, except the ground (safety) lead, was individually connected through a LISN/ an AMN to the input power source. All unused 50ohm connectors of the LISN/ AMN were resistively terminated in 50ohm when not connected to the measuring equipment. The AC Mains Terminal Continuous disturbance Voltage has been measured with the EUT on a horizontal conducting plane 4.0 x 4.0m and a vertical conducting plane 2.0 x 2.0m in a semi anechoic chamber. A drawing of the set up is shown in the photos of APPENDIX 1.

5.3 Test conditions

Frequency range : 0.15MHz – 30MHz
EUT position : Table top
EUT operation mode : See Clause 4.1

5.4 Test procedure

The AC Mains Terminal Continuous disturbance Voltage had been measured with the EUT in the semi anechoic chamber. The EUT was connected to a Line Impedance Stabilization Network (LISN)/ Artificial Mains Network (AMN). An overview sweep with peak detection has been performed. The measurements had been performed with a quasi-peak detector and if required, with an average detector. The conducted emission measurements were made with the following detector function of the test receiver.
Detector Type : QP and AV
IF Bandwidth : 9kHz

5.5 Test result

Summary of the test results : Pass

SECTION 6: Radiated emission (Fundamental , Spurious Emission and Spectrum Mask)

6.1 Operating environment

The test was carried out in a No.3 semi anechoic chamber

Temperature : See data
Humidity : See data

6.2 Test Procedure

The Radiated Electric Field Strength intensity has been measured in a semi anechoic chamber with a ground plane and at a distance of 3m.

Frequency : From 9kHz to 30MHz at distance 3m, Used antenna: Loop
The EUT was rotated a full revolution in order to obtain the maximum value of the electric field intensity.
The measurements were performed for each antenna angle 0deg. , 45deg. and 90deg.

Frequency : From 30MHz to 1GHz at distance 3m, Used antenna: Biconical (30-300MHz), Logperiodic (300-1000MHz)
The measuring antenna height was varied between 1 and 4m and EUT was rotated a full revolution in order to obtain the maximum value of the electric field intensity.
The measurements were performed for both vertical and horizontal antenna polarization.

Measurements were performed with a QP, PK, and AV detector.
The radiated emission measurements were made with the following detector function of the test receiver.

	From 9kHz to 90kHz and From 110kHz to 150kHz	From 90kHz to 110kHz	From 150kHz to 490kHz	From 490kHz to 30MHz	From 30MHz to 1GHz
Detector Type	PK/AV	QP	PK/AV	QP	QP
IF Bandwidth	200Hz	200Hz	9kHz	9kHz	120kHz

- The carrier level and noise levels were confirmed at each position of X, Y and Z axes of EUT to see the position of maximum noise, and the test was made at the position that has the maximum noise.

* FCC Part 15 Section 15.31 (f)(2) / IC RSS-Gen 4.11 (9kHz-30MHz)
9kHz – 490kHz [Limit at 3m]=[Limit at 300m]-40log (3[m]/300[m])
490kHz – 30MHz[Limit at 3m]=[Limit at 30m]-40log (3[m]/30[m])

6.3 Test result

Summary of the test results : Pass

SECTION 7: 20dB Bandwidth

Test Procedure

The measurement was performed under the condition which has the maximum Electric field strength.

Test data : APPENDIX 2
Test result : Pass

SECTION 8: Frequency Tolerance

Test Procedure

The measurement was performed with Electric field strength using a spectrum analyzer.

Test data : APPENDIX 2
Test result : Pass

SECTION 9: 99% Occupied Bandwidth

Test Procedure

The measurement was performed under the condition which has the maximum Electric field strength.

Test data : APPENDIX 2
Test result : Pass