







High-speed, Long Life, Batteryless RFID System

- High-speed communications requiring only 14 ms to read or write 128 bytes of data.
- Long-life battery-free tags to read and write data 1,000 million times.
- Versatile functions, such as auto repeat, repeat input trigger, and tag specification.
- Self-execution mode for data processing with no host controller intervention.

Note: The use of the V690 in may be subject to radio regulations and EMC restrictions in individual countries. Contact your OMRON representative for details.



Ordering Information

Product	Model	Shape/Specification		
ID Tag	V670-D13F03		40 × 40 × 4.5 mm	128 bytes
Antenna	V670-H11		40 × 53 × 23 mm	2-m cable
Controller	V670-CD1D		90 × 66 × 75 mm	RS-232C interface operating at 24 VDC with a single antenna connector
Antenna Extension Cables	V670-A40		3 m	Material: Polyvinyl chloride Connectors are not watertight.
	V670-A41		10 m	
	V670-A42		18 m	
	V670-A43		28 m	
Programming Console	C200H-PRO27-E			Operation monitor, set value display, communications, test communications, and error log functions.
Programming Console Conversion Cable	V700-P10		2 m	Connects the V670-CD1D and C200H-PRO27.

System Configuration

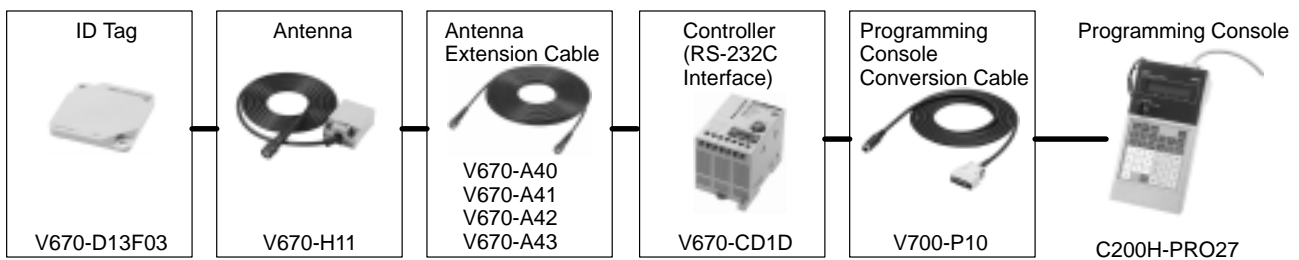

Note: When extending the antenna cable, do not use any cable other than the Antenna Extension Cables from OMRON.

Specifications

■ Ratings

V670-CD1D Controller

Item	Specifications
Host interface specifications	RS-232C
Number of connectable antennas	1
Power supply voltage	24 VDC \pm 10 %
Power consumption	7 W max.
Ambient temperature	Operating: 0 to 55°C (with no icing)
Ambient humidity	Operating: 35% to 85% (with no condensation)
Ambient temperature	Storage: -20 to 75°C (with no icing)
Ambient humidity	Storage: 35% to 85% (with no condensation)
Insulation resistance	20 M Ω min. (at 1,000 VDC) <ol style="list-style-type: none"> 1. Between the ground and both power supply terminals 2. Between both power supply terminals and both output terminals 3. Between both power supply terminals and casing 4. Between both output terminals and ground 5. Between both output terminals and casing 6. Between the ground terminal and casing
Dielectric strength	1,000 VAC for 1 minute in all the above combinations with a maximum leakage current of 5 mA
Protection	Panel-mounting
Vibration resistance	10 to 150 Hz, 0.2-mm double amplitude at 15 m/s ² in X, Y, and Z directions 10 times for 8 minutes each.
Shock resistance	150 m/s ² in X, Y, and Z directions 3 times each (18 times in total)
Ground	Ground at a resistance of less than 100 Ω
Material	PC/ASA resin
Weight	Approx. 270 g

V670-D13F03 ID Tags

Item	Specifications
Memory capacity	128 bytes
Memory type	FeRAM
Memory life	Number of accesses: 1,000 million times (See note.)
Data storage time	10 years (after the data is written or read)
Ambient temperature	Operating: -10 to 70°C
Ambient temperature	Storage: -10 to 70°C
Ambient humidity	Operating: 35% to 85%
Degree of protection	IEC60529 IP67
Vibration resistance	Destruction: 10 to 2,000 Hz, 1.5-mm double amplitude at 150 m/s ² in X, Y, and Z directions 10 times for 15 minutes each
Shock resistance	Destruction: 500 m/s ² in X, Y, and Z directions 3 times each (18 times in total)
Material	Filled with ABS/Epoxy resin
Weight	Approx. 6 g

Note: The number of accesses is the total number of read or write communications.



V670-H11 Antenna

Item	Specification
Communications frequency	13.56 MHz
Ambient temperature	Operating: -10 to 70°C
Ambient humidity	Operating: 35% to 85%
Ambient temperature	Storage: -25 to 85°C
Ambient humidity	35% to 85%
Insulation resistance	20 M Ω min. (at 1,000 VDC) between the terminals and casing
Dielectric strength	1,000 VAC for 1 minute between the terminals and casing with a current leakage of 1 mA
Degree of protection	IEC60529 IP67
Vibration resistance	10 to 150 Hz, 0.7-mm double amplitude at 50 m/s ² in X, Y, and Z directions 10 times for 8 minutes each
Shock resistance	150 m/s ² in X, Y, and Z directions 3 times each (18 times in total)
Material	Filled with ABS/Epoxy resin
Cable length	2 m
Weight	Approx. 160 g

Note: The connector is not watertight.

Engineering Data

■ Communications Distance

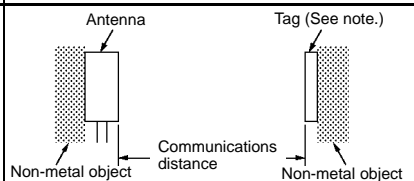
Antenna/Controller	ID Tag	Communications distance	Measurement conditions
V670-H11+V670-CD1D 	V670-D13F03 	<ul style="list-style-type: none"> Communications distance: 5 to 23 mm Communications range width: 20 mm min. (at a Tag-to-Antenna distance of 20 mm) 	

Note: If the background object of the tag is metal, no communications will be possible. For details, refer to the *V670 Operation Manual*.

■ Communications Range Chart (Typical)

Communications Range Characteristics

Combination of V670-H11 and V670-D13F03

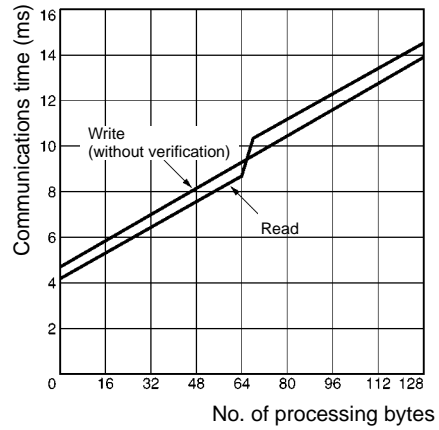
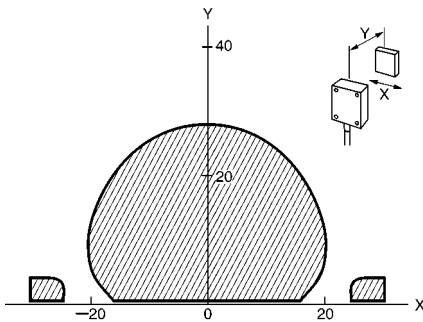

Communications Time (Reference)

Communications time is a period required for communications between the antenna and ID Tag.

Operation	No. of bytes	Calculation formula
Read	1 to 64 bytes	$T=0.07 \times N+4.22$
	65 to 128 bytes	$T=0.07 \times N+5.64$
Write	1 to 128 bytes	$T=0.07 \times N+4.72$

N: Number of bytes
T: Communications time (ms)

Movement Speed (Reference)

Tag movement speed must be a maximum of 50% of the maximum movement speed according to the number of processing bytes to ensure the reliability of communications. Conduct proper on-site tests to determine the tag movement speed.

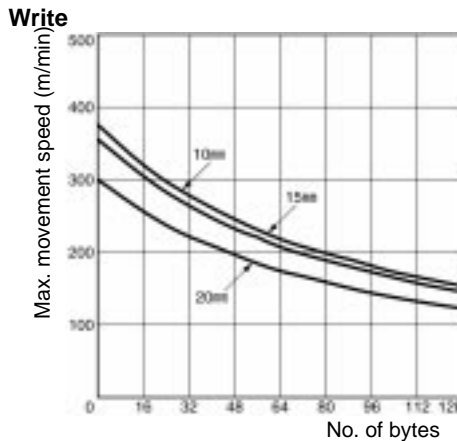
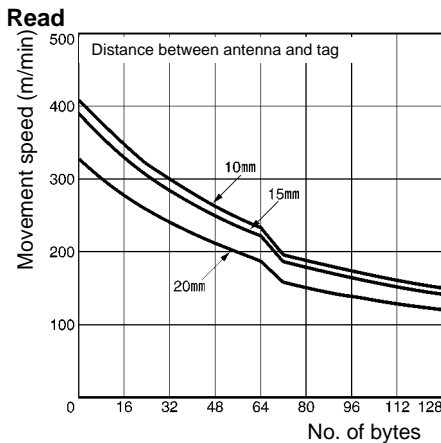

Dimensions

Note: All units are in millimeters unless otherwise indicated.

V670-D13F03 ID Tag

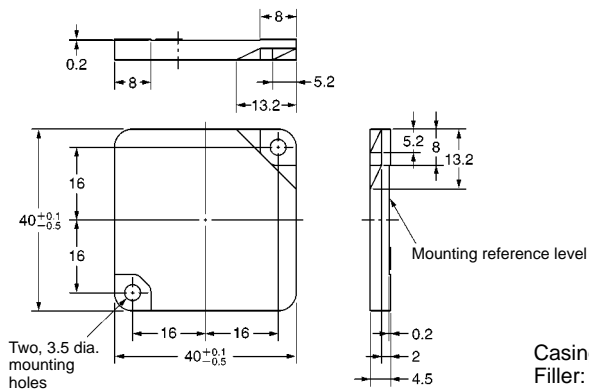

Mounting Dimensions

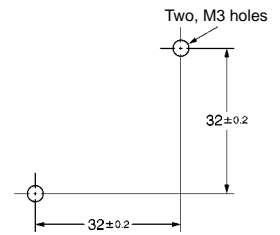

Casing material: ABS resin
Filler: Epoxy resin

V670-H11 Antenna

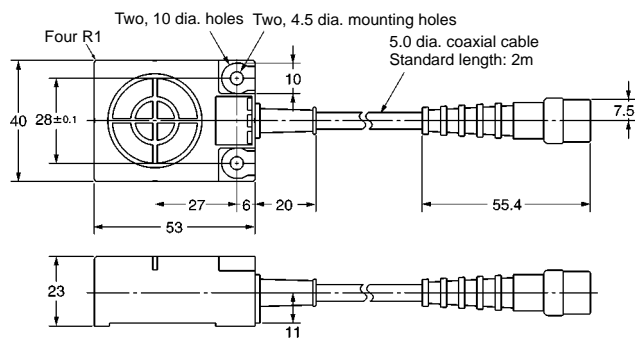

Mounting Dimensions

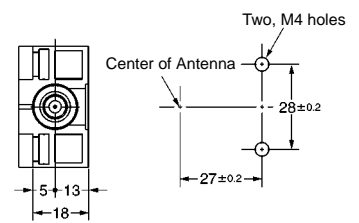

Casing material: ABS resin
Filler: Epoxy resin
Cable: PVC

V670-CD1D Controller

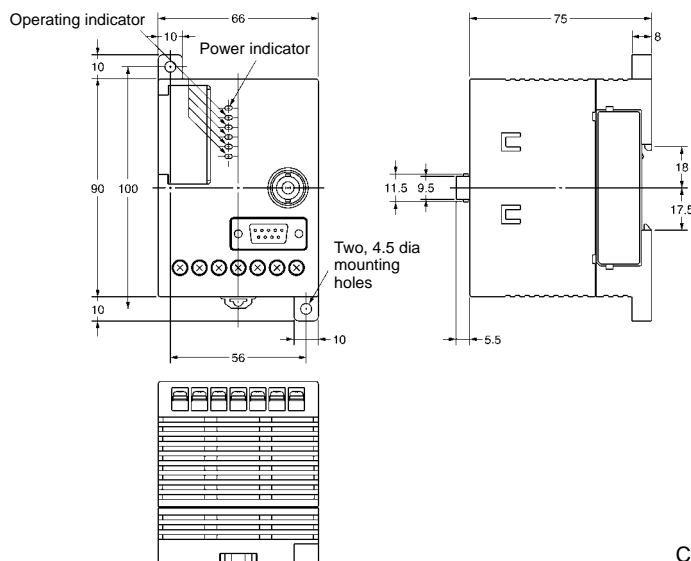

Mounting dimensions

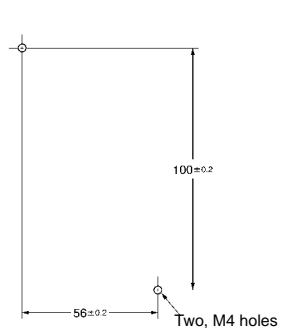

Casing material: PC/ASA resin

V670-A40/A41/A42/A43 Extension Cable

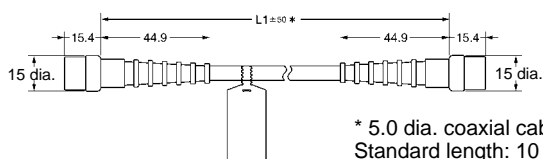

Model	Length
V670-A40	3 m
V670-A41	10 m
V670-A42	18 m
V670-A43	28 m

ALL DIMENSIONS SHOWN ARE IN MILLIMETERS.

To convert millimeters into inches, multiply by 0.03937. To convert grams into ounces, multiply by 0.03527.

Cat. No. NTLP

In the interest of product improvement, specifications are subject to change without notice.

OMRON Corporation

Industrial Automation Company

Advanced Sensors Group
Sensing Devices and Components Division H.Q.
Shiokoji Horikawa, Shimogyo-ku,
Kyoto, 600-8530 Japan
Tel: (81)75-344-7069/Fax: (81)75-344-7107

Printed in Japan
1100-1M (1100) (A)